

ULINE H-8456, H-8457
H-8458

1-800-295-5510
uline.com

STAINLESS STEEL OVERSHELF

TOOLS NEEDED



5/32" Allen Wrench
(included)

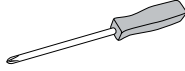

Phillips
Screwdriver



8 mm Wrench



Cobalt Drill Bit
(included)

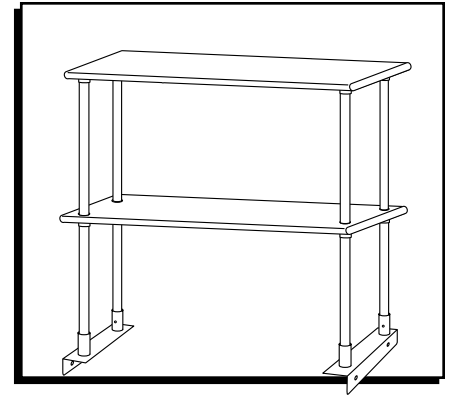

PARTS

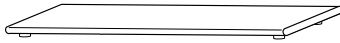

Top Shelf x 1

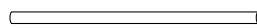

Shelf Leg x 4



M5 Flange Nut x 4



Set Screw x 12



Phillips Head
Sheet Metal
Screw x 4

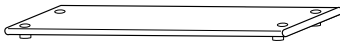

Center Shelf x 1

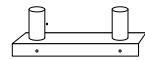

Shelf Bracket x 2



M5 x 10 mm Phillips Head
Bolt x 4



Plastic Cover x 4

ASSEMBLY

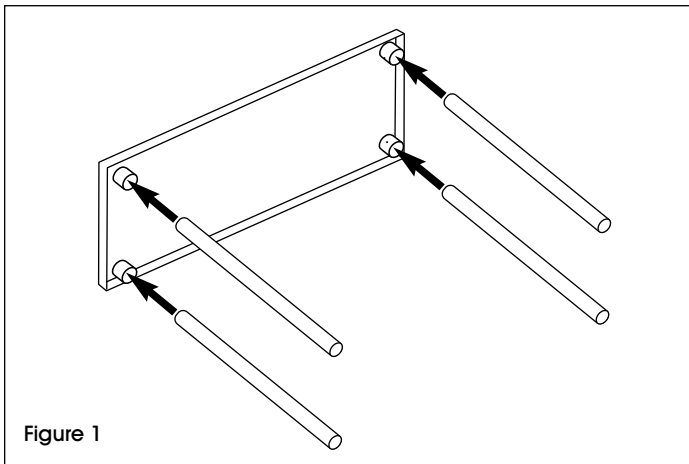

Figure 1

1. With center shelf on its side, push legs through the shelf collars to desired height. To ensure exact height, mark desired height on each leg with magic marker or grease pencil. (See Figure 1)



NOTE: Each leg must be at the same height or shelf collars could fail.

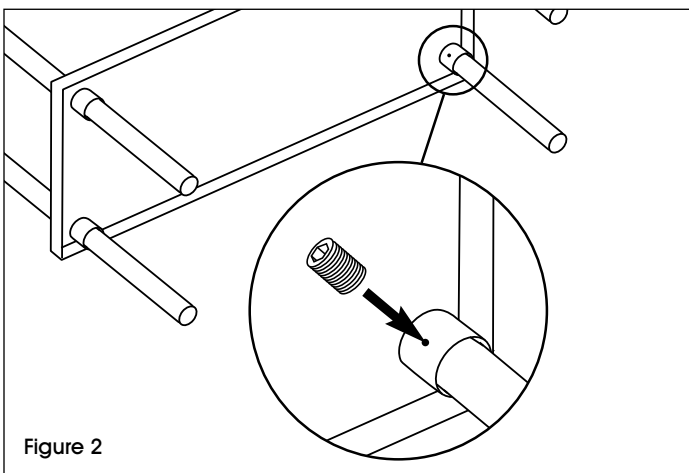
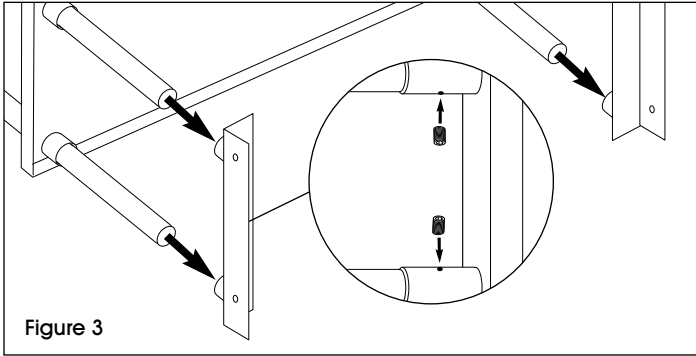



Figure 2

2. Secure legs to center shelf with set screws using 5/32" Allen wrench. (See Figure 2)

ASSEMBLY CONTINUED



3. Place bottom of legs into shelf bracket collars. Secure legs to shelf brackets with set screws using 5/32" Allen wrench. (See Figure 3)

 **NOTE:** Opening of shelf collars should face the inside of assembly.

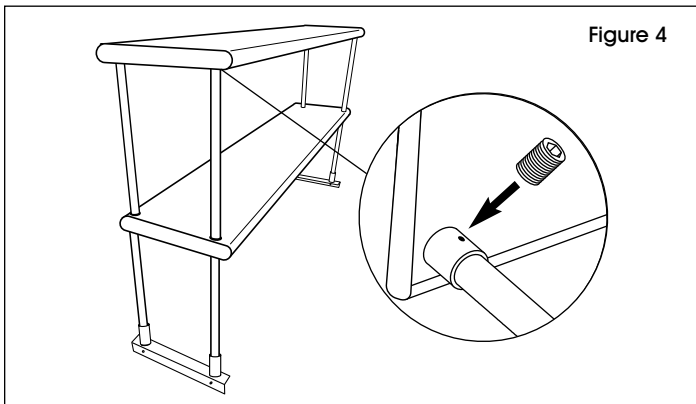

4. Stand assembly upright onto shelf bracket collars. Place top shelf onto assembly by lining up top shelf collars with top of legs and sliding into place. Secure legs to top shelf with set screws using 5/32" Allen wrench. (See Figure 4)

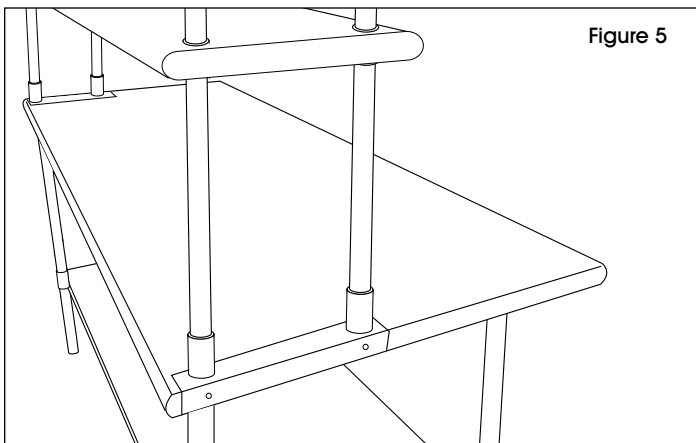

5. Place overshef assembly on top of worktable by lining up shelf brackets with the edge of the table at each end. Make sure both sides are positioned in the same area of the table top. (See Figure 5)

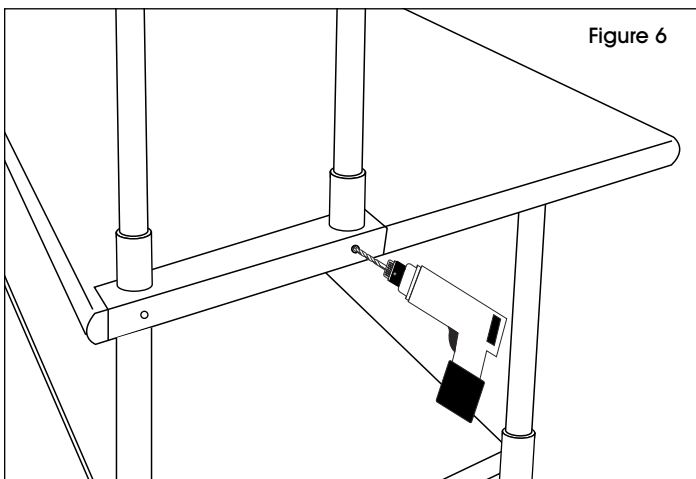

6. Mounting collars have two holes on the sides for securing to table top. Using collar holes as a template, drill through the side of the table top with supplied Cobalt drill bit. (See Figure 6)

 **NOTE:** It may take a few seconds for the drill bit to work its way through the stainless material.

ASSEMBLY CONTINUED

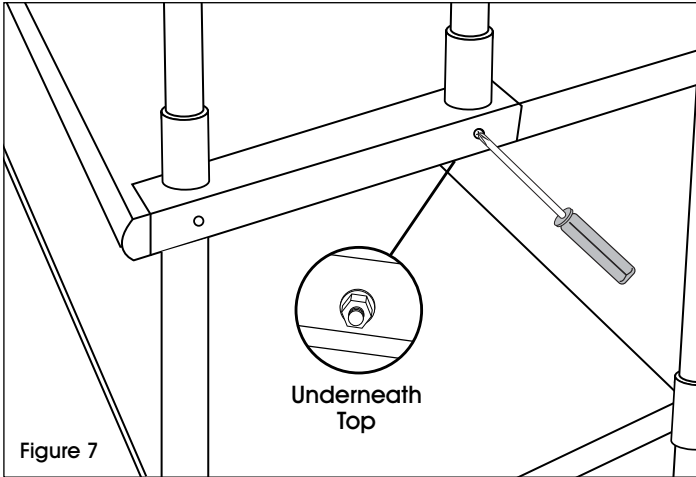

7. If the drilled holes are accessible underneath the table top, then secure this part of the shelf bracket to table top with a M5 x 10 mm Phillips head bolt and M5 flange nut using a Phillips screwdriver and 8 mm wrench. (See Figure 7)



NOTE: If holes are not accessible, secure with a sheet metal screw using a Phillips screwdriver. Flange nut will not be needed.



H-8456, H-8457
H-8458

REPISAS DE ACERO INOXIDABLE PARA MESAS DE TRABAJO

800-295-5510
uline.mx

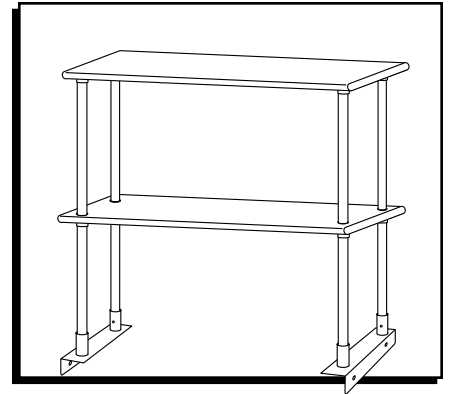

HERRAMIENTAS NECESARIAS



Llave Allen de 5/32"
(incluida)

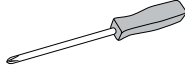

Desarmador
de Cruz



Llave de 8 mm



Broca de Cobalto
(incluida)

PARTES

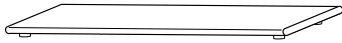

1 Repisa Superior

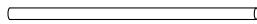

4 Patas de Repisa



4 Tuercas con
Reborde M5



12 Tornillos
de Ajuste



4 Tornillos de
Cruz para
Lámina de Metal

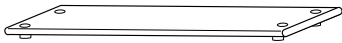

1 Repisa Central

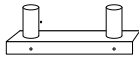

2 Soportes de Repisa



4 Pernos de Cruz
M5 x 10 mm



4 Cubiertas
de Plástico

ENSAMBLE

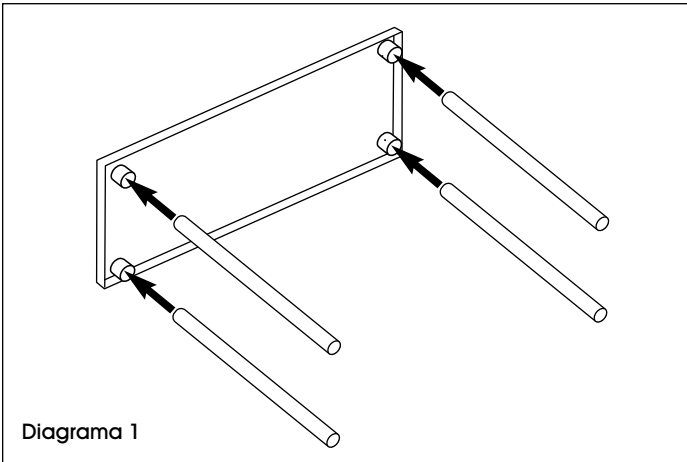

1. Con la repisa inferior de lado, empuje las patas por las ranuras de las repisas a la altura deseada. Para garantizar la altura exacta, marque la altura deseada en cada pata con un marcador de agua o lápiz litográfico. (Vea Diagrama 1)



NOTA: Cada pata debe estar a la misma altura o las ranuras de las repisas pueden desnivelarse.

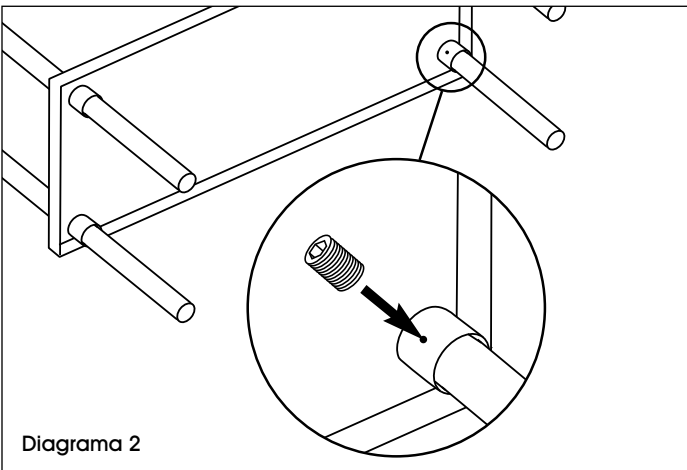

2. Asegure las patas a la repisa central con los tornillos de ajuste utilizando una llave Allen de 5/32". (Vea Diagrama 2)

CONTINUACIÓN DE ENSAMBLE

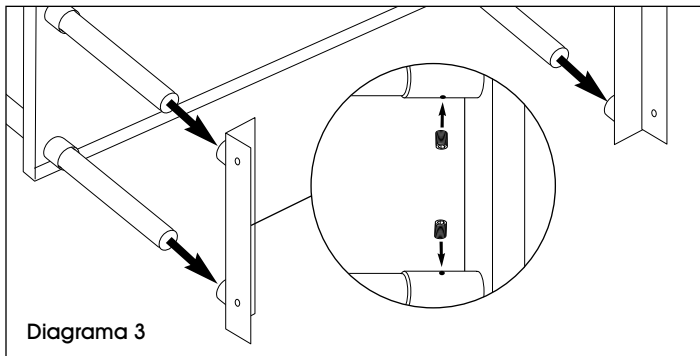

3. Coloque la parte inferior de las patas en las ranuras de los soportes de repisa. Asegure las patas a los soportes de repisa con la llave Allen de 5/32". (Vea Diagrama 3)

 **NOTA:** La abertura de las ranuras de las repisas debe de estar volteada hacia la parte interna del ensamblaje.

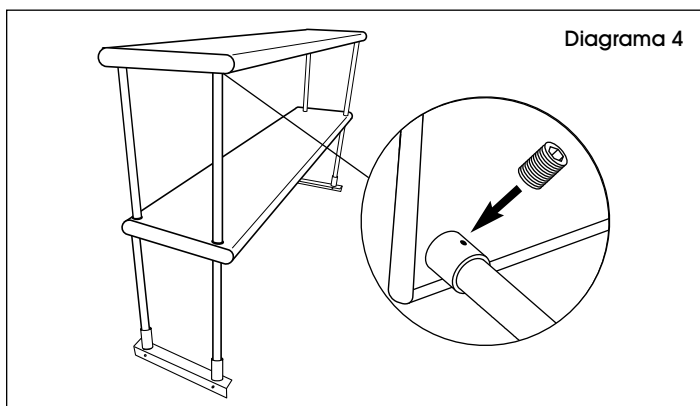

4. Coloque el ensamblaje en posición vertical sobre las ranuras de los soportes de repisa. Coloque la repisa superior sobre el ensamblaje alineando las ranuras de la repisa superior con la parte superior de las patas y deslizándola en su lugar. Asegure las patas a la repisa superior con los tornillos de ajuste utilizando la llave Allen de 5/32". (Vea Diagrama 4)

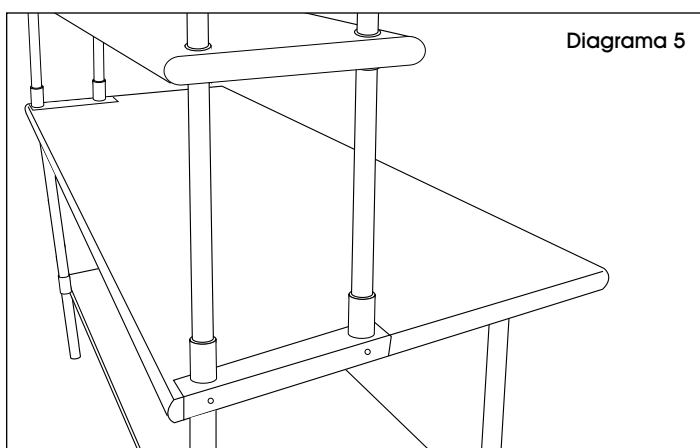

5. Coloque el ensamblaje de las repisas encima de la mesa de trabajo alineando los soportes de repisa con el borde de la mesa en cada extremo. Asegúrese de que ambos lados estén posicionados en el mismo lugar de la cubierta. (Vea Diagrama 5)

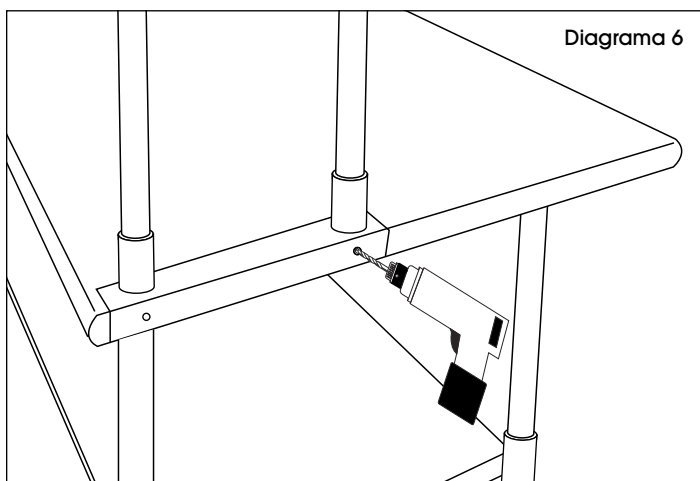

6. Las ranuras de instalación tienen dos orificios en los lados para fijarse a la cubierta. Utilizando los orificios de las ranuras como plantilla, perforo por el lado de la cubierta con la broca de Cobalto incluida. (Vea Diagrama 6)

 **NOTA:** Es posible que se tarde unos segundos para que la broca perforo el material inoxidable.

CONTINUACIÓN DEL ENSAMBLE

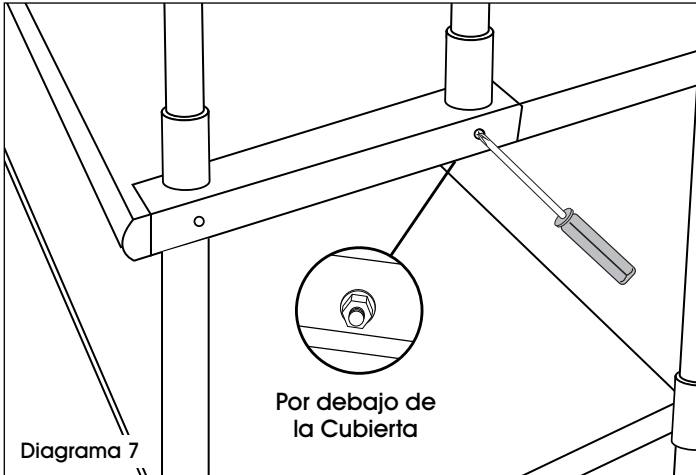

7. Si los orificios perforados son accesibles por debajo de la cubierta, entonces asegure esta parte del soporte de repisa a la cubierta con un perno de cruz M5 x 10 mm y una tuerca con reborde M5 utilizando un desarmador de cruz y una llave de 8 mm. (Vea Diagrama 7)



NOTA: Si los orificios no son accesibles, asegure con un tornillo para lámina de metal utilizando un desarmador de cruz. No se necesitará una tuerca con reborde.

SURMEUBLE EN ACIER INOXYDABLE

1-800-295-5510
uline.ca

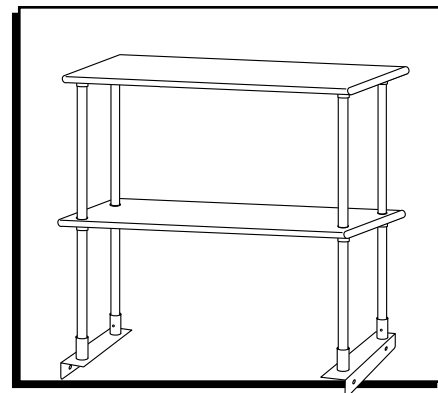

OUTILS REQUIS



Clé Allen de 5/32 po
(inclus)

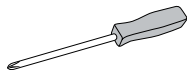

Tournevis
cruiforme



Clé de 8 mm



Mèche de perceuse
cobalt (inclus)

PIÈCES

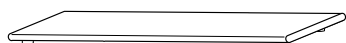

Tablette supérieure x 1



Montant de tablette x 4



Écrou à embase M5 x 4



Vis de réglage
x 12



Vis à tête à tête
cruiforme x 4

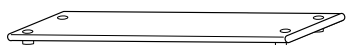

Tablette centrale x 1

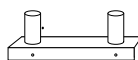

Support de tablette x 2



Boulon à tête cruiforme
M5 x 10 mm x 4



Manchon en
plastique x 4

MONTAGE

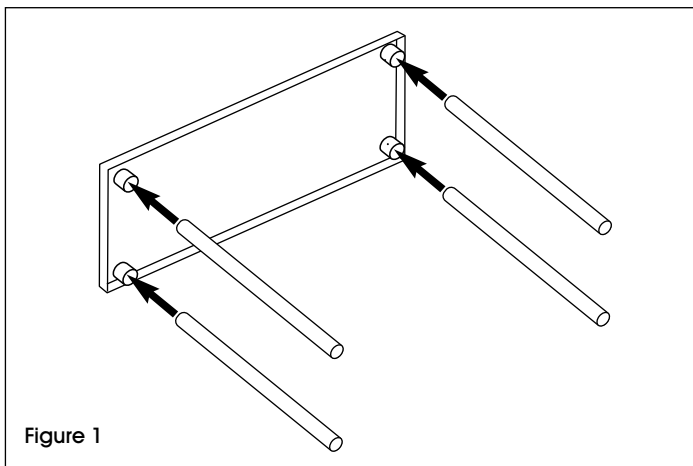

Figure 1

1. Placez la tablette centrale de côté, puis faites passer les montants à travers les bagues de la tablette à la hauteur voulue. Pour vous assurer d'un positionnement exact, marquez la hauteur désirée sur chaque montant avec un marqueur magique ou un crayon à laboratoire. (Voir Figure 1)



REMARQUE : Chaque montant doit être positionné à la même hauteur, faute de quoi les bagues de tablette risqueraient de céder.

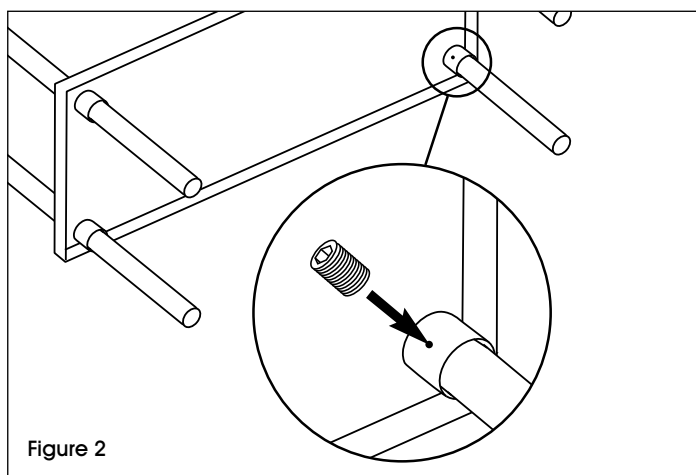
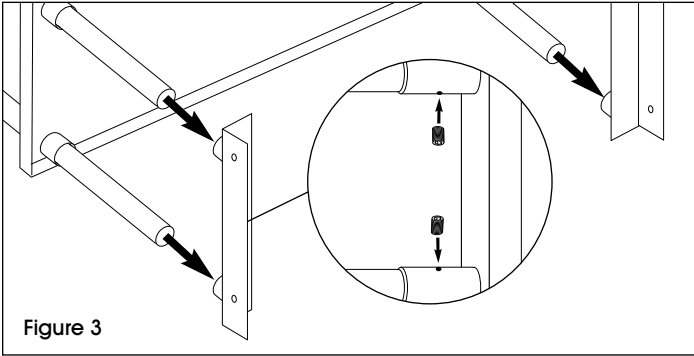

Figure 2

2. Fixez les montants à la tablette centrale à l'aide des vis de réglage et de la clé Allen de 5/32 po. (Voir Figure 2)

MONTAGE SUITE



3. Insérez le bas des montants dans les bagues de support de tablette. Fixez les montants aux supports à l'aide des vis de réglage et de la clé Allen de 5/32 po. (Voir Figure 3)

 **REMARQUE :** L'ouverture des bagues de support doit être orientée vers l'intérieur de l'ensemble.

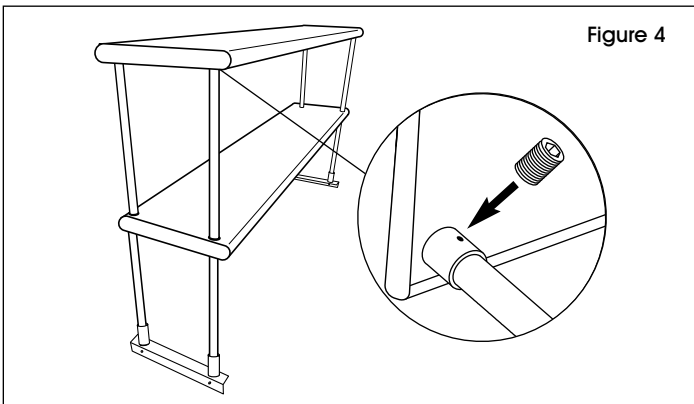

4. Placez l'ensemble debout sur les bagues de support de tablette. Placez la tablette supérieure sur l'ensemble et faites-la glisser en veillant à aligner les bagues de tablette supérieure avec le sommet des montants. Fixez les montants à la tablette supérieure à l'aide des vis de réglage et de la clé Allen de 5/32 po. (Voir Figure 4)

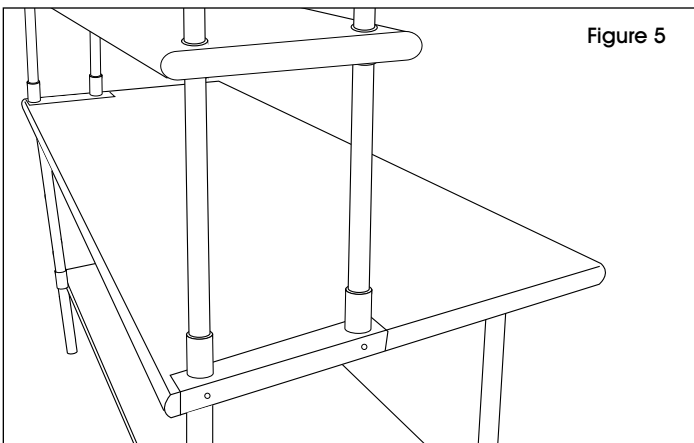

5. Placez l'ensemble de surmeuble sur la table de travail en alignant les supports de tablette avec le bord de chaque extrémité de la table. Assurez-vous que les deux côtés sont positionnés au même niveau sur la surface de la table. (Voir Figure 5)

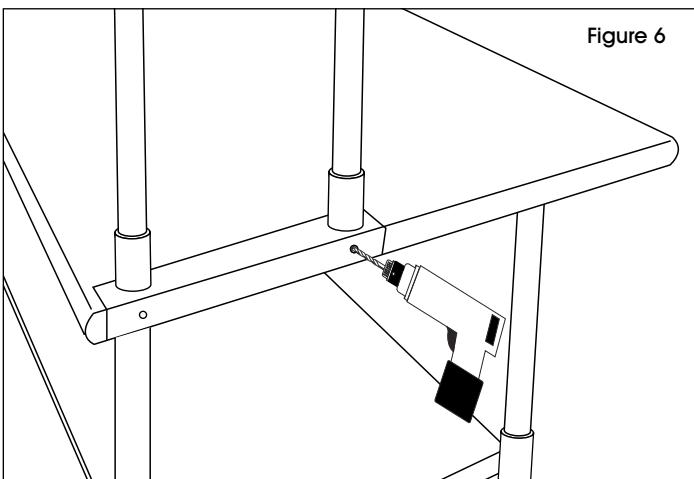

6. Les bagues de montage ont deux trous sur le côté pour permettre la fixation à la surface de table. En vous servant des trous des bagues comme référence, percez le côté de la surface de table avec la mèche de perceuse cobalt. (Voir Figure 6)

 **REMARQUE :** Il se peut que la mèche de perceuse mette quelques secondes pour traverser le matériel inoxydable.

MONTAGE SUITE

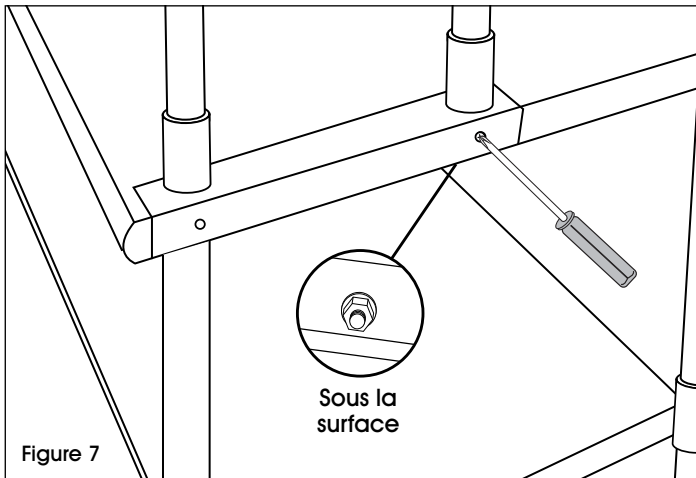

7. Si les trous percés sont accessibles par le dessous de la surface de table, sécurisez cette partie des supports de tablette à la surface de table à l'aide d'un boulon à tête cruciforme M5 x 10 mm et d'un écrou à embase M5, en utilisant un tournevis cruciforme et une clé de 8 mm. (Voir Figure 7)



REMARQUE : Si les trous ne sont pas accessibles, sécurisez le tout à l'aide d'une vis à tôle et d'un tournevis cruciforme. L'écrou à embase ne sera pas utilisé.

ULINE

1-800-295-5510
uline.ca