

ULINE

DELUXE DUST MOP KIT

1-800-295-5510
uline.com

Para Español, vea páginas 3-4.
Pour le français, consulter les pages 5-6.

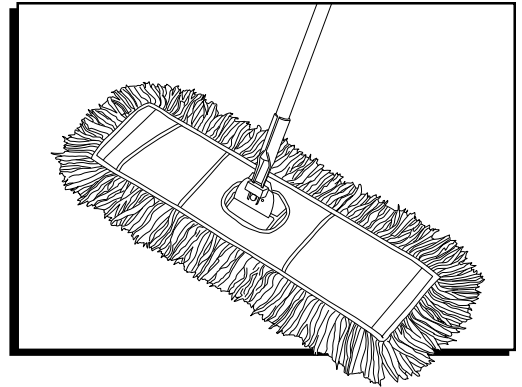

PARTS

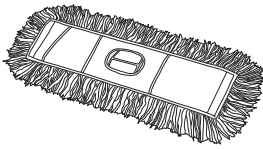

Dust Mop Head x 1

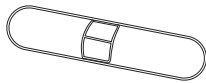

Frame x 1

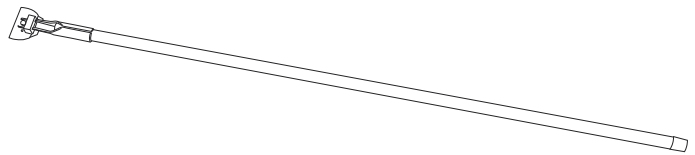

Handle x 1

ASSEMBLY

1. Lay the dust mop head flat, backing side up.
(See Figure 1)

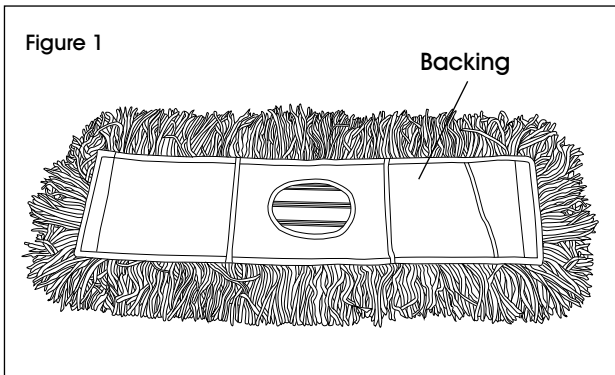

2. Slide the dust mop frame fully into the backing.
(See Figure 2)

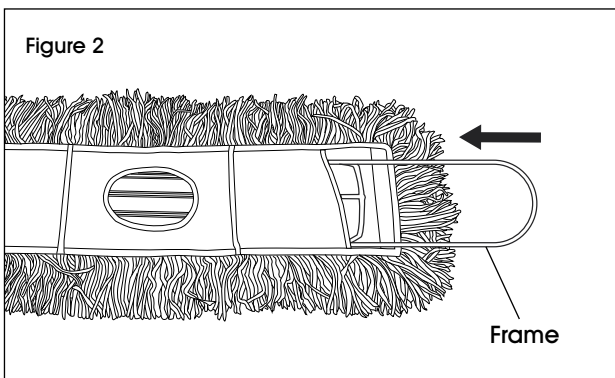

3. Lift the end flap of the dust mop backing up over the exposed end of the frame, fully tucking the frame into the backing. Slide the frame slightly back so that the crossbar is centered in the opening.
(See Figures 3-4)

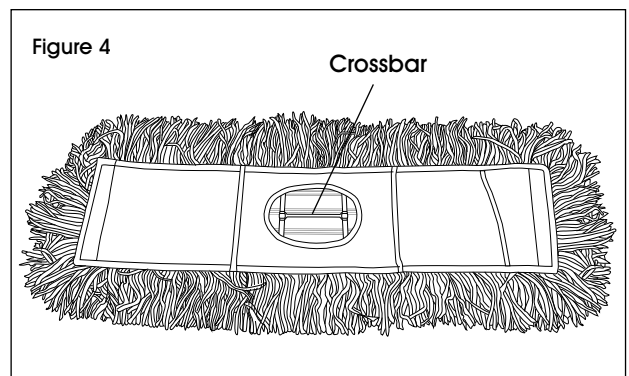
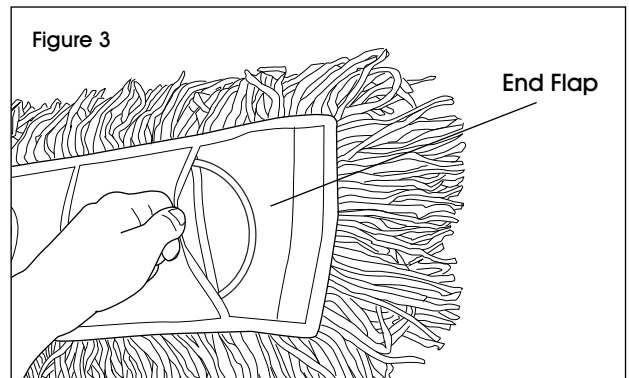

ASSEMBLY CONTINUED

4. Clamp the handle onto the dust mop frame crossbar. (See Figures 5-6)

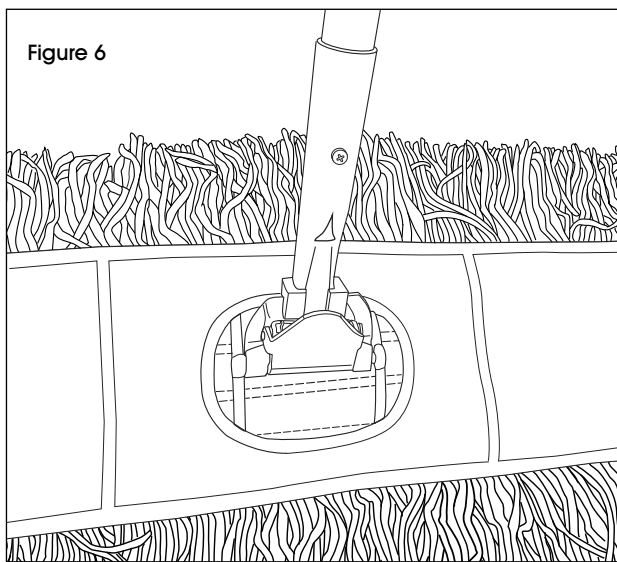
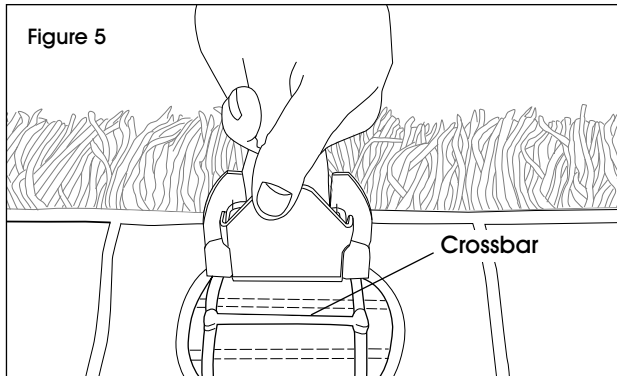

5. The dust mop handle swivels 360°. To allow the handle to fully swivel in any direction, push the sliding nylon collar up. (See Figure 7)

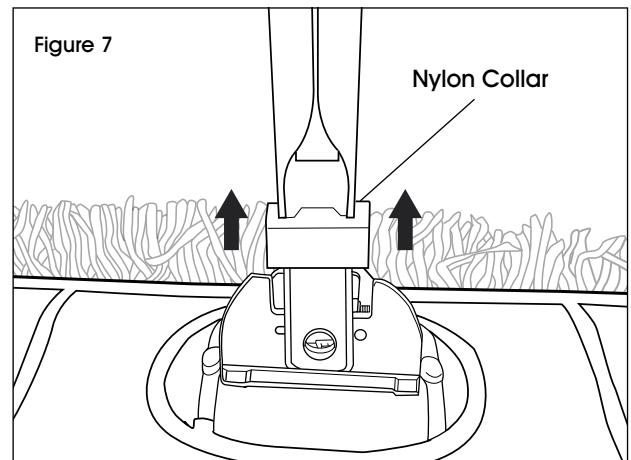

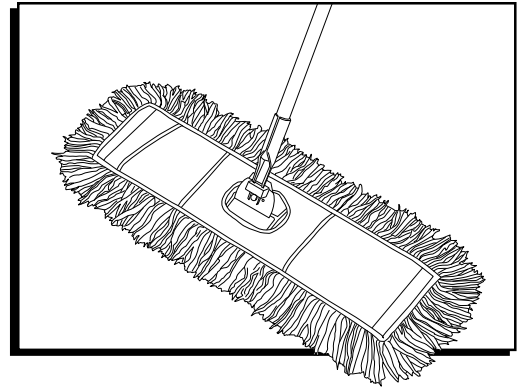
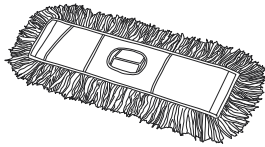
**PARTES**

1 Cabeza del Trapeador

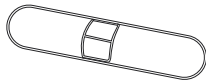

1 Armazón

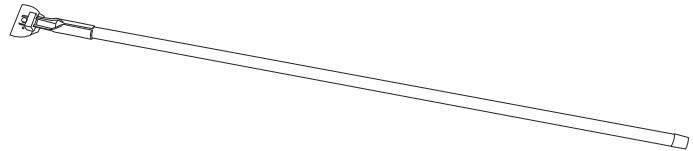

1 Mango

ENSAMBLE

1. Extienda la cabeza del trapeador para polvo con el lado del soporte hacia arriba. (Vea Diagrama 1)

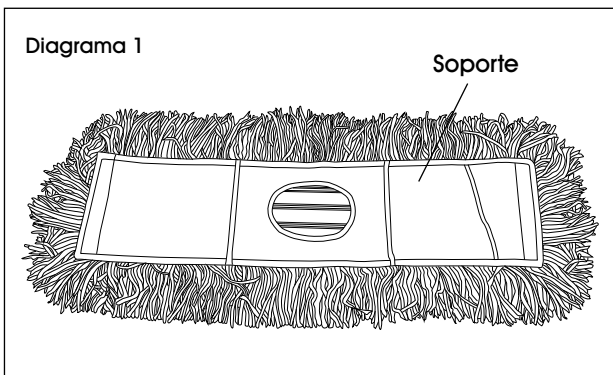

2. Deslice el armazón del trapeador para polvo completamente dentro del soporte. (Vea Diagrama 2)

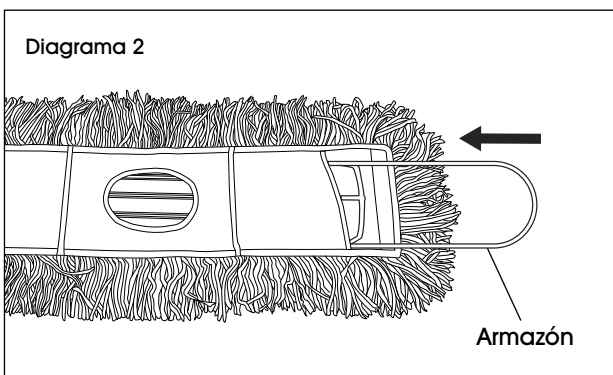

3. Levante la solapa del extremo del soporte del trapeador para polvo por encima del extremo expuesto del armazón e introdúzcalo completamente dentro del soporte. Deslice el armazón levemente hacia atrás de modo que la barra transversal quede al centro de la abertura. (Vea Diagramas 3-4)

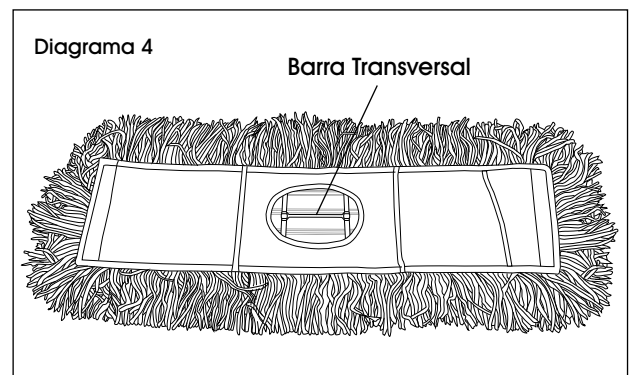
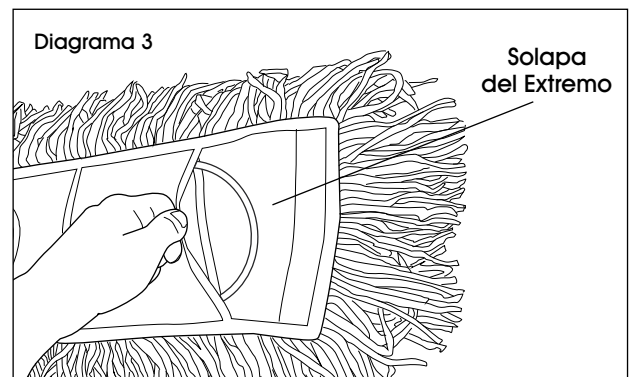

CONTINUACIÓN DEL ENSAMBLE

4. Sujete el mango en la barra transversal del armazón del 0 de polvo. (Vea Diagramas 5-6)

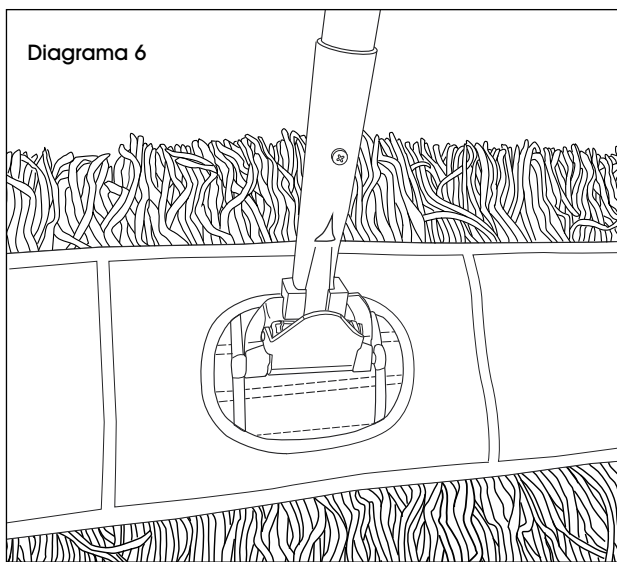
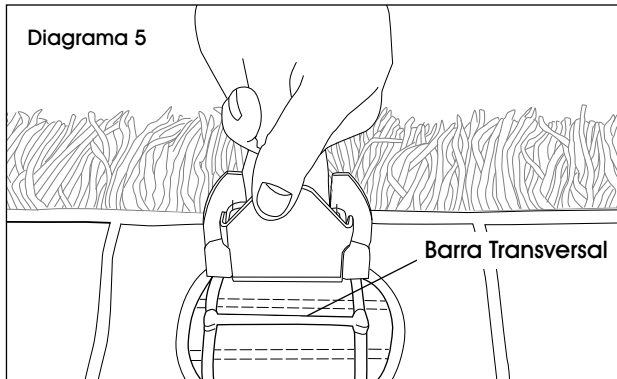

5. El mango del trapeador para polvo gira 360°. Para permitir que el mango gire en cualquier dirección, jale el collar de nylon deslizante hacia arriba. (Vea Diagrama 7)

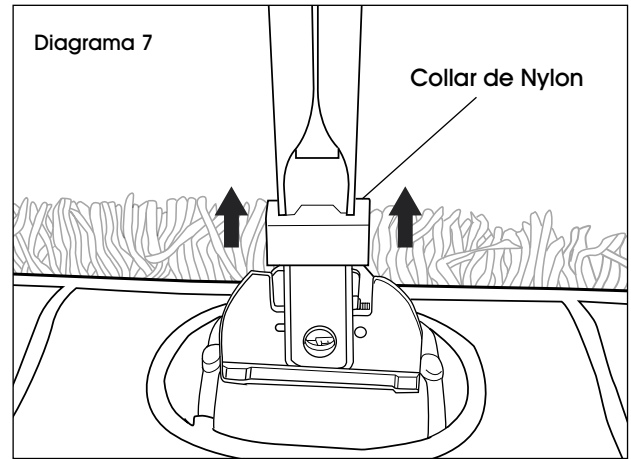

ULINE

ENSEMBLE DE VADROUILLE ANTIPOUSSIÈRE DE LUXE

1-800-295-5510

uline.ca

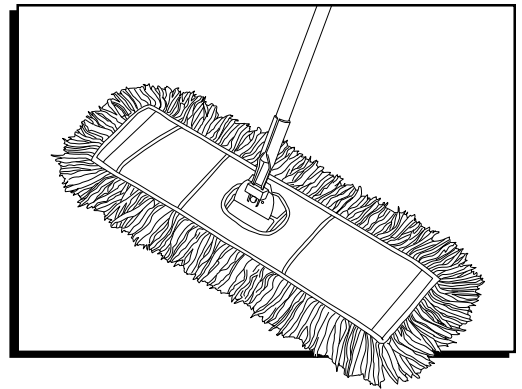

PIÈCES

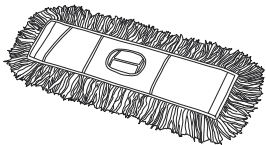

Tête de vadrouille antipoussière x 1

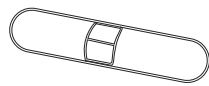

Cadre x 1

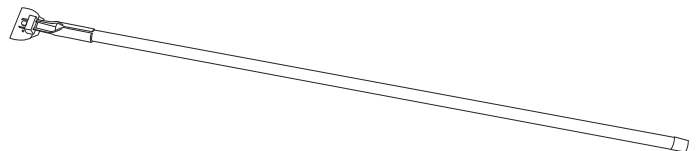

Manche x 1

MONTAGE

1. Placez la tête de la vadrouille antipoussière à plat de sorte que le support soit orienté vers le haut. (Voir Figure 1)

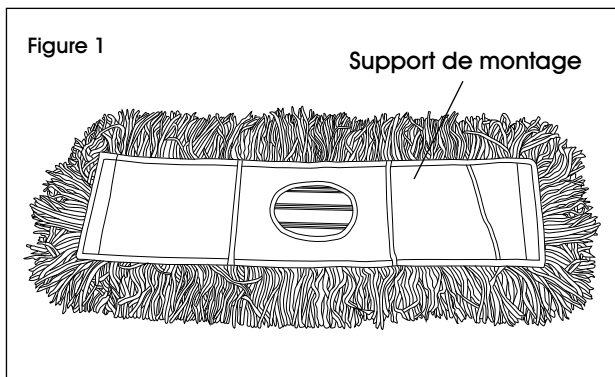

2. Insérez le cadre au complet de la vadrouille antipoussière en-dessous du support. (Voir Figure 2)

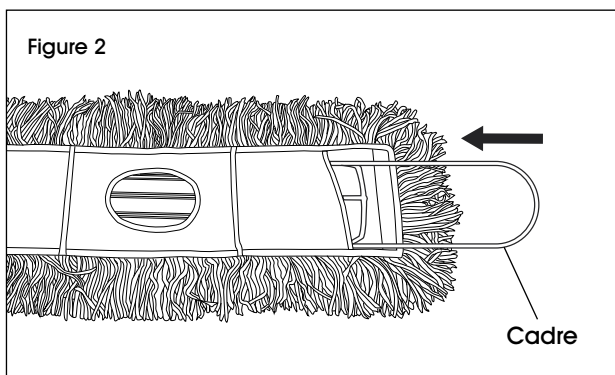

3. Soulevez le rabat d'extrémité sur le support de montage pour recouvrir l'extrémité découverte du cadre et insérez le cadre au complet de la vadrouille en-dessous du support. Insérez le cadre en l'inclinant légèrement vers l'arrière pour que la barre transversale soit centrée dans l'ouverture. (Voir Figures 3 et 4)

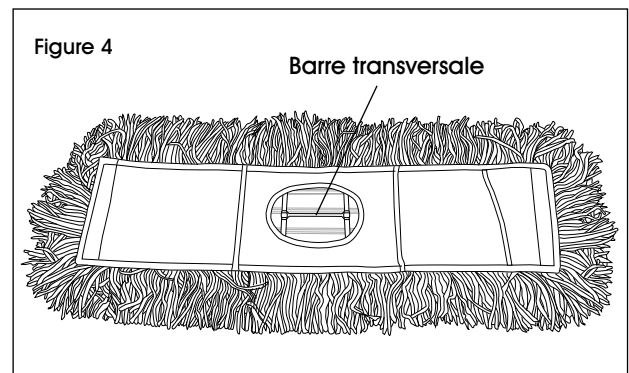
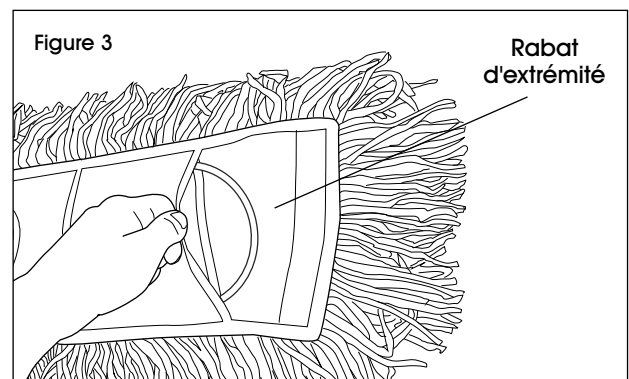

MONTAGE SUITE

4. Fixez le manche sur la barre transversale du cadre de la vadrouille antipoussière. (Voir Figures 5 et 6)

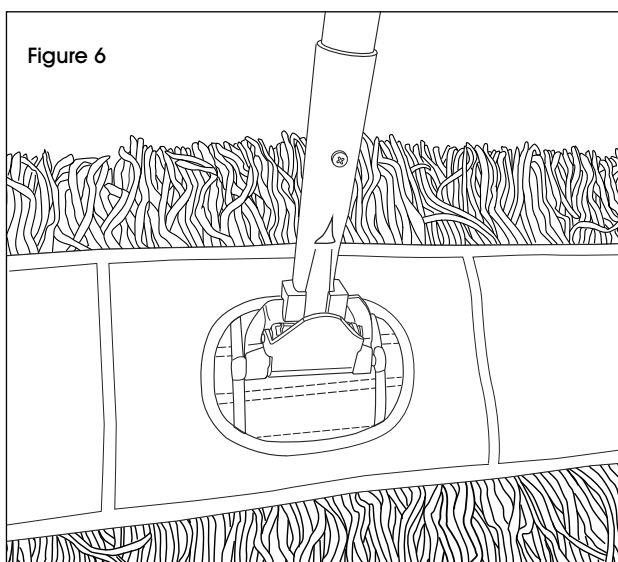
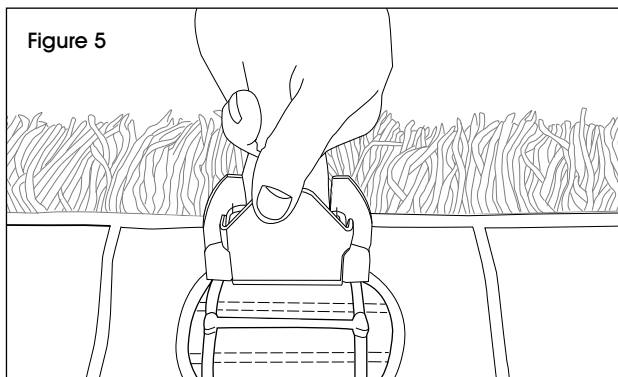

5. Le manche de la vadrouille antipoussière pivote sur 360°. Pour permettre au manche de pivoter dans tous les sens, faites glisser le collier coulissant en nylon vers le haut. (Voir Figure 7)

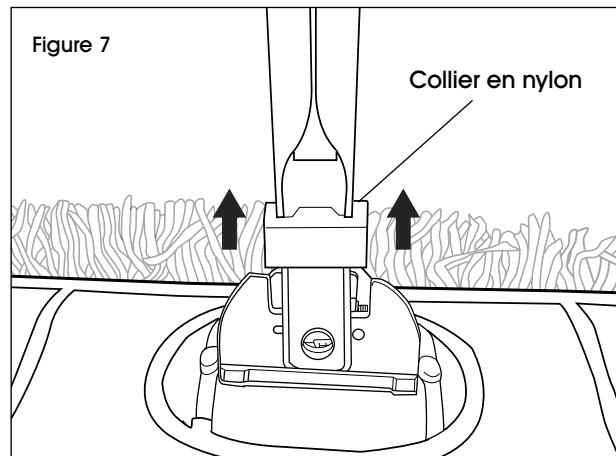

ULINE

1-800-295-5510
uline.ca