

ULINE H-8710, H-8711
H-10737, H-11885
OUTDOOR SAFETY CABINET

1-800-295-5510
uline.com

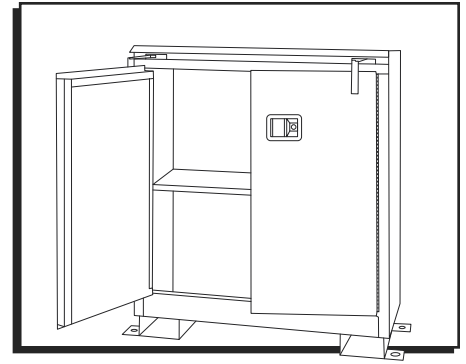

INSTALLATION

1. There are two options for installing fusible links.
(See Figure 1)
 - a. To hold doors open at 90° angle, connect link using hole A.
 - b. To hold doors open at 180° angle, connect link using hole B.



NOTE: For maintenance, oil the three spring latches periodically to ensure proper door latching.

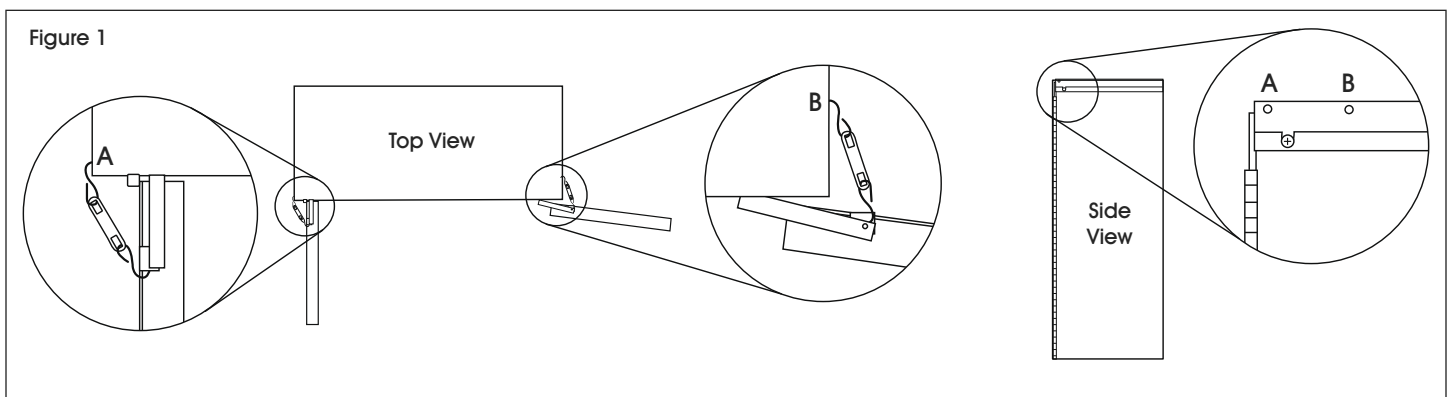



H-8710, H-8711
H-10737, H-11885

GABINETE DE SEGURIDAD PARA EXTERIORES

800-295-5510
uline.mx

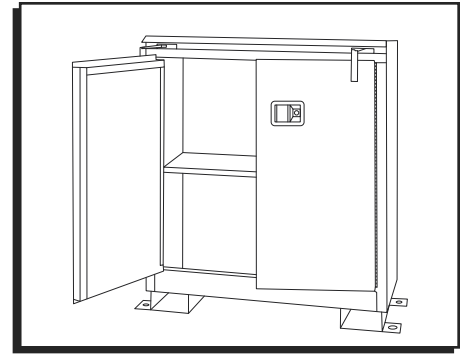

INSTALACIÓN

1. Hay dos opciones para instalar eslabones fusibles.
(Vea Diagrama 1)
 - a. Para mantener las puertas abiertas a un ángulo de 90°, conecte el eslabón utilizando el orificio A.
 - b. Para mantener las puertas abiertas a un ángulo de 180°, conecte el eslabón utilizando el orificio B.



NOTA: Para mantenimiento, lubrique periódicamente los tres pestillos con resorte para asegurar el cierre adecuado de la puerta.

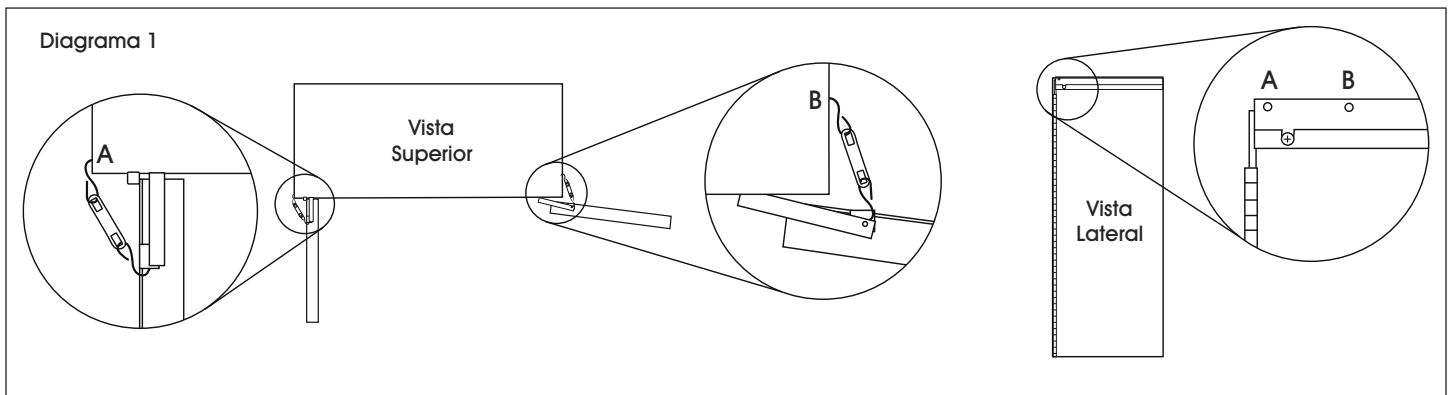

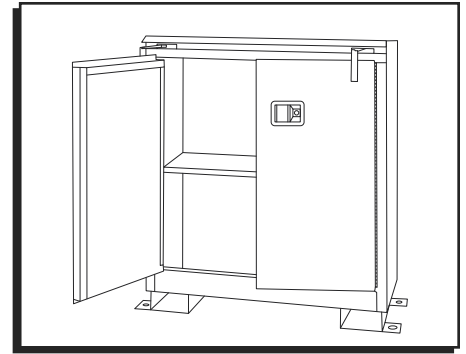

INSTALLATION

1. Il existe deux options pour installer les maillons fusible. (Voir Figure 1)
 - a. Pour maintenir les portes ouvertes à un angle de 90°, connectez les maillons à l'aide du trou A.
 - b. Pour maintenir les portes ouvertes à un angle de 180°, connectez les maillons à l'aide du trou B.



REMARQUE : Pour l'entretien, huilez les trois loquets à ressort régulièrement pour garantir un verrouillage adéquat de la porte.

