

ULINE H-8796, H-8797
H-11601
FLAT FILE CABINET

1-800-295-5510
uline.com

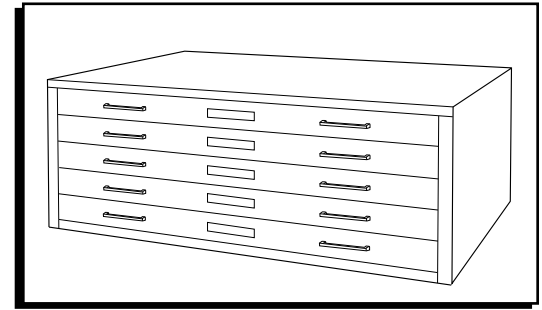

TOOLS NEEDED



Phillips Screwdriver

Flathead Screwdriver

10 mm Wrench

Rubber Mallet

PARTS



Handle x 10



M6 x 55 mm Bolt x 2



M4 x 6 mm Handle Screw x 20



M4 Washer x 20



M6 Nut x 2

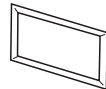

Label Holder x 5

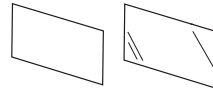

Paper Label and Plastic Cover x 5

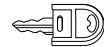

Key x 2

ASSEMBLY

HANDLES AND LABEL HOLDERS

1. Place handle on front of drawer and insert two M4 x 6 mm handle screws with two M4 washers through opposite side. Tighten using a Phillips screwdriver. Repeat for all drawers. (See Figure 1)

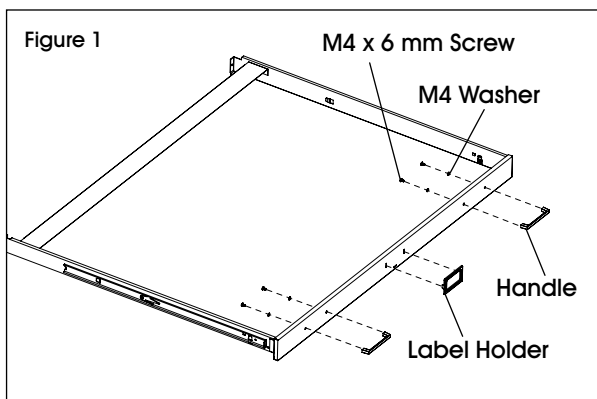

2. Attach label holders by pushing tabs through slots in front of drawer and bending tabs on back of drawer toward center to secure.

STACKING

1. Remove bottom drawer of top unit and top drawer of bottom unit. To remove drawer, pull up on one tab and push down on the opposite tab, then pull cabinet body out. (See Figure 2)

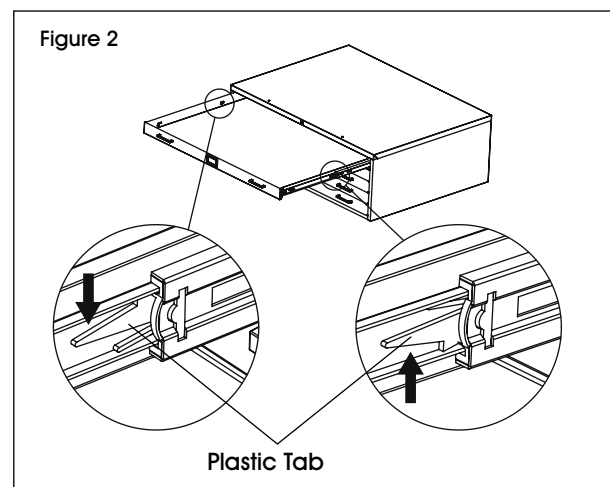

ASSEMBLY CONTINUED

2. Remove knockout caps on top of bottom unit.
(See Figure 3)



NOTE: Knockout caps can be removed using a flathead screwdriver and rubber mallet. Stand the flathead screwdriver on the knockout caps and tap the top of the screwdriver handle with the rubber mallet to knock the caps off.

3. Stack units and align holes at front ledge of units.
Insert M6 x 55 mm bolts into top and bottom unit.
Attach M6 nuts and tighten to secure. (See Figure 3)

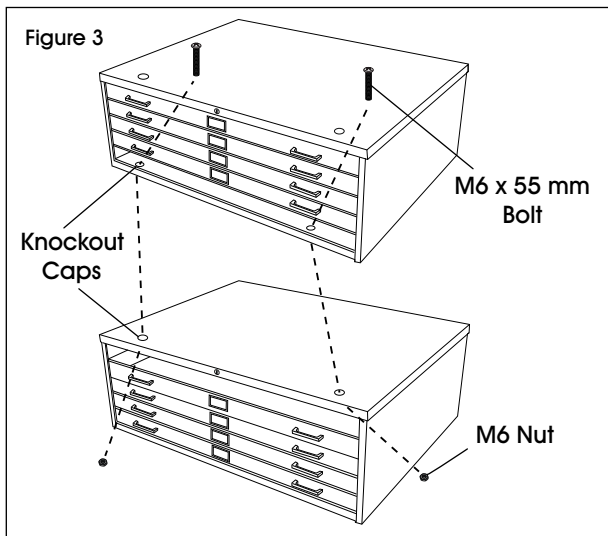

ULINE

1-800-295-5510
uline.com

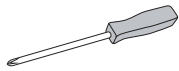
ULINEH-8796, H-8797
H-11601800-295-5510
uline.mx**ARCHIVERO PLANO****HERRAMIENTAS NECESARIAS**

Desarmador de Cruz

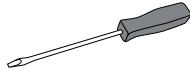

Desarmador Plano



Llave de 10 mm

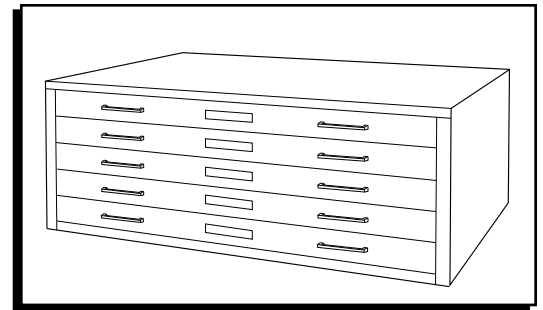

Mazo de Caucho

**PARTES**

10 Asas



2 Pernos M6 x 55 mm



20 Tornillos para Asa M4 x 6 mm



20 Rondanas M4



2 Tuercas M6

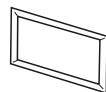

5 Portaetiquetas

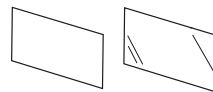

5 Etiquetas de Papel y Cubiertas de Plástico



2 Llaves

ENSAMBLE**ASAS Y PORTAETIQUETAS**

- Coloque el asa al frente del cajón e inserte en el lado opuesto dos tornillos para asa M4 x 6 mm con dos rondanas M4. Apriete utilizando un desarmador de cruz. Repita la operación para todos los cajones. (Vea Diagrama 1)

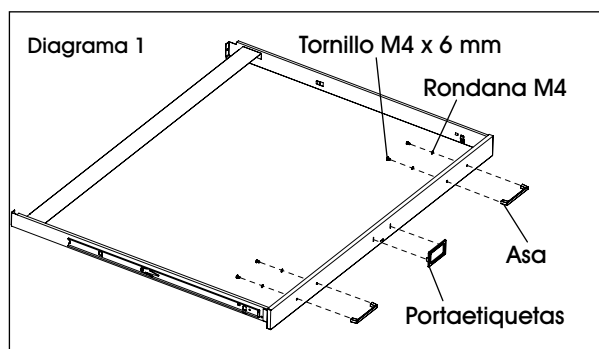

- Fije los portaetiquetas empujando la pestaña en las ranuras al frente del cajón y doblando las pestañas en la parte posterior del cajón hacia el centro para asegurarlas.

ESTIBAR

- Retire el cajón inferior de la unidad superior y el cajón superior de la unidad inferior. Para quitar el cajón, jale hacia arriba una de las pestañas y hacia abajo la pestaña opuesta, luego, saque el cuerpo del gabinete. (Vea Diagrama 2)

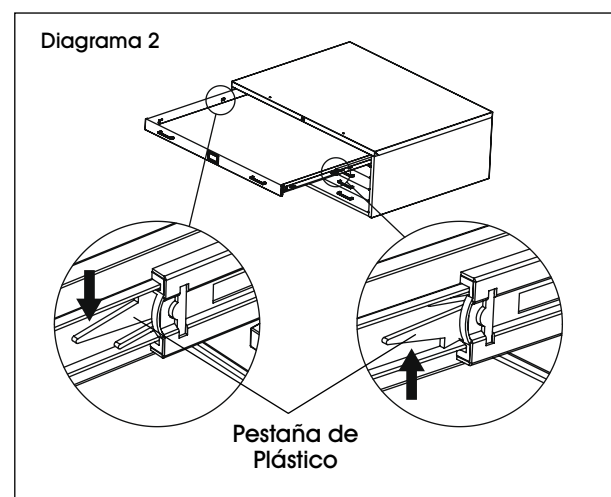

CONTINUACIÓN DE ENSAMBLE

2. Retire los tapones que están en la parte superior de la unidad inferior. (Vea Diagrama 3)

 **NOTA:** Puede quitar los tapones utilizando un desarmador de cabeza plana y mazo de caucho. Coloque el desarmador de cabeza plana en los tapones y golpee la parte superior del mango del desarmador con el mazo de caucho para sacar los tapones.

3. Estibe las unidades y alinee los orificios al borde frontal de las unidades. Inserte los pernos M6 x 55 mm en la parte superior e inferior de la unidad. Fije las tuercas M6 y apriete para asegurar. (Vea Diagrama 3)

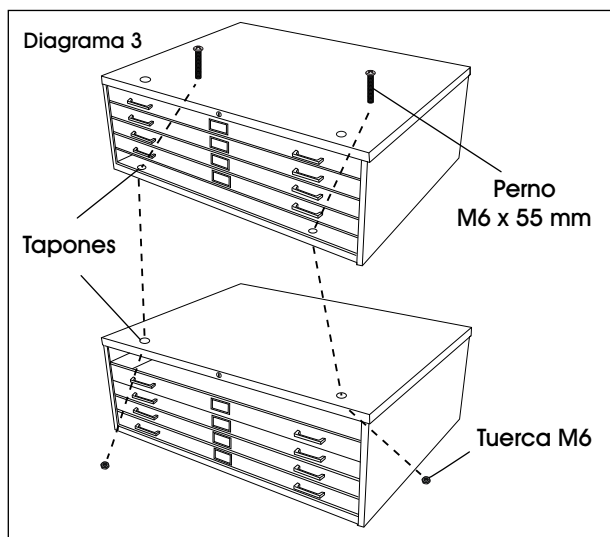

CLASSEUR PLAT

OUTILS REQUIS

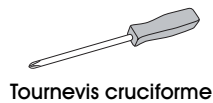

Tournevis cruciforme

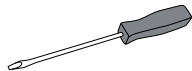

Tournevis à tête plate

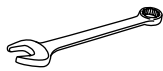

Clé de 10 mm



Maillet en caoutchouc

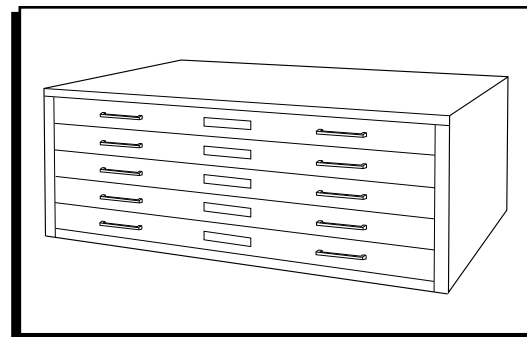

PIÈCES



Poignée x 10



Boulon M6 x 55 mm x 2



Vis de poignée M4 x 6 mm x 20



Rondelle M4 x 20



Écrou M6 x 2

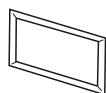

Porte-étiquette x 5

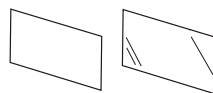

Étiquette en papier et protection en plastique x 5



Clé x 2

ASSEMBLAGE

POIGNÉES ET PORTE-ÉTIQUETTES

1. Placez la poignée sur le devant du tiroir et insérez deux vis de poignée M4 x 6 mm avec deux rondelles M4 du côté opposé. Serrez le tout en vous servant d'un tournevis cruciforme. Répétez pour tous les tiroirs. (Voir Figure 1)

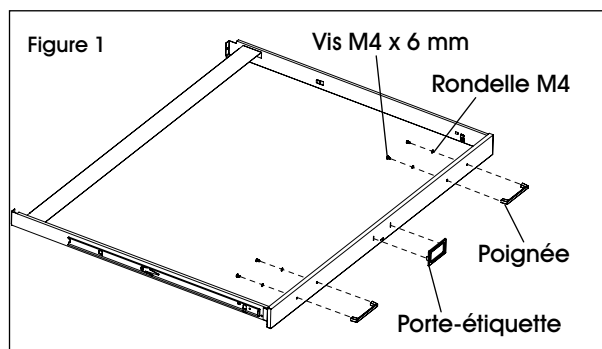

2. Fixez les porte-étiquettes en poussant les languettes dans les fentes à l'avant du tiroir et en pliant les languettes à l'arrière vers le centre.

EMPILAGE

1. Retirez le tiroir inférieur de l'unité supérieure et le tiroir supérieur de l'unité inférieure. Pour retirer le tiroir, tirez vers le haut sur une languette et poussez vers le bas sur la languette opposée, puis tirez le corps du tiroir vers l'extérieur. (Voir Figure 2)

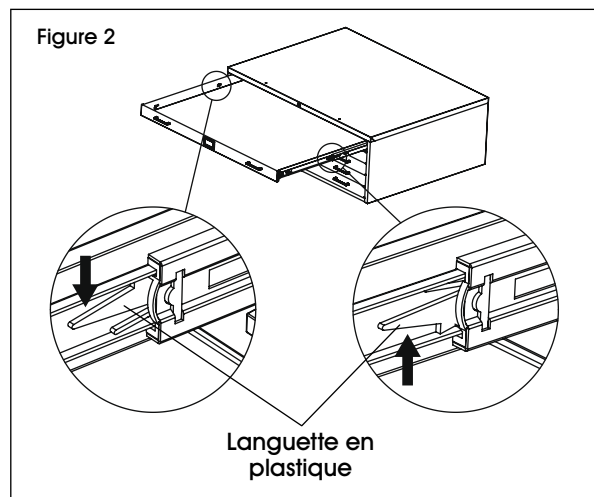

ASSEMBLAGE SUITE

2. Enlevez les capuchons de protection sur le dessus de l'unité inférieure. (Voir Figure 3)



REMARQUE : Les capuchons de protection peuvent être retirés à l'aide d'un tournevis à tête plate et d'un maillet en caoutchouc. Placez le tournevis à tête plate sur les capuchons de protection et tapez sur le dessus du manche du tournevis avec le maillet en caoutchouc pour faire tomber les capuchons.

3. Empilez les unités et alignez les trous sur le rebord avant des unités. Insérez les boulons M6 x 55 mm dans les unités supérieure et inférieure. Fixez les écrous M6 et serrez le tout. (Voir Figure 3)

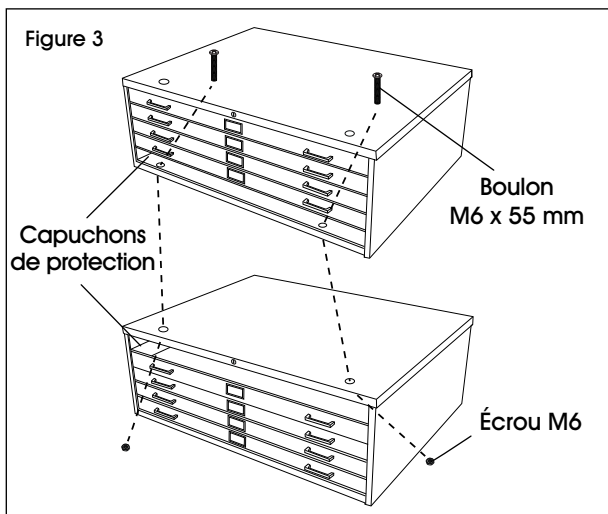

ULINE

1 800 295-5510
uline.ca