

ULINE H-8867F, H-8868F, H-8869F
H-8871F, H-8872F, H-8873F

1-800-295-5510
uline.com

FREESTANDING PRIVACY PANEL

TOOL NEEDED

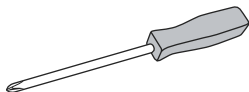

Phillips Head Screwdriver

TOOL INCLUDED

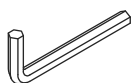

Allen Wrench 5 mm

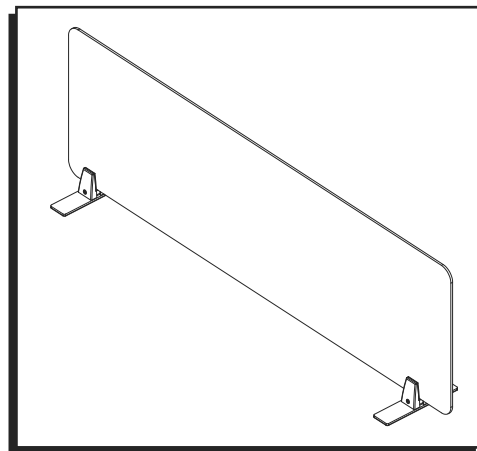

PARTS

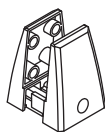

Bracket x 2



Plastic Mat x 4

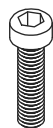

Allen Screw x 2
M6 x 20 mm



Phillips Head Screw x 4
M5 x 6 mm

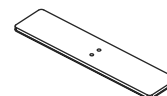

Metal Plate x 2

INSTRUCTIONS

 **NOTE:** Remove protective film from acrylic panels before assembling.

1. Separate bracket into front and rear pieces. Align rear bracket with holes on top side of metal plate and attach using two M5 x 6 mm screws. Tighten screws using Phillips head screwdriver. (See Figure 1)

Figure 1

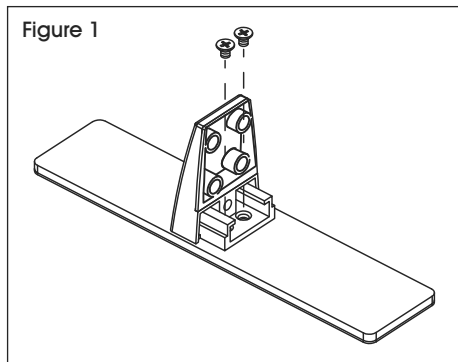

2. Firmly press one plastic mat to each inside wall of bracket. Insert M6 x 20 mm screw through hole on outside of front bracket. Slide front bracket over rear bracket to connect. Leave space between front and rear bracket pieces and insert panel between them. Firmly press the two bracket pieces together and tighten the M6 x 20 mm screw using 5 mm Allen wrench. (See Figure 2)

 **NOTE:** Repeat both steps for bracket on opposite end of panel.

Figure 2



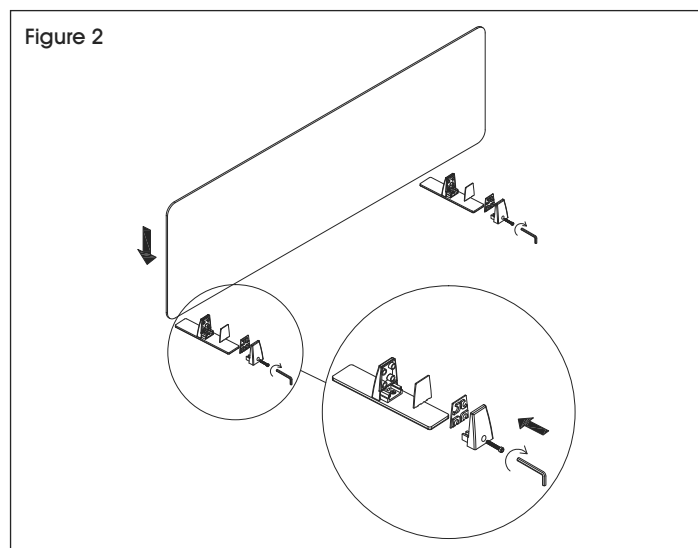

H-8867F, H-8868F, H-8869F
H-8871F, H-8872F, H-8873F

800-295-5510
uline.mx

PANEL DE PRIVACIDAD CON SOPORTES INDEPENDIENTES

HERRAMIENTA NECESARIA

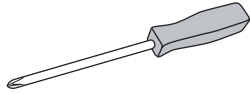

Desarmador de Cruz

HERRAMIENTA INCLUIDA

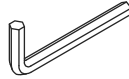

Llave Allen de 5 mm

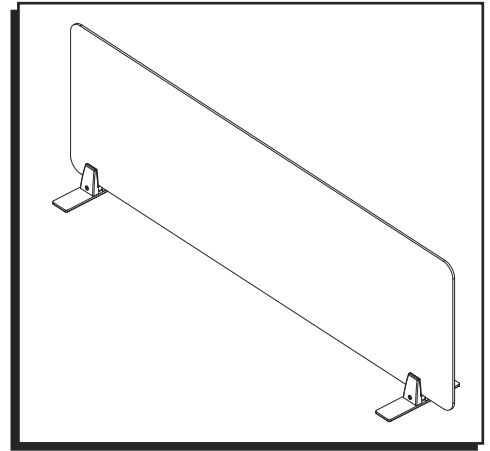

PARTES

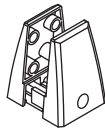

2 Soportes



4 Láminas de Plástico

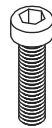

2 Tornillos de Cabeza Allen M6 x 20 mm



4 Tornillos de Cabeza de Cruz M5 x 6 mm

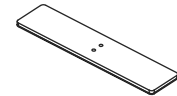

2 Placas de Metal

INSTRUCCIONES

NOTA: Antes de ensamblar, retire la película protectora de los paneles de acrílico.

1. Separe el soporte en piezas frontales y posteriores. Alinee el soporte de acero posterior con los orificios que están debajo de la placa de metal y fíjelo usando dos tornillos M5 x 6 mm. Apriete los tornillos con un desarmador de cruz. (Vea Diagrama 1)

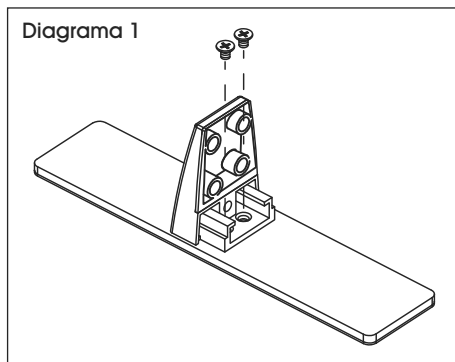

2. Presione firmemente una lámina de plástico en cada pared interior del soporte. Inserte un tornillo M6 x 20 mm por el orificio de la parte exterior del soporte frontal. Deslice el soporte frontal por encima del soporte posterior para conectarlo. Deje un espacio entre las piezas de los soportes frontal y posterior e inserte el panel entre ellos. Presione firmemente las piezas de los soportes y apriete el tornillo M6 x 20 mm usando una llave Allen de 5 mm. (Vea Diagrama 2)

NOTA: Repita estos pasos para el soporte en el extremo opuesto del panel.

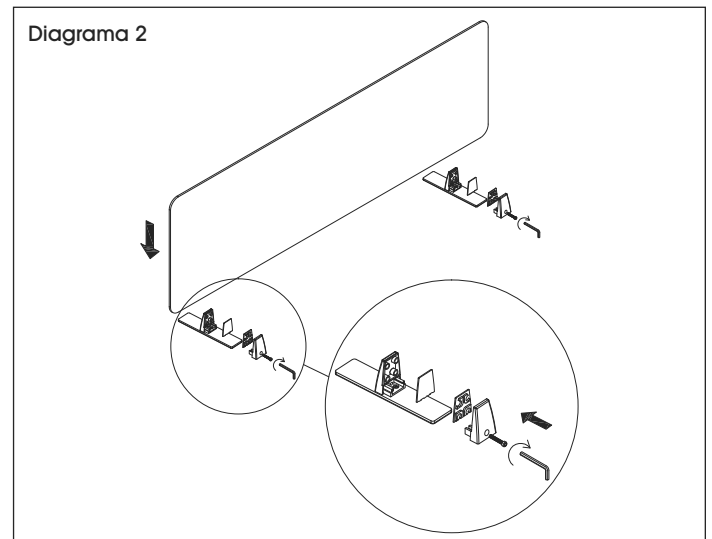

PANNEAU DE SÉPARATION SUR PIED

OUTIL REQUIS

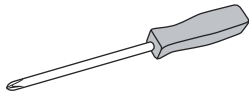

Tournevis cruciforme

OUTIL INCLUS

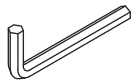

Clé Allen 5 mm

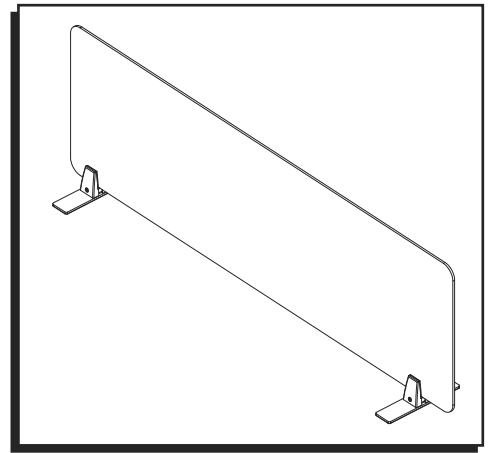

PIÈCES

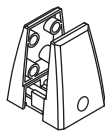

Support x 2



Couche de
plastique x 4



Vis creuse x 2
M6 x 20 mm



Vis cruciforme x 4
M5 x 6 mm

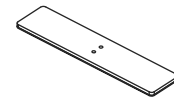

Plaque en
métal x 2

INSTRUCTIONS

 **REMARQUE :** Retirez la pellicule protectrice des panneaux en acrylique avant le montage.

1. Séparez le support en deux parties, avant et arrière. Alignez le support arrière avec les trous du côté supérieur de la plaque métallique. Fixez-le à l'aide de deux vis M5 x 6 mm. Serrez les vis à l'aide du tournevis cruciforme. (Voir Figure 1)

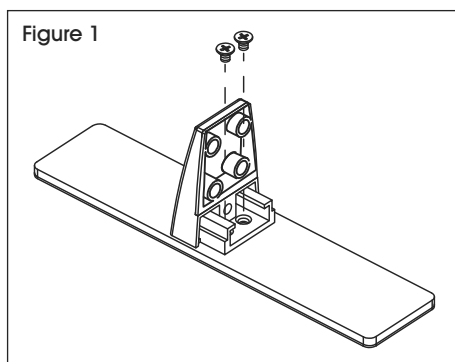

2. Pressez fermement une couche de plastique contre chacune des parois intérieures du support. Insérez une vis M6 x 20 mm dans le trou situé à l'extérieur du support avant. Faites glisser le support avant sur le support arrière pour les relier. Laissez de l'espace entre les pièces de support avant et arrière, et insérez un panneau entre les deux. Pressez fermement les deux pièces du support l'une contre l'autre et serrez la vis M6 x 20 mm à l'aide de la clé Allen de 5 mm. (Voir Figure 2)

 **REMARQUE :** Répétez les mêmes étapes pour le support à l'autre bout du panneau.

