

ULINE H-9014

SIT/STAND MOBILE DESK

1-800-295-5510
uline.com

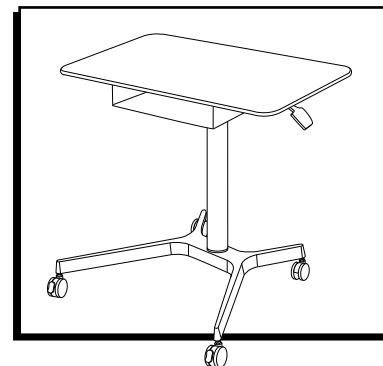

TOOLS NEEDED



5 mm Allen Wrench
6 mm Allen Wrench
(included)

PARTS



Tabletop x 1

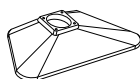

Plastic Mount Plate x 1

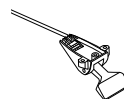

Height Adjustment Lever x 1



Swivel Caster x 2



Center Post x 1

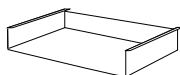

Lower Shelf x 1



Base x 1



Locking Caster x 2

Hardware Kit



M8 x 15 mm
Bolt x 4



M6 x 20 mm
Bolt x 7



M6 x 15 mm
Bolt x 6



M6 x 12 mm
Bolt x 4



Locking
Washer x 3



Washer x 3

ASSEMBLY

 **NOTE:** Count and inspect all pieces before disposing of any carton or packing materials.

1. Insert four M8 x 15 bolts (1) into plastic mount plate to attach to center post. Tighten using 6 mm Allen wrench. (See Figure 1)

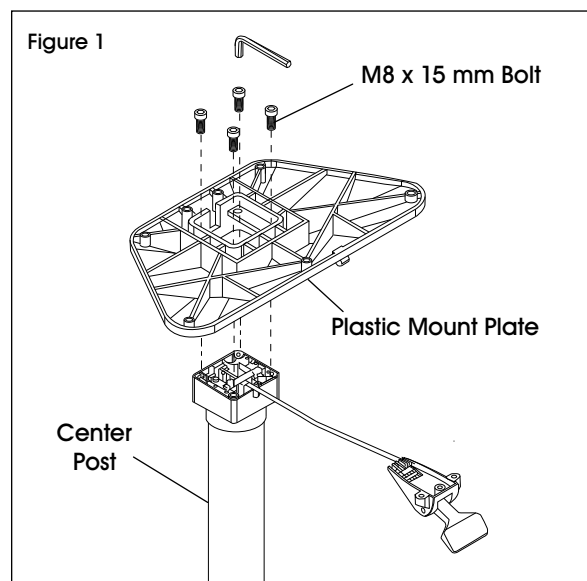

ASSEMBLY CONTINUED

- Place tabletop face down on non-marring surface, so the pre-drilled holes face up. Align holes on plastic mount plate with pre-drilled holes on tabletop and insert seven M6 x 20 mm bolts (2) to attach. Insert three M6 x 15 mm bolts (3) to attach the height adjustment lever to underside of tabletop. (See Figure 2)

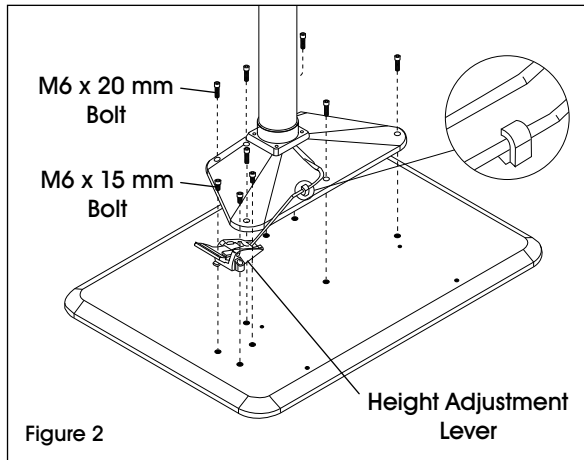

- Align holes on lower shelf with pre-drilled holes on underside of tabletop and insert four M6 x 12 mm bolts (4) to attach. Lip on shelf indicates back side of shelf. (See Figure 3)

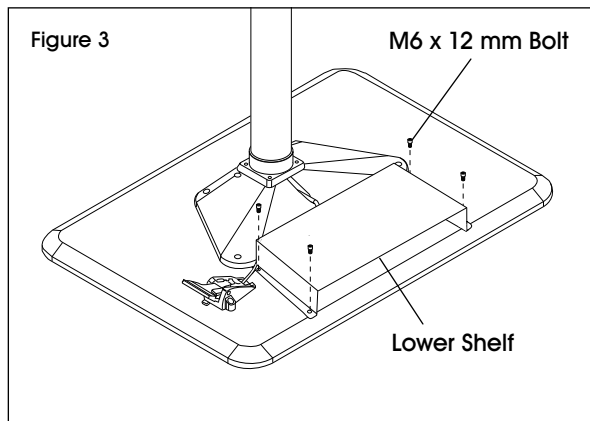

- Turn the base upside down and place it on the bottom of the center post. Match the three holes on the bottom of the base with the three holes in the center post. Use three M6 x 15 mm bolts (3), three locking washers (5) and three washers (6) to secure base to center post. Fully tighten using 5 mm Allen wrench. (See Figure 4)

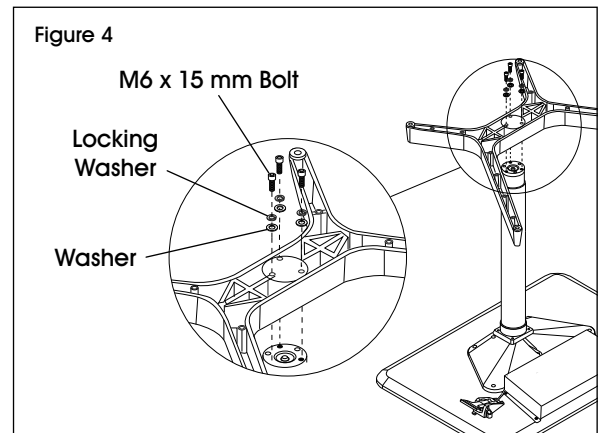

- Insert locking casters into the long legs of the base, and insert swivel casters into the short legs of the base. (See Figure 5)

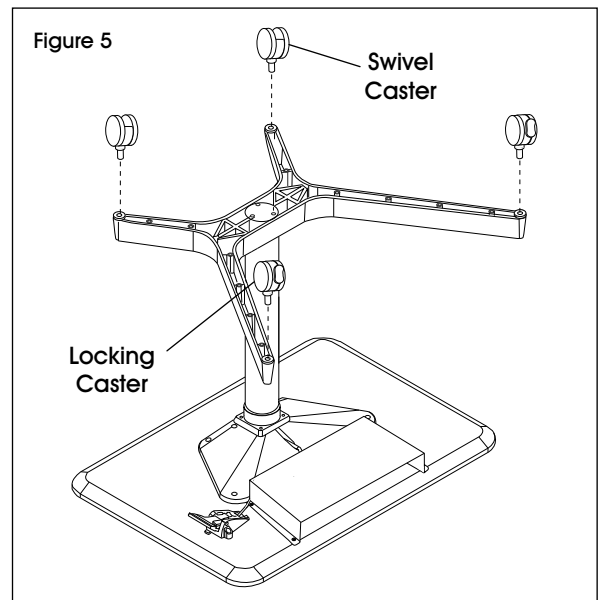

- Desk is now fully assembled. Using two people, carefully flip the desk onto the casters.

ULINE

1-800-295-5510
uline.com

ULINE H-9014

ESCRITORIO MÓVIL PARA TRABAJAR DE PIE O SENTADO

800-295-5510
uline.mx

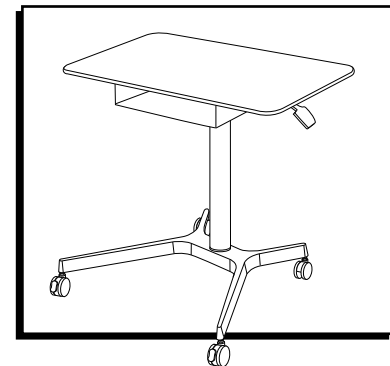

HERRAMIENTAS NECESARIAS



Llave Allen de 5 mm
Llave Allen de 6 mm
(incluidas)

PARTES



1 Cubierta

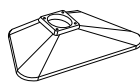

1 Placa de Instalación de Plástico

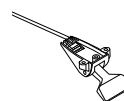

1 Palanca de Ajuste de Altura

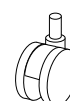

2 Ruedas Giratorias



1 Poste Central

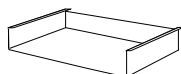

1 Repisa Inferior



1 Base

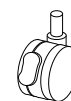

2 Ruedas con Seguro

Kit de Accesorios



4 Pernos
M8 x 15 mm



7 Pernos
M6 x 20 mm



6 Pernos
M6 x 15 mm



4 Pernos
M6 x 12 mm



3 Rondanas de
Seguridad



3 Rondanas

ENSAMBLE



NOTA: Cuente e inspeccione todas las piezas antes de desechar cualquier caja o material de empaque.

1. Inserte cuatro pernos M8 x 15 mm (1) en la placa de instalación de plástico para fijar al poste central. Apriete con la llave Allen de 6 mm. (Vea Diagrama 1)

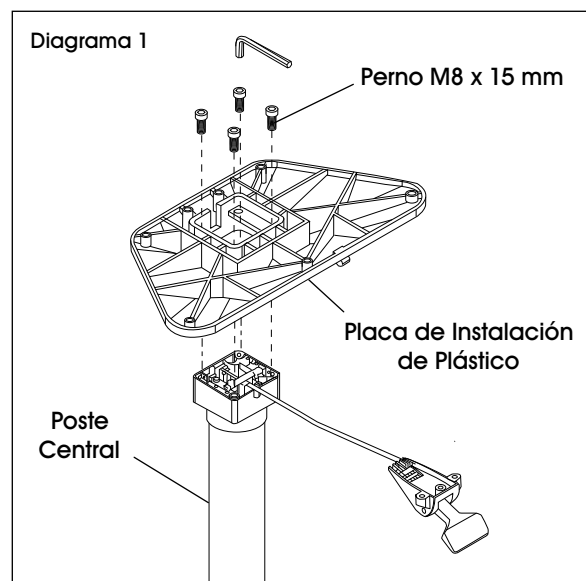

CONTINUACIÓN DE ENSAMBLE

- Coloque la cubierta bocabajo sobre una superficie que no deje marcas, para que los orificios preperforados queden boca arriba. Alinee los orificios de la placa de instalación de plástico con los orificios preperforados de la cubierta e inserte siete pernos M6 x 20 mm (2) para fijar. Inserte tres pernos M6 x 15 mm (3) para fijar la palanca de ajuste de altura a la parte inferior de la cubierta. (Vea Diagrama 2)

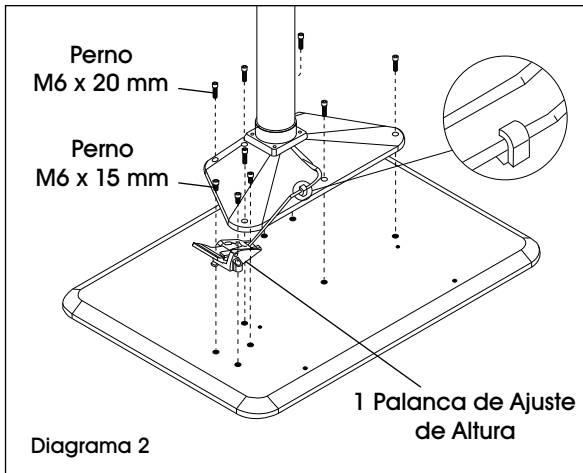

- Alinee los orificios de la repisa inferior con los orificios preperforados en la parte inferior de la cubierta e inserte cuatro pernos M6 x 12 mm (4) para fijar. El borde de la repisa indica su lado posterior. (Vea Diagrama 3)

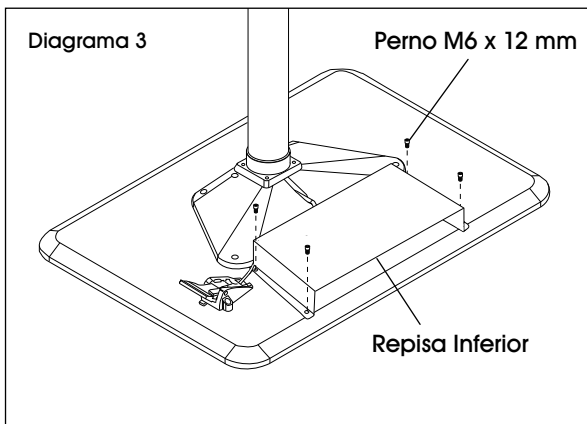

- Voltee la base al revés y colóquela en la parte inferior del poste central. Acomode los tres orificios en la parte inferior de la base con los tres orificios en el poste central. Use tres pernos M6 x 15 mm (3), tres rondanas de seguridad (5) y tres rondanas (6) para asegurar la base al poste central. Apriete por completo con la llave Allen de 5 mm. (Vea Diagrama 4)

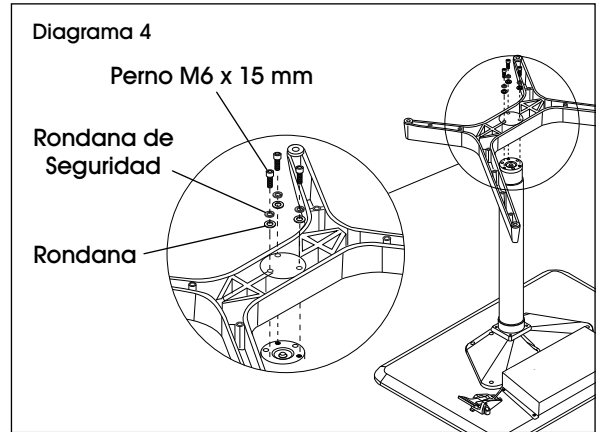

- Inserte las ruedas con seguro en las patas largas de la base e inserte las ruedas giratorias en las patas cortas de la base. (Vea Diagrama 5)

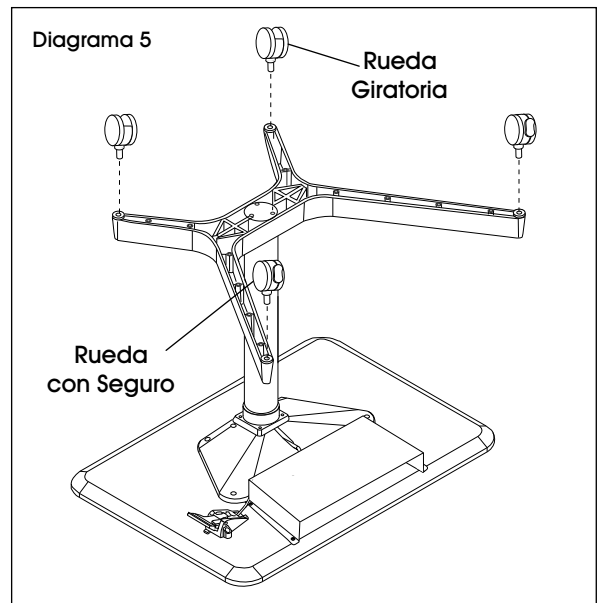

- El escritorio ahora está completamente ensamblado. Entre dos personas, volteen el escritorio con cuidado sobre las patas.

ULINE

800-295-5510
uline.mx

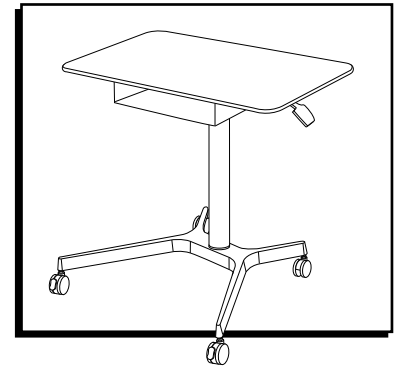
**OUTILS REQUIS**

Clé Allen de 5 mm
Clé Allen de 6 mm
(inclus)

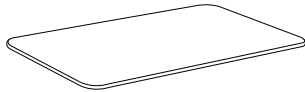
PIÈCES

Surface de table x 1

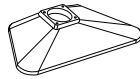

Plaque de fixation en plastique x 1

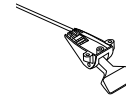

Levier de réglage de la hauteur x 1



Roulette pivotante x 2

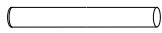

Montant central x 1

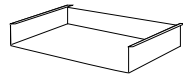

Tablette inférieure x 1

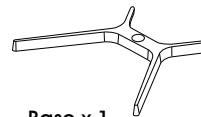

Base x 1



Roulette blocable x 2

Ensemble du matériel

1
Boulon
M8 x 15 mm x 42
Boulon
M6 x 20 mm x 73
Boulon
M6 x 15 mm x 64
Boulon
M6 x 12 mm x 45
Rondelle de
blocage x 36
Rondelle x 3**MONTAGE**

REMARQUE : Comptez et vérifiez toutes les pièces avant de jeter le matériel d'emballage ou le carton.

1. Insérez quatre boulons M8 x 15 mm (1) dans la plaque de fixation pour la rattacher au montant central. Vissez-les à l'aide d'une clé Allen de 6 mm. (Voir Figure 1)

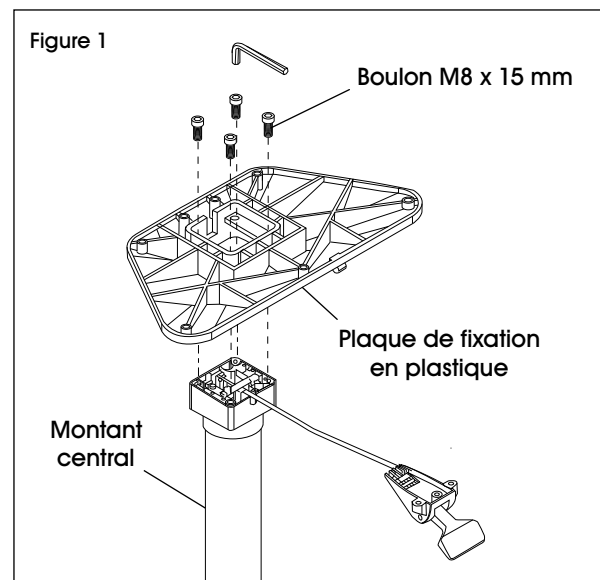

MONTAGE SUITE

- Placez la surface de table à l'envers sur une surface plane et non marquante pour que les trous prépercés soient orientés vers le haut. Alignez les trous de la plaque de fixation sur les trous prépercés de la surface de table et insérez sept boulons M6 x 20 mm (2). Insérez trois boulons M6 x 15 mm (3) sur la partie inférieure de la surface de table pour fixer le levier de réglage. (Voir Figure 2)

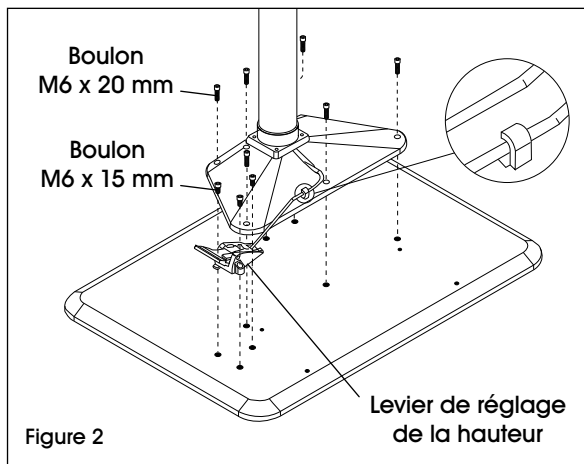

- Alignez les trous de la tablette inférieure sur les trous prépercés de la surface de table et insérez quatre boulons M6 x 12 mm (4). Le rebord sur la tablette indique le côté arrière de la tablette. (Voir Figure 3)

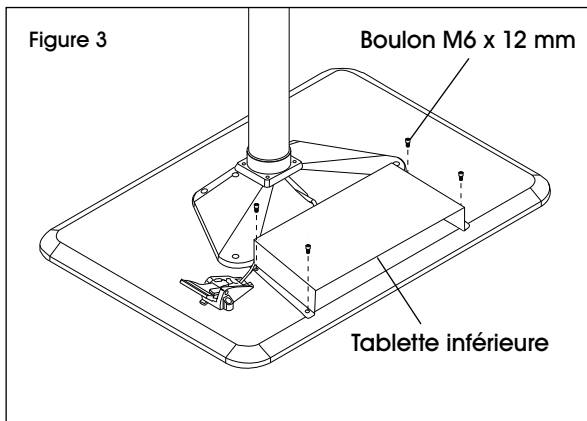

- Tournez la base à l'envers et placez-la au bout du montant central. Alignez les trois trous sous la base sur les trois trous du montant. Utilisez trois boulons M6 x 15 mm (3), trois rondelles de blocage (5) et trois rondelles (6) pour fixer la base au montant central. Vissez fermement à l'aide de la clé Allen de 5 mm. (Voir Figure 4)

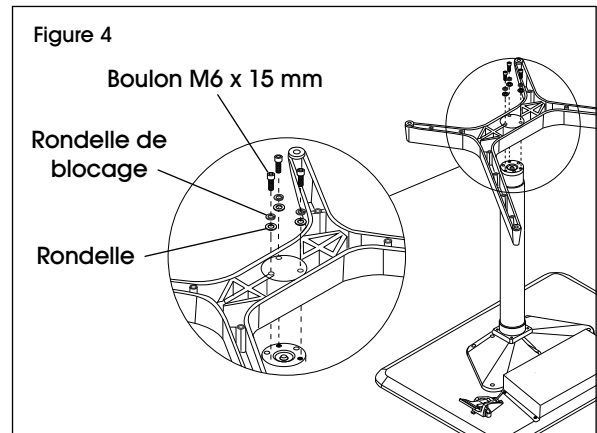

- Insérez les roulettes blocables dans les longs pieds de la base, puis insérez les roulettes pivotantes dans les courts pieds de la base. (Voir Figure 5).

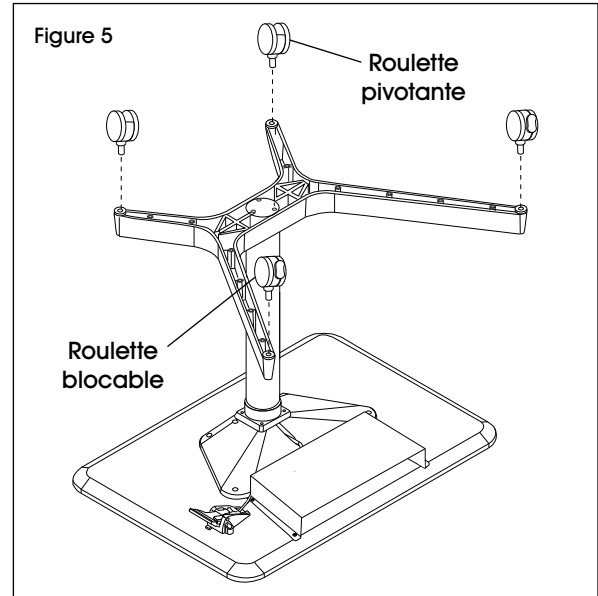

- Le montage du bureau est maintenant complété. À deux, placez le bureau avec soin sur ses roulettes.

ULINE

1-800-295-5510
uline.ca