

ULINE

DELUXE CAFE TABLE

1-800-295-5510
uline.com

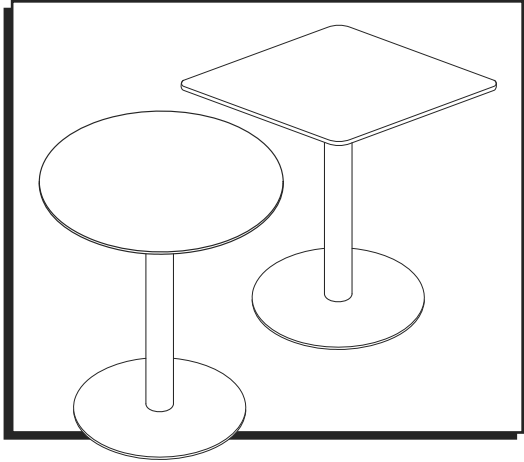

TOOLS NEEDED



5 mm Allen Wrench
4 mm Allen Wrench
(included)



Two Person Assembly
Recommended

PARTS

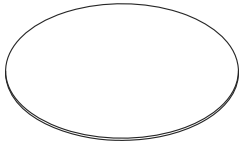

Round Tabletop x 1

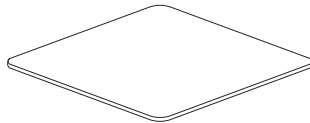

OR Square Tabletop x 1

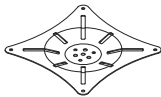

Top Plate x 1

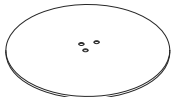

Base x 1



Column x 1

Hardware Kit

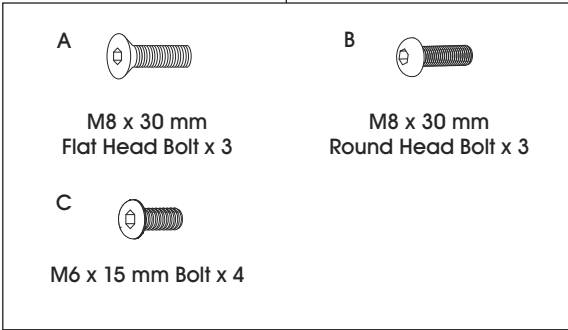

ASSEMBLY



NOTE: Assemble unit on a smooth, non-marring surface to prevent scratching.

- Check that all parts are included.
- Instructions are identical for tables with square tops and tables with round tops.

1. Connect base to column using three M8 x 30 mm flat head bolts (A). Tighten using 5 mm Allen wrench. (See Figure 1)



NOTE: Top plate and base can be attached to either end of column.

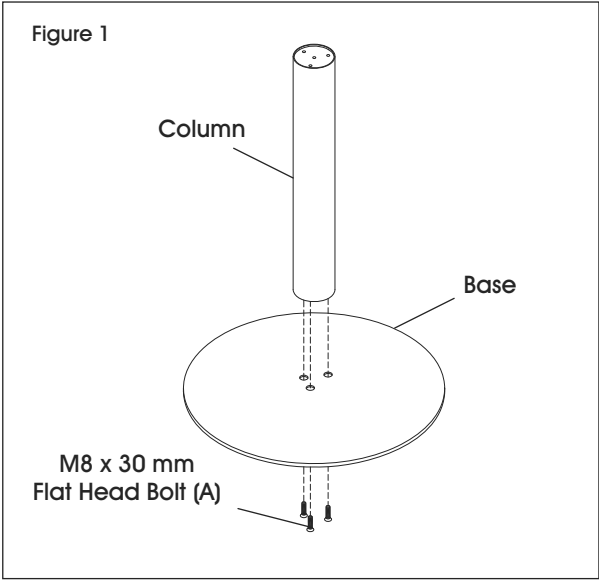

ASSEMBLY CONTINUED

2. Connect top plate to column using three M8 x 30 mm round head bolts (B). Tighten using 5 mm Allen wrench. (See Figure 2)

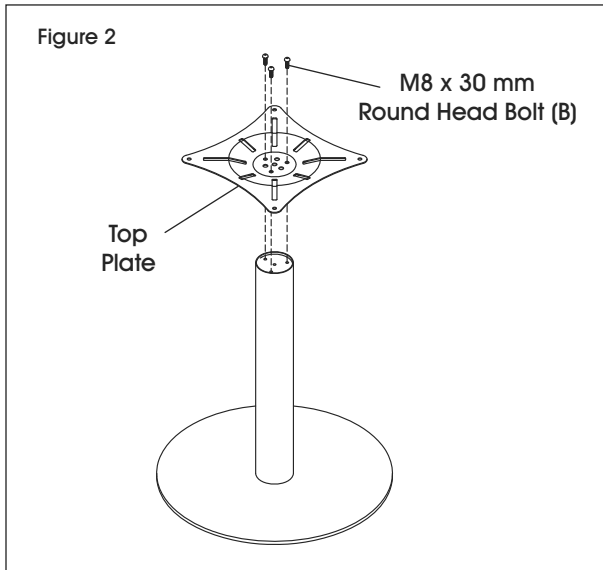

4. Café table is now fully assembled. Carefully flip the table onto base.

Completed Assembly

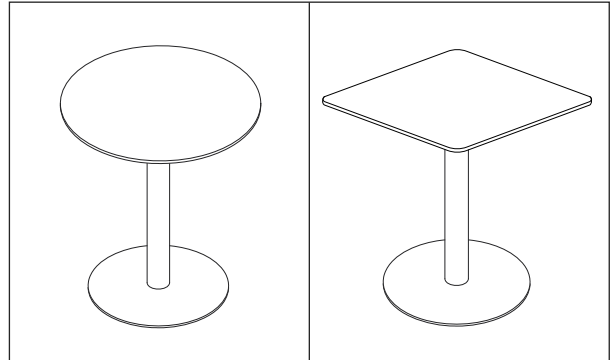

3. Align holes of top plate with holes on tabletop. Attach using four M6 x 15 mm bolts (C). Tighten using 4 mm Allen wrench. (See Figure 3)

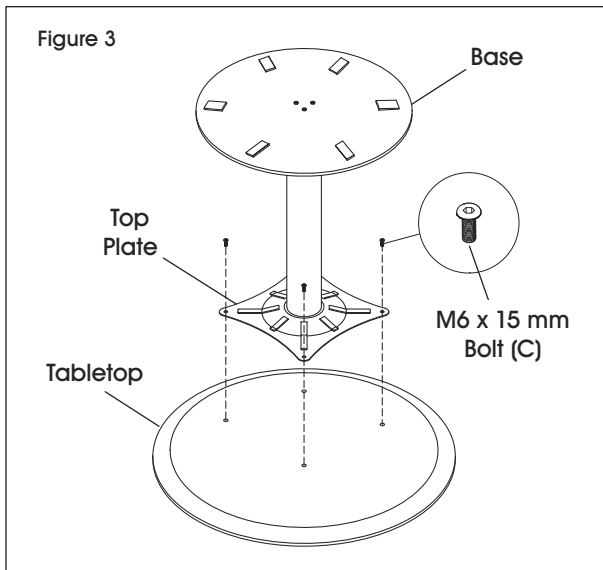

ULINE

MESA DE ALTA CALIDAD PARA CAFETERÍAS

800-295-5510

uline.mx

HERRAMIENTAS NECESARIAS



Llave Allen de 5 mm
Llave Allen de 4 mm
(incluidas)



Se recomienda Armar
Entre Dos Personas

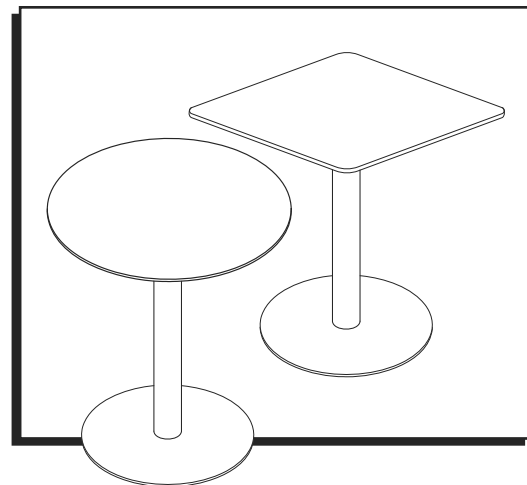

PARTES

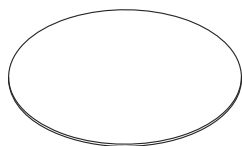

1 Cubierta Redonda

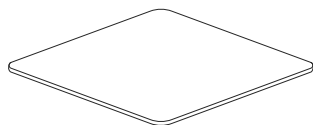

1 Cubierta Cuadrada



1 Placa Superior



1 Base



1 Columna

Kit de Tornillería



A
3 Pernos de Cabeza
Plana M8 x 30 mm



B
3 Pernos de Cabeza
Redonda M8 x 30 mm



C
4 Pernos
M6 x 15 mm

ENSAMBLE



NOTA: Ensamble la unidad sobre una superficie lisa que no deje marcas, para evitar rayones.

- Verifique que todas las partes estén incluidas.
- Las instrucciones son idénticas para las mesas de cubiertas cuadrada o redonda.

1. Conecte la base a la columna utilizando tres pernos de cabeza plana M8 x 30 mm (A). Apriete utilizando una llave Allen de 5 mm. (Vea Diagrama 1)



NOTA: La placa superior y la base se pueden fijar a cualquier extremo de la columna.

Diagrama 1

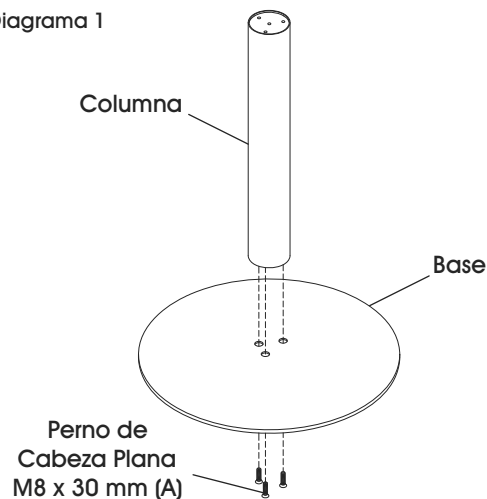

CONTINUACIÓN DEL ENSAMBLE

- Conecte la placa superior a la columna utilizando tres pernos de cabeza redonda M8 x 30 mm (B). Apriete con la llave Allen de 5 mm. (Vea Diagrama 2)

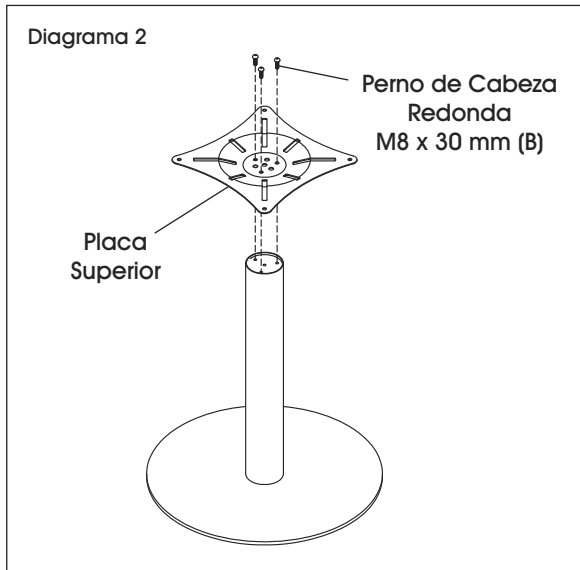

- Terminó el ensamble de la mesa para cafetería. Voltéela sobre la base.

Ensamble Terminado

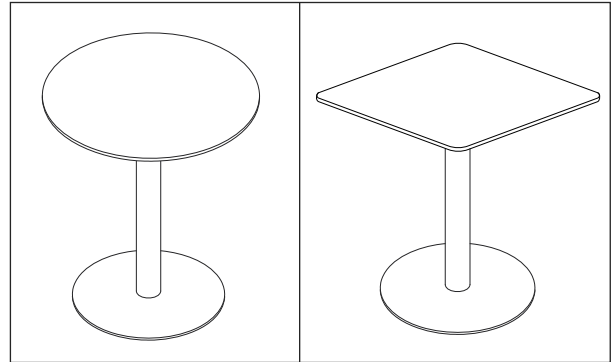

- Alinee los orificios de la placa superior con los orificios en la cubierta. Fije utilizando cuatro pernos M6 x 15 mm (C). Apriete con la llave Allen de 4 mm. (Vea Diagrama 3)

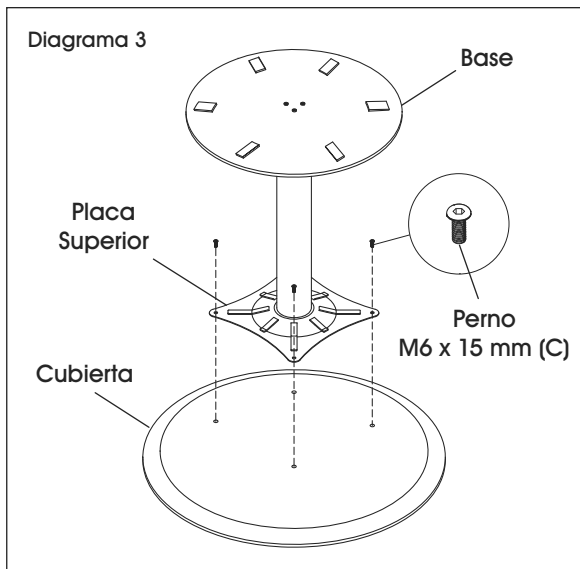

OUTILS REQUIS

Clé Allen de 5 mm
Clé Allen de 4 mm
(inclus)

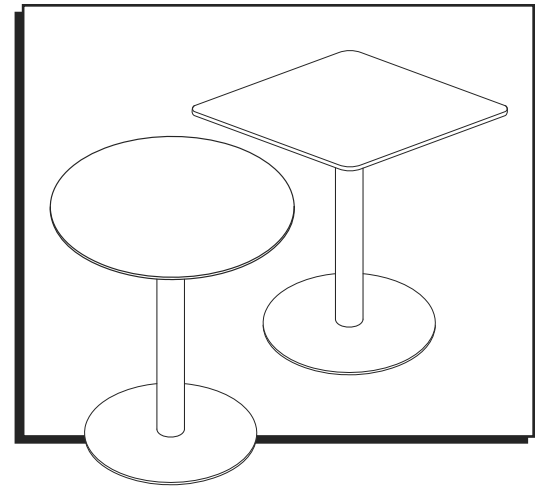
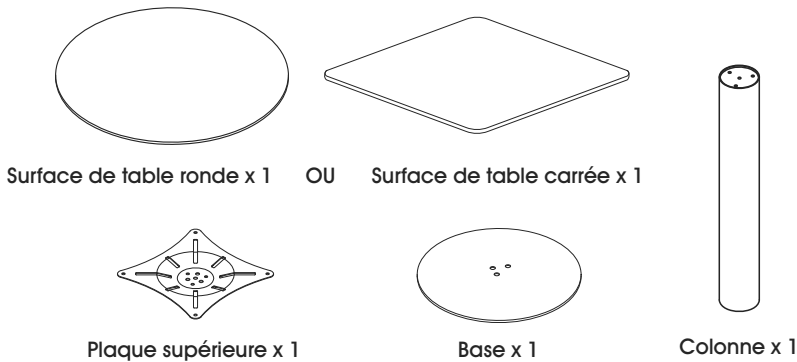

Montage à deux
personnes recommandé

**PIÈCES**

Matériel de fixation

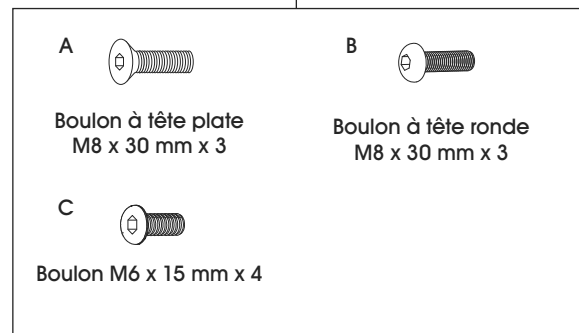
**MONTAGE**

REMARQUE : Montez le meuble sur une surface lisse qui ne marque pas afin d'éviter les rayures.

- Vérifiez que toutes les pièces sont incluses.
- Les instructions sont identiques pour les tables carrées et les tables rondes.

1. Connectez la base à la colonne à l'aide de trois boulons à tête plate M8 x 30 mm (A). Serrez le tout à l'aide de la clé Allen de 5 mm. (Voir Figure 1)



REMARQUE : La plaque supérieure et la base peuvent être attachées indifféremment de chaque côté de la colonne.

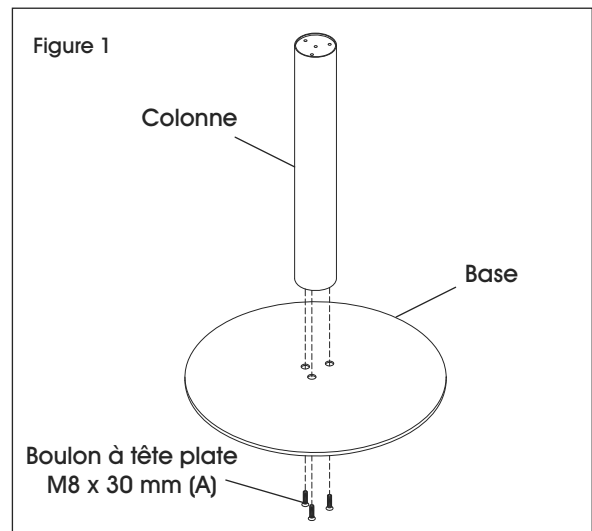

MONTAGE SUITE

- Fixez la plaque supérieure à la colonne à l'aide de trois boulons à tête ronde M8 x 30 mm (B). Serrez le tout à l'aide de la clé Allen de 5 mm. (Voir Figure 2)

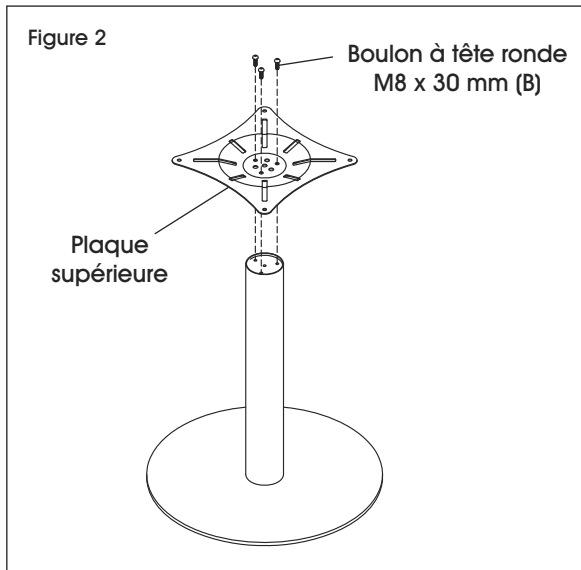

- Le montage de la table à café est maintenant complété. Remettez avec soin la table à l'endroit.

Montage complété

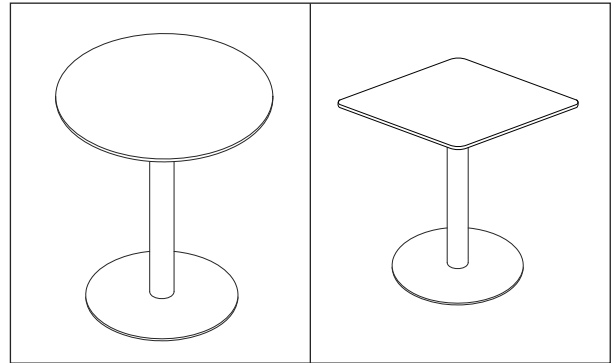

- Alignez les trous de la plaque supérieure sur ceux de la surface de table. Fixez-les avec quatre boulons M6 x 15 mm (C). Serrez le tout à l'aide de la clé Allen de 4 mm. (Voir Figure 3)

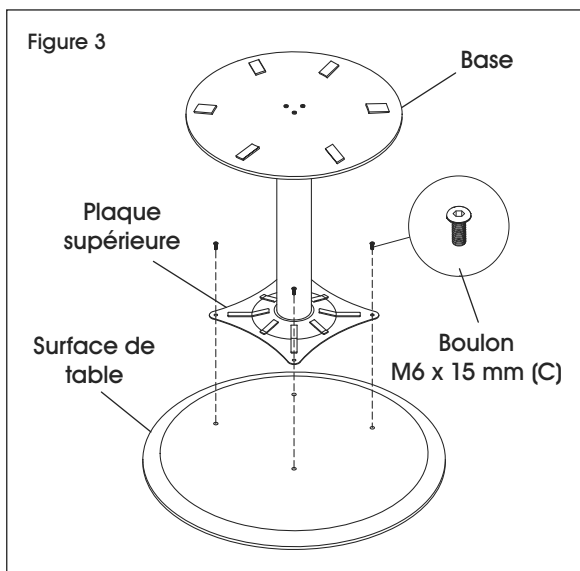

ULINE

1-800-295-5510
uline.ca