

ULINE H-9236, H-9248

20 x 40' EVENT TENT

1-800-295-5510
uline.com

TOOLS NEEDED



Sledge Hammer
(for H-9236)

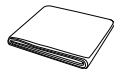

Drop Cloth
(recommended)



Three Person Assembly
Recommended

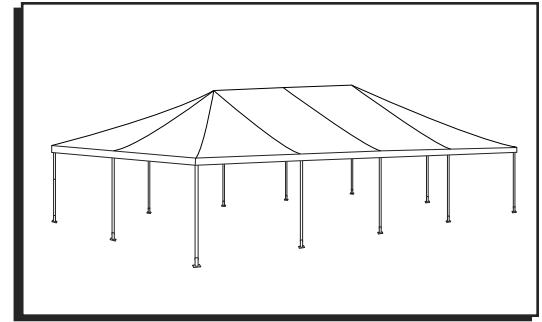

PARTS

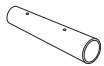

Pole

6'8" Leg (LG) – Black x 12
9'4" Eave (EV) – White x 12
9'4" Ridge (RG) – White x 2
10'6" Full Rafter (FR) – Green x 8
14'4" Hip Rafter (HR) – Red x 4

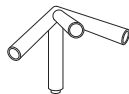

Corner x 4

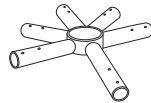

6-Way Crown x 2



Ridge Crown x 1

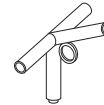

4-Way Side Tee x 8



2" Ratchet
Strap x 12



Base Plate x 12



Bail Pin x 76

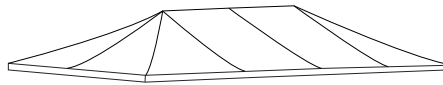

Canopy Top x 1



Steel Stake x 12
(for H-9236)



Barrel x 12
(for H-9248)

Barrel Hardware Kit



Bail Pin x 12

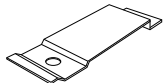

Mounting Plate x 12



3/8" Flat Washer x 12



5/8" Flat Washer x 24



3/8" Hex Nut x 12

SAFETY



IMPORTANT! Please read carefully.

- Keep away from all flame and heat sources.
- Do not cook underneath or near canopy.
- Do not store or use flammable liquids underneath or near canopy.
- Do not ignite or store fireworks underneath or near canopy.
- Do not use bleach to clean cover.
- Do not dry clean cover.

- Do not wash cover in washing machine or dry in dryer. Hand wash with mild soap and water only.
- Do not hang or suspend anything from the frame, grommets or truss system of the unit.
- Do not allow rain water, snow or ice to accumulate on top of cover.
- Remove rain water, snow and ice from canopy cover.



NOTE: This is a temporary structure and is not recommended for use as a permanent structure.

ASSEMBLY



IMPORTANT! Before setting up tent, contact Diggers Hotline (8-1-1) or a local authority to verify that it is safe to set up tent in desired location. Be aware of weather conditions, and always evacuate tent during periods of high winds or lightning.

1. Ensure all parts are present before assembly. Lay frame parts on ground in approximate locations they will be when frame is assembled. (See Figure 1)

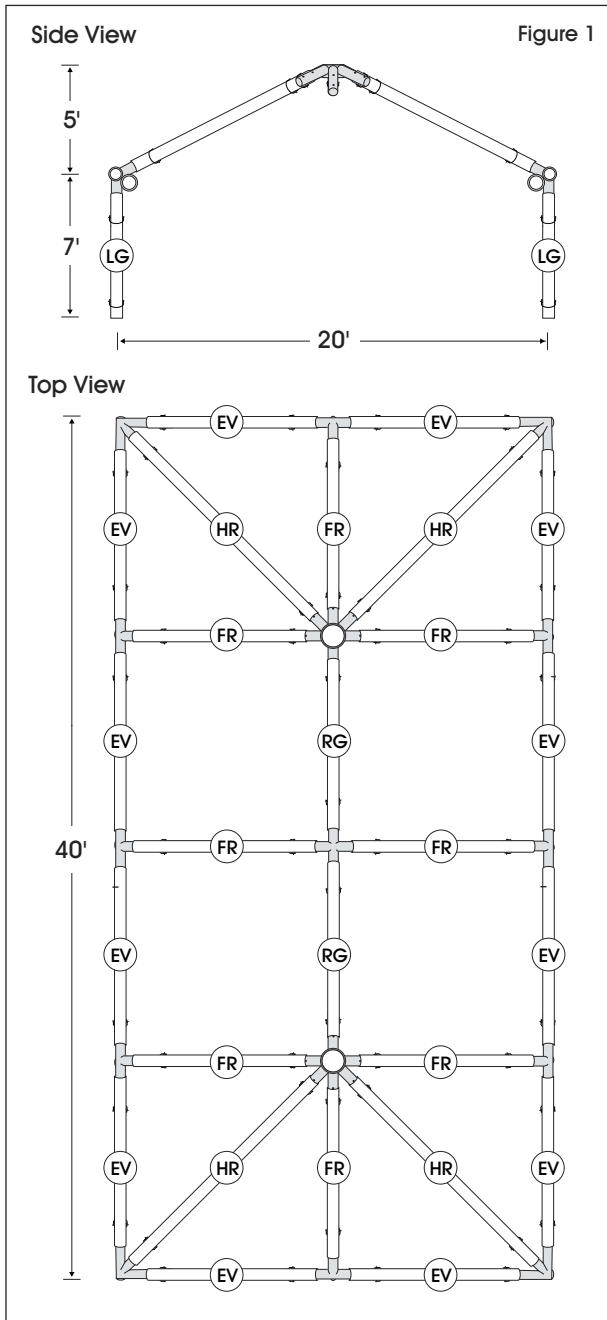

2. Place frame pins in 6-way crown.
 - a. Each protrusion on crown has two holes. The alignment hole is closer to the center; the placement hole is further down the protrusion. (See Figure 2)

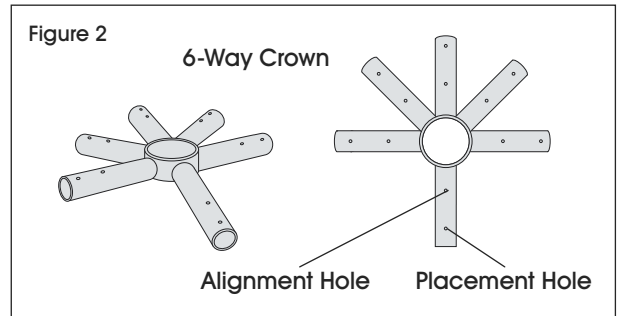

- b. Place a bail pin in each alignment hole. Bail pin prevents rafter from moving too far onto 6-way crown. (See Figure 3)

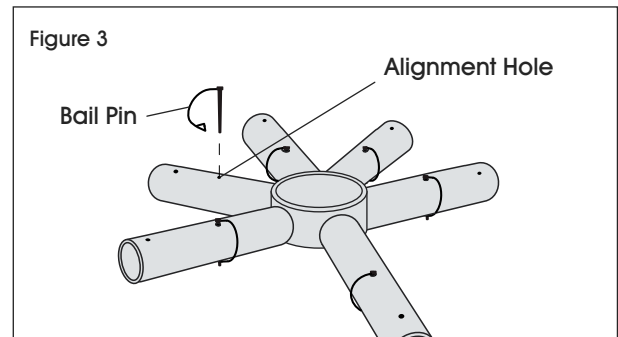

3. Align two hip rafters (HR) with 6-way crown. (See Figure 4)

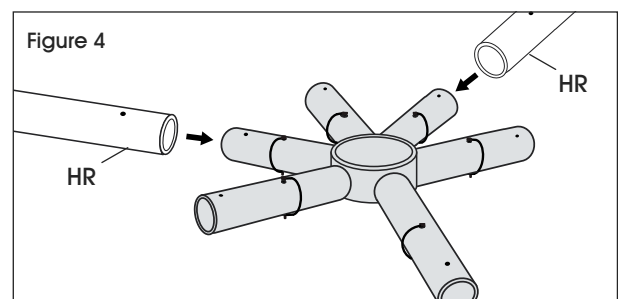

ASSEMBLY CONTINUED

- a. Slide hip rafters (HR) onto protrusion until they meet pin. (See Figure 5)

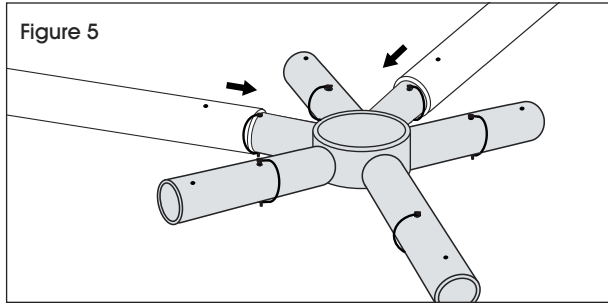

- b. Align placement hole in the crown with hole in rafter and insert bail pin. (See Figure 6)

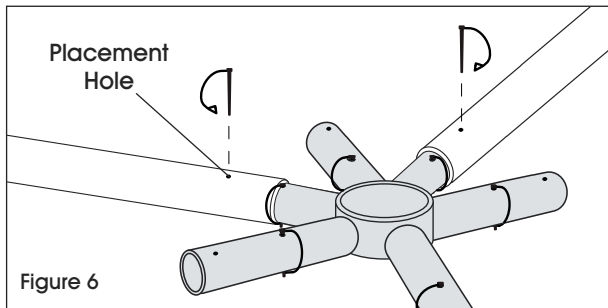

- c. Remove alignment hole pins where hip rafters (HR) are attached to crown. (See Figure 7)

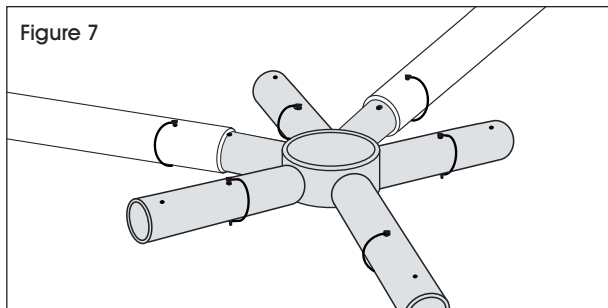

4. Repeat steps 3b-3c to connect three full rafters (FR) to the 6-way crown. (See Figure 8)

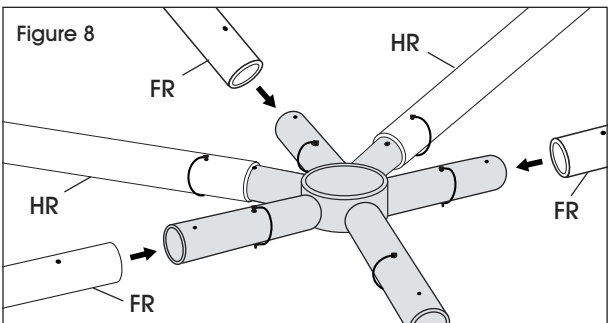

5. Beginning at a corner fitting, attach eave poles (EV) to corner fittings and 4-way side tee fittings, working clockwise around the assembly to complete the first end bay. Attach to hip rafters (HR) and full rafters (FR). (See Figures 9-10)

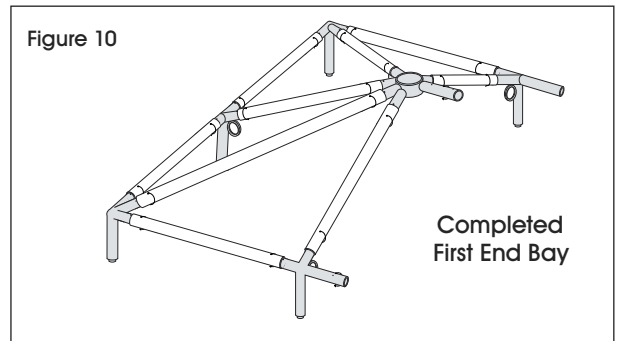
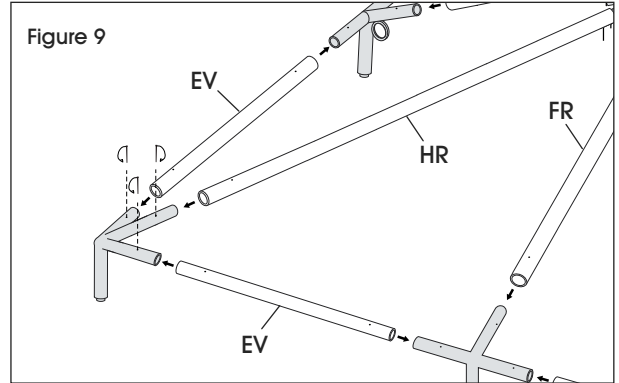

6. Repeat steps 2-5 to complete second end bay. (See Figure 11)

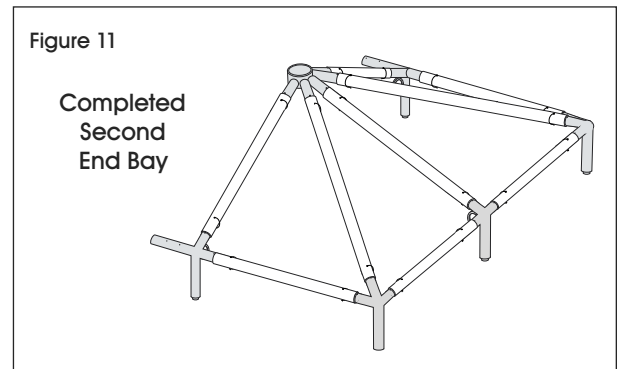

ASSEMBLY CONTINUED

7. Connect ridge crown and two full rafters (FR) to two 4-way side tees to create center frame. Secure with bail pins. (See Figure 12)

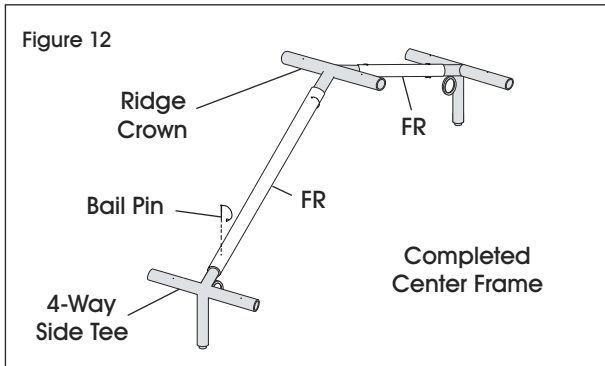

8. Attach end bays to center frame with two ridge poles (RG) and four eave poles (EV). Secure with frame pins. (See Figure 13)

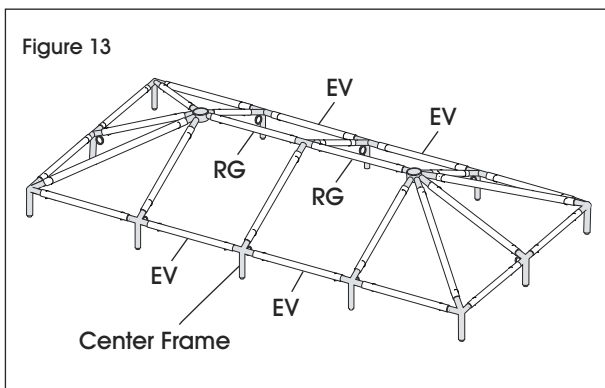

9. Loop end of each ratchet strap to fitting at each leg location. (See Figure 14)

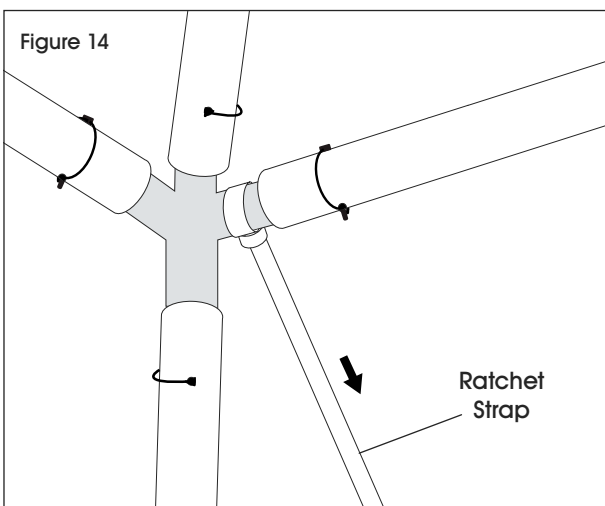

10. Unroll the tent top. (See Figures 15-16)

 **NOTE:** It is recommended to place tent top on a drop cloth to protect from dirt and abrasions.

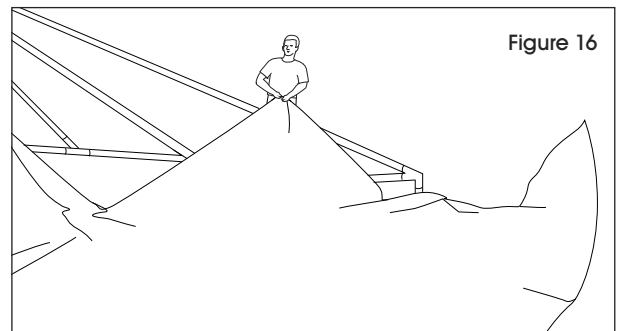
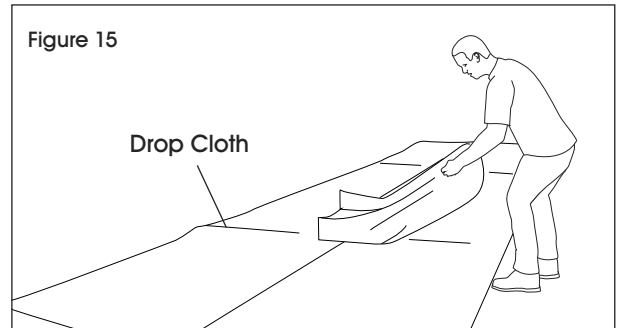

11. Pull tent top over frame, lifting up on fabric to create air cushion under tent top. (See Figure 17)

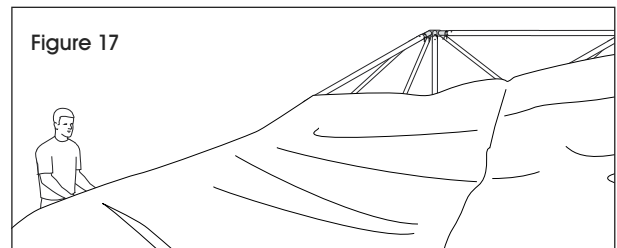

12. Center tent top on frame by aligning the seams with hip rafters (HR). (See Figure 18)

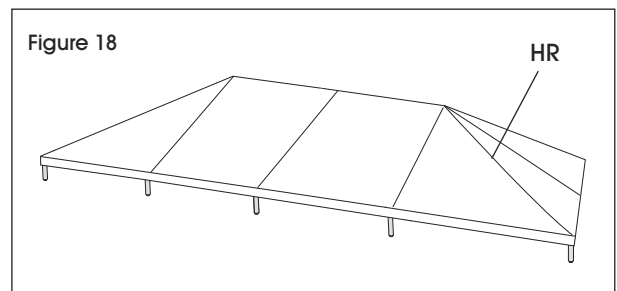

ASSEMBLY CONTINUED

- Loosely fasten the alligator straps and attach to canopy top at each side of the corners around eave poles (EV) to secure tent top. (See Figure 19)

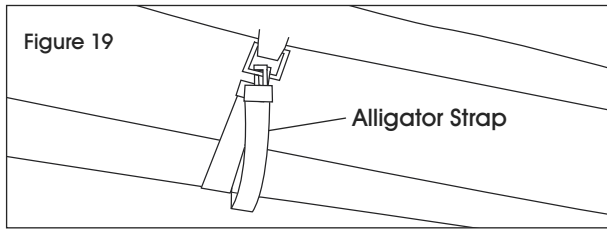

- Attach base plates to legs and secure with bail pin. (See Figure 20)

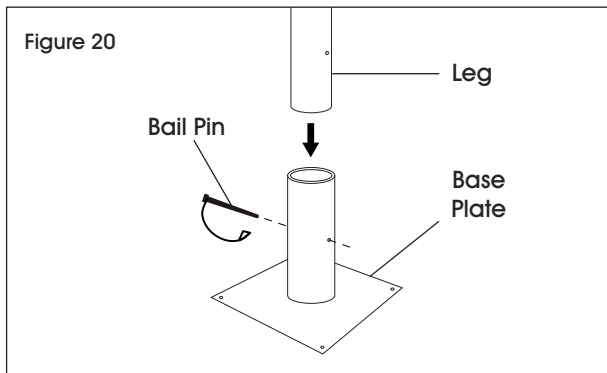

- Lift downwind side of frame and keep all sides level. Attach leg poles to the lifted side. (See Figure 21)

 **NOTE:** Always lift the downwind side of tent first.

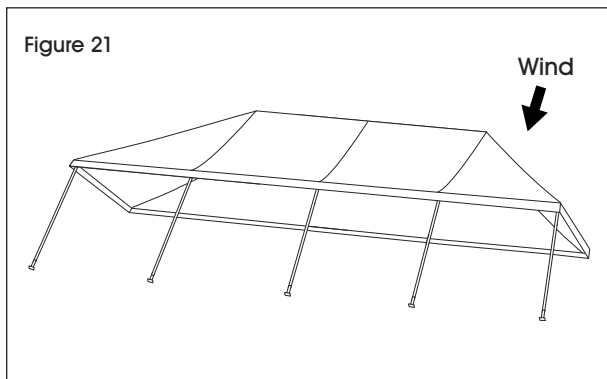

- Raise other side of tent and attach remaining legs. (See Figure 22)

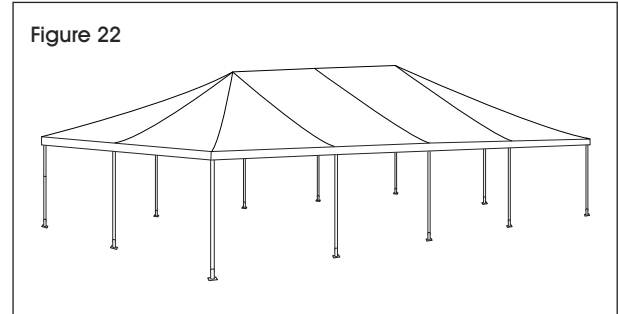

- Fasten the rest of the alligator straps around eave poles (EV) by tugging on the excess strap to keep the material taut and pulling the straps firmly. Slide excess strap through the metal slide on the alligator clip. (See Figure 23)

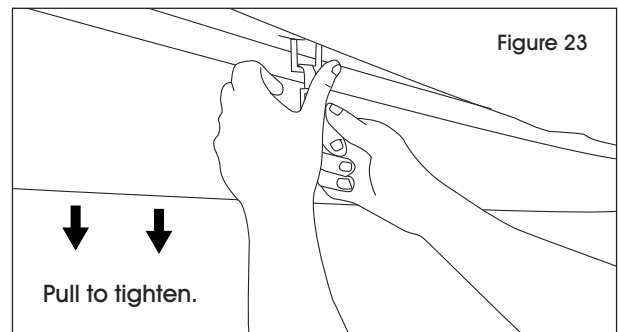

CAUTION! Yanking on straps will cause undue wear and tear as well as wrinkling of tent top fabric.

IF USING STAKES (H-9236)

- Place stakes 5' out from each leg. Drive stakes into the ground until 6" or less of the stake shows. (See Figure 24)

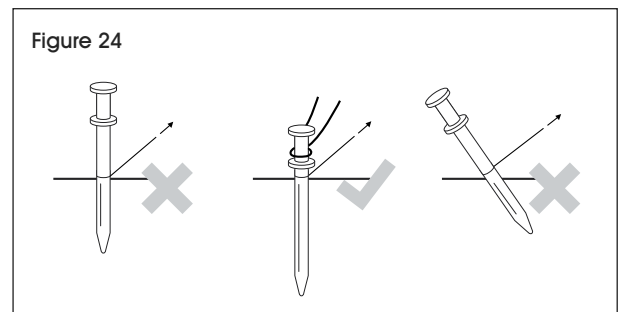

ASSEMBLY CONTINUED

2. Attach ratchet straps to the stakes loosely. (See Figure 25)
 - a. Attach ratchet buckle with loop strap to stakes by turning the 6" loop at the end of the ratchet inside out and pulling strap through the loop.
 - b. Pull slipknot tight over stake.
 - c. Take loop strap attached to tent and pull it through reel bars slot of ratchet.

 **NOTE: Keep ratchet buckle handle facing up at all times.**

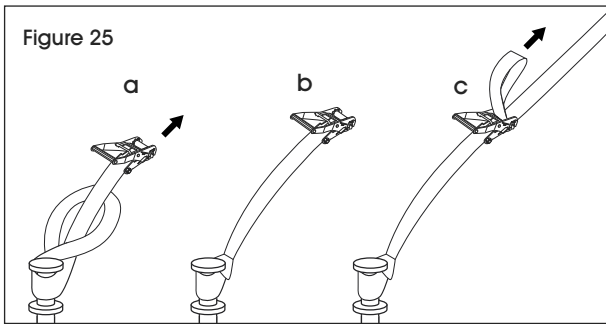

3. Tighten ratchet straps by holding strap and pulling all slack through ratchet reel. Pull all slack through ratchet reel, holding strap with one hand and cranking ratchet handle with the other.

4. Roll excess ratchet straps and secure into the ratchet buckle. (See Figure 26)

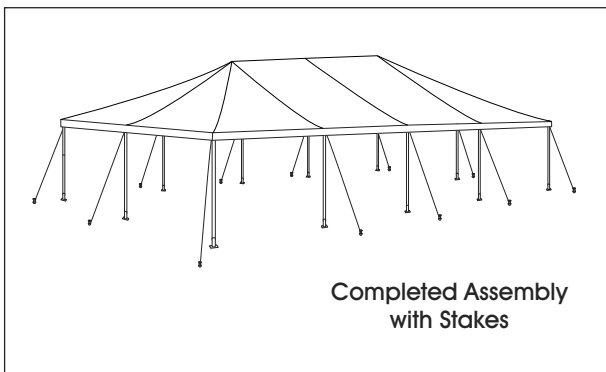
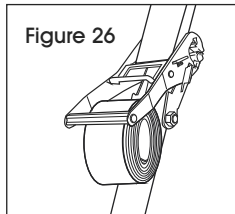

IF USING BARRELS (H-9248)

1. Turn the barrel upside down to connect the mounting plate. (See Figure 27)

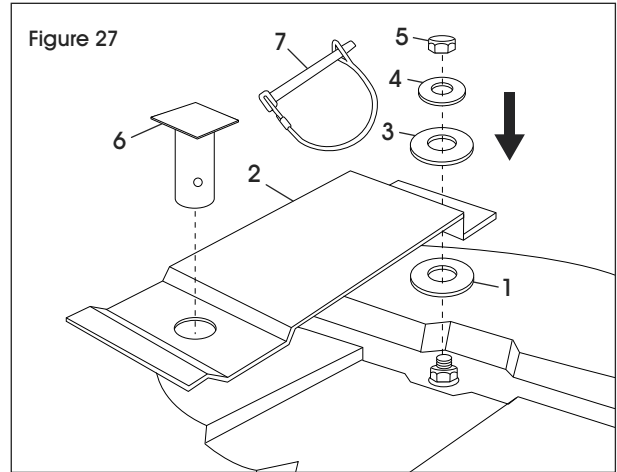

- a. Put a 5/8" washer (1) over the nut and bolt.
 - b. Place the mounting plate (2) over the washer.
 - c. Place another 5/8" washer (3) followed by a 3/8" washer (4).
 - d. Place and tighten the 3/8" nut (5).
 - e. Flip the barrel right-side up and insert the base plate (6) through the hole in the plate.
2. Place a pole over the base plate that has been inserted into the plate. Put bail pin (7) through pole and base plate to secure. (See Figure 28)

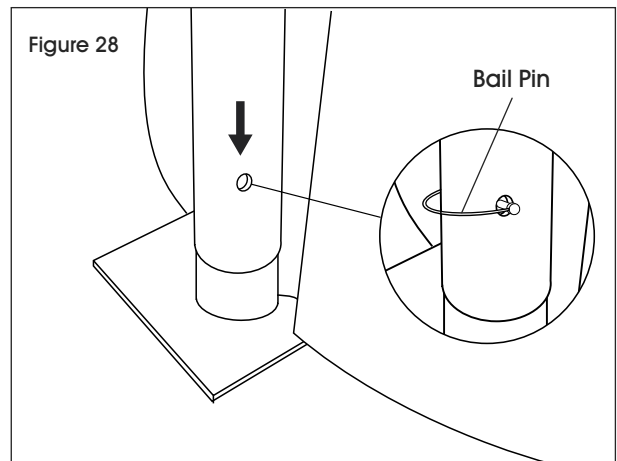

ASSEMBLY CONTINUED



NOTE: Attach strap at bottom of barrel before filling barrel with water. (See Figure 29)

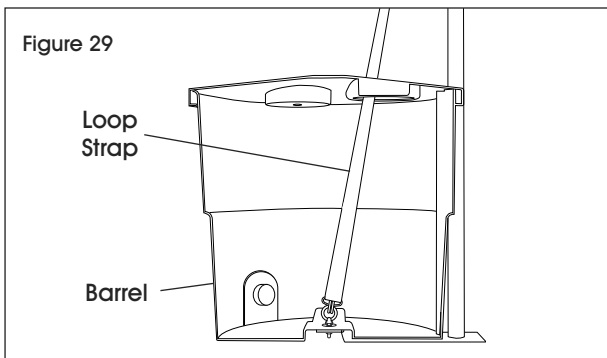

3. To connect the strap to eye bolt in bottom of barrel, pull looped strap through the eye bolt. Take the other end of strap and pull it all the way through the loop. Pull long end tight to secure strap to eye bolt. (See Figure 30)

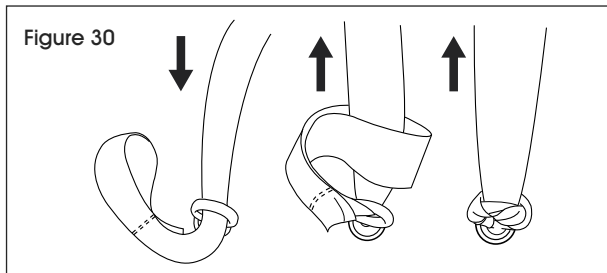

4. Pull strap through cover slit. (See Figure 31)

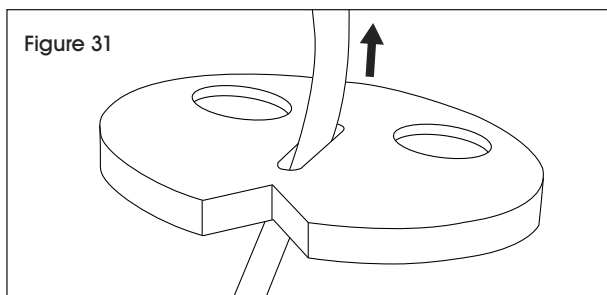

5. Connect the opposite end of the strap to the fitting at the top of the pole, not around the tent frame poles. This forms a strong triangle. (See Figure 32)

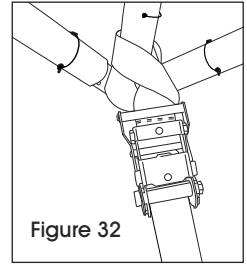

6. Fill barrel with water.



NOTE: Keep ratchet buckle handle facing up at all times.

7. After barrel is full, tighten ratchet straps by pulling all slack through ratchet reel, holding strap with one hand while cranking ratchet handle with the other.

8. Roll excess ratchet straps and secure into the ratchet buckle. (See Figure 33)

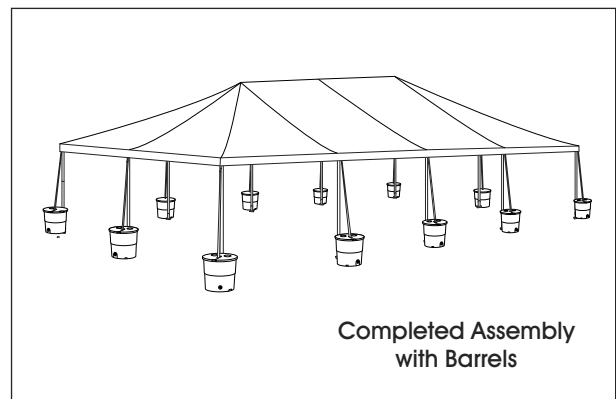
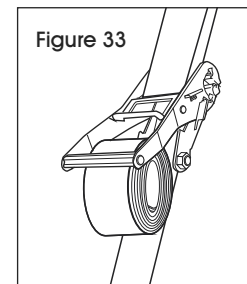

TAKING DOWN TENT



Three Person Takedown
Recommended

1. Loosen ratchet strap assemblies and remove straps from stakes or barrels.



NOTE: If using barrels, drain them. Lift every leg and remove pin from barrel, setting legs on ground not back on barrel. Move the barrels away from tent to make room for lowering tent.

2. Remove three center legs on long side and two adjacent side legs. (See Figure 34)

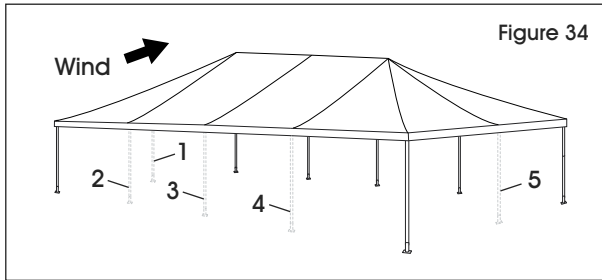

3. Unfasten all alligator straps except the two at each corner (one at each side of corner). (See Figure 35)

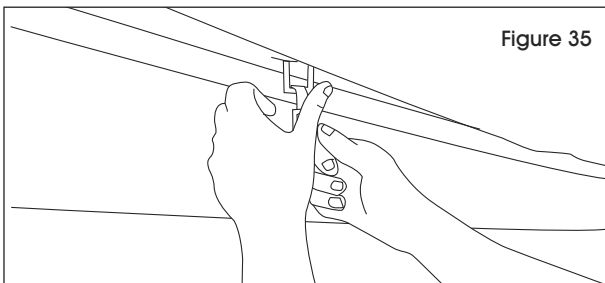

4. Start with upwind side. Have another person remove two corner legs from one side and carefully set tent frame on the ground. (See Figures 36-38)

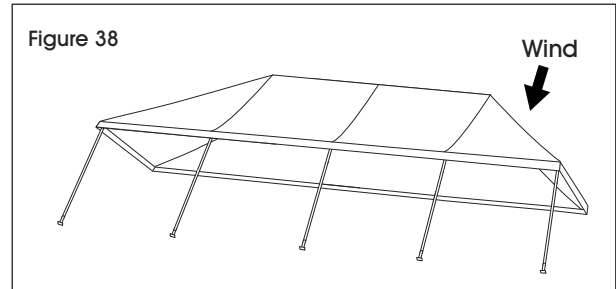
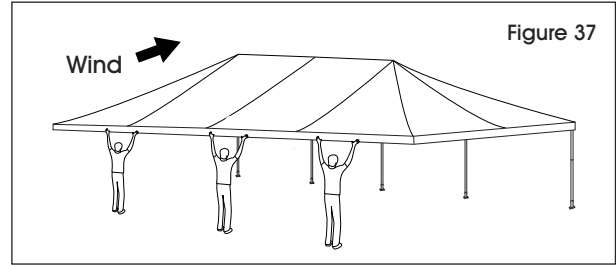
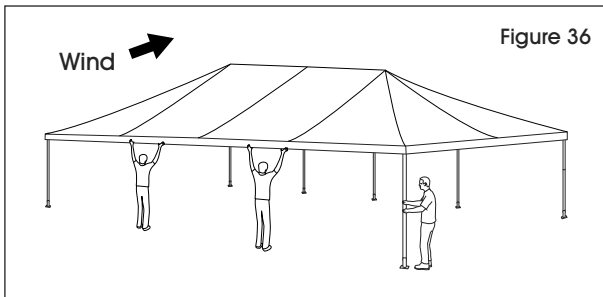

5. Remove remaining legs. (See Figure 39)

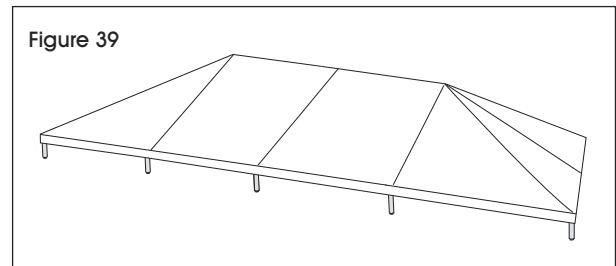

6. Unfasten remaining straps until all are completely disconnected.
7. Remove the tent top from the frame.
8. Fold and roll the tent top pieces as tightly as possible. Use a fanfold or a z-fold for best results.



NOTE: For longevity of the tent, do not stand or walk on top of the tent top. It is recommended to dry and wipe the tent top fabric clean before folding for storage.

9. Disassemble all corner, side tee and center crown fittings by removing pins and sliding tubing off fittings. Work from perimeter of frame inward.
10. Remove all stakes. If using barrels, empty water for storage.

ULINE

1-800-295-5510

uline.com

ULINE H-9236, H-9248

CARPA PARA EVENTOS DE 20 x 40'

800-295-5510

uline.mx

HERRAMIENTAS NECESARIAS



Marro
(para H-9236)



Paño de Tela
(recomendado)



Se recomienda Armar
Entre Tres Personas

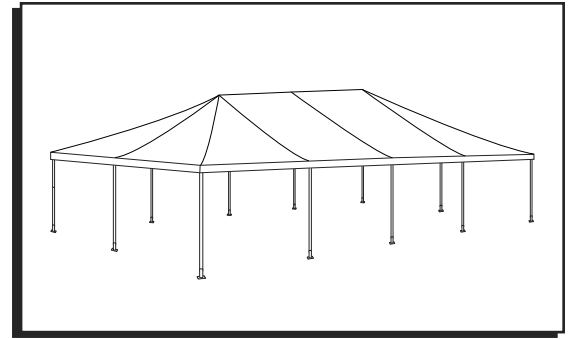

PARTES

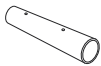

Poste

12 Patas de 6'8" (LG) – Negras
12 Aleros de 9'4" (EV) – Blancas
2 Cumbreras de 9'4" (RG) – Blancas
8 Vigas Completas de 10'6" (FR) – Verdes
4 Vigas de Limatesa de 14'4" (HR) – Rojas

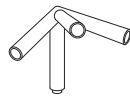

4 Esquinas

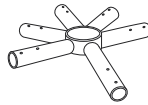

2 Coronas de
6 Entradas



1 Corona de
la Cumbreira

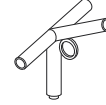

8 Uniones T Laterales
de 4 Entradas



12 Correas para
Trinquetes de 2"

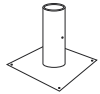

12 Placas de Base



76 Pasadores
de Grillete

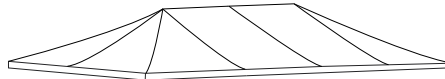

1 Cubierta para Carpa



12 Estacas de Acero
(para H-9236)



12 Tambors
(para H-9248)

Tornillería para Tambors



12 Pasadores
de Grillete

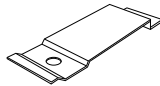

12 Placas
de Instalación



12 Rondanas Planas
de 3/8"



24 Rondanas
Planas de 5/8"



12 Tuercas
Hexagonales de 3/8"

SEGURIDAD



¡¡IMPORTANTE! Por favor lea cuidadosamente.

- Mantenga la carpa lejos de todas las llamas y fuentes de calor.
- No cocine por debajo o cerca de la carpa.
- No almacene o utilice líquidos inflamables por debajo o cerca de la carpa.
- No encienda o almacene fuegos pirotécnicos por debajo o cerca de la carpa.
- No use blanqueador para limpiar la carpa.
- No lave en seco la carpa.

- No lave la carpa en lavadora ni la seque en secadora. Lave a mano con detergente suave y agua solamente.
- No cuelgue ni suspenda nada del armazón, ojales o sistema de entramado de la unidad.
- No permita que el agua de lluvia, nieve o hielo se acumule por encima de la carpa.
- Retire agua de lluvia, nieve o hielo de la carpa.



NOTA: Esta es una estructura temporal y no se recomienda utilizarla como estructura permanente.

ENSAMBLE



¡IMPORTANTE! Antes de montar la carpa, comuníquese con Diggers Hotline 8-1-1 (EUA) o una autoridad local para verificar que sea seguro hacerlo en la ubicación deseada. Tome en cuenta las condiciones climatológicas y siempre evacúe la carpa durante periodos de vientos fuertes o relámpagos.

1. Verifique que estén todas las partes antes de comenzar. Coloque las partes del armazón sobre el suelo en la ubicación aproximada en la que estarán cuando el armazón quede ensamblado. (Vea Diagrama 1)

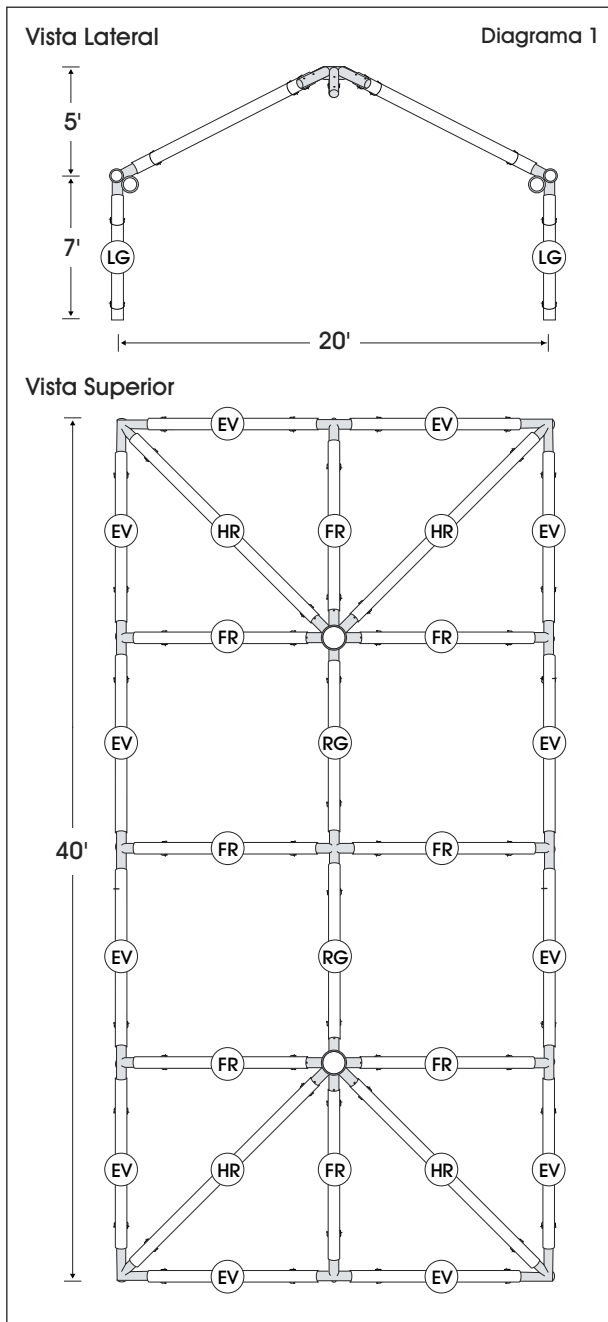

2. Coloque los pasadores de armazón en la corona de 6 entradas.
 - a. Cada saliente en la corona cuenta con dos orificios. El orificio de alineación está más cerca del centro; el de colocación está más abajo del saliente. (Vea Diagrama 2)

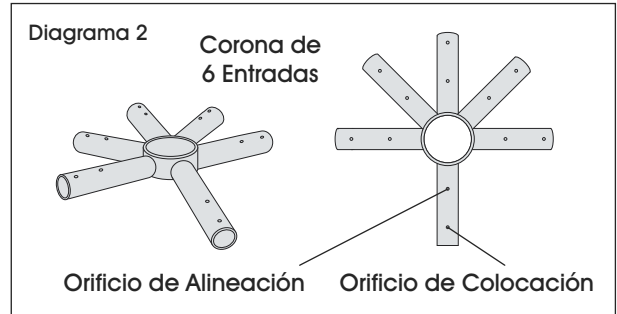

- b. Coloque un pasador de grillete en cada orificio de alineación. El pasador evita que la viga se mueva demasiado hacia el interior de la corona de 6 entradas. (Vea Diagrama 3)

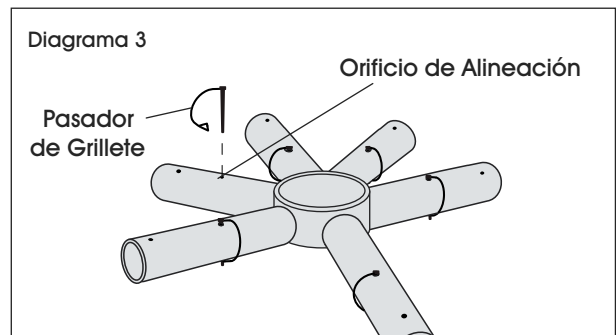

3. Alinee las dos vigas de limatesa (HR) con la corona de 6 entradas. (Vea Diagrama 4)

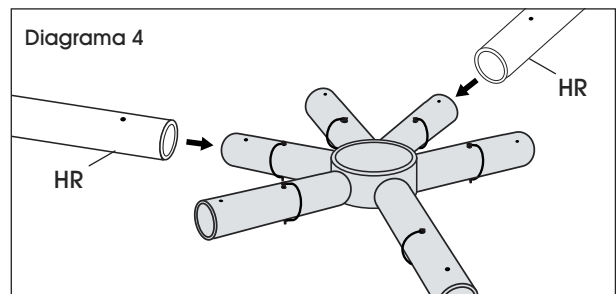

CONTINUACIÓN DEL ENSAMBLE

- a. Deslice las vigas de limatesa (HR) hacia el saliente hasta que den con el pasador. (Vea Diagrama 5)

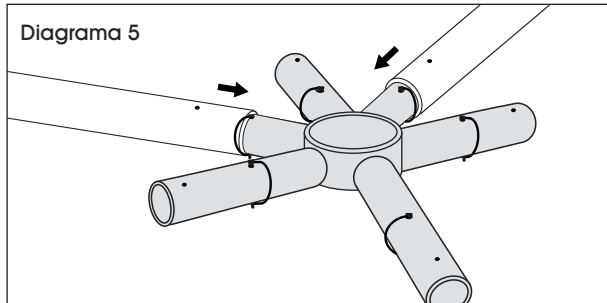

- b. Alinee el orificio de colocación de la corona con el orificio de la viga e inserte el pasador de grillete. (Vea Diagrama 6)

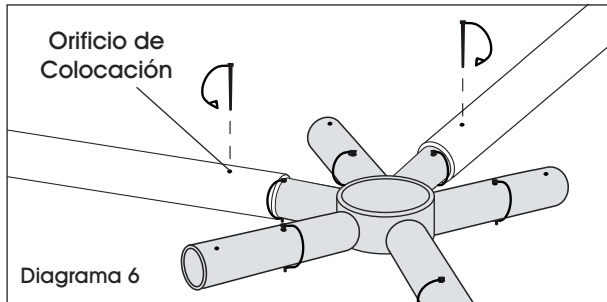

- c. Quite los pasadores de los orificios de alineación donde las vigas de limatesa (HR) se unen a la corona. (Vea Diagrama 7)

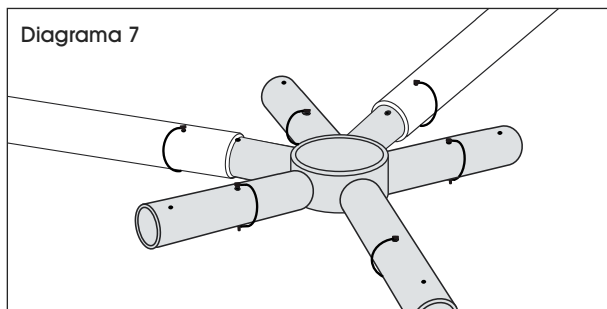

4. Repita los pasos 3b-3c para conectar las cuatro vigas completas (FR) a la corona de 6 entradas. (Vea Diagrama 8)

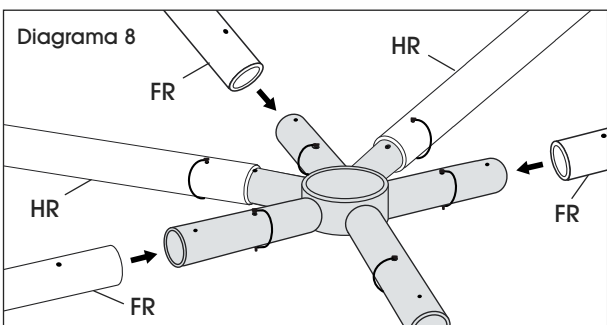

5. Comenzando con un conector de esquinas, fije los tubos del alero (EV) a los conectores de esquina y a los conectores laterales en T de 4 entradas, trabajando en el sentido de las manecillas del reloj alrededor del ensamblaje. Fije a las vigas de limatesa (HR) y las vigas completas (FR). (Vea Diagramas 9-10)

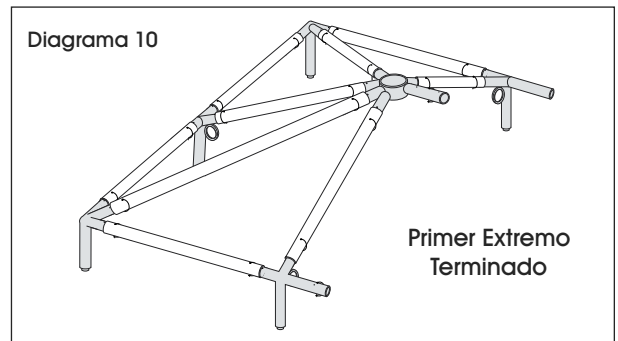
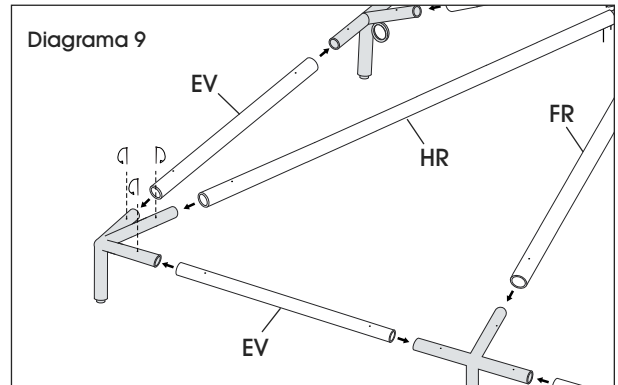

6. Repita los pasos 2-5 para completar el segundo extremo. (Vea Diagrama 11)

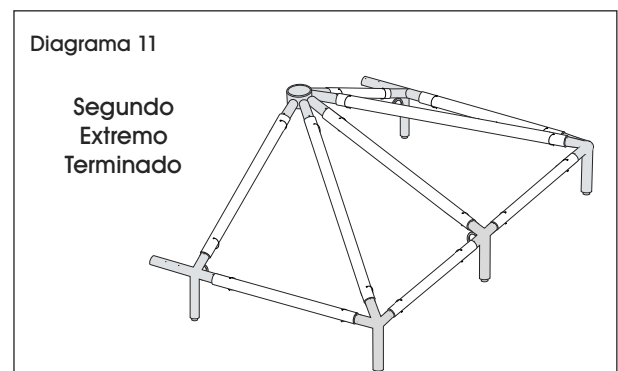

CONTINUACIÓN DEL ENSAMBLE

7. Conecte la corona de la cumbre y dos vigas completas (FR) a dos conectores laterales en T para crear el armazón central. Asegure con pasadores de grillete. (Vea Diagrama 12)

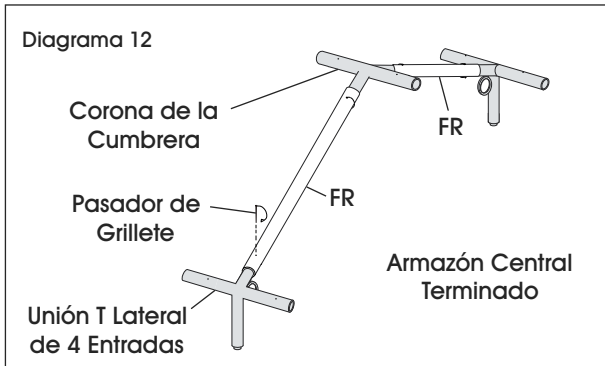

8. Una los extremos al armazón central con dos tubos de cumbre (RG) y cuatro tubos de alero (EV) Asegure con pasadores de armazón. (Vea Diagrama 13)

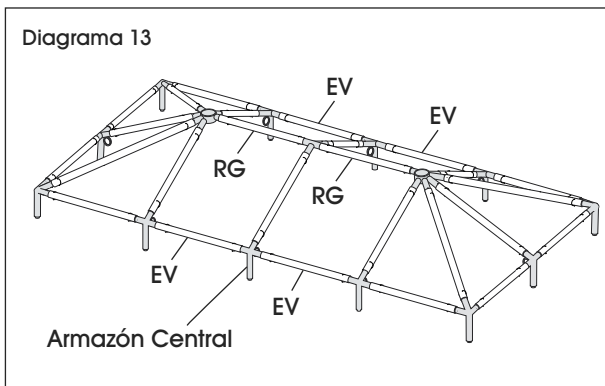

9. Enlace el extremo de cada correa para trinquete al conector en la ubicación de cada pata. (Vea Diagrama 14)

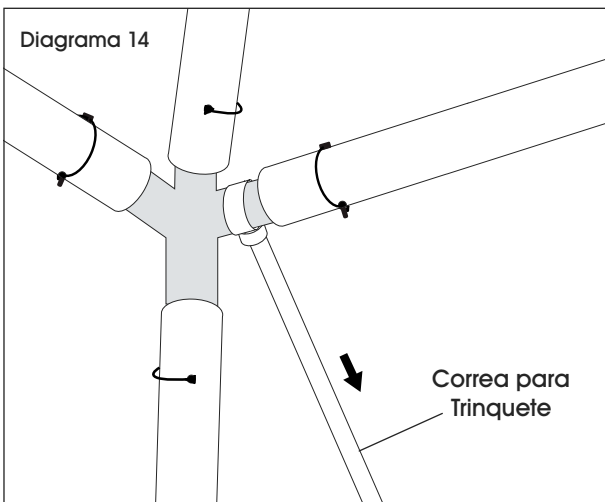

10. Desenrolle la cubierta de la carpa. (Vea Diagramas 15-16)



NOTA: Se recomienda colocar la cubierta de la carpa sobre un paño de tela para protegerla de la suciedad y las abrasiones.

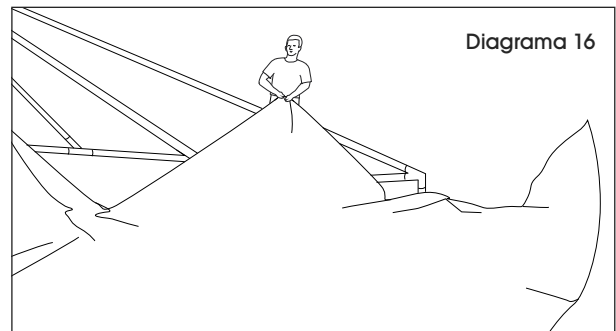

11. Jale la cubierta de la carpa sobre el armazón y levante la tela para crear una cámara de aire debajo de la cubierta. (Vea Diagrama 17)

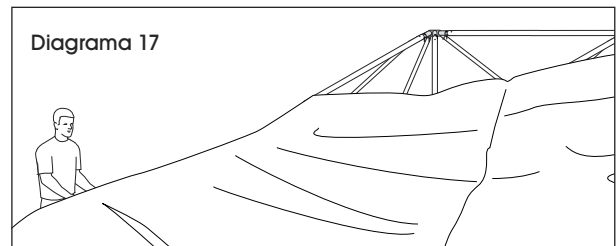

12. Centre la cubierta de la carpa sobre el armazón alineando las costuras con las vigas de limatesa (HR). (Vea Diagrama 18)

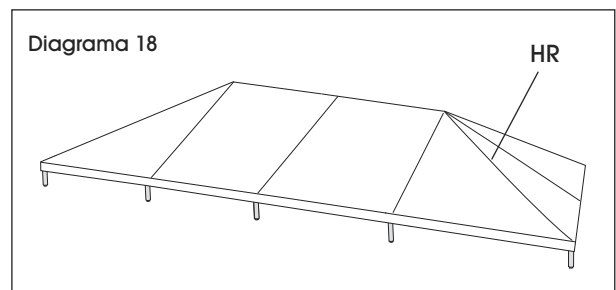

CONTINUACIÓN DEL ENSAMBLE

13. Para asegurar la parte superior de la carpa, sujete (sin apretar) las correas con pinzas a la parte superior de la carpa a cada lado de las esquinas alrededor de los tubos EV. (Vea Diagrama 19)

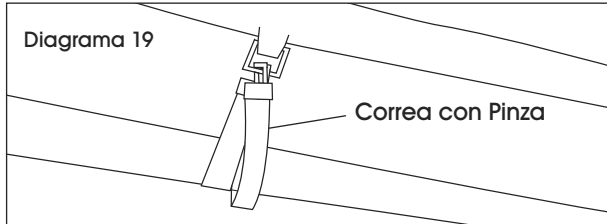

14. Fije las placas de bases a las patas y asegúrelas con un pasador de grillete. (Vea Diagrama 20)

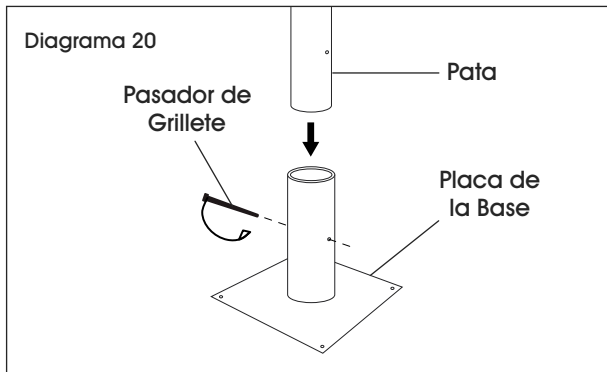

15. Levante el lateral del armazón en dirección del viento y mantenga todos los laterales nivelados. Fije los postes de las patas al lado levantado. (Vea Diagrama 21)

 **NOTA:** Levante siempre primero el lateral de la carpa en dirección del viento.

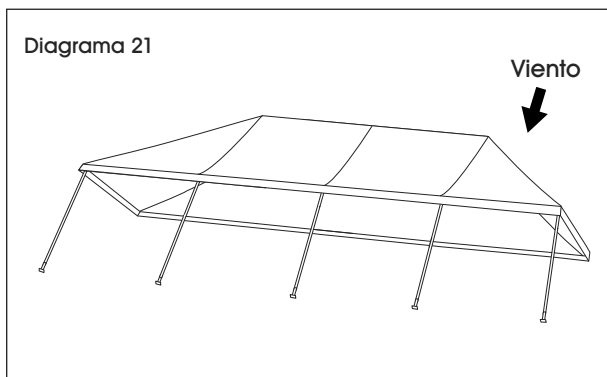

16. Levante el otro lateral de la carpa y fije las patas restantes. (Vea Diagrama 22)

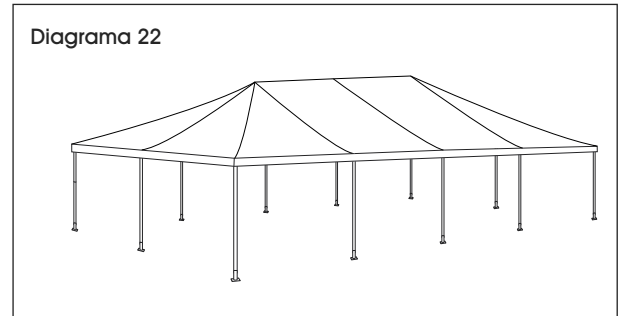

17. Ajuste el resto de las correas con pinzas alrededor de los tubos EV tirando de la cenefa para mantener el material tenso y jalando firmemente las correas. Deslice la correa sobrante a través de la hebilla de metal en el clip con pinza. (Vea Diagrama 23)

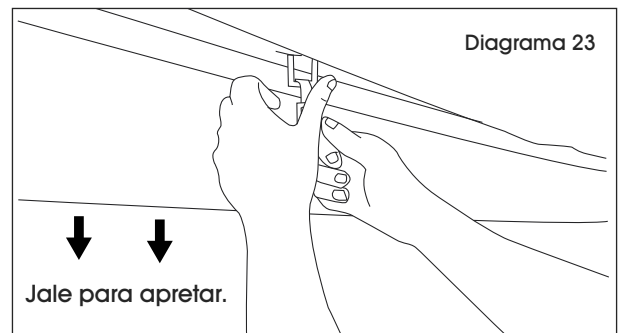

¡PRECAUCIÓN! Jalar las correas muy fuerte causará un desgaste innecesario y también arrugará la tela de la cubierta de la carpa.

SI USA ESTACAS (H-9236)

1. Coloque las estacas a 1.5 m (5') de cada pata. Clave las estacas al suelo hasta que queden visibles 15 cm (6") o menos de la estaca. (Vea Diagrama 24)

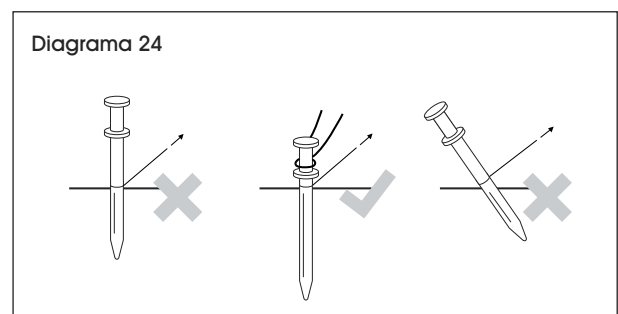

CONTINUACIÓN DEL ENSAMBLE

2. Fije las correas para trinquete sin apretar. (Vea Diagrama 25)
 - a. Fije la hebilla del trinquete con los lazos de las correas a las estacas volteando el lazo de 15 cm (6") en el extremo del trinquete al revés y jalando la correa a través del lazo.
 - b. Jale firmemente el lazo corredizo sobre la estaca.
 - c. Tome el lazo de la correa sujeta a la carpa y jálalo a través de la ranura de los soportes de carrete del trinquete.

 **NOTA:** Mantenga el asa de la hebilla del trinquete hacia arriba en todo momento.

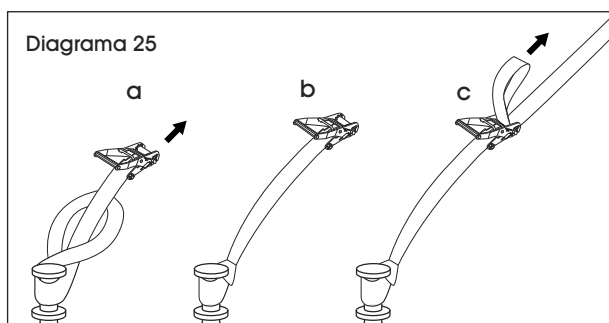

3. Apriete las correas para trinquete sosteniendo la correa y jale lo que resta a través del carrete del trinquete. Sostenga la correa con una mano y el asa del trinquete con la otra.
4. Enrolle el excedente de las correas para trinquete y asegúrelas en la hebilla del trinquete. (Vea Diagrama 26)

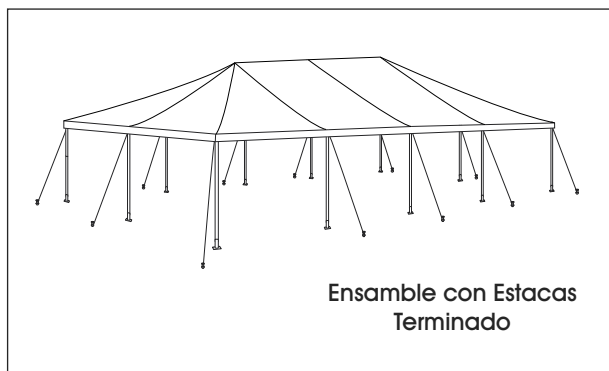
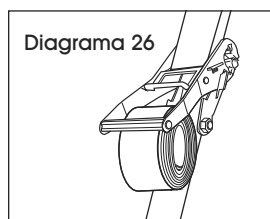

SI USA TAMBOS (H-9248)

1. Voltee el tambo al revés para conectar la placa de instalación. (Vea Diagrama 27)

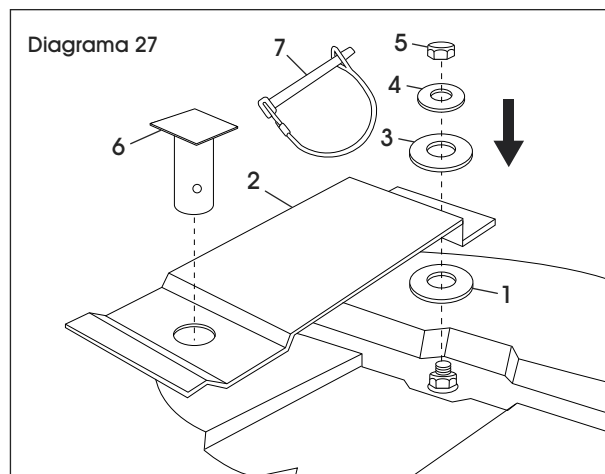

- a. Coloque una rondana de 5/8" (1) sobre la tuerca y el perno.
 - b. Coloque la placa de instalación (2) sobre la rondana.
 - c. Coloque otra rondana de 5/8" (3) seguida por una de 3/8" (4).
 - d. Coloque y apriete la tuerca de 3/8" (5).
 - e. Enderece el tambo e inserte la placa de base (6) por el orificio en la placa.
2. Coloque un poste sobre la placa de base que se insertó en la placa. Inserte el pasador de grillete (7) por el poste y la placa de base para fijarlos. (Vea Diagrama 28)

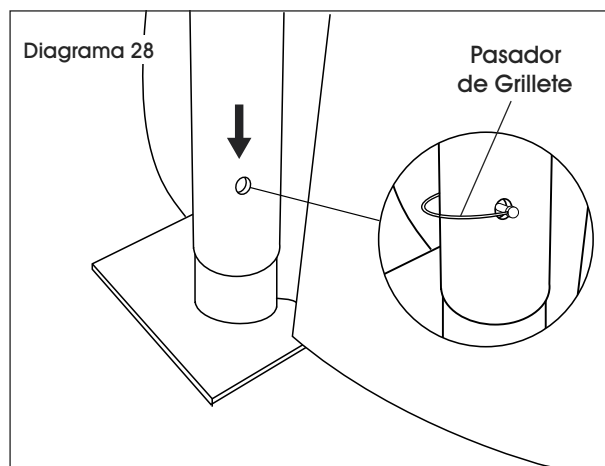

CONTINUACIÓN DEL ENSAMBLE



NOTA: Fije la correa en la parte inferior del tambo antes de llenar el tambo con agua. (Vea Diagrama 29)

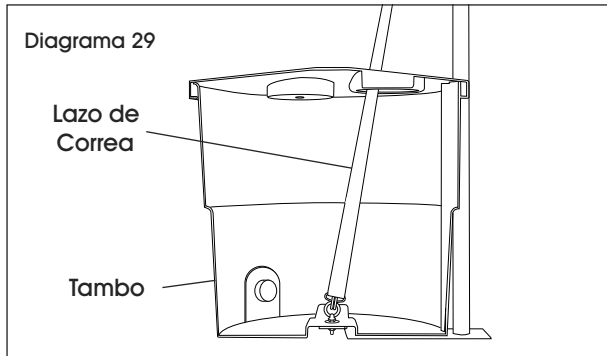

3. Para conectar la correa a la armella en la parte inferior del tambo, jale el lazo de la correa a través de la armella. Tome el otro extremo de la correa y júlela completamente a través del lazo. Jale firmemente el extremo largo para asegurar la correa a la armella. (Vea Diagrama 30)

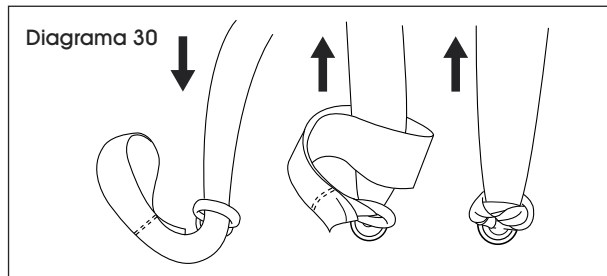

4. Jale la correa a través de la ranura de la cubierta del tambo. (Vea Diagrama 31)

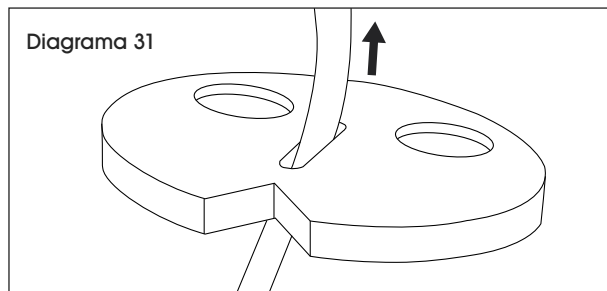

5. Una el extremo opuesto de la correa al conector en la parte posterior del poste, no lo haga alrededor del armazón de los postes de la carpa. Esto forma un triángulo resistente. (Vea Diagrama 32)

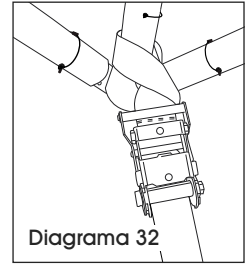

6. Llene el tambo con agua.



NOTA: Mantenga el asa de la hebilla del trinquete hacia arriba en todo momento.

7. Después de que el tambo quede lleno, jale las correas para trinquete jalando lo que resta a través del carrete del trinquete sosteniendo la correa con una mano y girando el asa del trinquete con la otra.
8. Enrolle el excedente de las correas para trinquete y asegúrelas en la hebilla del trinquete. (Vea Diagrama 33)

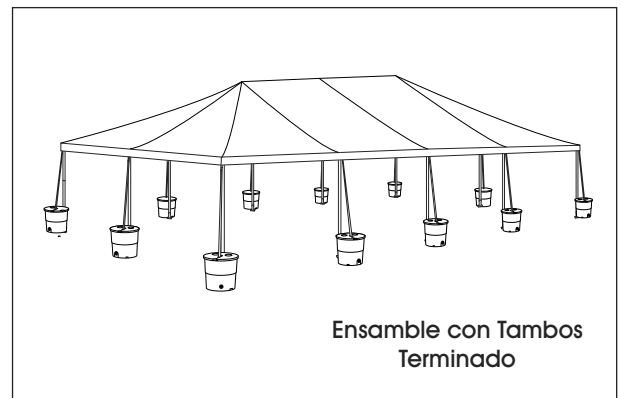
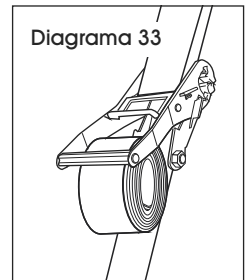

DESMONTAR LA CARPA



Se Recomienda Desmontar
Entre Tres Personas

1. Suelte los ensambles de correas para trinquete y retire las correas de las estacas o tambos.



NOTA: Si utiliza tambos, drénelos. Levante todas las patas y retire el pasador del tambo. Coloque las patas en el suelo, no de nuevo en el tambo. Aleje los tambos de la carpa para hacer espacio y bajarla.

2. Retire tres patas centrales del lateral largo y dos patas laterales adyacentes. (Vea Diagrama 34)

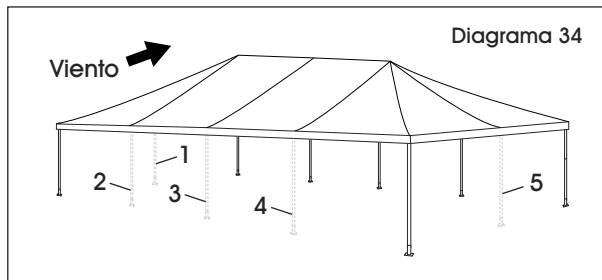

3. Desate todas las correas con pinza excepto las dos en cada esquina (una en cada lado de la esquina). (Vea Diagrama 35)

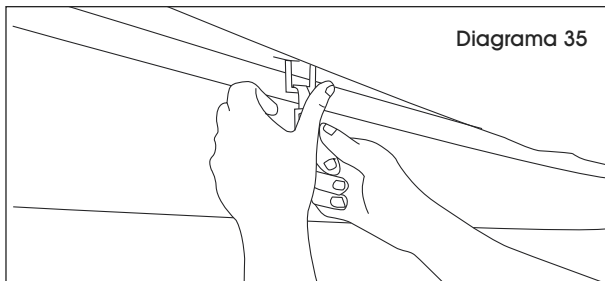

4. Comience con el lado en dirección del viento. Pídale a otra persona que retire dos patas de las esquinas de un lado y que coloque con cuidado el armazón de la carpa en el suelo. (Vea Diagramas 36-38)

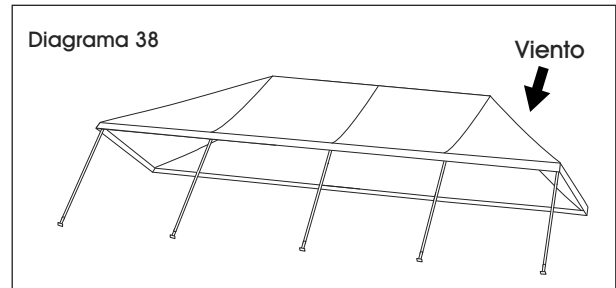
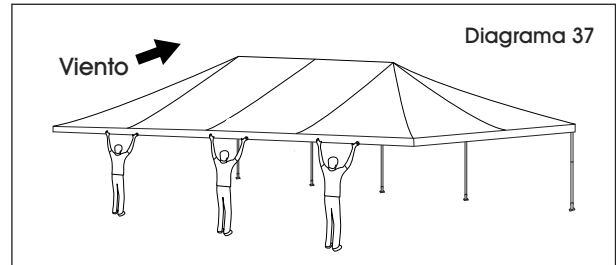
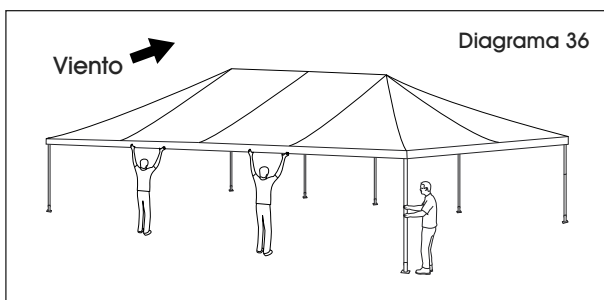

5. Retire las patas restantes. (Vea Diagrama 39)

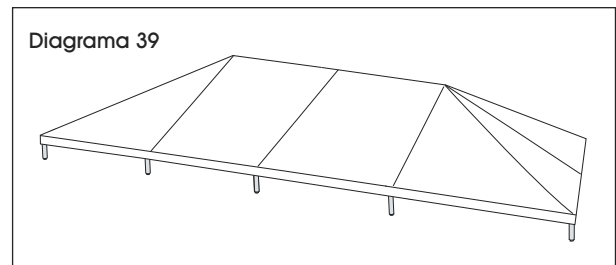

6. Desate el resto de las correas hasta que todas queden desconectadas por completo.
7. Retire la cubierta de la carpa del armazón.
8. Doble y enrolle las piezas de la cubierta de la carpa lo más ajustado posible. Doble en abanico o en Z para mejores resultados.



NOTA: Para la durabilidad de la carpa, no se pare o camine sobre la cubierta de esta. Se recomienda secar y limpiar la tela de la carpa con una toalla antes de doblarla para almacenarla.

9. Desarme todos los conectores de esquina, laterales en T y la corona central retirando los pasadores y sacando los tubos de los conectores. Trabaje del perímetro del armazón hacia adentro.
10. Retire todas las estacas. Si usa tambos, vacíe el agua para almacenarlos.

ULINE

800-295-5510

uline.mx

ULINE H-9236, H-9248

TENTE POUR ÉVÉNEMENTS

– 20 x 40 pi

1-800-295-5510
uline.ca

OUTILS REQUIS



Masse
(pour H-9236)

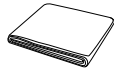

Toile de protection
(recommandé)



Montage à trois
personnes recommandé

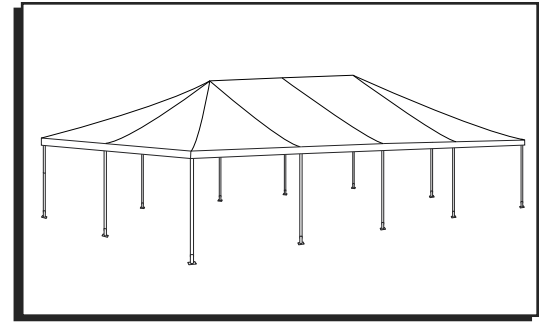

PIÈCES

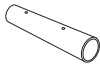

Poteau

Pied (LG) de 6 pi 8 po, noir x 12
 Avant-toit (EV) de 9 pi 4 po, blanc x 12
 Rive (RG) de 9 pi 4 po, blanc x 2
 Chevron complet (FR) de 10 pi 6 po, vert x 8
 Chevron d'appui (HR) de 14 pi 4 po, rouge x 4

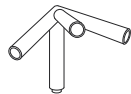

Raccord de
coin x 4

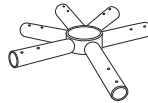

Raccord en
couronne à 6
branches x 2



Raccord en
couronne
pour rive x 1

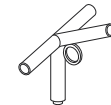

Raccord en T à 4
branches x 8



Sangle à
cliquet de
2 po x 12



Plaque de base x 12



Étrier x 76

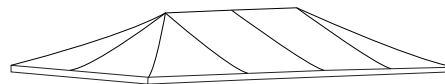

Toit en auvent x 1



Piquet en acier x 12
(pour H-9236)



Baril x 12
(pour H-9248)

Matériel d'installation pour baril



Étrier x 12

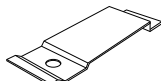

Plaque de
montage x 12



Rondelle plate
3/8 po x 12



Rondelle plate
5/8 po x 24



Écrou hexagonal
3/8 po x 12

SÉCURITÉ



IMPORTANT! Veuillez lire attentivement.

- Gardez à l'écart des sources de chaleur et des flammes.
- Ne cuisinez pas en dessous ou à proximité de l'auvent.
- N'utilisez pas et n'entreposez pas de liquides inflammables en dessous ou à proximité de l'auvent.
- N'utilisez pas et n'entreposez pas de feux d'artifice en dessous ou à proximité de l'auvent.
- N'utilisez pas de javellisant pour nettoyer la bâche.

- N'effectuez pas de nettoyage à sec.
- Ne nettoyez pas la bâche en machine, et ne la séchez pas dans la sècheuse. Nettoyez à la main avec du savon doux et de l'eau uniquement.
- Ne suspendez rien sur le cadre, les œillets ou l'armature de l'auvent.
- Ne laissez pas l'eau de pluie, la neige et la glace s'accumuler sur le dessus.
- Enlevez l'eau de pluie, la neige et la glace du dessus de la bâche.



REMARQUE : Ceci n'est qu'une structure temporaire et il n'est pas recommandé de s'en servir en tant que structure permanente.

MONTAGE



IMPORTANT! Avant le montage, veuillez contacter InfoExcavation ou les autorités locales pour vous assurer que l'édification de la tente à l'emplacement choisi est sans danger. Prenez connaissance des conditions météorologiques, et évacuez systématiquement la tente par temps de grand vent ou en présence d'orages.

1. Assurez-vous que toutes les pièces sont présentes avant de commencer le montage. Déposez les pièces du cadre sur le sol à l'emplacement approximatif où elles s'insèrent dans la structure. (Voir Figure 1)

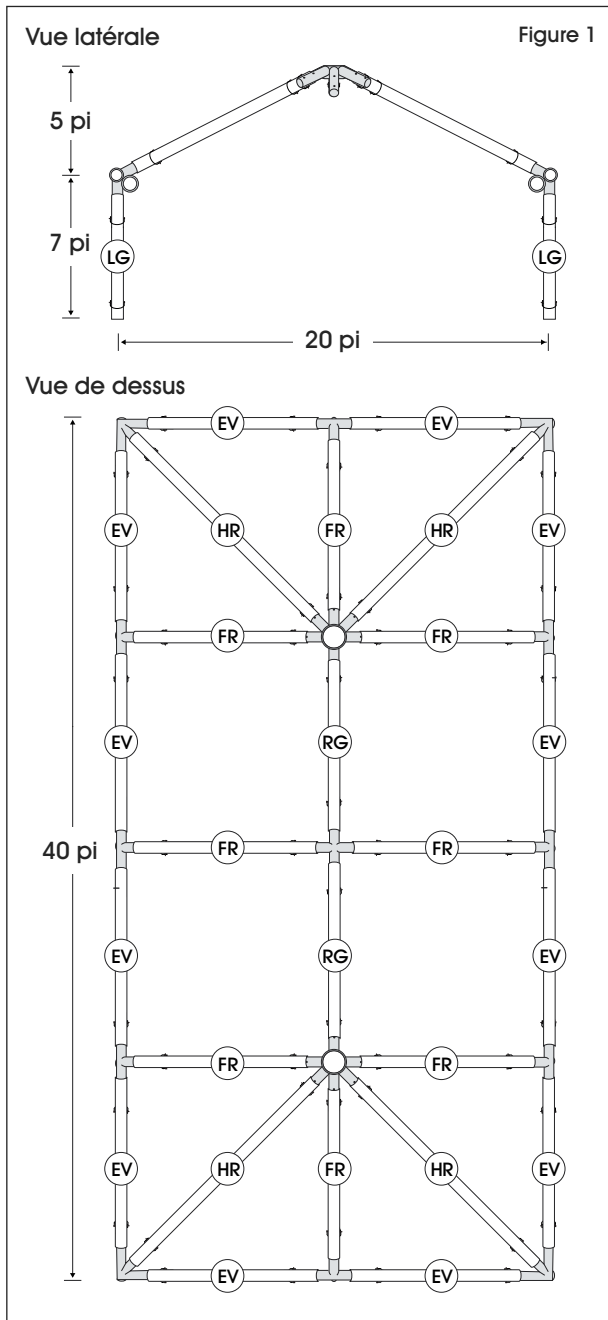

2. Placez les goupilles pour cadre dans le raccord en couronne à 6 branches.
 - a. Chacune des branches du raccord en couronne est munie de deux trous. Le trou d'alignement est plus proche du centre; le trou de positionnement est situé plus bas le long de la branche. (Voir Figure 2)

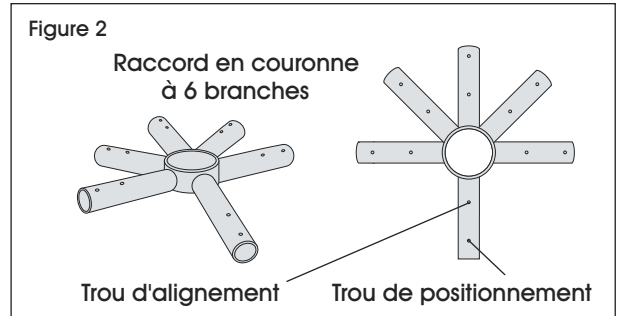

- b. Placez une étrier dans chaque trou d'alignement. La goupille empêche le chevron de coulisser trop loin le long du raccord en couronne à 6 branches. (Voir Figure 3)

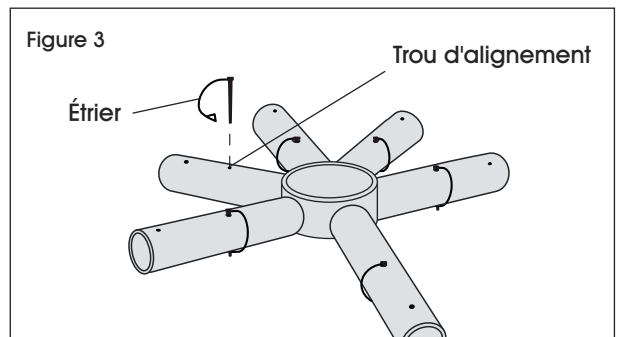

3. Positionnez deux chevrons d'appui (HR) sur le raccord en couronne à 6 branches. (Voir Figure 4)

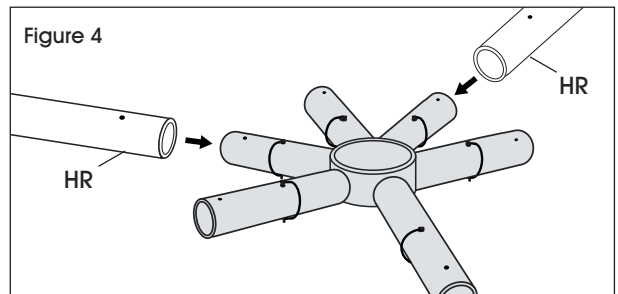

MONTAGE SUITE

- a. Faites coulisser les chevrons d'appui (HR) sur les branches jusqu'à la goupille. (Voir Figure 5)

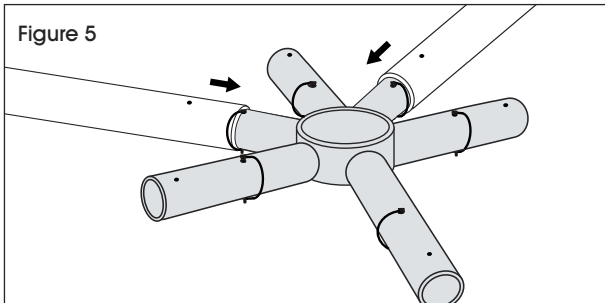

- b. Faites coïncider le trou de positionnement du raccord en couronne avec le trou du chevron et insérez la étrier. (Voir Figure 6)

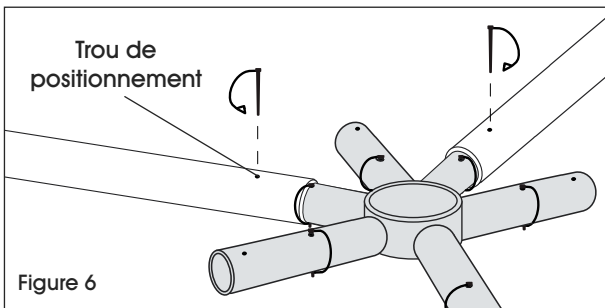

- c. Retirez les goupilles des trous d'alignement aux endroits où les chevrons d'appui (HR) sont fixés au raccord en couronne. (Voir Figure 7)

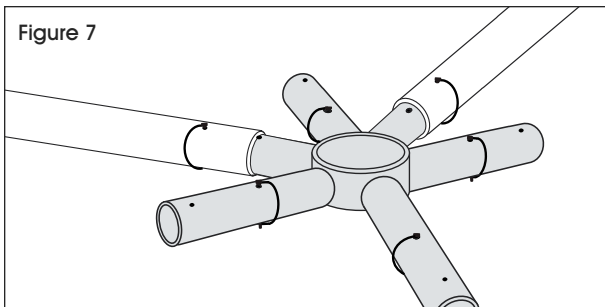

4. Répétez les étapes 3b à 3c pour connecter trois chevrons complets (FR) au raccord en couronne à 6 branches. (Voir Figure 8)

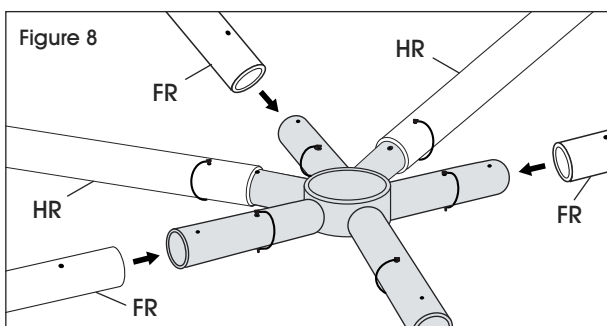

5. En prenant pour point de départ un raccord de coin, fixez les poteaux d'avant-toit (EV) aux raccords de coin et aux raccords en T à 4 branches, en progressant dans le sens horaire autour de la structure pour compléter la première travée d'extrémité. Fixez aux chevrons d'appui (HR) et aux chevrons complets (FR). (Voir Figures 9 et 10)

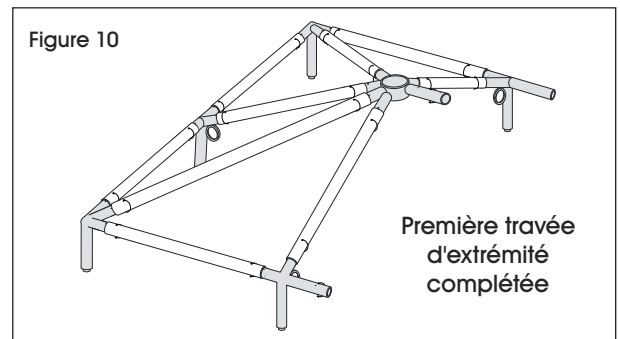
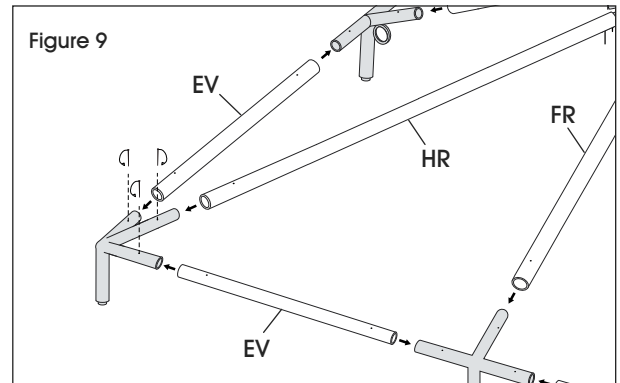

6. Répétez les étapes 2 à 5 pour compléter la seconde travée d'extrémité. (Voir Figure 11)

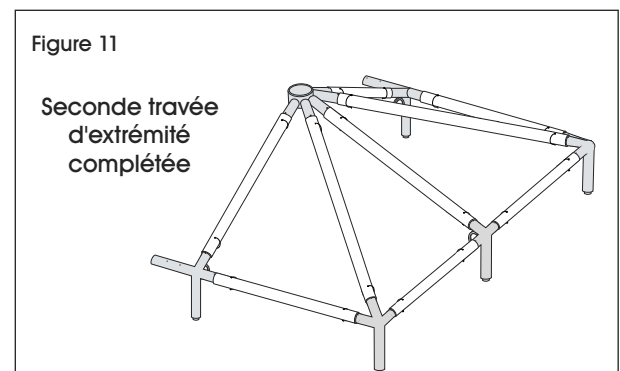

MONTAGE SUITE

7. Connectez le raccord en couronne pour rive et deux chevrons complets (FR) à deux raccords en T à 4 branches pour former le cadre central. Fixez à l'aide des étriers. (Voir Figure 12)

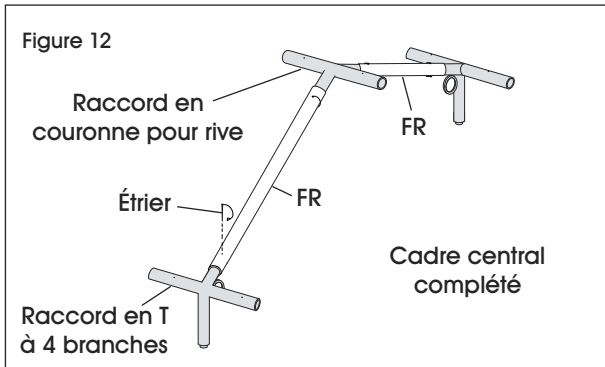

8. Connectez les travées d'extrémité au cadre central avec deux poteaux de rive (RG) et quatre poteaux d'avant-toit (EV). Fixez à l'aide des goupilles pour cadre. (Voir Figure 13)

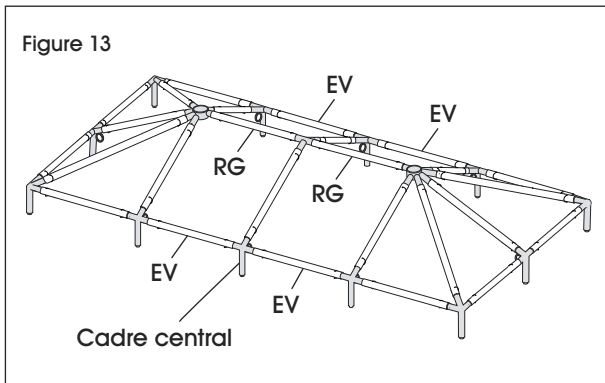

9. Effectuez une boucle avec la sangle à cliquet pour la fixer au raccord à chaque emplacement de pied. (Voir Figure 14)

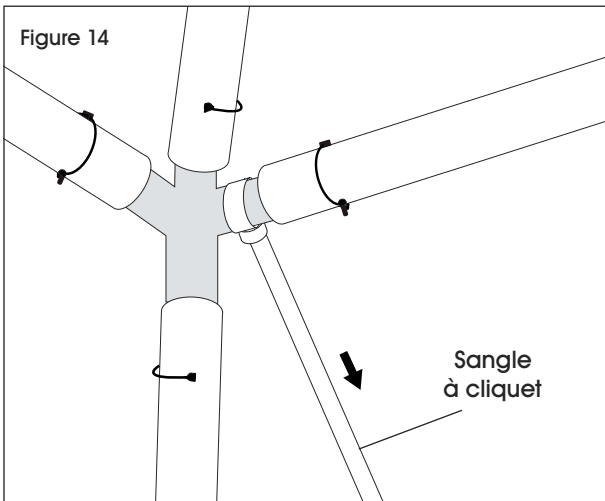

10. Déroulez le toit de la tente. (Voir Figures 15 et 16)

 **REMARQUE :** Il est recommandé de placer le toit de la tente sur une toile de protection pour éviter les salissures ou les abrasions.

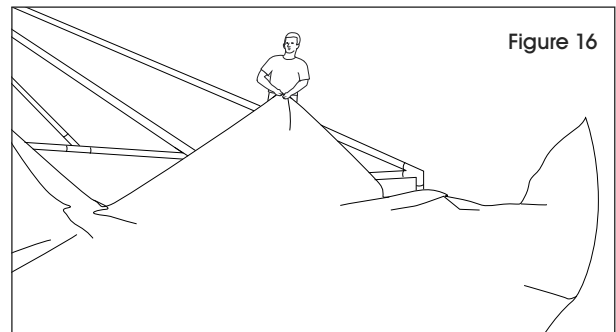
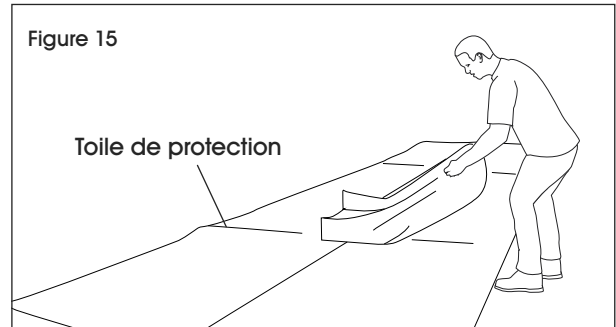

11. Étendez le toit de la tente par-dessus le cadre, tout en soulevant le tissu pour créer un coussin d'air en dessous du toit de la tente. (Voir Figure 17)

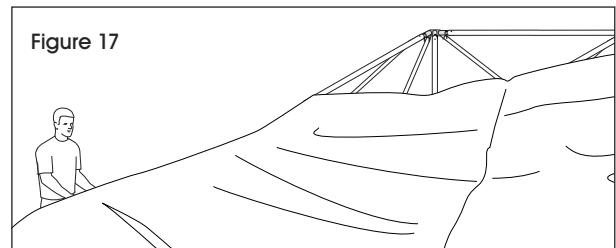

12. Centrez le toit de la tente sur le cadre en alignant les coutures le long des chevrons d'appui (HR). (Voir Figure 18)

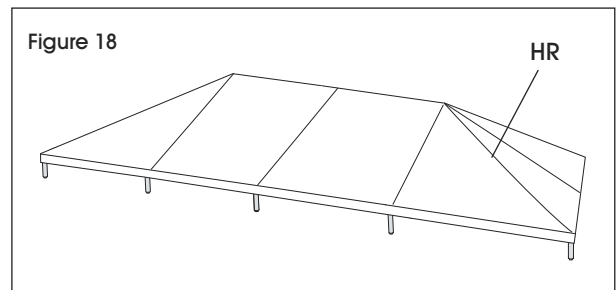

MONTAGE SUITE

13. Attachez de façon lâche les sangles à pince crocodile et fixez-les sur les coins de l'auvent autour des poteaux d'avant-toit (EV) afin de sécuriser le toit de la tente. (Voir Figure 19)

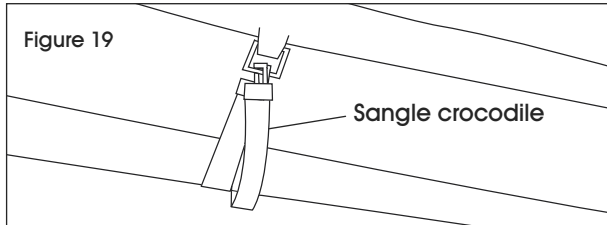

14. Fixez les plaques de base aux pieds à l'aide des étriers. (Voir Figure 20)

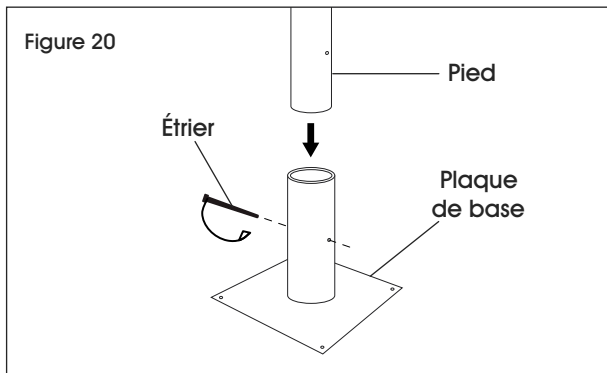

15. Soulevez le côté du cadre situé sous le vent et maintenez tous les côtés de niveau. Fixez les poteaux de pied du côté soulevé. (Voir Figure 21)

 **REMARQUE :** Soulevez toujours le côté orienté sous le vent en premier.

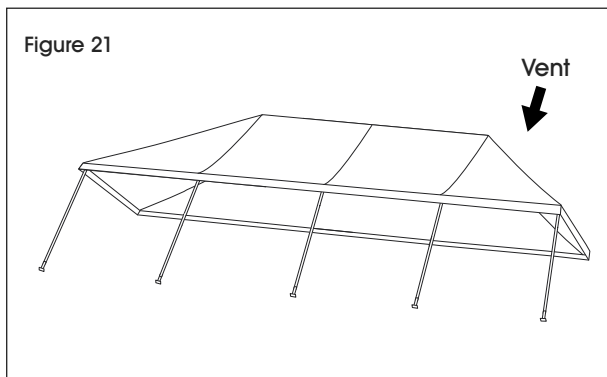

16. Soulevez l'autre côté de la tente et fixez les pieds restants. (Voir Figure 22)

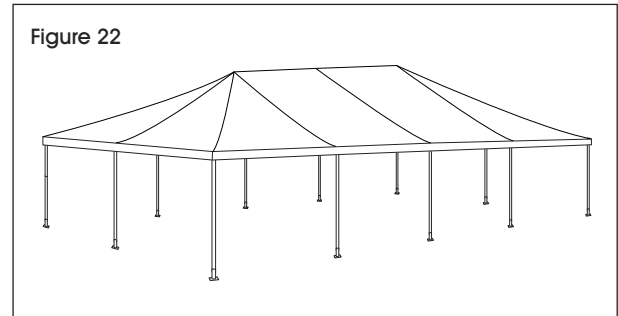

17. Attachez les sangles crocodile restantes autour des poteaux d'avant-toit (EV) en tirant sur l'excédent de sangle pour tendre le tissu et les sangles fermeture. Faites passer l'excédent de sangle à travers la boucle en métal de la pince crocodile. (Voir Figure 23)

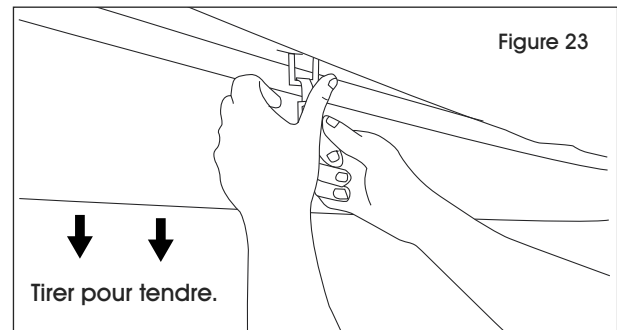

MISE EN GARDE! Une tension excessive exercée sur les sangles provoquera une usure prématurée ainsi qu'un froissement du tissu du toit de la tente.

SI VOUS UTILISEZ DES PIQUETS (H-9236)

1. Placez les piquets à une distance de 5 pi de chaque pied. Enfoncez les piquets dans le sol en laissant dépasser d'une hauteur de 6 po ou moins hors du sol. (Voir Figure 24)

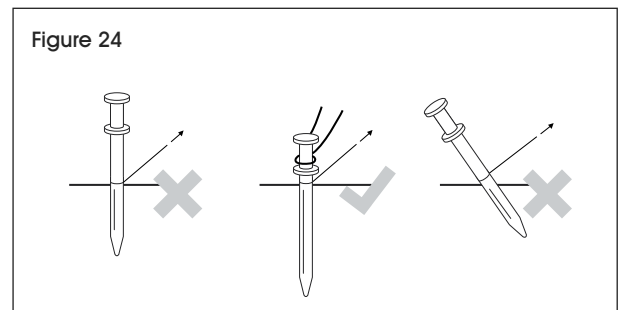

MONTAGE SUITE

2. Attachez de façon lâche les sangles à cliquet aux piquets. (Voir Figure 25)
 - a. Attachez le mécanisme de fixation à cliquet muni d'une sangle à boucle aux piquets en retournant la boucle de 6 po située à l'extrémité du cliquet et en y faisant passer la sangle à travers.
 - b. Resserrez le nœud à plein poing autour du piquet.
 - c. Saisissez la sangle à boucle attachée à la tente et faites-la passer à travers la fente entre les barres de l'enrouleur à cliquet.

 **REMARQUE :** Maintenez la poignée du mécanisme de fixation à cliquet orientée vers le haut en permanence.

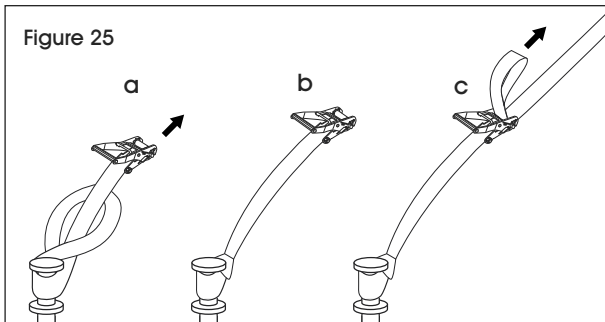

3. Resserrez les sangles à cliquet en maintenant la sangle et en faisant passer le mou à travers l'enrouleur à cliquet. Faites passer tout le mou à travers l'enrouleur à cliquet en maintenant la sangle d'une main tandis que l'autre main actionne la poignée à cliquet.

4. Enroulez l'excédent des sangles à cliquet et caliez-les dans le mécanisme de fixation à cliquet. (Voir Figure 26)

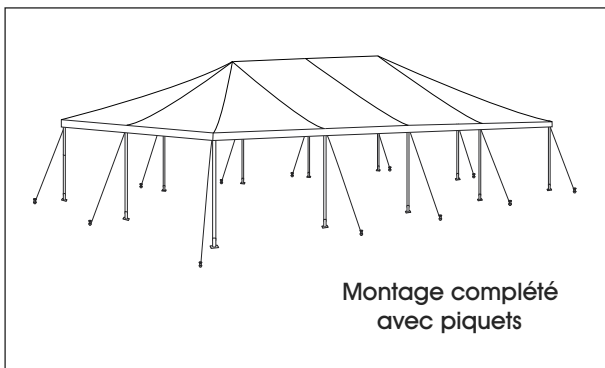
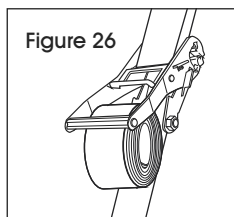

SI VOUS UTILISEZ DES BARILS (H-9248)

1. Mettez le baril à l'envers pour y fixer la plaque de montage. (Voir Figure 27)

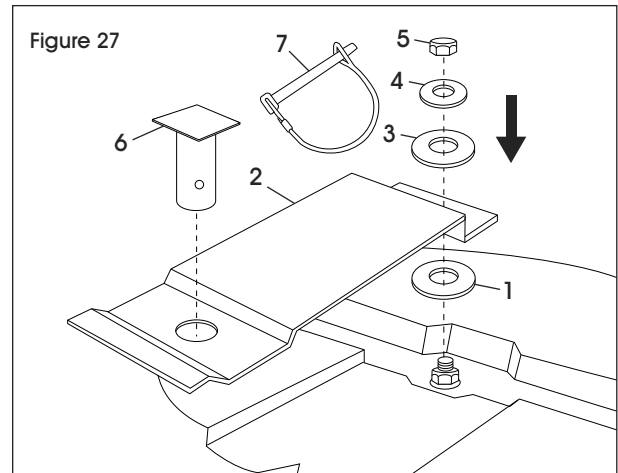

- a. Déposez une rondelle de 5/8 po (1) sur l'écrou et le boulon.
 - b. Placez la plaque de montage (2) par-dessus la rondelle.
 - c. Placez-y une autre rondelle de 5/8 po (3) suivie d'une rondelle de 3/8 po (4).
 - d. Positionnez puis serrez l'écrou de 3/8 po (5).
 - e. Remettez le baril à l'endroit et insérez la plaque de base (6) dans le trou de la plaque.
2. Placez un poteau par-dessus la plaque de base qui a été insérée dans la plaque. Insérez l'étrier (7) à travers le poteau et la plaque de base pour fixer le tout. (Voir Figure 28)

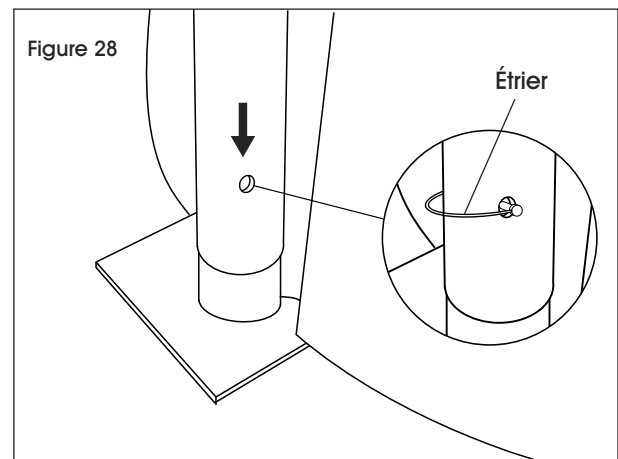

MONTAGE SUITE



REMARQUE : Attachez la sangle au fond du baril avant de remplir le baril d'eau.
(Voir Figure 29)

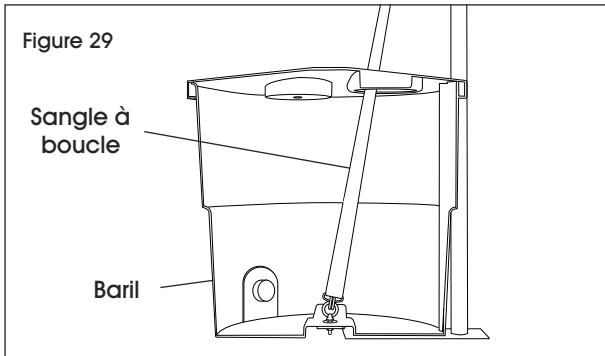

3. Pour connecter la sangle au boulon à œil se trouvant au fond du baril, faites passer la sangle à boucle à travers le boulon à œil. Saisissez l'autre extrémité de la sangle et faites-la passer tout entière à travers la boucle. Tirez l'extrémité longue afin de sécuriser la sangle au boulon à œil. (Voir Figure 30)

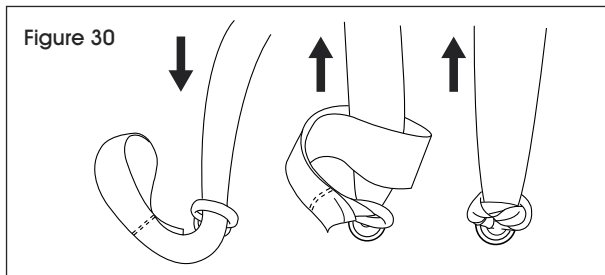

4. Faites passer la sangle à travers la fente du couvercle. (Voir Figure 31)

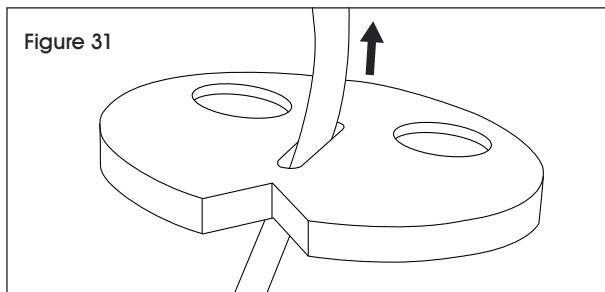

5. Connectez l'extrémité opposée de la sangle au raccord se trouvant au sommet du poteau, et non autour des poteaux formant le cadre de la tente. Ceci constitue un triangle solide. (Voir Figure 32)

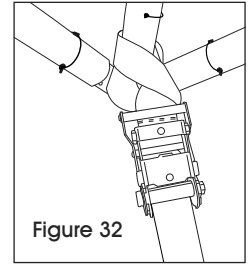

6. Remplissez le baril d'eau.



REMARQUE : Maintenez la poignée du mécanisme de fixation à cliquet orientée vers le haut en permanence.

7. Une fois le baril rempli, resserrez les sangles à cliquet en faisant passer tout le mou à travers l'enrouleur à cliquet et en maintenant la sangle d'une main tandis que l'autre main actionne la poignée à cliquet.
8. Enroulez l'excédent des sangles à cliquet et caliez-les dans le mécanisme de fixation à cliquet. (Voir Figure 33)

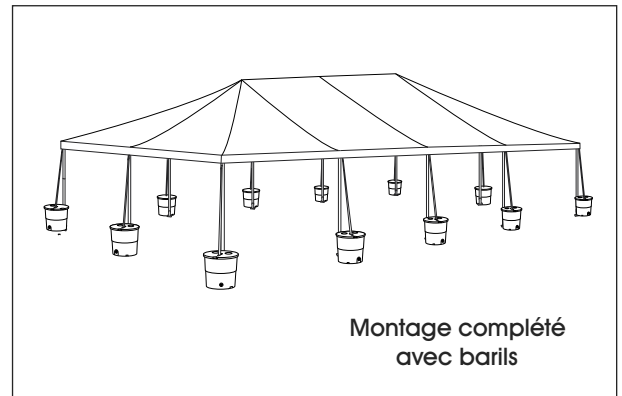
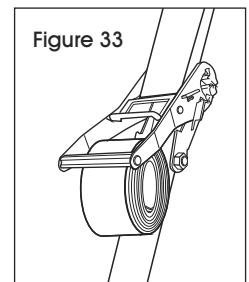

DÉMONTAGE DE LA TENTE



Démontage à trois personnes recommandé

1. Desserrez les ensembles de sangle à cliquet et décrochez les sangles des piquets ou des barils.



REMARQUE : Si vous utilisez des barils, vidangez-les. Soulevez chacun des pieds et retirez les goupilles des barils, en prenant soin de reposer les pieds sur le sol et non à nouveau sur les barils. Éloignez les barils de la tente afin qu'il y ait suffisamment d'espace pour abaisser la tente.

2. Retirez les trois pieds centraux sur le côté long et les deux pieds latéraux adjacents. (Voir Figure 34)

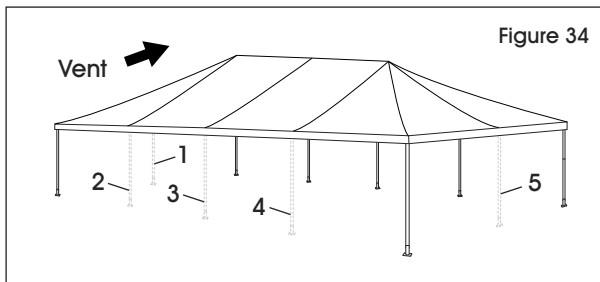

3. Détachez toutes les sangles crocodile hormis les deux situées dans chacun des coins (une sangle de chaque côté du raccord en coin). (Voir Figure 35)

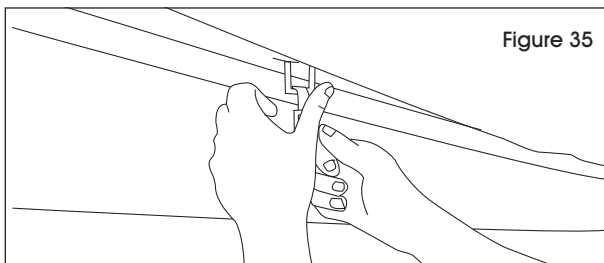

4. Commencez du côté au vent. Faites-vous aider par une autre personne pour retirer les deux pieds situés aux coins d'un côté, puis déposez délicatement la tente sur le sol. (Voir Figures 36 à 38)

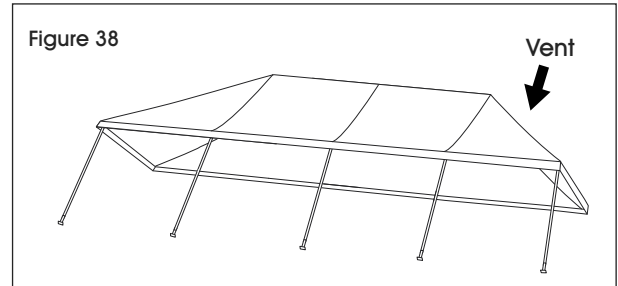
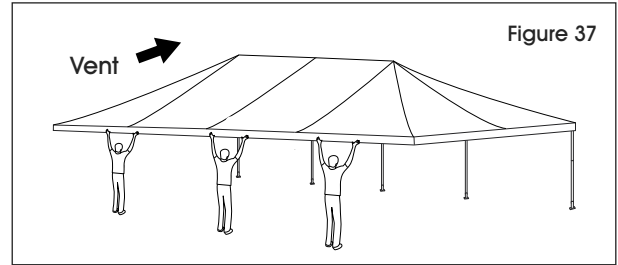
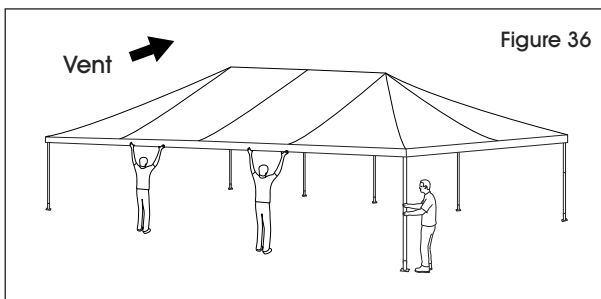

5. Retirez les pieds restants. (Voir Figure 39)

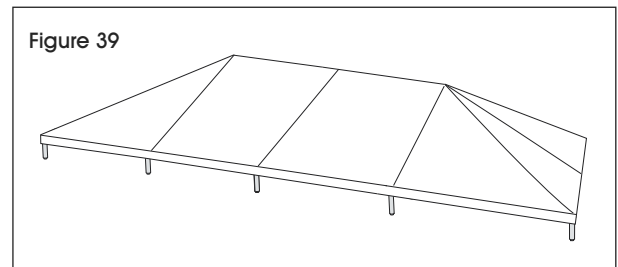

6. Détachez les sangles restantes jusqu'à les déconnecter complètement.
7. Retirez le toit de la tente du cadre.
8. Pliez et enroulez les pièces du toit de la tente de manière aussi serrée que possible. Utilisez un pliage en accordéon ou en paravent pour de meilleurs résultats.



REMARQUE : Pour une meilleure longévité de la tente, ne marchez pas et ne vous tenez pas debout sur le toit de la tente. Il est recommandé de sécher et d'essuyer le toit en tissu de la tente avant de le plier pour l'entreposage.

9. Désassemblez tous les raccords de coin, les raccords latéraux en T et le raccord central en couronne en retirant les goupilles et en détachant les tubes des raccords. Progresser depuis le périmètre du cadre vers l'intérieur.
10. Retirez tous les piquets. Si vous utilisez des barils, videz l'eau pour l'entreposage.

ULINE

1-800-295-5510

uline.ca