

ZD421 and ZD621 Series

Link-OS[®] Printers



ZEBRA

User Guide

ULINE H-9579
1-800-295-5510

0721 IH-9579VND
P1123730-01EN

ZEBRA and the stylized Zebra head are trademarks of Zebra Technologies Corporation, registered in many jurisdictions worldwide. All other trademarks are the property of their respective owners.
© 2021 Zebra Technologies Corporation and/or its affiliates. All rights reserved.

Information in this document is subject to change without notice. The software described in this document is furnished under a license agreement or nondisclosure agreement. The software may be used or copied only in accordance with the terms of those agreements.

For further information regarding legal and proprietary statements, please go to:

SOFTWARE: zebra.com/linkoslegal

COPYRIGHTS: zebra.com/copyright

WARRANTY: zebra.com/warranty

END USER LICENSE AGREEMENT: zebra.com/eula

Terms of Use

Proprietary Statement

This manual contains proprietary information of Zebra Technologies Corporation and its subsidiaries ("Zebra Technologies"). It is intended solely for the information and use of parties operating and maintaining the equipment described herein. Such proprietary information may not be used, reproduced, or disclosed to any other parties for any other purpose without the express, written permission of Zebra Technologies.

Product Improvements

Continuous improvement of products is a policy of Zebra Technologies. All specifications and designs are subject to change without notice.

Liability Disclaimer

Zebra Technologies takes steps to ensure that its published Engineering specifications and manuals are correct; however, errors do occur. Zebra Technologies reserves the right to correct any such errors and disclaims liability resulting therefrom.

Limitation of Liability

In no event shall Zebra Technologies or anyone else involved in the creation, production, or delivery of the accompanying product (including hardware and software) be liable for any damages whatsoever (including, without limitation, consequential damages including loss of business profits, business interruption, or loss of business information) arising out of the use of, the results of use of, or inability to use such product, even if Zebra Technologies has been advised of the possibility of such damages. Some jurisdictions do not allow the exclusion or limitation of incidental or consequential damages, so the above limitation or exclusion may not apply to you.

Publication Date

March 29, 2021

Contents

About	11
Printer Resources	11
Zebra OneCare Printer Service and Support	12
Icon Conventions	12
Introduction	13
Link-OS 4 inch Desktop Thermal Printers	13
Common Desktop Link-OS Printer Features	14
Link-OS 4 inch Desktop Printer Options	15
Zebra Label Printing Solution	17
Modes of Printing	17
What's in the Box?	18
Unpack and Inspect the Printer	18
Printer Features	20
Inside the ZD421 Dual Capacity Ribbon Roll Printer	22
Inside the ZD621 Dual Capacity Ribbon Roll Printer	23
Inside the ZD421 Direct Thermal Printers	26
Inside the ZD621 Direct Thermal Printers	27
Inside the ZD421 Ribbon Cartridge Printer	28
Label Dispenser Option (field installable) - All Models	30
Cutter Option (field installable) - All Models	30
Linerless Media Tear-Off Option (Direct Thermal Models Only)	31
Linerless Cutter Option (Direct Thermal Models Only)	31
Identifying Platen Drive Rollers Types	32
Printer Power Supply Options	33
ZD621 Direct Thermal Locking Printer Features	35
Zebra Print Touch	36

Controls and Indicators	37
User Interface.....	37
Standard Interface Controls.....	38
Meaning of the Indicator Light Patterns	41
Status - Typical Operating Conditions	41
Status - Printhead Operation	43
Status - Bluetooth Low Energy (BTLE) Option	44
Status - Ethernet (LAN) Option.....	44
Status - Wi-Fi (WLAN) Option	45
Battery Indicators and Controls.....	45
Install Hardware Options	47
Field Installable printer Accessories and Options	47
Printer Connectivity Modules	49
Accessing the Connectivity Module Slot.....	49
Installing the Serial Port Module.....	50
Installing the Internal Ethernet (LAN) Module.....	51
Installing the Wireless Connectivity Module	53
Media Handling Options.....	56
Removing the Standard Bezel.....	56
Installing the Label Dispenser	57
Installing the Standard Media Cutter	58
Installing the Linerless Media Cutter	59
Installing the Linerless Media ‘Tear-Off’ Bezel	60
Media Roll Core Size Adapters	61
Print Resolution Upgrade Kits	63
Installing the Attached Power Supply Base Options	64
Installing the Attached Battery Base Options	66
Installing the Battery into the Attached Power Base.....	67
Color Touch Display and Controls.....	68
Color Touch Display Printer Controls.....	69
Home Screen	70
Printer Status.....	70
Printer Info	71
Printer Wizards	72
User Menus	74
System Menu	75
System > Language.....	76
System > Program Language > Diagnostic Mode.....	77

System > Program Language > Virtual Device	78
System > Program Language > ZBI	79
System > Settings > Display Time Format	80
System > Settings > Password Level	81
System > Settings > Set Password	82
System > Settings > Power Up Action.....	83
System > Settings > Head Close Action.....	84
System > Settings > Screen Calibration.....	85
System > Settings > Restore Defaults.....	86
System > Settings > Print: System Settings	87
System > Energy Saving > Energy Star	88
Connection Menu	89
Connection > Networks > Reset Network.....	90
Connection > Networks > Primary Network.....	91
Connection > Networks > IP Port	92
Connection > Networks > IP Alternate Port.....	93
Connection > Networks > Print: Network Info.....	94
Connection > Networks > Visibility Agent.....	95
Connection > Wired > Wired IP Protocol.....	96
Connection > Wired > Wired IP Address	97
Connection > Wired > Wired Gateway	98
Connection > Wired > Wired Mac Address	99
Connection > WLAN > WLAN IP Protocol.....	100
Connection > WLAN > WLAN IP Address.....	101
Connection > WLAN > WLAN Subnet.....	102
Connection > WLAN > WLAN Gateway	103
Connection > WLAN > WLAN Mac Address	104
Connection > WLAN > ESSID	105
Connection > WLAN > WLAN Security	106
Connection > WLAN > WLAN Band	107
Connection > WLAN > WLAN Country Code	108
Connection > Bluetooth > Bluetooth.....	109
Connection > Bluetooth > Bluetooth Discovery	110
Connection > Bluetooth > Friendly Name.....	111
Connection > Bluetooth > Minimum Security Mode	112
Connection > Bluetooth > Specification Version	113
Connection > Bluetooth > MAC Address.....	114
Connection > Bluetooth > Bluetooth Auth. PIN	115
Connection > Bluetooth > Bluetooth Bonding.....	116
Print Menu.....	117
Print > Print Quality > Darkness	118

Print > Print Quality > Print Speed.....	119
Print > Print Quality > Print Type	120
Print > Print Quality > Label Type.....	121
Print > Print Quality > Label Length.....	122
Print > Print Quality > Label Width (Dots).....	123
Print > Label Position > Collection Method.....	124
Print > Label Position > Tear Line Offset.....	125
Print > Label Position > Horizontal Label Offset.....	126
Print > Label Position > Vertical Label Offset.....	127
Print > Sensors > Manual Calibration.....	128
Print > Sensors > Label Sensor.....	129
Print > Sensors > Sensor Type	130
Print > Sensors > Print: Sensor Profile.....	131
Print > Print Station.....	132
Print > Applicator > Applicator Port Mode	133
Print > Applicator > Start Print Mode.....	134
Print > Applicator > Error on Pause.....	135
Print > Applicator > Applicator Reprint	136
RFID Menu.....	137
RFID > RFID Status.....	138
RFID > RFID Test.....	139
RFID > RFID Calibrate	140
RFID > Read Power	141
RFID > Write Power.....	142
RFID > RFID Antenna	143
RFID > RFID Valid Count	144
RFID > RFID Void Count.....	145
RFID > RFID Program Position	146
RFID > Read RFID Data.....	147
Storage Menu.....	148
Storage > USB > Copy: Files to USB	149
Storage > USB > Copy: Files to Printer.....	150
Storage > USB > Copy: Configuration to USB.....	151
Storage > USB > Print: From USB	152
Storage > Print Asset Lists	153
Storage > USB > Print from E:	154
Setup.....	155
Printer Setup Overview	155
Select a Location for the Printer.....	155
Install Printer Options and Connectivity Modules.....	156

Attaching Power	156
Getting Ready to Print.....	157
Preparing and Handling Media	157
Media Storage Tips	158
Loading Roll Media	158
Setting Media Sensing by Media type	158
Instructions for media loading:.....	159
Loading Thermal Transfer Roll Ribbon	165
Loading Zebra Transfer Roll Ribbon	166
Loading the ZD421 Ribbon Cartridge	176
Run a SmartCal Media Calibration.....	177
SmartCal Procedure	177
Test Printing with the Configuration Report	178
Detecting a Media Out Condition	179
Detecting a Ribbon Out Condition.....	180
Connecting your Printer to a Computer.....	181
Interface Cable Requirements.....	181
Wi-Fi and Bluetooth Classic Wireless Connectivity Option	185
Setup for Windows® OS.....	186
Windows to Printer Communication Setup (Overview)	186
Pre-install Windows® Printer Drivers	186
Setting Up the Wi-Fi Print Server Option	187
Configure Using the ZebraNet Bridge Connectivity Wizard	187
Using a Configuration Script.....	194
Bluetooth Option Configuration.....	195
Connecting to a Windows XP® SP2 Central Device.....	198
Connecting to a Windows Vista® SP2 or Windows 7® Central Device	199
Connecting the Printer to a Windows 8	202
Connecting the Printer to a Windows 10 PC	203
After Your Printer is Connected	205
Print Operations.....	208
Thermal Printing.....	208
Determining Your Printer's Configuration Settings	208
Select a Print Mode or Collection Method.....	208
Adjusting the Print Quality.....	209
Adjusting the Print Width.....	209
Replacing Supplies while Using the Printer	210
Printing on Fan-Fold Media.....	210

Printing with Externally Mounted Roll Media 213
 Externally Mounted Roll Media Considerations: 213
 Using the Label Dispenser Option 214
 Using the Linerless Options 217
 Linerless Printing 218
 Sending Files to the Printer 218
 Ribbon Cartridge Programming Commands 218
 Printing with the Attached Battery Base and Battery Option 219
 Printer Fonts 220
 Identifying Fonts in Your Printer 220
 Localizing the Printer with Code Pages 220
 Asian fonts and Other Large Font Sets 221
 EPL Line Mode - Direct Thermal Printers only 222
 ZD621 and ZD421 Locking Printer Option 222
 Zebra® ZKDU — Printer Accessory 223
 ZBI 2.0™ — Zebra Basic Interpreter 223
 Setting the Power Failure Recovery Mode Jumper 224

USB Host Port and Link-OS Usage Examples 225

USB Host 225
 Using USB Host for Firmware Updates 226
 USB Host and Printer Usage Examples 227
 Items Required for the USB Host Exercises 227
 Files for Completing the Exercises 227
 Exercise 1: Copy Files to a USB Flash Drive and Perform USB Mirror 230
 Exercise 2: Print a Label Format from a USB Flash Drive 232
 Exercise 3: Copy Files to/from a USB Flash Drive 234
 Exercise 4: Enter Data for a Stored File with a USB Keyboard and Print a Label 236
 Using the USB Hosts Port and the NFC Capabilities 237
 Exercise 5: Enter Data for a Stored File with a Smart Device and Print a Label.. 238

Maintenance 240

Cleaning 240
 Cleaning Supplies 240
 Recommended Cleaning Schedule 241
 Cleaning the Printhead 243
 Media Path Cleaning 246
 Sensor Cleaning 251
 Platen Cleaning and Replacement 255
 Replacing the Printhead 259

ZD621 and ZD421 Direct Thermal	260
ZD621 and ZD421 Thermal Transfer Ribbon Roll	264
ZD421 Thermal Transfer Ribbon Cartridge	269
Updating Printer Firmware	273
Other Printer Maintenance	273
RTC Battery	273
Fuses	273
Troubleshooting	274
Resolving Alerts and Errors	274
Alert: Printhead Open	274
Alert: Media Out	275
Alert: Ribbon In (ZD421 Cartridge Printer only)	277
Alert: Ribbon Out	278
Alert: Ribbon Low (ZD421 Cartridge Printer only)	279
Alert: CUT ERROR	280
Alert: PRINTHEAD OVER TEMP	281
Alert: PRINTHEAD SHUTDOWN	282
Alert: PRINTHEAD UNDER TEMP	283
Alert: OUT OF MEMORY	284
Resolving Print Issues	285
Issue: General Print Quality Issues	285
Issue: No Print on the Label	286
Issue: Labels Are Distorted in Size or Print Area Start Position Varies	287
Communication Issues	288
Issue: Label Job Sent, No Data Transfer	288
Issue: Label Job Sent, Skips Labels or Prints Bad Content	288
Issue: Label Job Sent, Data Transfers, But No Print	289
Miscellaneous Issues	290
Issue: Settings are Lost or Ignored	290
Issue: Non-continuous labels act as Continuous labels.	291
Issue: Printer Locks-Up	291
Issue: Erroneous Ribbon Cartridge Faults	291
Issue: Battery has a Red Indicator	292
Tools	293
Printer Diagnostics	293
Power-On Self Test	293
SmartCal Media Calibration	293
Configuration Report (CANCEL Self Test)	294

Printer Network (and Bluetooth) Configuration Report	295
Print Quality Report (FEED self test)	296
Reset Printer Factory Defaults (PAUSE + FEED Self Test)	299
Reset Network Factory Defaults (PAUSE + CANCEL Self Test)	299
Reset Button	300
Communication Diagnostics Test	301
Sensor Profile	302
Advanced Mode	303
Manual Media Calibration	303
Manual Print Width Adjustment	304
Manual Print Darkness Adjustment	305
Factory Test Modes	306
Interface Wiring.....	307
Universal Serial Bus (USB) Interface	307
Serial Port Interface	308
Connecting the Printer to a DTE Device.....	308
Connecting the Printer to a DCE Device	309
Dimensions	310
ZD621 / ZD421 Thermal Transfer Models	311
ZD421 Ribbon Cartridge Thermal Transfer Models	319
ZD621 / ZD421 Direct Thermal Models	327
Media.....	334
Types of Thermal Media	334
Determining Thermal Media Types	334
General Media and Print Specifications	335
ZPL Configuration	339
Managing the ZPL Printer Configuration.....	339
Configuration Setting to Command Cross-reference	341
Printer Memory Management and Related Status Reports	344
ZPL Programming for Memory Management	344

About

This guide is for integrators and operators of Zebra Link-OS ZD421 desktop printers. Use this guide to install, change configuration, operate, and physically support these printers.

Information, support, and additional resources are available online to support this printer:

- ZD621 Thermal Transfer printer — zebra.com/ZD621t-info
- ZD621 Direct Thermal printer — zebra.com/ZD621d-info
- ZD421 Thermal Transfer Ribbon Cartridge printer — zebra.com/ZD421c-info
- ZD421 Thermal Transfer printer — zebra.com/ZD421t-info
- ZD421 Direct Thermal printer — zebra.com/ZD421d-info
- ZD621R Thermal Transfer printer — zebra.com/ZD621r-info

Printer Resources

Zebra has a large suite of technical resource for your Zebra Link-OS printer, as well as free and fee-based software and Apps (applications), including:

- “How To” videos
- Printer accessory, supplies, parts, and software links
- Various setup and configuration guides
- Programmer’s manuals
- Printer Drivers (Windows, Apple, OPOS, etc.)
- Printer Firmware
- Printer Fonts
- Utilities
- Knowledge base and support contacts
- Printer warranty and repair links
- Label Design software
- Printer Management tools
- Virtual Devices for legacy languages normally associated with other printer brands
- Cloud-based Enterprise printer management and printing
- XML and PDF format file printing

- Oracle and SAP support
- Zebra Savanna™ Data Intelligence platform - turns raw data from devices (IoT) and sensors into actionable intelligence for your business
- A suite of Link-OS Mobile Apps (applications for phones, tablets, etc.)
- Link-OS software development kit (SDK)
- Additional Operating Systems (OS) and Service platforms

Find out more about ZebraLink, Zebra Link-OS, and Zebra Savanna at zebra.com/software.

Zebra OneCare Printer Service and Support

For maximum productivity, we can help your business ensure its Zebra printers are Online and ready for business. Refer to the descriptions of the Zebra OneCare service and support options available for your printers at zebra.com/zebraonecare.

Icon Conventions

The documentation set is designed to give the reader more visual clues. The following graphic icons are used throughout the documentation set. These icons and their associated meanings are described below.



NOTE: The text here indicates information that is supplemental for the user to know and that is not required to complete a task.



IMPORTANT: The text here indicates information that is important for the user to know.



CAUTION—EYE INJURY: Wear protective eyewear when performing certain tasks.



CAUTION—PRODUCT DAMAGE: If the precaution is not taken, the product could be damaged.



CAUTION: If the precaution is not heeded, the user could receive minor or moderate injury.



CAUTION—HOT SURFACE: Touching this area could result in burns.



CAUTION—ESD: Observe proper electrostatic safety precautions.



CAUTION—ELECTRIC SHOCK: Disconnect the printer power before performing certain procedures to avoid the risk of electric shock.



WARNING: If danger is not avoided, the user CAN be seriously injured or killed.



DANGER: If danger is not avoided, the user WILL be seriously injured or killed.



NOTE: This is an icon for wired networking notes.



NOTE: This is an icon for wireless networking notes.

Introduction

This section introduces the Zebra Link-OS 4-inch desktop thermal label printers, the ZD621 and ZD421. It has an overview of the Link-OS printer's features and options, and what ships with your new printer.

This document covers the following ZD-series desktop printer models:

- ZD621 Thermal Transfer Printer — zebra.com/ZD621t-info
- ZD621 Direct Thermal Printer — zebra.com/ZD621d-info
- ZD421 Thermal Transfer Ribbon Cartridge Printer — zebra.com/ZD421c-info
- ZD421 Thermal Transfer Printer — zebra.com/ZD421t-info
- ZD421 Direct Thermal Printer — zebra.com/ZD421d-info
- ZD621R Thermal Transfer Printer — zebra.com/ZD621r-info

Link-OS 4 inch Desktop Thermal Printers

The Zebra Link-OS 4 inch Desktop printers are compact label printers with a wide range of features and options.

- Direct Thermal and Thermal Transfer printer models available.
- Includes some Healthcare printer model configurations with plastics that withstand common hospital cleaning chemicals and include a medical grade power supply.
- ZD621 printers can support printing speeds* up to 203 mm/s per second (8 ips - inches per second) for 203 dpi (dots per inch print density) printers and 152 mm/s (6 ips) for 300 dpi version printers.
- ZD421 printers can support printing speeds* up to 152 mm/s per second (6 ips) for 203 dpi printers and 102 mm/s (4 ips) for 300 dpi version printers.
- These printers support ZPL™ and EPL Zebra printer programming languages and a wide variety of other printer control languages via Link-OS Virtual Devices.



NOTE: Maximum print speeds vary by model, print resolution, and the type of media in use.

Common Desktop Link-OS Printer Features

- OpenAccess™ design for simplified media loading.
- Color-coded “touch points” for operator controls and media guides.
- Enhanced user interface featuring three buttons and five status indicators.
- Easy, field-installable media handling options.
- Media roll support:
 - Outer Diameter (O.D.): Up to 127 mm (5 in.) and
 - Inner Diameter (I.D.) roll cores: 12.7 mm (0.5 in.), 25.4 mm (1 in.) and additional core sizes with optional media core adapters.
- Movable Sensor provides compatibility with the widest range of media types:
 - Compatible with full or partial width black mark media.
 - Compatible with notched or slotted media.
 - Multi-center position transmissivity sensor for use with label gap/web media.
- Universal Serial Bus (USB) Host Port that can be used for easy firmware updates.
- Universal Serial Bus (USB) 2.0 interface
- ZD621 - The Modular Connectivity Slot has a Serial (RS-232 DB-9) Port and an Ethernet (LAN, RJ-45 connector) with an Internal Print Server that supports 10Base-T, 100Base-TX and fast Ethernet 10/100 auto-switching networks factory installed.
- ZD421 — Modular Connectivity Slot is available for ZD421 field installable 10/100 Ethernet (802.3 RJ-45) with an Internal Print Server or Serial (RS-232 DB-9) interface options.
- On-the-fly OpenType and TrueType font scaling and import, Unicode, resident scalable font (Swiss 721 Latin 1 font), and a selection of resident bitmap fonts.
- Backwards compatibility focused technology eases printer replacement:
 - Drop in replacement of legacy Zebra desktop printers. The printer accepts both EPL and ZPL programming languages.
 - Supports Link-OS virtual devices to interpret non-Zebra printer programming languages.
- XML-Enabled printing—allows XML communications for barcode label printing, eliminating license fees and print server hardware and lowering customization and programming costs.
- Zebra™ Global Printing Solution – supports Microsoft Windows keyboard encoding (and ANSI), Unicode UTF-8 and UTF 16 (Unicode Transformation Formats), XML, ASCII (7 and 8 bit used by legacy programs and systems), basic single and double byte font encoding, JIS and Shift-JIS (Japanese International Standards), Hexadecimal encoding, and custom character mapping (DAT table creation, font linking, and character remapping).
- Support for printer configuration via a setup utility running on mobile devices.
 - Use the printer’s Bluetooth Low Energy (BTLE) feature exclusively for Zebra Link-OS Setup Apps using for short range communication to mobile devices. Bluetooth LE works with Zebra mobile setup utility applications to assist in printer setup, perform media calibration, and maximize print quality.
 - Zebra’s Print Touch (Near Field Communication - NFC) tap- to- pair devices, access printer information, and access mobile applications.

- Zebra's Link-OS - an open platform that connects operating systems for smart Zebra devices with powerful software apps (applications), making the devices easy to integrate, manage and maintain from any location.
- An On-board Real Time Clock (RTC).
- Printhead maintenance reporting enabled and customizable by the user.
- Easy tool-less replacement of printhead and platen (driver) roller.
- A minimum of 64 MB of internal (E:) printer memory for storing forms, fonts, and graphics.

Link-OS 4 inch Desktop Printer Options

- A Color Touch User Interface for easy setup, print configuration, printing, and a range of Link-OS features.
- Factory Installed RFID support with the Color Touch Display with ZD621R thermal transfer printer.
- Healthcare printer models:
 - Healthcare wipe-able plastics for disinfecting and cleaning.
 - IEC 60601-1 certified power supply.
- Factory Installed and Field Installable Wired and Wireless options:
 - Wi-Fi (802.11ac – includes a/b/g/n), Bluetooth Classic 4.1, and Bluetooth Low Energy (LE) 5.0 wireless connectivity.
 - Internal Ethernet Print Server (LAN, RJ-45 connector) — supports 10Base-T, 100Base-TX and fast Ethernet 10/100 auto-switching networks for wired connectivity. This includes Bluetooth Low Energy (LE) wireless connectivity.
 - ZD621 printers include Internal Ethernet Print Server (LAN, RJ-45 connector) — supports 10Base-T, 100Base-TX and fast Ethernet 10/100 auto-switching networks, and Serial (RS-232 DB-9) Port.
- Thermal Transfer Printing - a choice of easy loading thermal transfer ribbon cartridge or dual capacity ribbon roll (74 m and 300 m ribbons) models.
- The printer has a factory installed, on-board Real Time Clock (RTC).
- ZD421 Field installable connectivity modules:
 - Internal Ethernet Print Server (LAN, RJ-45 connector) — supports 10Base-T, 100Base-TX and fast Ethernet 10/100 auto-switching networks.
 - Serial (RS-232 DB-9) Port
- Field installable media handling options:
 - Label Dispenser (Peel-Off liner and present the label for the operator).
 - General purpose media cutter.

- Media Core Adapter kit include adapters for media rolls with Outer Diameters (O.D.) up to 127 mm (5 in.):
 - 38.1 mm (1.5 in.) I.D. media cores.
 - 50.8 mm (2.0 in.) I.D. media cores.
 - 76.2 (3.0 in.) I.D. media cores.
- Attached Power Supply Base with internal power supply.
- Attached Battery Base with removable Battery.
 - Attached Battery Base and Battery are sold separately.
 - The battery provides a constant regulated 24 VDC until the battery shutdown for recharging to maintain print quality. This keeps print from changing as the battery discharges with use.
 - Includes a Shutdown Mode for shipping and storage.
 - Includes battery charge and status indicators built into the battery.
- Asian Language support with printer configuration options for the large Simplified and Traditional Chinese, Japanese, or Korean character sets.
 - Printers sold in China have the Simplified Chinese SimSun font pre-installed.
- Zebra® ZBI 2.0™ (Zebra BASIC Interpreter) programming language. ZBI allows you to create custom printer operations that can automate processes, use peripherals (i.e. scanners, scales, keyboards, Zebra® ZKDU™, etc.) all without being attached to a PC or network.
- Locking Media Cabinet for ZD621 Direct Thermal Healthcare printer models. This special Healthcare model includes for additional security, Kensington™ Slot for Kensington locking devices to secure the printer.

Zebra Label Printing Solution

The printer is just one of three parts of a printing solution. To print; you need a printer (ZD621 or ZD421), compatible media (thermal transfer ribbon cartridge or rolls, and thermal transfer media; or just direct thermal media), and software (driver, applications or programming) to tell the printer what to do and print. The printer can print without being connected to other devices or systems.

The media may be labels, tags, tickets, receipt paper, fan-fold stacks, tamper proof labels, etc.

Zebra assists you with label design and print with the free label and form design software: ZebraDesigner™ for Windows PC operating systems.

Zebra provides a complete suite of free Link-OS software applications and drivers to configure printer settings, print labels and receipts, get printer status, import graphics and fonts, send programming commands, update firmware, and download files.

The Zebra web site or your reseller will be able to help you identify media for your desired use case.

Modes of Printing

You can operate this printer in many different modes and media configurations:

- Direct thermal printing: uses heat sensitive media to print.
- Thermal transfer printing: uses thermal transfer ribbon cartridge or ribbon rolls, where heat and pressure transfers ink from the ribbon to media.
- Standard Tear-Off mode: allows you to tear off each label/receipt or batch print a strip of labels and tear them off after it is printed.
- Label Dispense Mode: if an optional dispenser is installed, the backing material can be peeled away from the label as it is printed. After this label is removed, the next one is printed.
- Media Cutting: if an optional media cutter is installed, the printer can cut the label liner between labels, receipt paper or tag stock.
- Linerless media printing with Cut or Tear-Off label options: allows for easy pick and place label applications.
- Stand-alone: the printer can print without being directly connected to a computer.
 - A printer with the color touch display option can use menus to access and print a label format/form.
 - A Link-OS App connecting via Bluetooth (Wireless option).
 - An auto running label format/form (programming based).
 - A data input device connected to the printer's USB Host port or serial port. This mode accommodates data input devices, such as scanners, weigh scales, a Zebra Keyboard Display Unit (ZKDU), etc.
- Shared network printing: printers configured with Ethernet (LAN) and Wi-Fi interface options include an internal print server.

What's in the Box?

After unpacking, make sure you have all parts shown below. Follow the procedures for inspecting the printer to familiarize yourself with printer parts so you can follow the instructions in this book



Printer



USB Cable



Printer Documentation



Power Supply



Power Cord (varies by locale)

Included with Thermal Transfer Printer (uses ribbon rolls)



Empty Starter Ribbon Cores



Non-Zebra 300 Meter Ribbon Adapters

Unpack and Inspect the Printer

When you receive the printer, immediately unpack it and inspect for shipping damage.

- Save all packing materials.
- Check all exterior surfaces for damage.
- Open the printer and inspect the media compartment for damage to components.

If you discover shipping damage upon inspection:

- Immediately notify the shipping company and file a damage report. Zebra Technologies Corporation is not responsible for any damage to the printer incurred during shipment, and will not cover the repair of this damage under its warranty policy.
- Keep all packaging material for shipping company inspection.
- Notify your authorized Zebra® reseller.

Refer to the Zebra Web site for 'How To' videos on packing and unpacking your printer. Go to [About on page 11](#) for links to one of the 5 basic Link-OS printer variations.

Open the Printer

1. To access the media compartment, pull the release latches towards you and lift the cover.
2. Check the media compartment for loose or damaged components.



CAUTION—ESD: Observe proper electrostatic safety precautions when handling static-sensitive components such as circuit boards and printheads. The discharge of electrostatic energy that accumulates on the surface of the human body or other surfaces can damage or destroy the printhead and other electronic components used in this device. You must observe static-safe procedures when working with the printhead or the electronic components under the top cover.

Close the printer

1. Lower the top cover.
2. Push down on the front of the printer to close.
3. Push the center or both corners of the printer firmly until both side latches lock.



Printer Features

This section will help you identify features of these Zebra® Link-OS 4-inch desktop thermal label printers, the ZD621 and ZD421. 'How to' videos on the Zebra Web site include a Printer Features video; as well as; other printer setup and task specific videos. Links to these five (5) Link-OS 4-inch desktop printers are:

- ZD621 Thermal Transfer Printer — zebra.com/ZD621t-info
- ZD621 Direct Thermal Printer — zebra.com/ZD621d-info
- ZD421 Thermal Transfer Ribbon Cartridge Printer — zebra.com/ZD421c-info
- ZD421 Thermal Transfer Printer — zebra.com/ZD421t-info
- ZD421 Direct Thermal Printer — zebra.com/ZD421d-info
- ZD621R Thermal Transfer Printer — zebra.com/ZD621r-info

Printer Features

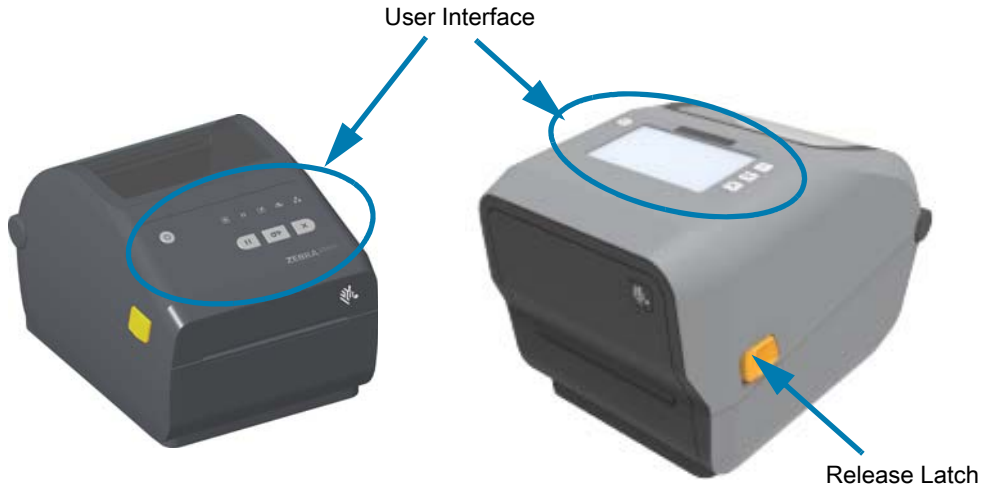

For more details on printer controls, go to [Controls and Indicators on page 37](#).

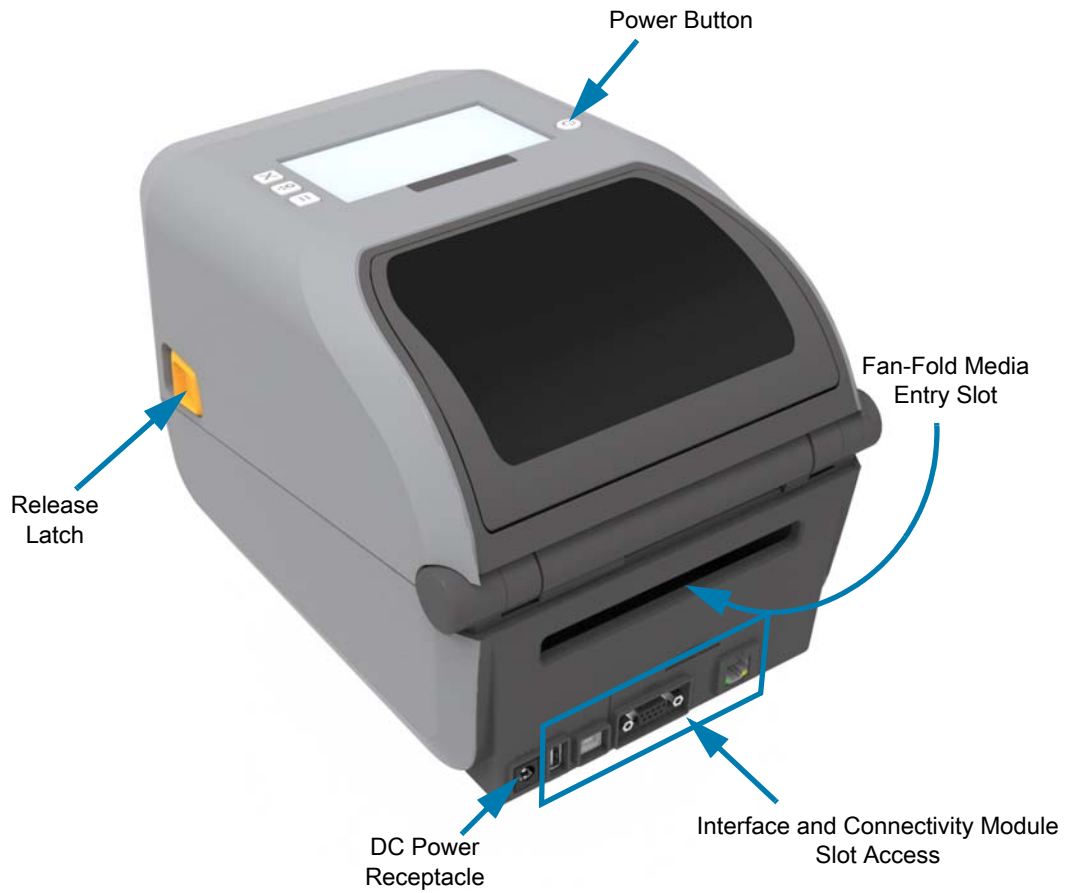

Inside the ZD421 Dual Capacity Ribbon Roll Printer

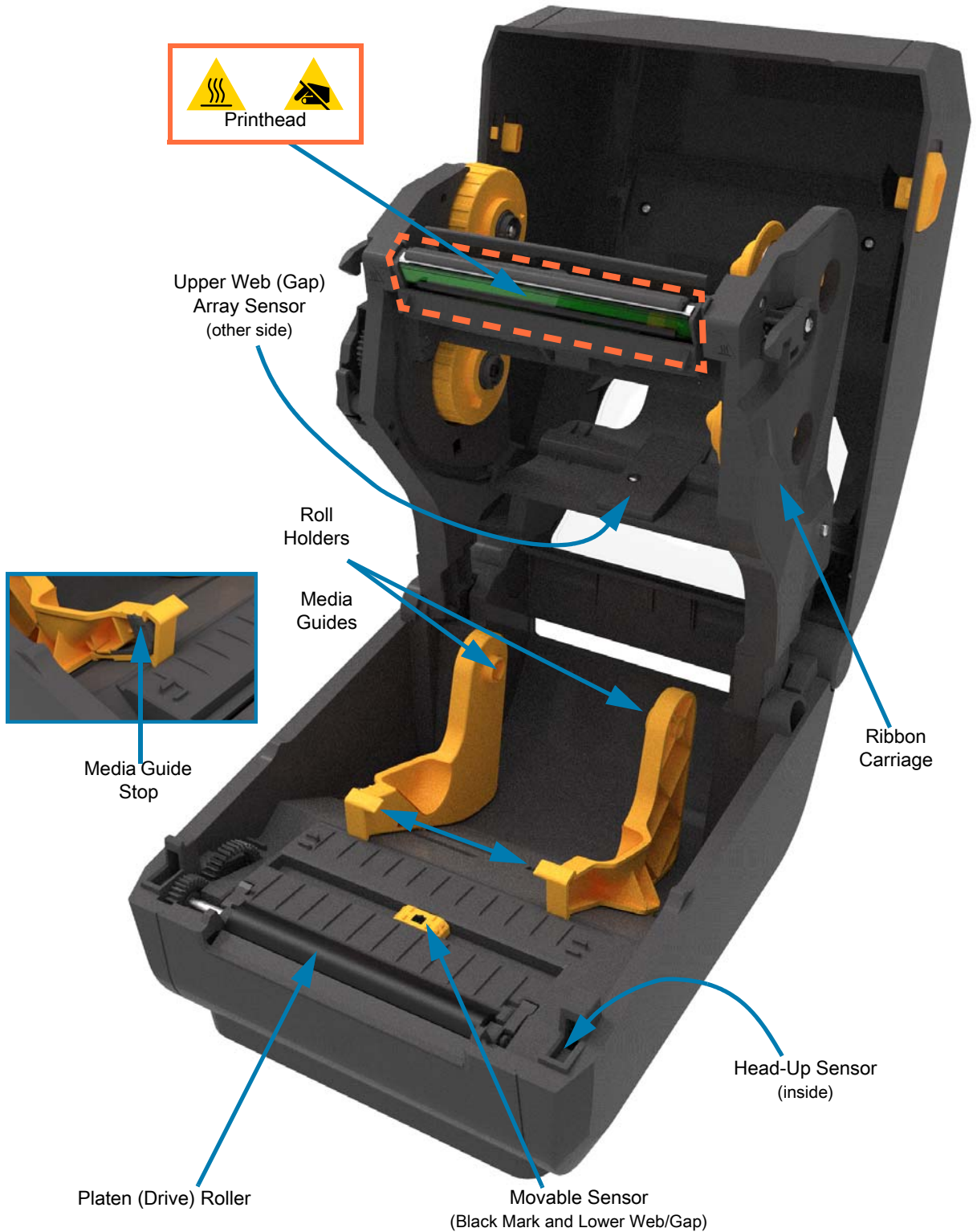

Inside the ZD621 Dual Capacity Ribbon Roll Printer

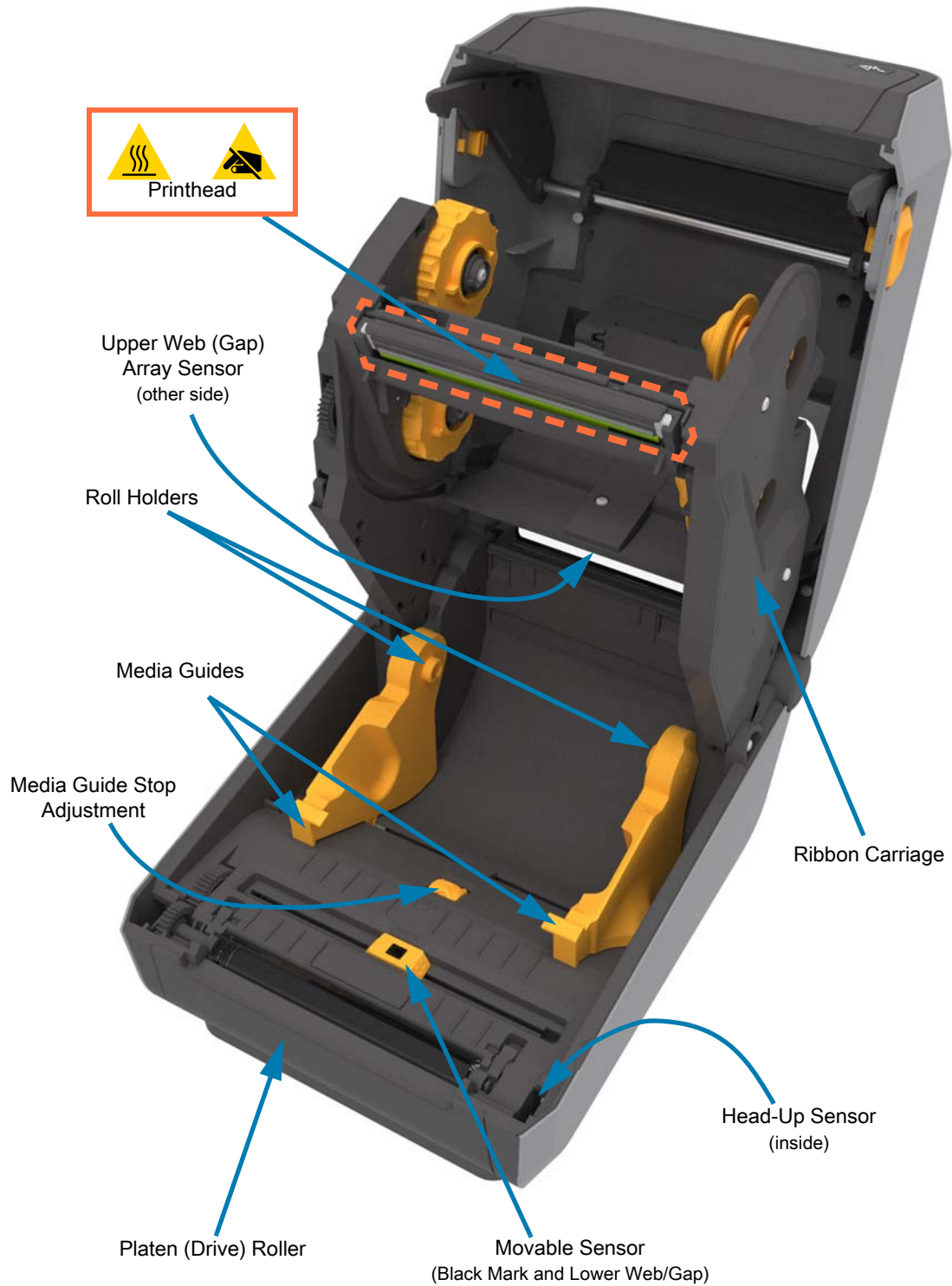

Identifying the ZD621R RFID Antenna Location

The ZD621R printers antenna is located between the platen rollover and movable media sensor channel in the center of the printer. This is the only visible RFID item other than the Color Touch Display when on and the product branding and labeling.



Dual Capacity Ribbon Chassis - Ribbon Roll Holders

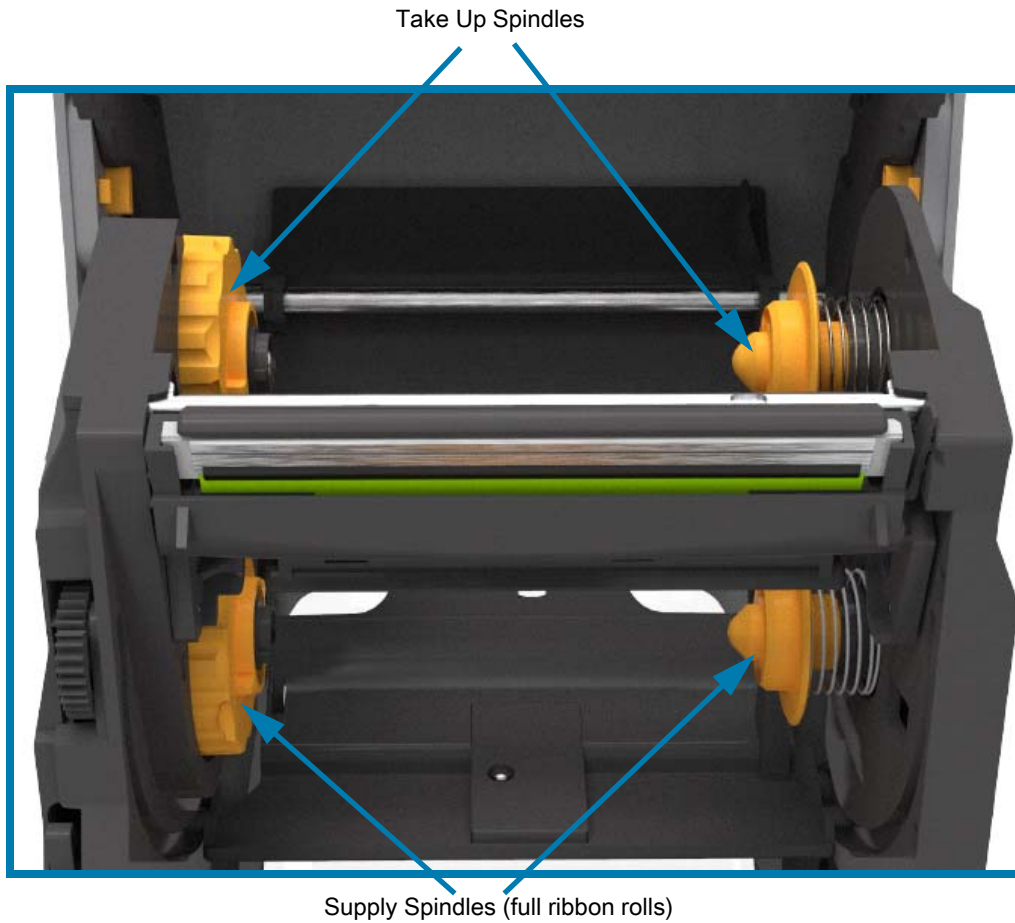

Media Dancer - ZD621 Printer Models Only

The printer's window is removed to show the Media Dancer (plate). The Media Dancer is re-colored to make it easier to locate. It is the same color as the dark gray parts adjacent to it.

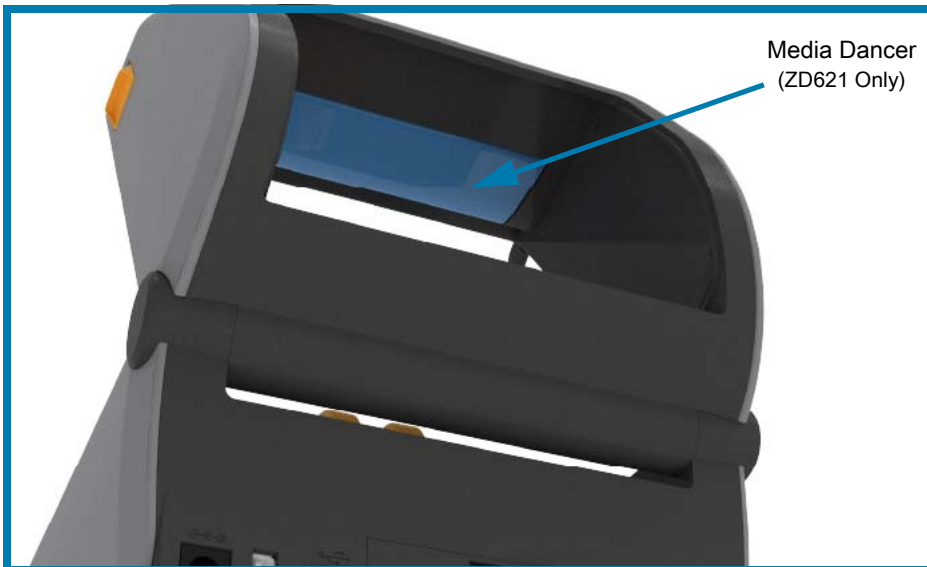

Inside the ZD421 Direct Thermal Printers



Inside the ZD621 Direct Thermal Printers



Inside the ZD421 Ribbon Cartridge Printer



Accessing the Printhead of the Ribbon Cartridge Printer

To access the printhead:

1. Pull both release arms out (lighter gray parts).
The ribbon drive transport drops down.
2. Lift the printhead actuator arm up to access the printhead.

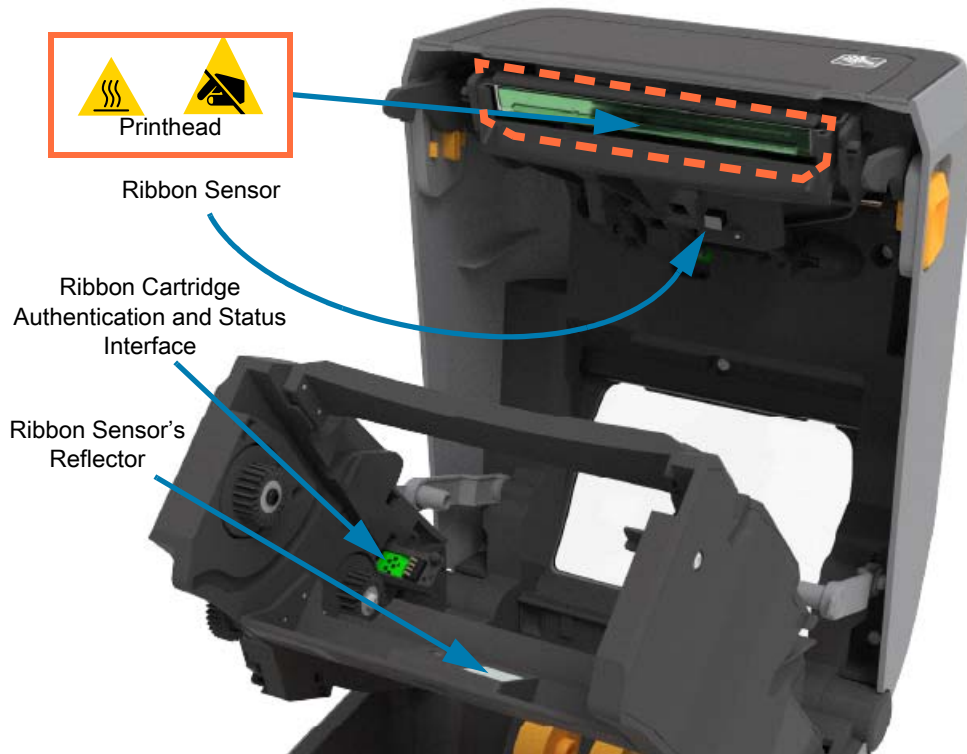

Label Dispenser Option (field installable) - All Models

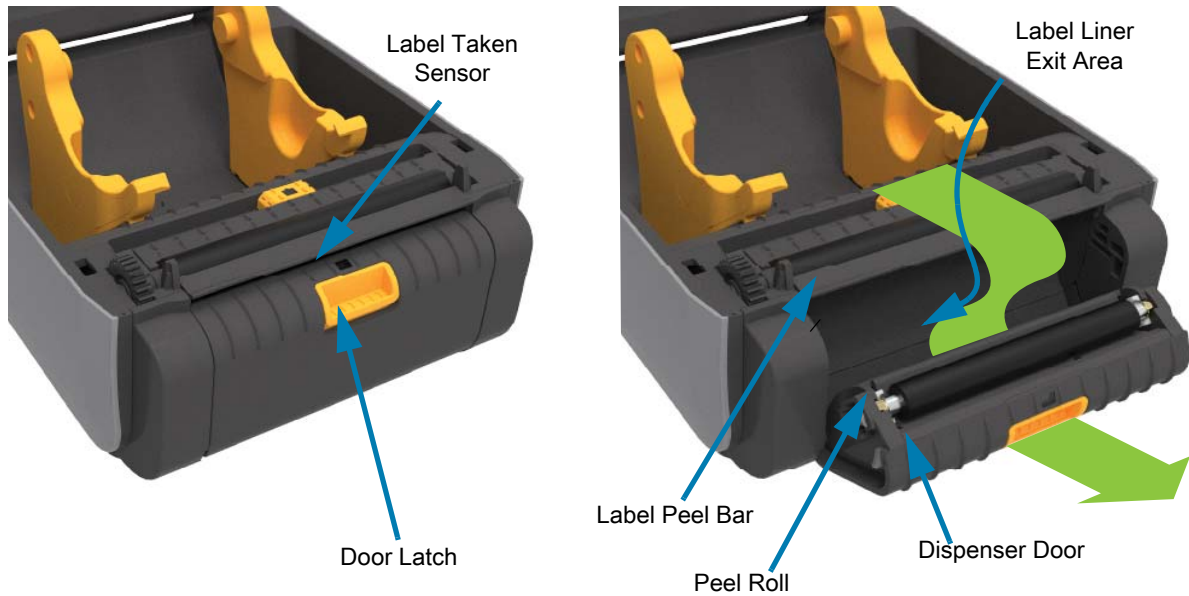

Cutter Option (field installable) - All Models

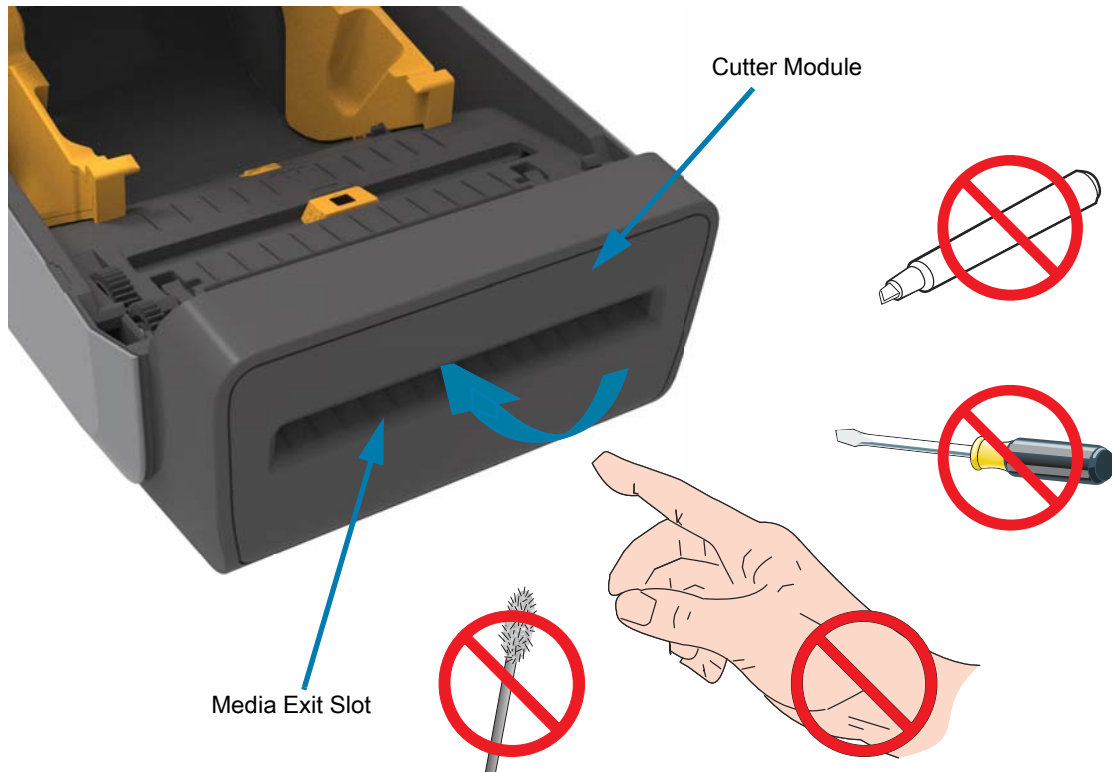

Linerless Media Tear-Off Option (Direct Thermal Models Only)



Linerless Cutter Option (Direct Thermal Models Only)



Identifying Platen Drive Rollers Types

The platen (drive) rollers are colored differently to identify the platen type and print resolution of your printer (and the platen).



IMPORTANT: Do not exchange platen types unless instructed to by an upgrade procedure or Zebra technical support. The printer will not operate correctly and may cause a variety of problems requiring maintenance.

203 dpi Standard Platen (black)



300 dpi Standard Platen (gray)



203 dpi Linerless Platen (reddish-brown)



300 dpi Linerless Platen (brown)



Printer Power Supply Options

ZD-Series printers offer field-installable attached power options: an attached power supply base or a battery power base. These options easily attach with screws and replace the power supply that was included with your printer.

Attached Power Supply Base



Attached Battery Base and Battery

Printer with Battery Base Installed



Battery

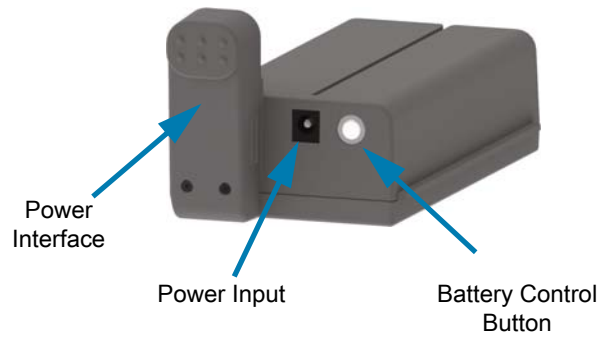

Battery Ready to Install



Printer with Battery installed

Battery Latch



IMPORTANT: The battery can be charged, checked, and configured for storage all without the printer. A printer power supply or other approved Zebra power source is needed to charge your battery.

ZD621 Direct Thermal Locking Printer Features

This option is only available in Direct Thermal Healthcare printer models. It includes a lock and key access to the printer's media compartment and a Kensington Lock Slot on the back panel of the printer to secure the printer. For more information on the Locking Printer option, go to [ZBI 2.0™ — Zebra Basic Interpreter on page 223](#).



Go to [Color Touch Display and Controls on page 68](#) for more information on printer controls.

Zebra Print Touch

The Zebra Print Touch™ feature allows you to touch an Android™ -based, Near Field Communication (NFC)-enabled device such as a smart phone or tablet to the printer's Print Touch logo to pair the device to the printer. Print Touch is available on models with a factory installed networking (Wi-Fi, wired Ethernet, Bluetooth, and Bluetooth Low Power). This capability allows you to use your device to provide information for which you are prompted and then print a label using that information.



IMPORTANT: Some mobile devices may not support NFC communication with the printer until you configure the required NFC settings in your device. If you encounter difficulties, consult your service provider or your smart device manufacturer for more information.



Data encoded into the tag includes:

- A URL for a Zebra QuickHelp style support web page
- The printer's unique Bluetooth Low Energy MAC address
- The printer's Bluetooth Classic MAC address (if present)
- The printer's Wi-Fi (WLAN) MAC address (if present)
- The printer's Ethernet (LAN) MAC address (if present)
- The printer SKU – ex. ZD6A142-301F00EZ
- The printer's unique serial number

The NFC tag can be used to:

- Facilitate Bluetooth pairing with a compatible mobile device.
- Launch an application.
- Launch a mobile browser to a web page.

Controls and Indicators

This section discusses the two user control panel variations and their functionality.

User Interface

The primary user controls are found on the front of the printer. The ZD-Series Desktop printers support two user interface options.

- **Standard User Interface** — This interface provides basic control and status needed by an operator. Printer operating status is reported by five (5) icon indicator lights. The icons represent several functional areas of operation. The indicator lights, as a group, provide a wide range of printer status notifications when used in combination. They are visible from a greater distance than you can read on a printer with a display. Go to [Meaning of the Indicator Light Patterns on page 41](#).
 - This interface supports operator tasks of replacing printing supplies (labels, receipt paper, transfer ribbon, etc.) when prompted by two indicators.
 - Status indicator's icons represent a functional area of printer operation.
 - Status indicator lights typically use color to show the operator the functional status of the printer. The status indicator lights may be off (not lit), red, green, or amber (orange/yellow). Red is 'needs attention' or 'not ready'. Green is for 'ready' or 'functioning'. Amber (orange/yellow) is for busy or active process (data downloading, over-temperature cooling cycle, etc.). An off or un-lit status indicator does not require the operators attention.
 - A status indicator can flash (blink), fade (bright to off), alternate between colors, or remain on in a variety of patterns that denote various printer activities, and operational status as a group.
 - Control buttons are used in various combinations to access internal utilities that calibrate the printer to your media and make limited print settings.
- **Color Touch Display and Interface** — The Color Touch Display interface provides easy access to printer setup, configuration, and is customizable for all user types. The interface includes all the Standard User Interface controls and indicators to provide you with common functionality and behaviors for these Link-OS printer models.
 - The display option provides written printer status and messages.
 - The display supports 19 languages, selectable by the operator, or with programming.
 - It has a menu system. Users can make changes to print settings (darkness, speed, etc.), run utilities, and set wired and wireless communication interfaces (Serial, Ethernet, Wi-Fi, etc.) that are installed on your printer.

Standard Interface Controls

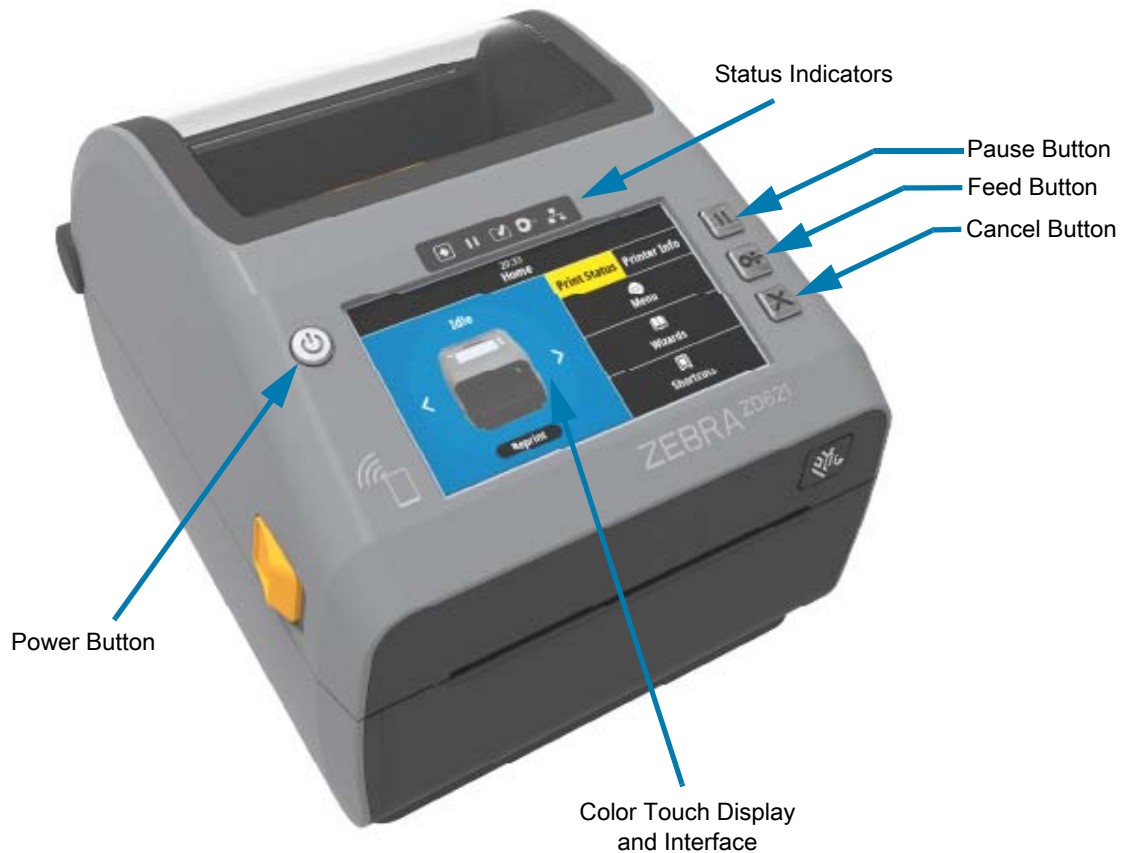
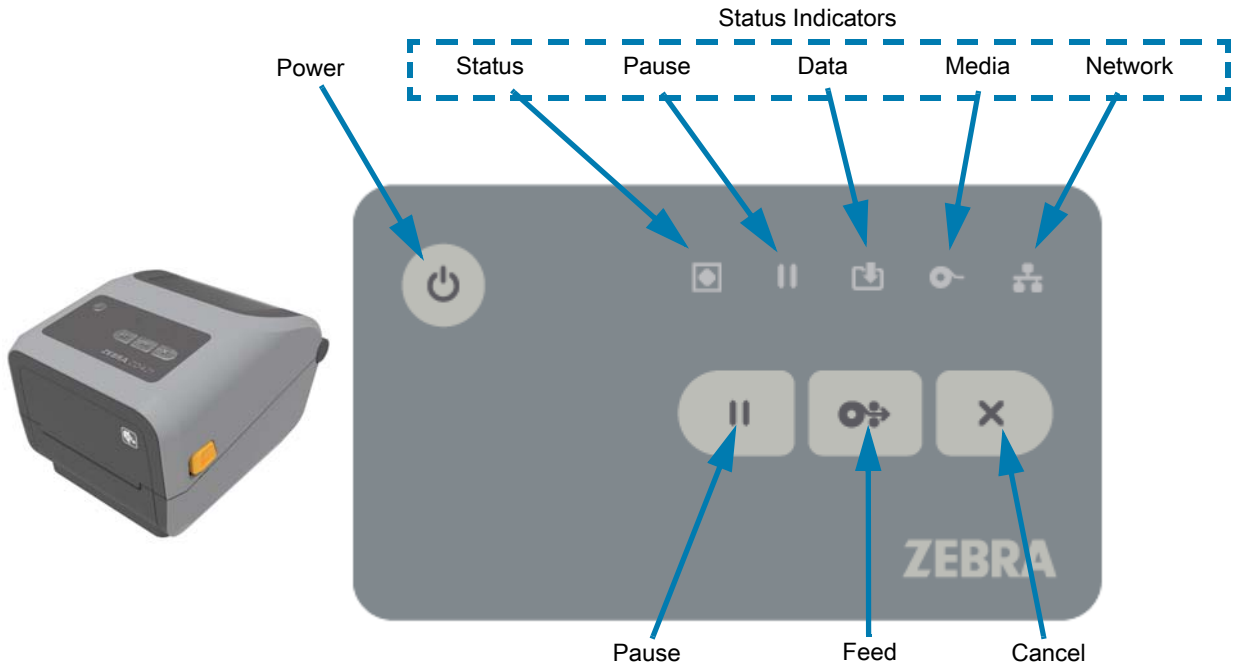



1. Power Button — Turns power ON and OFF in the printer. It is also used to initiate low-power sleep and wake states.

- Initial Power ON — Press the Power button until the printer's indicator lights flash on. The indicator lights will flash on and off in various combinations while the printer does self diagnostics, configuration checks, and integrate optional components which will take several seconds to complete.

The Status indicator will turn solid GREEN indicating the printer is ready for normal print operations.

- Energy Star (Low Power Mode) — Pressing and releasing the button once will cause the printer to enter Energy Star low power mode. The printer will minimize power use. All the indicators will be off except the Status Indicator will slowly change between On and Off to indicate Energy Star Mode.
- Power OFF with Energy Star Delayed — Press and Hold the button for 4-9 seconds. The operator can start a batch print job and put the printer into the low power consumption state of Sleep mode — after the job has finished.
- Power OFF / Shutdown — Press and Hold the button for 4-9 seconds. The printer will turn OFF.
- Power Failure Recovery Mode — This printer feature is activated by a hardware jumper setting on one of the optional Printer Connectivity Modules installed in the printer. Go to [Setting the Power Failure Recovery Mode Jumper on page 224](#).
 - The printer will automatically Power ON when plugged into an active (ON) AC power source.
 - Supports Sleep Mode and Power OFF with Sleep mode Delayed.
 - A Power OFF/Shutdown will reset the printer and then runs the Initial Power ON sequence.



NOTE: The Power Failure Recovery Mode is only available on printers with a Printer Connectivity Module installed in the printer.



2. Status Indicator — Primary status indicator for overall printer health and operational status. This indicator is also known as the Power indicator.

- Green: Ready for print and data activity.
- Green, Slowly Changing between ON and OFF: Printer is in Sleep Mode.
- Red: Media out, media detection error, head (cover/printhead) open, cut error, printhead authentication failure.
- Amber: Printhead Over Temp (temperature), printhead element failure, out of memory while storing content (formats, graphics, fonts, etc.), and interface power fault for USB Host or Serial ports.
- Blinking Amber: Printhead Under Temp (temperature)
- Blinking Red: Printhead Over Temp (temperature) — this status is coupled with blinking red Pause indicator. Requires cooling and printer restart.



3. Pause Indicator — The printer is in Pause mode when the Pause indicator light is on. A label (print form) or all labels (print forms) in the print buffer's queue can be canceled when the Pause indicator is on using the Cancel button.

- Amber: The printer is paused. Print, label FEED (advance), and other label routines are suspended until the pause state is removed by pressing the Pause button.
- Blinking Red: Printhead Over Temp (temperature) — this status is coupled with blinking red Status indicator. Requires cooling and printer restart.



4. Data Indicator — Indicates the status of data transfer activity.

- Off: Data is not being transferred.

- Green: A data communication operation has not finished, but is not actively being transferred.
- Blinking Green: Data communications are in process.
- Blinking Amber: Out of memory while storing content (formats, graphics, fonts, etc.).



5. Supplies Indicator — Indicates media (label, receipt, tags, transfer ribbon, ribbon cartridge, etc.) status.
 - Red: There is a media out condition.
 - Blinking Red: Ribbon Out.
 - Blinking Red and Amber: Ribbon Cartridge Low (ZD421 Cartridge printers only).
 - Blinking Amber: Ribbon In (ZD421 Cartridge printers only) detected while the printer is attempting to print in direct thermal mode.



6. Network Indicator — Indicates network activity and status.
 - Amber: 10 base Ethernet (LAN) connection detected.
 - Green: 10/100 Ethernet (LAN) connection detected or when Wi-Fi (WLAN) has a strong signal and is connected.
 - Red: when an Ethernet (LAN) or Wi-Fi (WLAN) fault occurs.
 - Blinking Red: during Wi-Fi (WLAN) association.
 - Blinking Amber: during Wi-Fi (WLAN) authentication.
 - Blinking Green: when Wi-Fi (WLAN) has completed, but has a weak signal.



7. Cancel Button — Cancels print jobs.
 - Only functional when the printer is in the Pause state.
 - Pressing the Cancel button once causes the printer to cancel printing the next format in the print buffer.
 - Pressing and holding the button for two seconds cancels printing of ALL pending formats.



8. FEED (Advance) Button — Advance a label (print form/format).
 - Feed One Label - Pressing (and releasing) the FEED button when the printer is not printing, causes the printer to advance media one (1) blank form/format length (label, receipt, tag, ticket, etc.).
 - Advance Multiple Labels - Pressing and Holding the FEED button when the printer is not printing, causes the printer to advance labels until released. It finishes advancing to the beginning position of the next label.
 - Reprint Last Label (activated via a SGD command: `ezpl.reprint_mode`) - The intended purpose of this feature is to allow reprint of a failed media print. If the printer runs out of media (paper, labels, transfer ribbon, etc.), then the printer can re-print the last label (print form/format). The print buffer that stores the print image available for reprint is cleared when the printer gets turned off or is reset.



9. Pause Button — Pauses print and media movement actions.
 - Pressing the Pause button will stop print activities and place the printer into a 'Pause' state. The printer will complete printing a label that is printing before it pauses.
 - The Pause indicator will display Amber (orange/yellow) to indicate the Pause state.
 - Pressing the Pause button while in Pause state will return the printer to normal operation. If printing a multi label (form/format) job or another print job is waiting to print in the print queue, then printing will resume print jobs.

Meaning of the Indicator Light Patterns

All of the Link-OS 4 inch printers have status indicators. The indicators may be off or on in a variety of lighting patterns of red, green, or amber (orange/yellow). The status indicators can flash (blink), fade (bright to off), alternate between colors, or just remain on. The status information that these lighting patterns represent is detailed in this section.

Indicator States

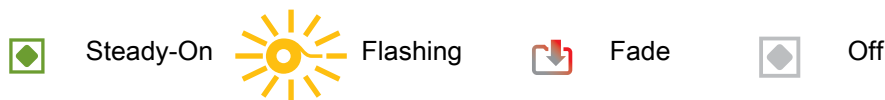

Status - Typical Operating Conditions

Printer Ready



The printer is powered on and ready to print.

Pause



The printer is paused. The operator must press the Pause button to resume print operations.

Media Out



The media (labels, receipts, tags, tickets, etc.) supply is out. The printer needs attention and cannot continue without user intervention.

Ribbon Out

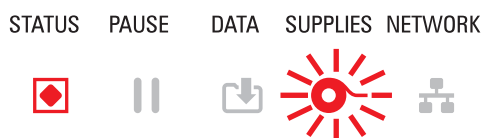

Detected end of ribbon roll (reflective end on ribbon rolls), a missing ribbon cartridge, or the ribbon cartridge needs replaced to continue printing when the printer is in thermal transfer mode.

Ribbon Low (Ribbon Cartridge Printers Only)

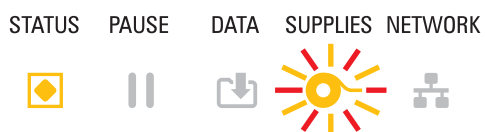

Default value is 10% of ribbon remaining. The Media indicator flashes red and yellow while the Status indicator is solid yellow.

Ribbon In (Ribbon Cartridge Printers Only)

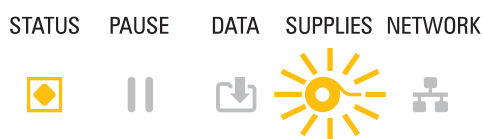

Thermal Transfer printer is in Direct Thermal Mode and has a ribbon cartridge installed. Remove the ribbon cartridge to continue printing in direct thermal mode.

Transferring Data

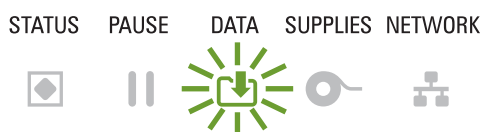

Data communications are in process.

Data Transfers Paused



A data communication operation has not finished, but is not actively being transferred.

Out of Memory

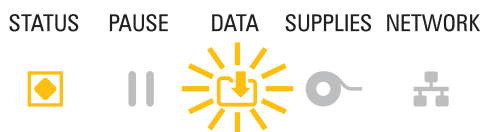

Out of memory while storing content (formats, graphics, fonts, etc.).

Cover Open/Printhead (PH) Open



The cover (printhead) is open. The printer needs attention and cannot continue without user intervention.

Cut Error (Binding)



The cutter blade is bound and is not moving properly.

Cartridge Authentication Failed



The ribbon cartridge can not be authenticated or has been altered. The printer only supports Genuine Zebra Ribbon Cartridges and does not support refurbished or non-Zebra cartridges.

Status - Printhead Operation



Hot Surface Caution • The printhead may be hot and could cause severe burns. Allow the printhead to cool.

Printhead Over Temp



The printhead is over temperature and paused to allow the printhead to cool. The print operation will resume after the printhead has cooled.

Printhead Under Temp

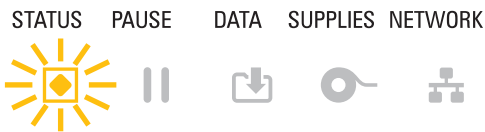

The printhead is under temperature. Typically, the operating environment is below the printer's minimum operational temperature.

Printhead Shutdown

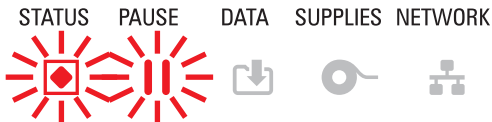

The printhead is over temperature. **Turn the printer OFF.** After several minutes to allow the printer to completely cool, turn the printer ON.

Printhead Resolution Error



The printer is unable to read the printhead resolution type (dpi). The printhead has been replaced incorrectly or with non-Zebra printhead.

Unauthorized Printhead Error



The printhead was replaced with one that is not a genuine Zebra printhead. Install a genuine Zebra printhead to continue.

Status - Bluetooth Low Energy (BTLE) Option

Bluetooth LE Paired

STATUS PAUSE DATA SUPPLIES NETWORK Bluetooth Low Energy has paired.











Bluetooth LE Failed to Pair





STATUS PAUSE DATA SUPPLIES NETWORK Bluetooth Low Energy has failed to pair.

Status - Ethernet (LAN) Option

Ethernet (LAN) No Link

STATUS PAUSE DATA SUPPLIES NETWORK No Ethernet link is available. **NETWORK status is light off**

Ethernet (LAN) 100base Link

STATUS PAUSE DATA SUPPLIES NETWORK A 100 Base link was found.







Ethernet (LAN) 10base Link

STATUS PAUSE DATA SUPPLIES NETWORK A 10 Base link was found.











Ethernet (LAN) Link Error

STATUS PAUSE DATA SUPPLIES NETWORK An error condition exists. The printer is not connected to your network.

Status - Wi-Fi (WLAN) Option

Wi-Fi Connecting to WLAN

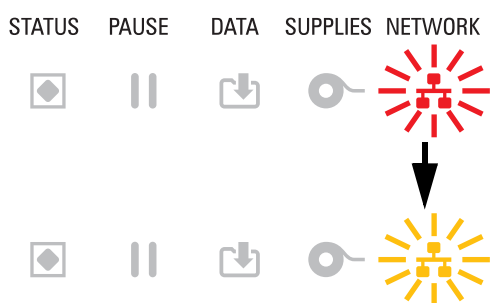

The light flashes red while the printer associates with the network.

The light then flashes yellow while the printer is authenticating with the network.

Wi-Fi (WLAN) 100base Link



The printer is connected to your network and the **Wi-Fi signal is strong.**

Wi-Fi (WLAN) 10base Link



The printer is connected to your network and the **Wi-Fi signal is weak.**

Wi-Fi (WLAN) Link Error



An error condition exists. **The printer is not connected to your network.**

Battery Indicators and Controls

The optional printer battery accessory has a simple, one button, 4 LED indicator light user interface to control and display battery status and health. The battery acts as a UPS (uninterruptible power supply) for the printer. For more information on using the battery with your printer and power saving modes (Sleep, Shutdown, etc.), go to [Printing with the Attached Battery Base and Battery Option on page 219](#).

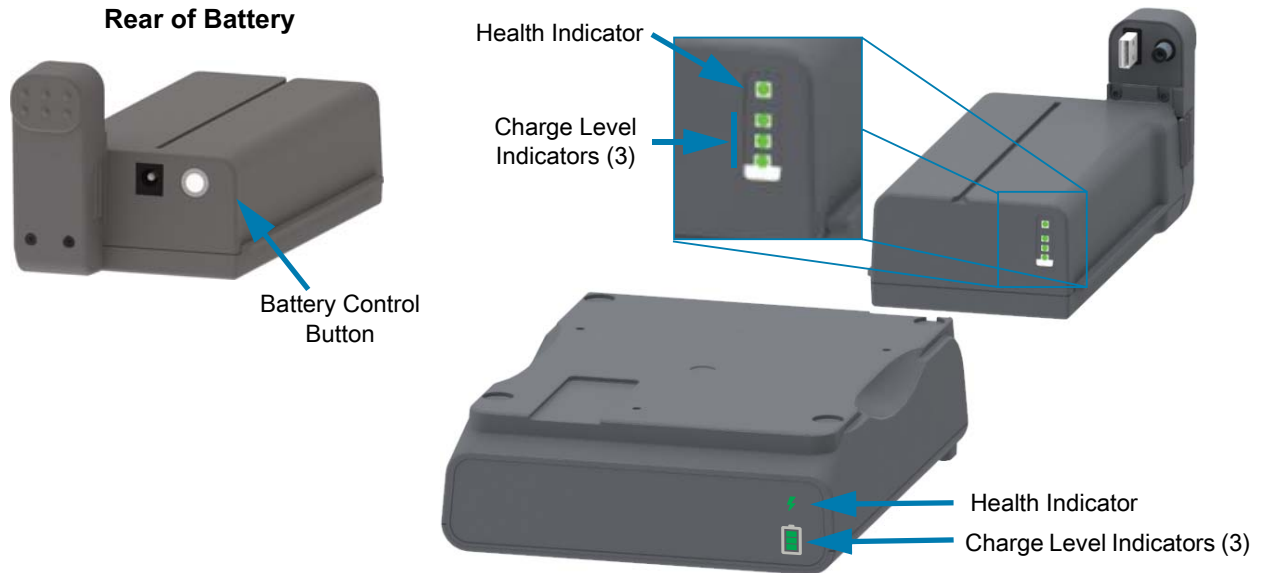

Battery Control Button — The button helps you control the battery, both inside and outside of the printer.

- **Battery On** - Press and release
 - Wakes up (activates power) the battery from Sleep or Shutdown Modes. The battery health and charge status are checked. The battery indicators all flash on and off together 3 times. The operator now has one (1) minute to turn the printer on before the battery reverts back to the previous Sleep or Shutdown Mode.
 - Battery displays the battery level charge during the first ten (10) seconds after internal battery health checks are complete
 - **Shutdown Mode** - Press and hold the button for 10-11 seconds and release. The battery begins shutdown and approximately 3 seconds later all of the battery LEDs will flash three (3) times to let you know the battery has shut down.



Battery Health Indicator — Displays the battery's charging status and health of the battery.

- Green - Good health, charge complete and ready to operate.
- Amber - Charging (printer is OFF).
- Red - Battery has an internal error. Remove the battery and go to [Troubleshooting on page 274](#).
- Flashing Red - Charging error - over or under temperature, internal monitoring error, etc.



Battery Charge Level Indicator — Displays the battery's charging status and health of the battery.

- Three green bars on, no flashing - Battery is fully charged. (The battery will not start charging)
- Two green bars on with the top bar flashing. Less than full charge.
- One green bar flash - Time to charge your battery!
- No bars on - Battery needs charging, but the Battery Health Indicator flashes when the Battery Control Button is pressed. The printer can not be turned on.
- Amber - Charging.

Install Hardware Options

This section assists you installing common printer connectivity modules and media handling options.



IMPORTANT: To simplify and speed up the setup process, install all connectivity modules and media handling options before setting up and using your printer for the first time.



IMPORTANT: It is strongly recommended that you update your printer's firmware after the printer has completed the setup process. Many of these options have internal firmware that require an update to operate properly with the printer's Main Logic Board's installed firmware version.

Field Installable printer Accessories and Options

Printer Connectivity Modules

The connectivity module's access door must be removed prior to installing the following options — [Accessing the Connectivity Module Slot on page 49](#).

- Wireless Connectivity Module — go to [Installing the Wireless Connectivity Module on page 53](#).
 - Wi-Fi 802.11ac, Bluetooth 4.2, BTLE 5, and MFi 3.0
- ZD421 Serial Port — go to [Installing the Serial Port Module on page 50](#)
 - RS-232 DB-9 connector with DTE/DTC auto-switching — go to [Serial Port Interface on page 308](#)
- ZD421 Internal Ethernet (LAN - wired) — go to [Installing the Internal Ethernet \(LAN\) Module on page 51](#)
 - RJ-45 connector
 - Fast Ethernet 10/100 auto-switching, 10Base-T, and 100Base-TX networks.

Media Handling Options

The printer's standard bezel must be removed prior to installing the following options — go to [Removing the Standard Bezel on page 56](#).

- Label Dispenser (Peel-Off Liner and Present Label for Operator) — go to [Installing the Label Dispenser on page 57](#).
- General Purpose Media Cutter — go to [Installing the Standard Media Cutter on page 58](#).
- Linerless Media Cutter — go to [Installing the Linerless Media 'Tear-Off' Bezel on page 60](#).
- Linerless Media 'Tear-Off' Label Bezel — go to [Installing the Linerless Media 'Tear-Off' Bezel on page 60](#).

- Printer Resolution Upgrade Kits (203 dpi and 300 dpi) — go to [Print Resolution Upgrade Kits on page 63](#).
- Media Roll Adapters for 38.1 mm (1.5 in.), 50.8 mm (2.0 in.), or 76.2 mm (3.0 in.) I.D. media cores - go to [Media Roll Core Size Adapters on page 61](#).
- Fan-Fold Media Access Cover for thermal transfer printers.

Power Base Options

The ZD-Series (ZD621 and ZD421) printers are supported with power base field upgrade kits for each the direct thermal and thermal transfer versions of these printers.

- Attached Power Supply Base (power supply included) — go to [Installing the Attached Power Supply Base Options on page 64](#).
- Battery Power Base (battery pack sold separately) — go to [Installing the Attached Battery Base Options on page 66](#).
- Battery Pack (battery power base sold separately) — go to [Installing the Battery into the Attached Power Base on page 67](#).

Printer Connectivity Modules

The connectivity modules can be easily installed without tools.



CAUTION—ESD: The discharge of electrostatic energy that accumulates on the surface of the human body or other surfaces can damage or destroy the printhead or electronic components used in this device. You must observe static-safe procedures when working with the printhead or the electronic components.

Power Failure Recovery Mode Jumper (OFF by Default)

All of the Printer Wired Connectivity Modules have a Power Failure Recovery jumper. It is set to the OFF position by default. With the jumper set to ON, the printer will automatically Power ON when plugged into an active (ON) AC power source (and not power off). Go to [Standard Interface Controls on page 38](#) - Power Button - Power Failure Recovery Mode for power ON/OFF behaviors. Go to [Setting the Power Failure Recovery Mode Jumper on page 224](#) for instructions on activating the mode.



NOTE: The Power Failure Recovery Mode is only available on printers with a Printer Connectivity Module installed in your printer.

Accessing the Connectivity Module Slot

1. Disconnect the DC power plug from the rear of the printer.
2. Push down on the top of the module access door with your finger tip.
The latch released.
3. Pull the door away and down to remove it.

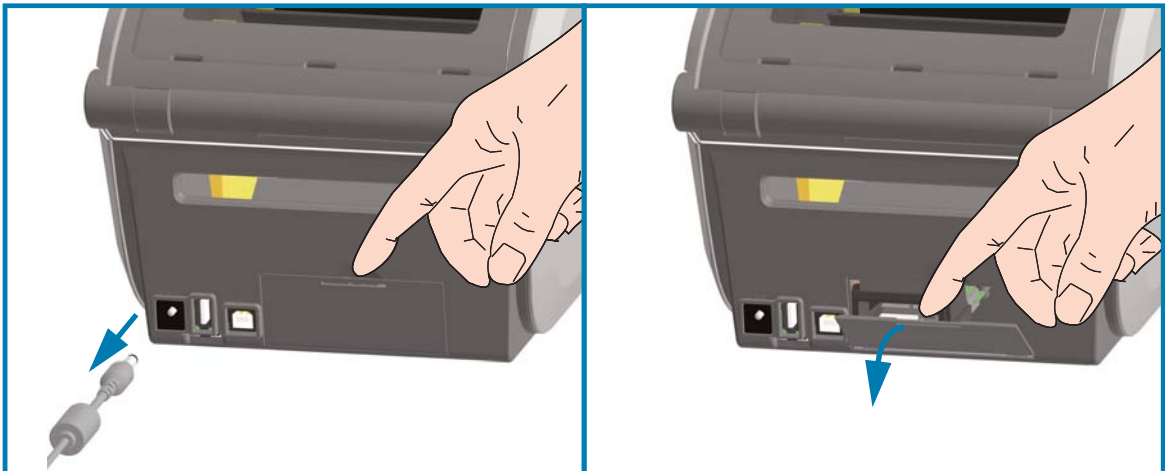

Installing the Serial Port Module



1. With the DC power plug and module's access door removed, slide the serial port module into the printer.
2. Push the circuit card in slowly but firmly until the card is just past the inside lip of the access door.
3. Align the bottom of the serial port's door cover to the bottom lip of the module access opening.
4. Swing the door up and snap the cover closed.



NOTE: For best printer performance, update the printer's firmware after installing options or immediately after the printer's initial setup. Go to [Updating Printer Firmware on page 273](#).

Installing the Internal Ethernet (LAN) Module



1. With the DC power plug and module's access door removed, slide the Ethernet module into the printer.
2. Push the circuit card in slowly but firmly until the card is just past the inside lip of the access door.
3. Align the bottom of the Ethernet port's door cover to the bottom lip of the module access opening.
4. Swing the door up and snap the cover closed.



NOTE: For best printer performance, update the printer's firmware after installing options or immediately after the printer's initial setup. Go to [Updating Printer Firmware on page 273](#).

Removing Printer Connectivity Modules

Connectivity modules can be removed to reconfigure or repair a printer. You should not remove and replace connectivity modules as a general practice.

1. Remove the interface cable (Ethernet or Serial).
2. Remove the module access door. Push down on the top of the door with your finger tip.
The latch released.
3. Pull the door away and down to remove.
4. Reattach the interface cable to the connectivity module and secure the cable.
5. Gently pull on the interface cable that is secured to the connectivity modul, and slowly pull the module out of the printer.
6. Install a different connectivity module or reinstall the connectivity module's access door.
7. Align it to the bottom lip of the access opening and swing it up to snap and lock in place.

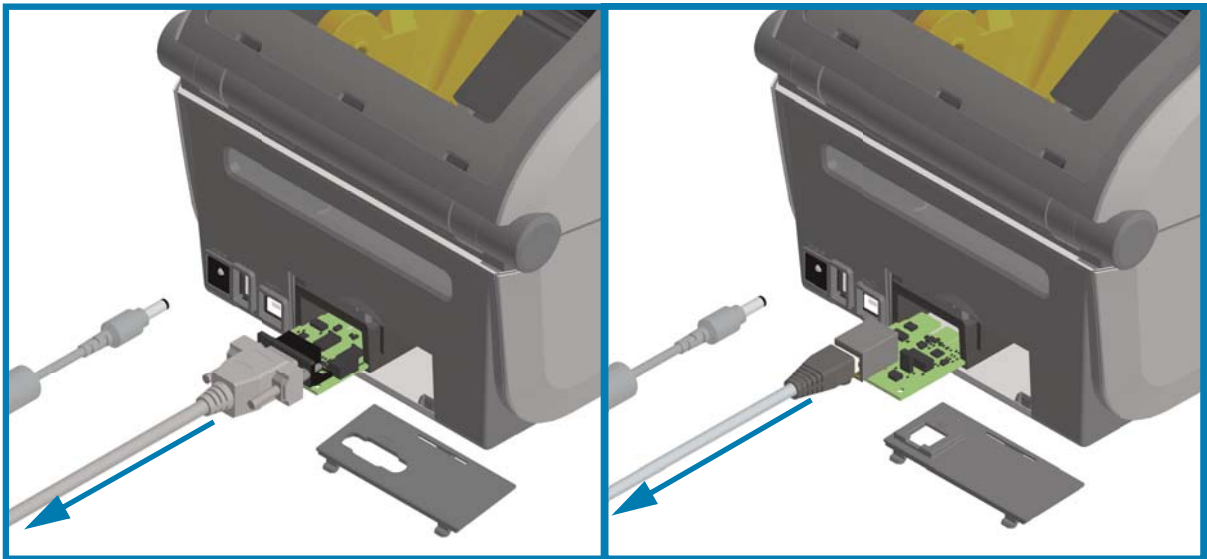

Installing the Wireless Connectivity Module

Use this procedure to install the Wireless Connectivity Module.



CAUTION—ESD: The discharge of electrostatic energy that accumulates on the surface of the human body or other surfaces can damage or destroy the printhead or electronic components used in this device. You must observe static-safe procedures when working with the printhead or the electronic components.

Installation Preparation

1. Unload printer media.
2. Turn OFF the printer.
3. Disconnect any power or interface cables from the printer.



NOTE: No tools are needed for this procedure.

Access the Wireless Connectivity Area

1. Turn the printer over to access the Wireless Connectivity Door.
2. Push the latch at the top with your fingertip to open the module access door.
The printer base has a recessed area for your fingertip. The latch released.
3. Lift and swing the door up to remove it.



4. Align the antenna arm (1) into the well.
5. Lower and align the module (2) to the printer's Wi-Fi connector (3).
6. Push the module (2) in gently but firmly until fully seated.



7. Align the shortest side of the Wireless Connectivity Door (1) to the shortest side of the opening.
8. Swing the door on the tab (1) in the middle of the door printer and swing the door closed.
9. Push the door to lock the latch.



NOTE: The Wireless Connectivity Door will not close correctly if the module has not been fully seated. This is a good test to verify complete insertion.

5. Place the three (3) Wi-Fi identification labels included on the bottom of the printer.

These assist with printer configuration (and later reconfiguration) of your printer. Mobile apps, use of scanners, and printer support are aided by these printer configuration labels.

Label Locations for Thermal Transfer Printers

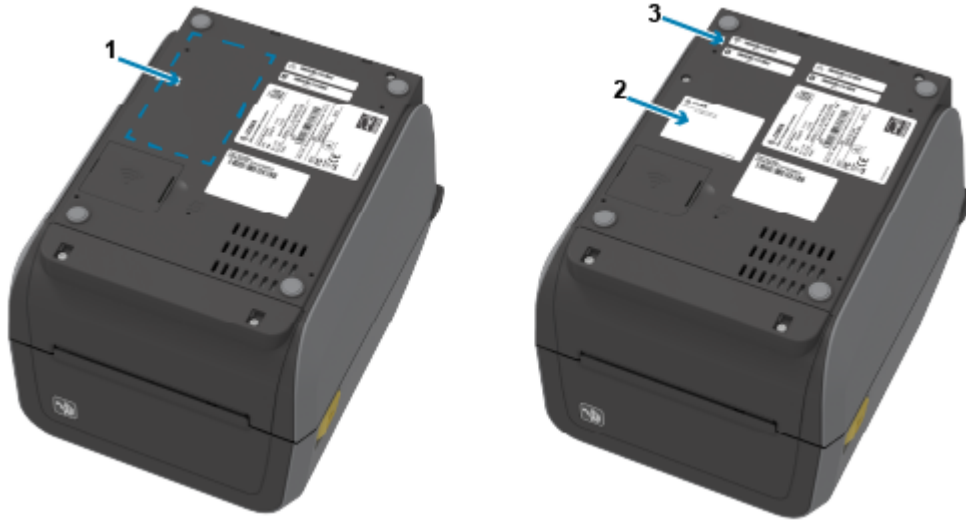

Label Locations for Direct Thermal Printers



Media Handling Options



CAUTION—ESD: The discharge of electrostatic energy that accumulates on the surface of the human body or other surfaces can damage or destroy the printhead or electronic components used in this device. You must observe static-safe procedures when working with the printhead or the electronic components.

Removing the Standard Bezel

The standard bezel must be removed to mount your media handling option.

1. Disconnect the printer's DC power input plug from the rear of the printer.
2. Turn the printer upside down. Remove the two (2) mounting screws with the supplied T10 wrench. Save the screws.
3. Slide the bezel down the front about 12.5 mm (0.5 in.) and pull the loose bezel out.

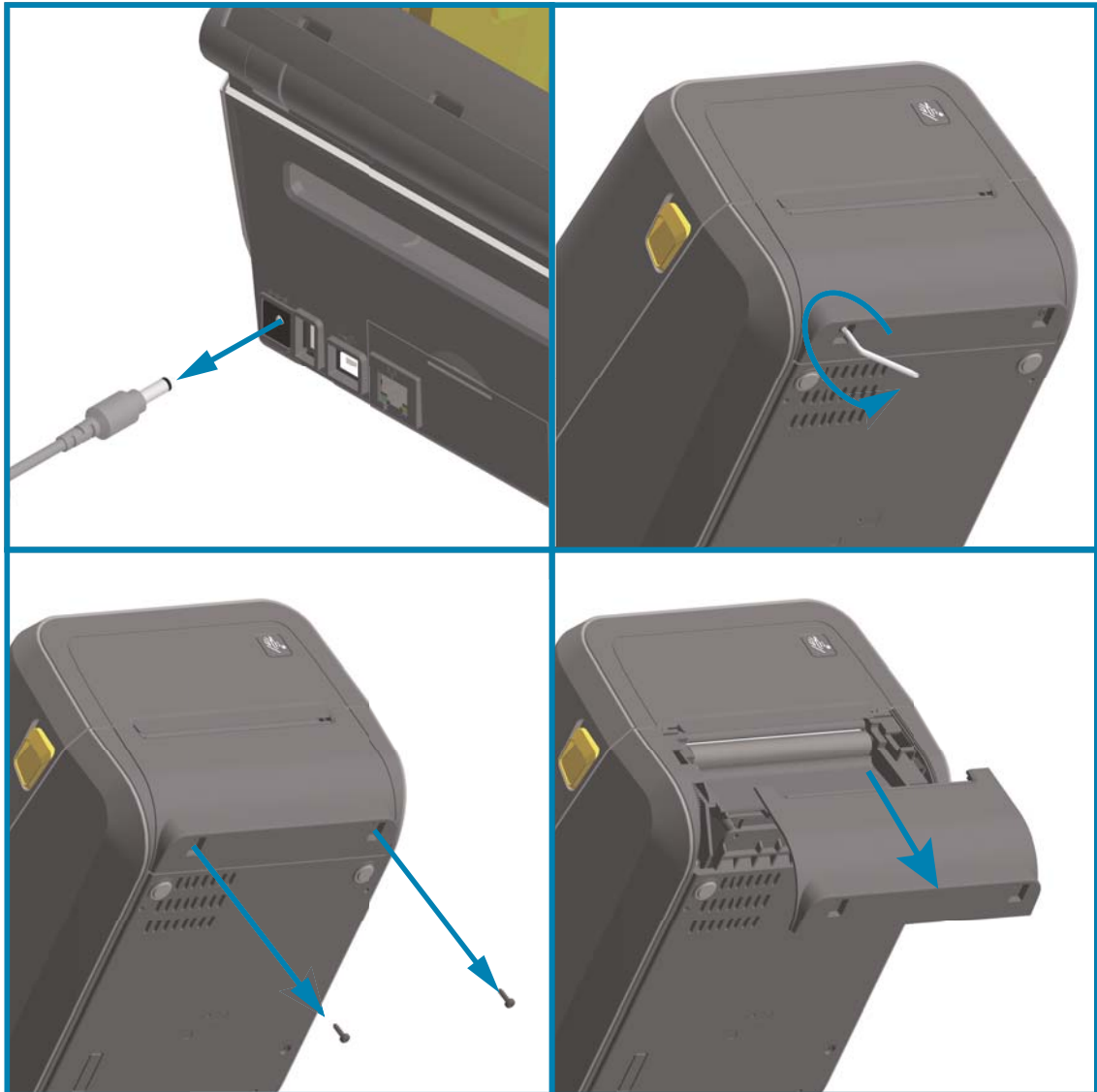

Installing the Label Dispenser

The standard bezel must be removed and DC input power disconnected before the Label Dispenser can be installed. Go to [Removing the Standard Bezel on page 56](#).

1. Place the label dispenser module and printer right side up with the top of the module 12.5 mm (0.5 in.) below the bottom of the top cover.
2. Center and push the module into the front of the printer and slide it up until it stops.
3. Turn the printer upside down and attach the module to the printer with the two screws using the T10 wrench.

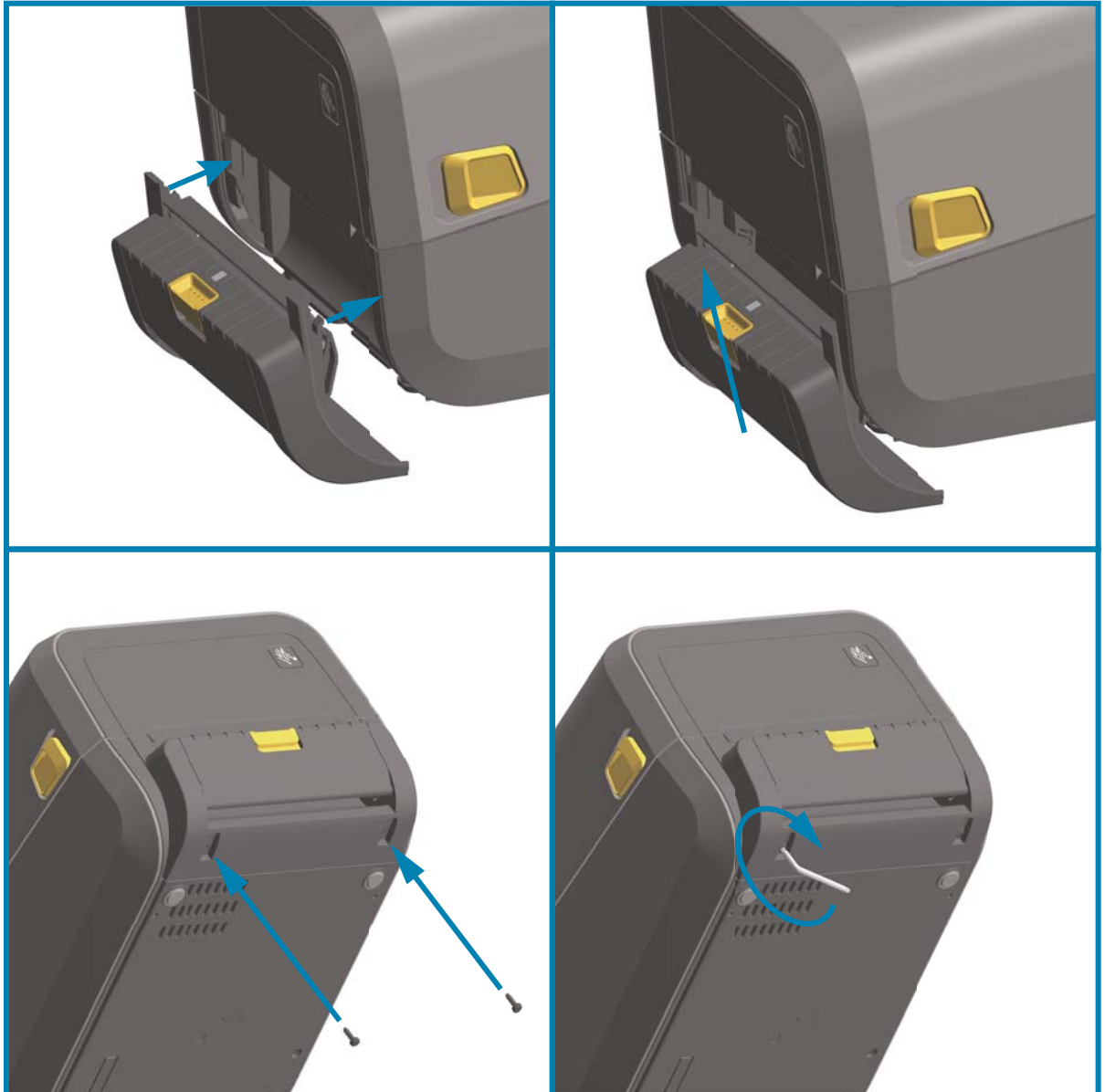

NOTE: For best printer performance, update the printer's firmware after installing options or immediately after the printer's initial setup. Go to [Updating Printer Firmware on page 273](#).

Installing the Standard Media Cutter

The standard bezel must be removed and DC input power disconnected before the Label Dispenser can be installed. Go to [Removing the Standard Bezel on page 56](#).



CAUTION: There are no operator serviceable parts in the cutter unit. Never remove the cutter cover (bezel). Never attempt to insert objects or fingers in to the cutter mechanism.



IMPORTANT: Using un-approved tools, cotton swabs, solvents, etc. all may damage or shorten the cutter's usable life or cause the cutter to bind.

1. Place the Cutter module and printer right side up with the top of the module even with the bottom of the top cover.
2. Center and push the module into the front of the printer and slide it up until it stops.
3. Turn the printer upside down and attach the module to the printer with the two screws using the T10 wrench.

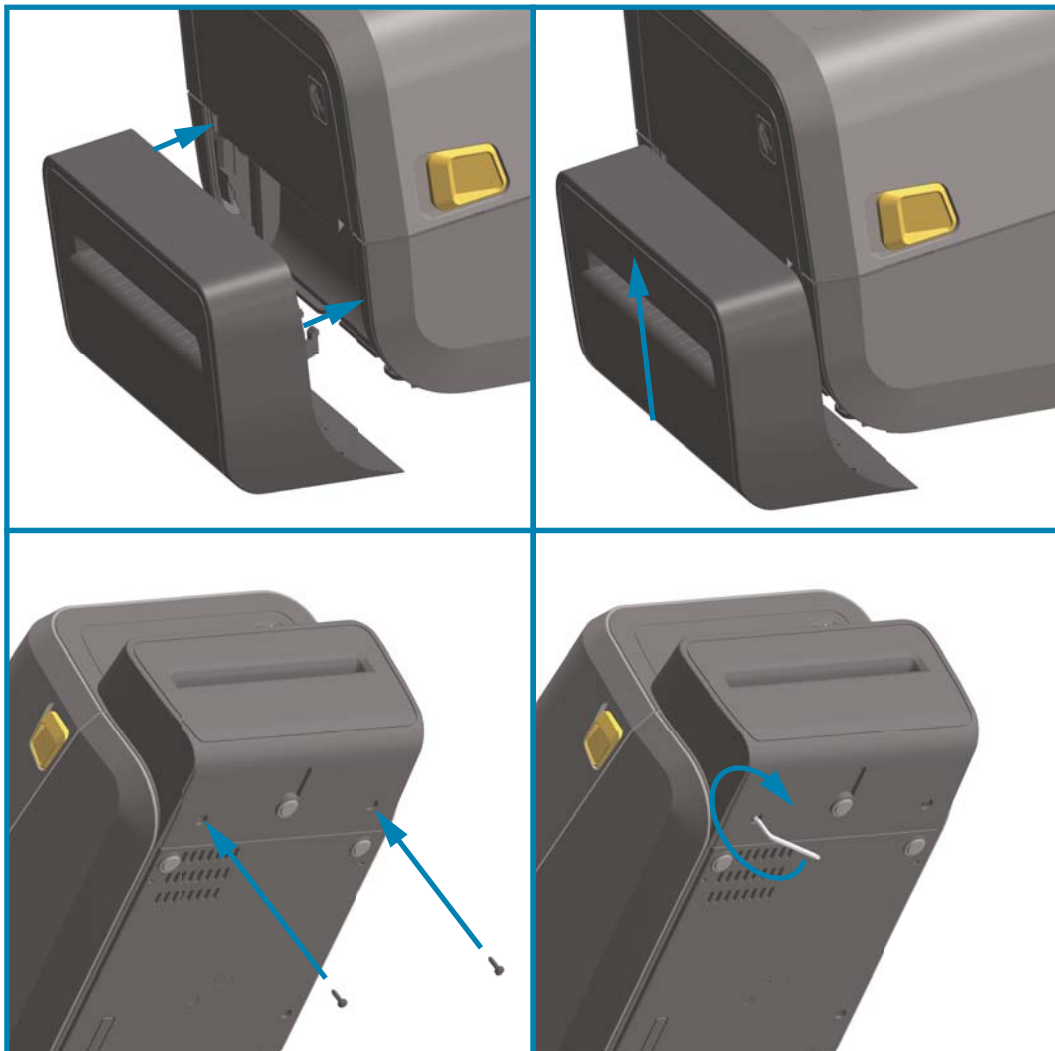

NOTE: For best printer performance, update the printer's firmware after installing options or immediately after the printer's initial setup. Go to [Updating Printer Firmware on page 273](#).

Installing the Linerless Media Cutter

The standard bezel must be removed and DC input power disconnected before the Linerless Media Cutter Module can be installed. Go to [Removing the Standard Bezel on page 56](#).

1. Open the printer and remove and replace the standard platen roller with the Linerless platen roller. Go to [Platen Cleaning and Replacement on page 255](#) for a replacement procedure. Go to [Installing the Printhead Resolution Upgrade Kits on page 63](#) to help you identify platen rollers.
2. Place the Cutter module and printer right side up with the top of the module even with the bottom of the top cover.
3. Center and push the module into the front of the printer and slide it up until it stops.
4. Turn the printer upside down and attach the module to the printer with the two screws using the T10 wrench.

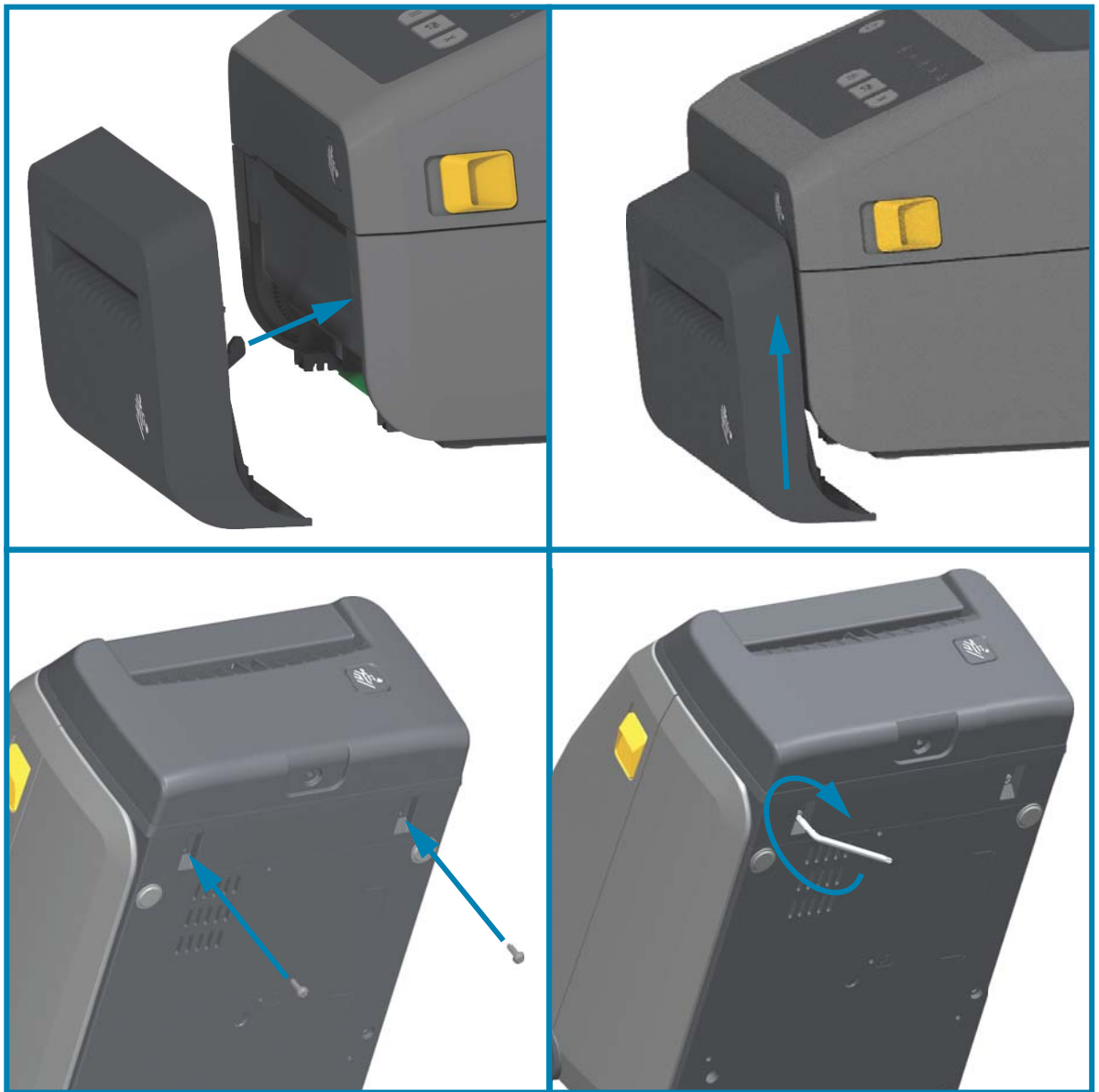

NOTE: For best printer performance, update the printer's firmware after installing options or immediately after the printer's initial setup. Go to [Updating Printer Firmware on page 273](#).

Installing the Linerless Media ‘Tear-Off’ Bezel

The standard bezel must be removed and DC input power disconnected before the Linerless Tear-Off Bezel module can be installed. Go to [Removing the Standard Bezel on page 56](#).

1. Open the printer and remove replace the standard platen roller with the Linerless platen roller. Go to [Platen Cleaning and Replacement on page 255](#) for a replacement procedure. Go to [Installing the Printhead Resolution Upgrade Kits on page 63](#) to help you identify platen rollers.
2. Place the Tear-Off bezel module and printer right side up with the top of the module even with the bottom of the top cover. Center and push the module into the front of the printer and slide it up until it stops.
3. Turn the printer upside down and attach the module to the printer with the two screws using the T10 wrench.

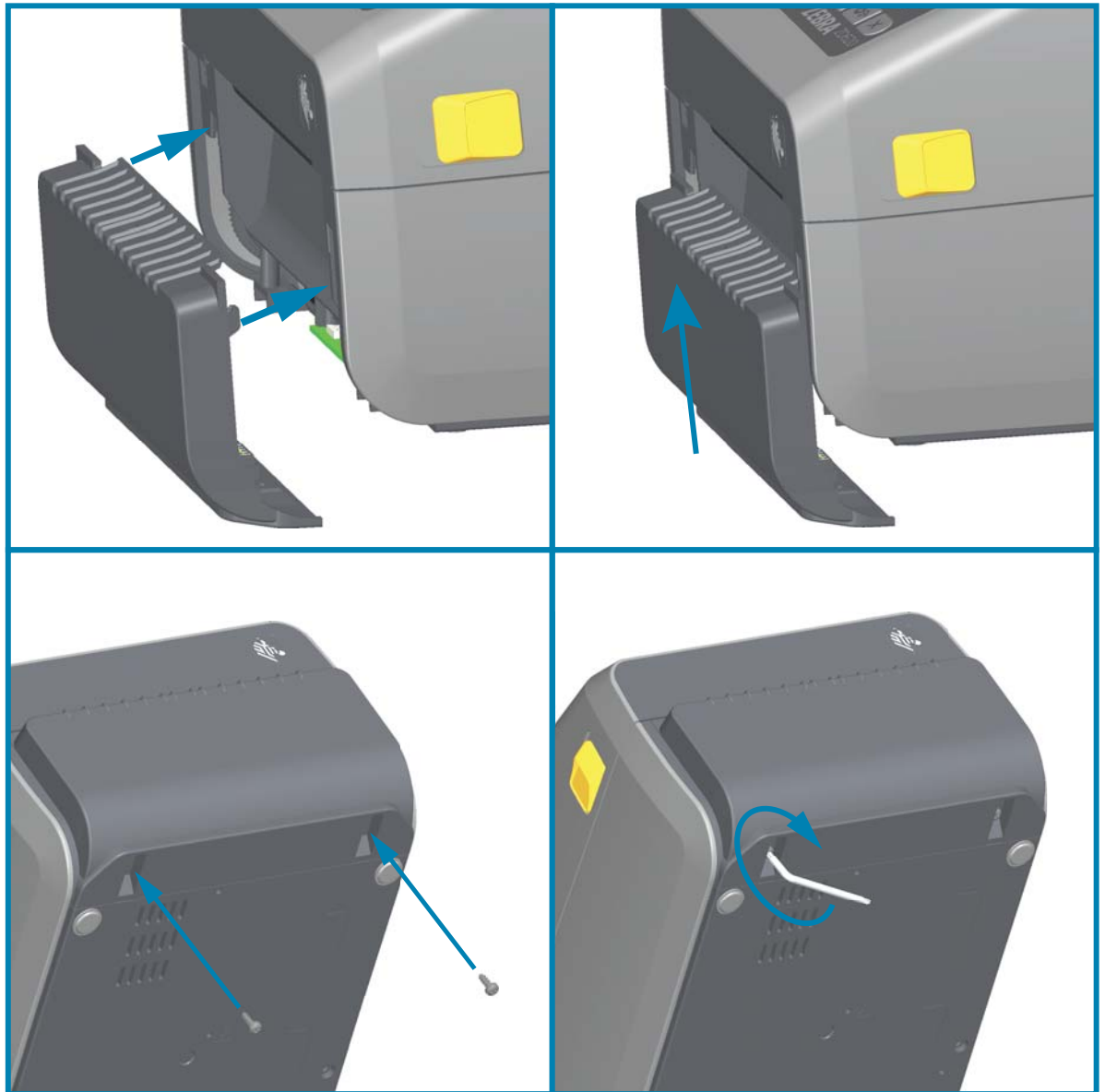

NOTE: For best printer performance, update the printer's firmware after installing options or immediately after the printer's initial setup. Go to [Updating Printer Firmware on page 273](#).

Media Roll Core Size Adapters

Adapter Kits

The media roll adapters kit includes three pairs of media roll adapters. The kits are for the following inner diameter (I.D.) media cores:

- 38.1 mm (1.5 in.)
- 50.8 mm (2.0 in.)
- 76.2 mm (3.0 in.)

Adapter Usage

- The adapters are intended to be permanently installed in the printer.
- They may be changed to support other media roll sizes that require one of these adapter sizes.
- The adapters may wear out if they are changed too much.
- Removing the media adapters to print on standard roll cores may leave plastic pieces in the media roll holders side areas that rub against the roll. Push those attached pieces back into the side of the media roll holder.

Installing Media Roll Adapters

1. Place one screw in the top adapter mounting hole of both of the roll holders. Start turning the screws clockwise using the T10 wrench until the tip of the screw is just protruding through the inside of the roll holder. The screws are self-tapping.

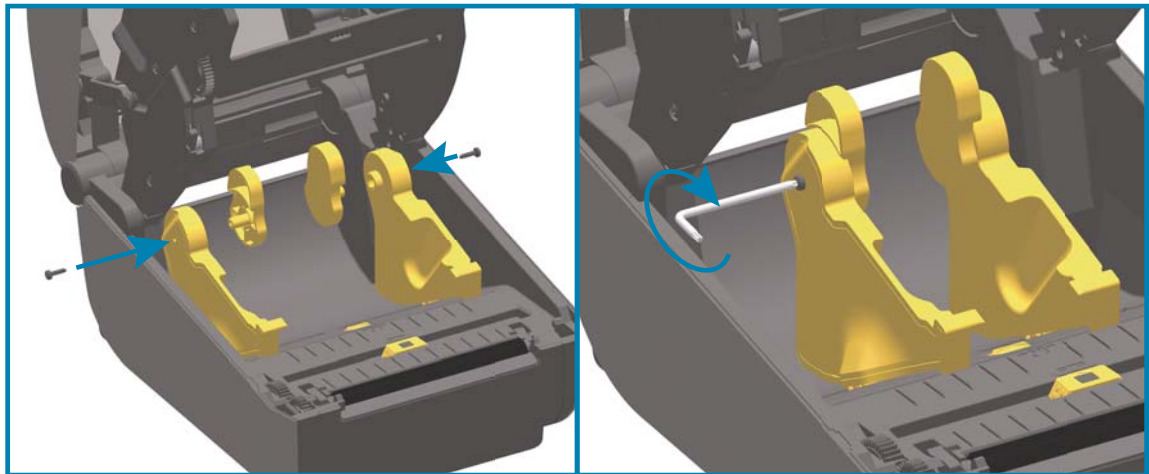

2. Place the adapter on the inside of the roll holder. The large side of the adapter is on top. The smooth side (no ribs) faces the middle of the printer.
3. Align the adapter's top screw hole to the protruding screw tip and pinch it tightly to the roll holder body. Tighten the screw until there is no gap between the adapter and roll holder. Do not tighten beyond this point. Over tightening will strip the thread.
4. Insert a screw in the bottom adapter mounting hole. Pinch the adapter tightly to the roll holder while tightening the screw. Tighten the screw until there is no gap between the adapter and roll holder. Do not tighten beyond this point. Over tightening will strip the thread.
5. Repeat step 1-4 for the other adapter and roll holder.

Example of Label Roll
with 76.2 mm (3.0 in.)
Inner Core
mounted on Media Core
Adapters

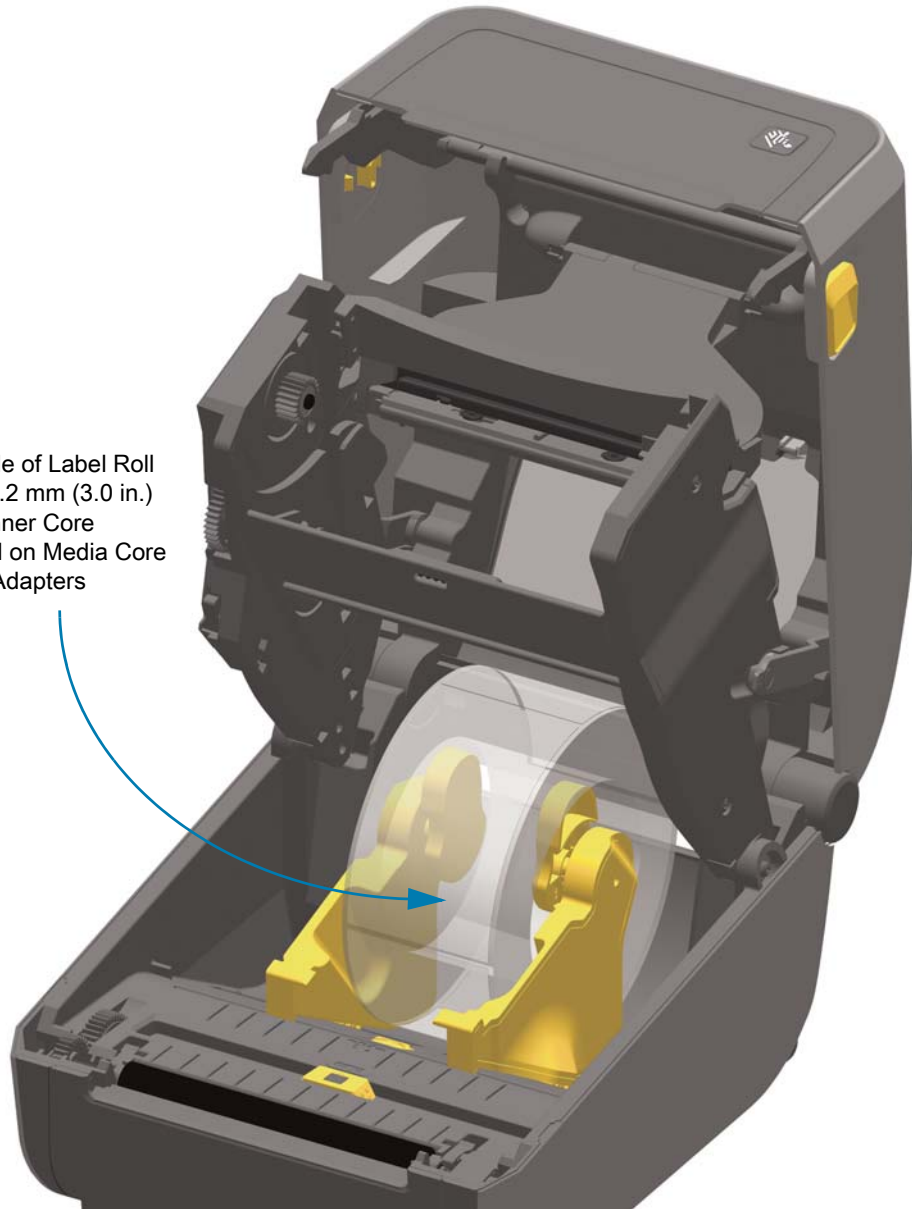

Print Resolution Upgrade Kits

There are four (4) print resolution upgrade kits. The same procedure is used to change all the printhead resolution upgrade kits. Both the printhead and platen (drive) rollers must be changed and are resolution dependent. The printer automatically detects the change in printheads and the platen roller materials are identified by color.

Standard Printing

- Change the printer from 203 dpi to 300 dpi printing.
- Change the printer from 300 dpi to 203 dpi printing.

Linerless Printing (for Direct Thermal ZD621 printers only)

- Change the printer from 203 dpi to 300 dpi printing.
- Change the printer from 300 dpi to 203 dpi printing.

Printheads used in the upgrade kits include a 203 or 300 marking to help you keep the unpackaged upgrade printhead separate from the original printhead. The original printhead contains no marking identifying its print resolution.

The platen (drive) rollers are colored differently to help you keep from accidentally using the old platen roller. Go to [Identifying Platen Drive Rollers Types on page 32](#).

Installing the Printhead Resolution Upgrade Kits

1. Turn the printer off and disconnect the power.
2. Use the platen roller replacement procedure. Go to [Platen Cleaning and Replacement on page 255](#).
3. Use the printhead replacement procedure. Go to [Replacing the Printhead on page 259](#).
4. Re-attach power and turn the printer on. The printer will automatically detect the change in printhead (but not the platen) when the printer verifies the printer's configuration.



IMPORTANT: For best results and the latest printer features and operation, download and install the latest printer firmware. Go to [Updating Printer Firmware on page 273](#).

Installing the Attached Power Supply Base Options

The power base is ready to attach to the printer. The base is installed using T10 wrench (that you supply) and the mounting screws provided with the upgrade kit. The direct thermal printer models attach to the printer with three screws and thermal transfer printer models use four screws.

1. Remove any media rolls from the printer. Remove the original power supply cable from the back of the printer.
2. Turn the printer over and align the power base to the bottom of the printer with the printer power plug oriented toward the rear of the printer. The printer's rubber feet align with recesses in the top of the power base.
3. Use the screws provided to attach the power base to the printer. Three screws for Direct Thermal printers. Four screws for Thermal Transfer printers. Tighten the screws using the T10 wrench supplied in the kit.

Thermal Transfer Printers

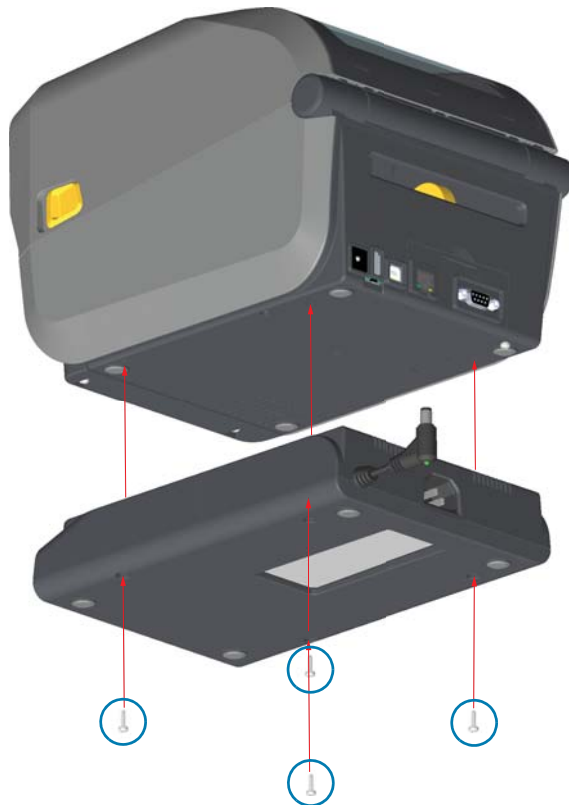

Direct Thermal Printers



4. Insert the DC input power plug into the printer.

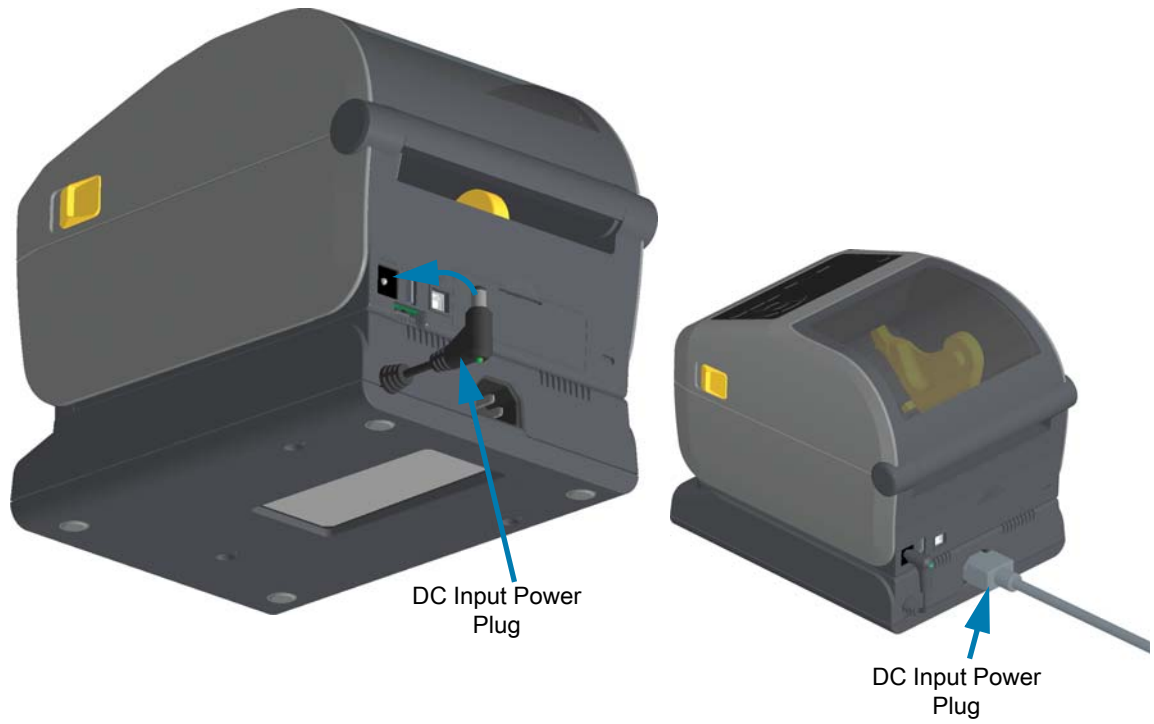

5. Re-connect the AC power cord to the printer power base.

Installing the Attached Battery Base Options

The battery base is ready to attach to the printer. The base is installed using a T10 wrench and the mounting screws provided with the upgrade kit. The direct thermal printer models attach to the printer with three (3) screws and thermal transfer printer models use four (4) screws.

1. Remove any media rolls from the printer. Remove the original power supply cable from the back of the printer.
2. Turn the printer over and align the power base to the bottom of the printer with the printer power plug oriented toward the rear of the printer. The printer's rubber feet align with recesses in the top of the power base.
3. Use the screws provided to attach the power base to the printer. Three (3) screws for Direct Thermal printers. Four (4) screws for Thermal Transfer printers. Tighten the screws using the T10 wrench supplied in the kit.

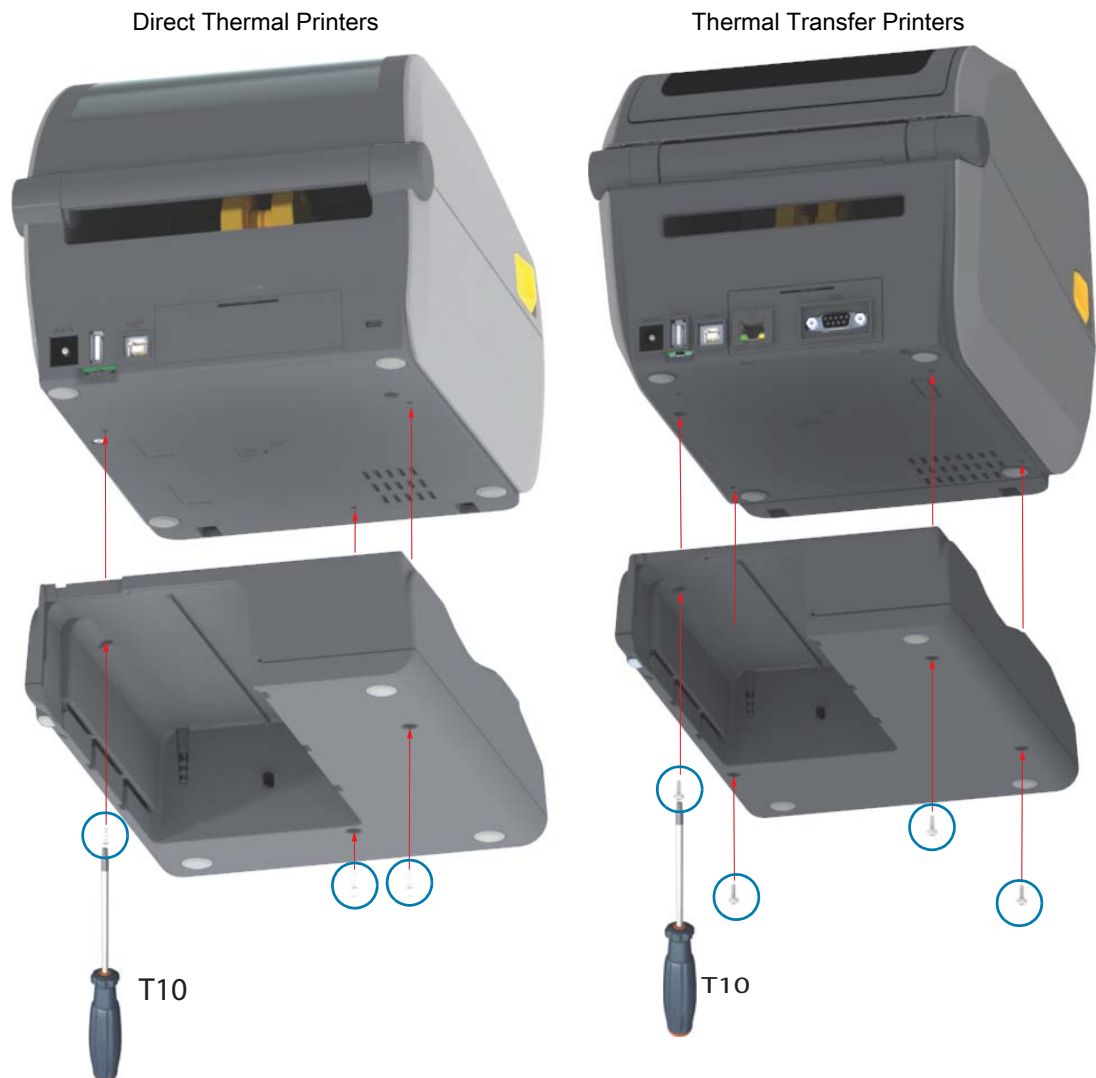

Installing the Battery into the Attached Power Base



IMPORTANT: The printer must have an Attached Battery Base installed and securely connected your printer to keep from damaging the printer or battery.

1. Disconnect the printer's external power supply from the DC Power Input located in the rear of the printer.
2. Slide the battery into the battery base's battery slot. Push the battery into the base until battery pack is flush to the rear of the battery base, and the connectors on the battery pack are engaged with the ports on the back of the printer.

Battery Ready to Install



Printer with Battery installed



Battery Latch



IMPORTANT: Batteries are shipped in Shutdown Mode for safety and to keep the battery from discharging during storage and shipping. The battery requires charging prior to initial use with the printer.

3. Attach the printer's power supply to the battery to wake up the battery from Shutdown Mode and begin its initial charge.



4. The printer must be fully charged before it's first use. Go to [Battery Indicators and Controls on page 45](#) to learn how to:
 - Turn the battery on.
 - Discover battery charge saving features and behaviors.
 - Check the battery's charge level and health.
5. The printer will take approximately two hours to reach a full charge. The battery status (health) indicator (lighting bolt) will go from Amber (Charging) to Green (Charged)

Color Touch Display and Controls

The printer's optional Color Touch Display provides easy access to your printer features, run print jobs, use wizards to assist you, and a visually interactive display to help you quickly through tasks and troubleshooting.

Color Touch Display Printer Controls

The Color Touch Display interface provides easy access to printer setup, configuration, and is customizable for all user types. The interface includes all the Standard User Interface controls and indicators to provide you with common functionality and behaviors for these Link-OS printer models.

button

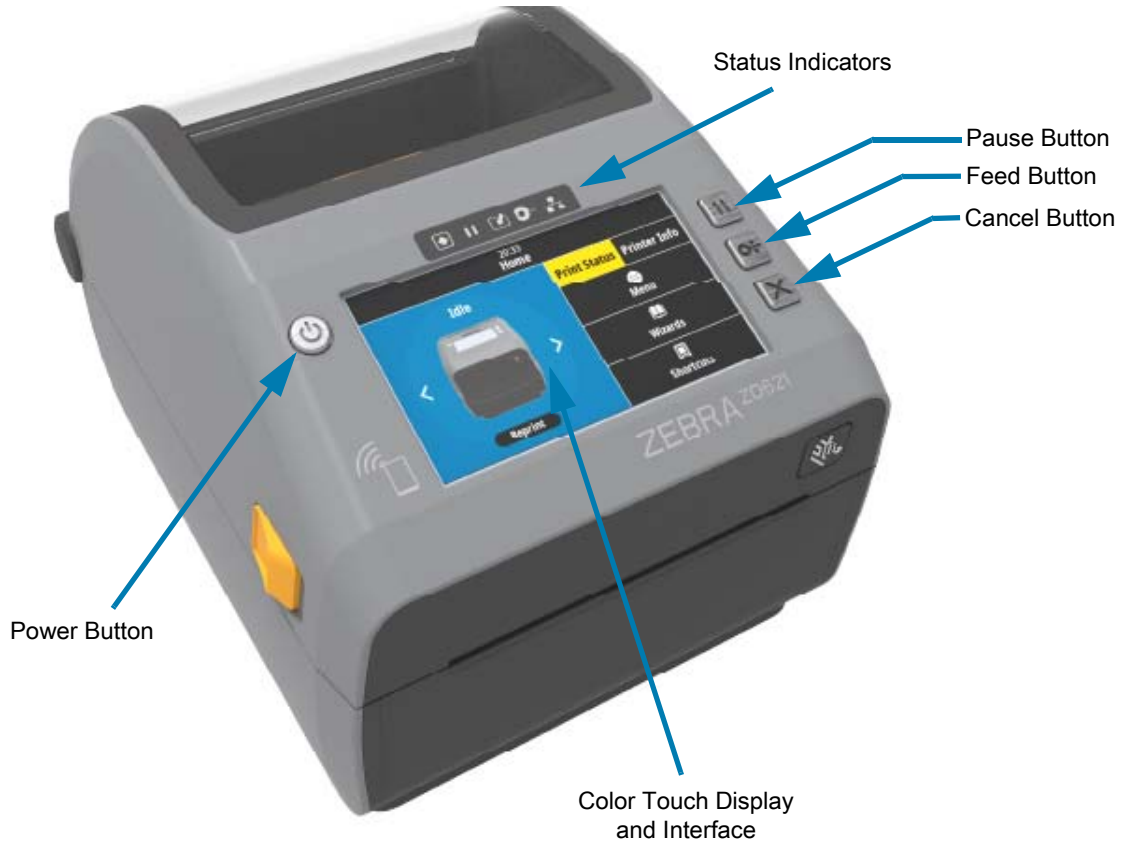

The printer's Standard Interface control; Power, Pause, Feed, and Cancel Buttons with the five printer Status Indicators are discussed in detail in [Controls and Indicators on page 37](#).

Home Screen

The printer's Home screen shows you the printer's current status and allows you to access the printer's menus. You can rotate the image of the printer 360 degrees to view it from all angles.

Printer Status

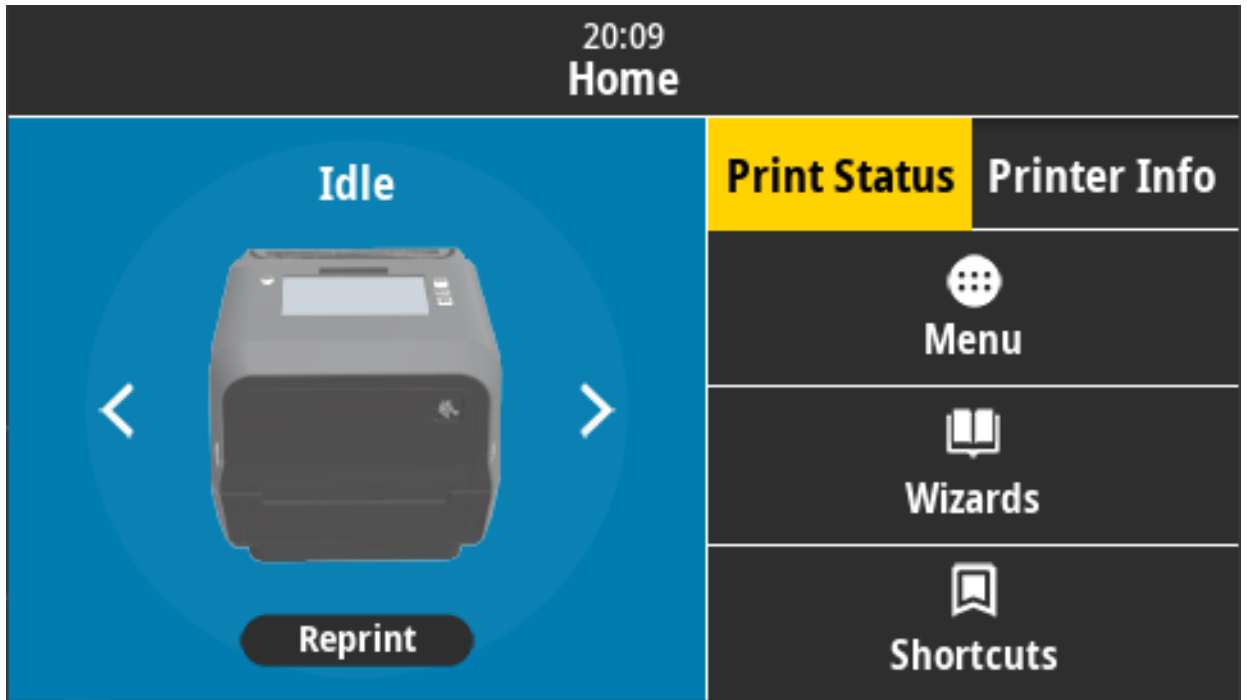

Printer Info

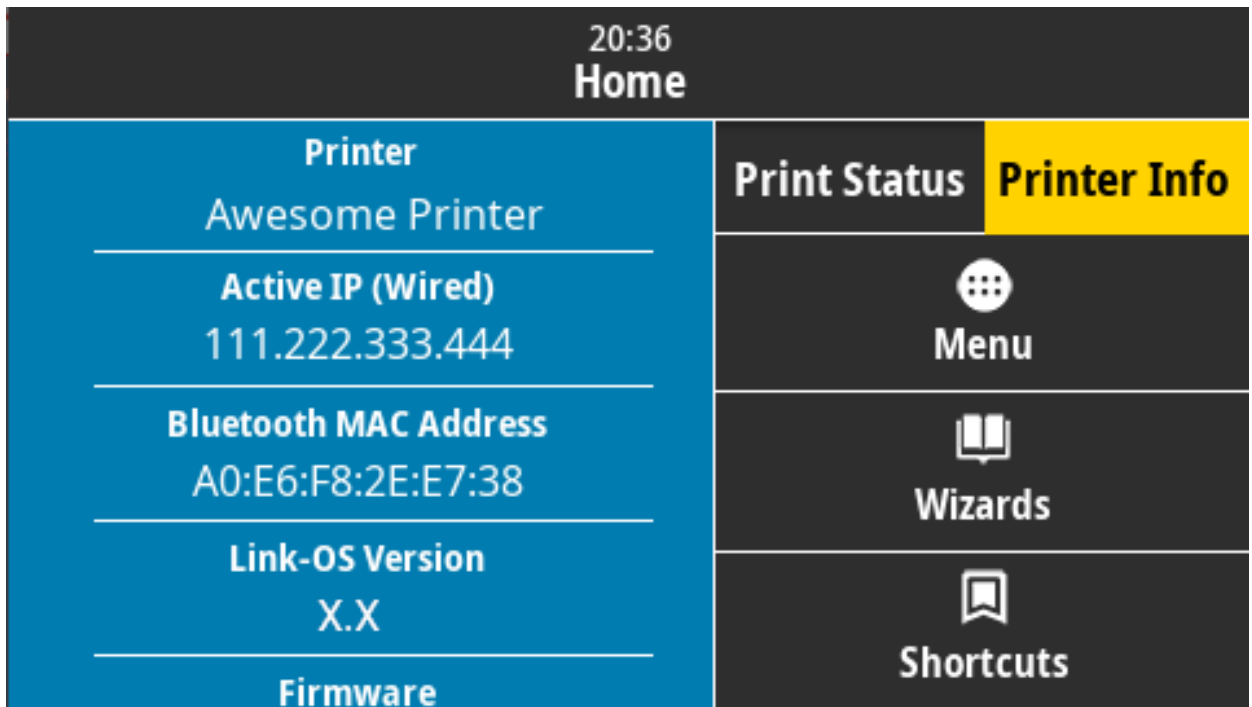

Printers with the optional Color Touch Display interface include the following features:

- The printer's **Standard Interface** controls and status indicators provide quick and easy access to common printed operations.
- The interactive **Color Touch Display** shows the normal operation status of the Home Screen with access to:
 - **Print Status** and **Printer Info** (information)
 - **Menu** — Is used to set and control printing and communications
 - **Wizards** — Allows you to change printer settings by going through prompts. Go to [Printer Wizards on page 72](#).
 - **Shortcuts** — Allows you to quickly access the most recent menu items and to save your favorites. Touch the darkened heart icon next to a menu item to save it to your list of favorites. Items in the favorites are shown in the order in which they were saved.

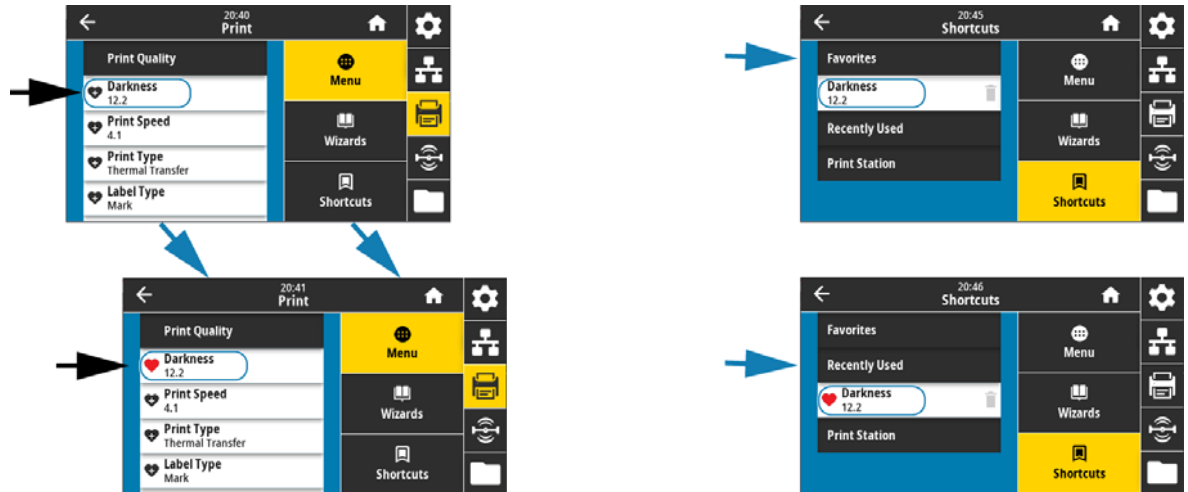

- The **Color Touch Display** shows the operator Alerts and Error messages:
 - If the background color of the Home Screen is yellow or red, the printer is in an alert or error state. For more information, go to [Resolving Alerts and Errors on page 274](#).
 - Displays a quick link to online instructions and "How to ..." videos for access by mobile devices.
 - Access to Onboard Help.

Printer Wizards

The printer Wizards can assist you by walking you through the setup process for various printer settings and features.



IMPORTANT: When using the Wizards, do not send data to the printer from the host. For best results, use full-width media running the Print or Set All Wizards. If the media is shorter than an image to be printed, the image may be truncated or print across multiple labels.

The following wizards are available:

- **Set All Wizard**—runs all the Wizards in sequence.
- **System Wizard**—sets up non-print related operating system settings.
- **Connection Wizard**—configures the printer's connectivity options.
- **Print Wizard**—configures key printing parameters and features.
- **RFID Wizard**—sets up the RFID subsystem's operations.

On the **Home** screen, touch **Wizards** to see the available options. For more information about individual settings set by any of the wizards, go to [User Menus on page 74](#).

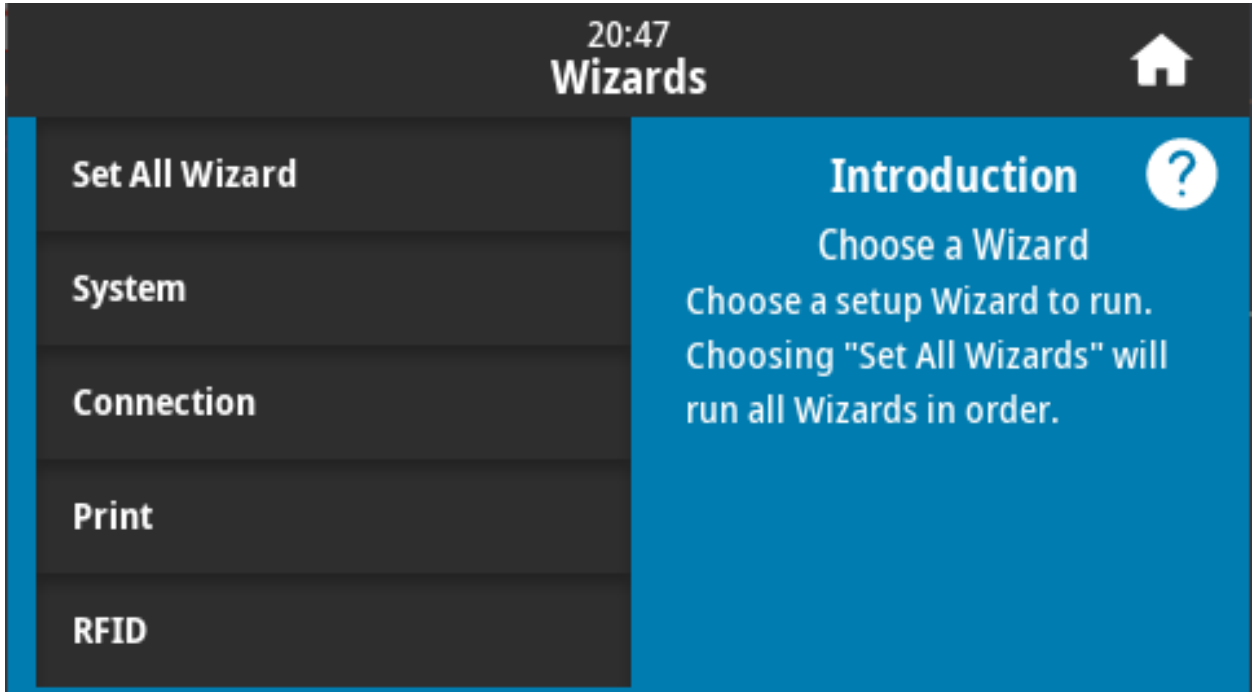

User Menus

The printer's user menus can be used to configure the printer.

See the following menu sections:

- [System Menu on page 75](#)
- [Connection Menu on page 89](#)
- [Print Menu on page 117](#)
- [RFID Menu on page 137](#)
- [Storage Menu on page 148](#)

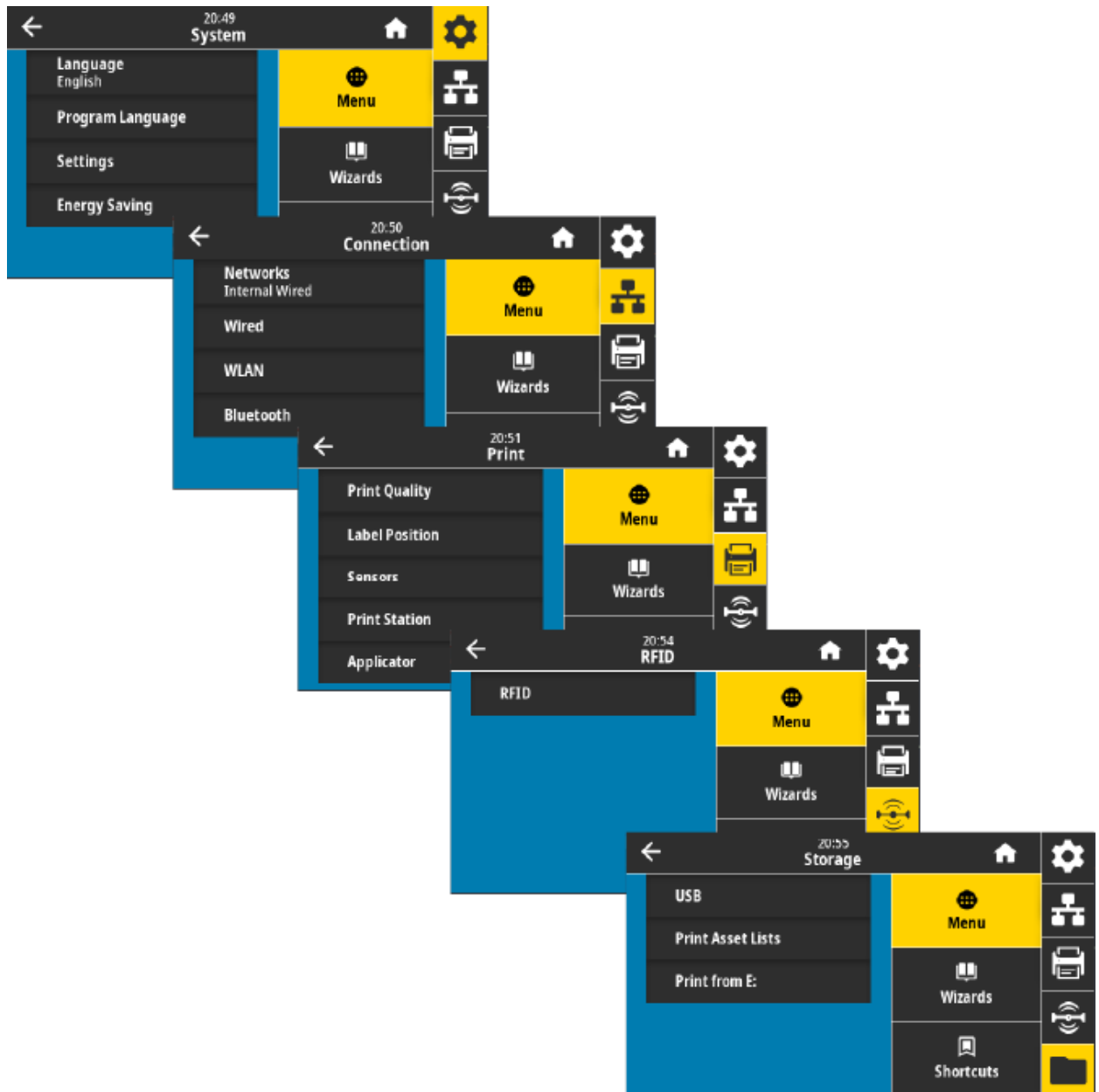

The user menu descriptions include other ways to change the same settings when other options exist. You can also use the printer's wizards to change some of the settings. Go to [Printer Wizards on page 72](#).

System Menu

Use System menu items to set printer function, operational options, languages, and restore defaults.

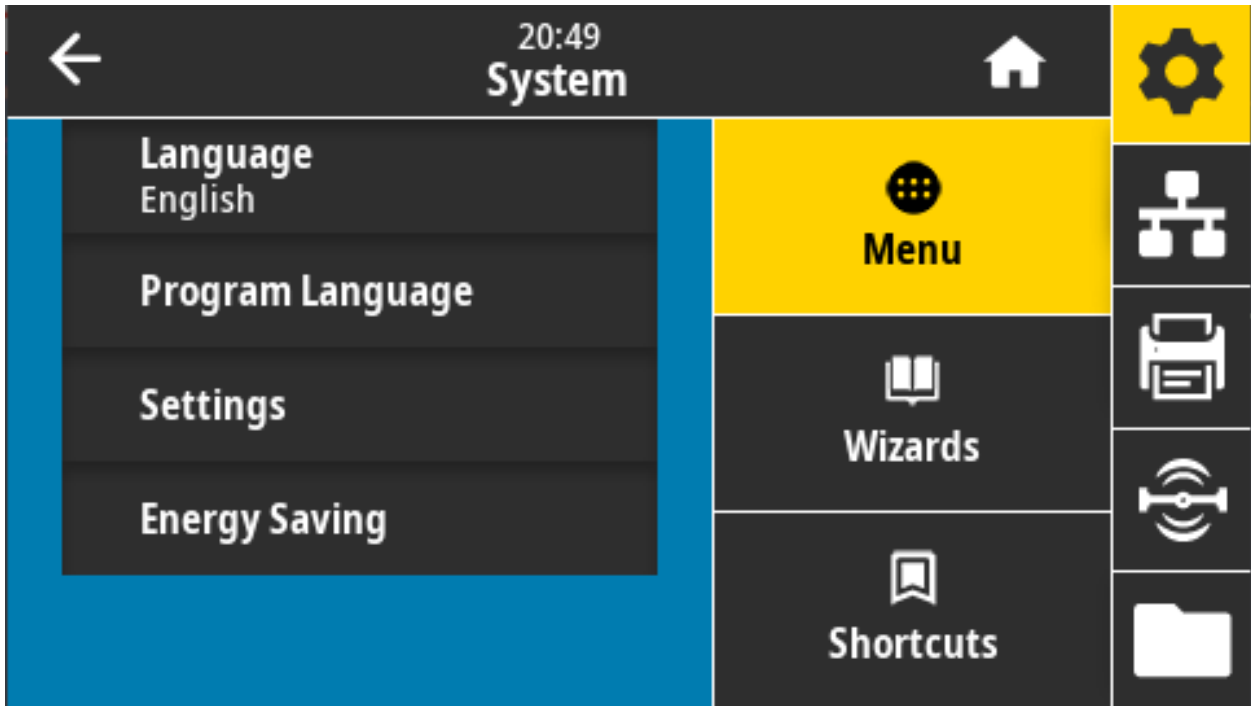

System > Language

Use this setting to select from 19 language choices for your printer's displayed and printed information.



NOTE: The language selections for this parameter are displayed by language name in the language of the displayed name.

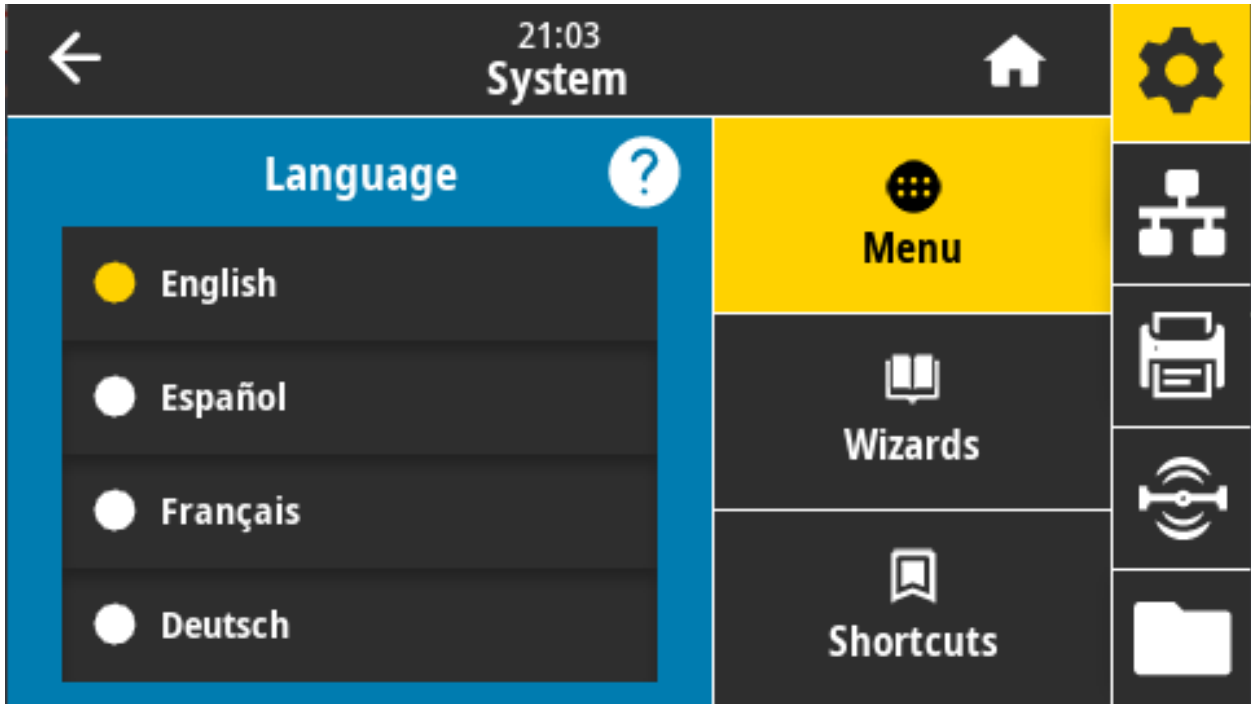

Accepted values: ENGLISH, SPANISH, FRENCH, GERMAN, ITALIAN, NORWEGIAN, PORTUGUESE, SWEDISH, DANISH, DUTCH, FINNISH, CZECH, JAPANESE, KOREAN, ROMANIAN, RUSSIAN, POLISH, SIMPLIFIED CHINESE, TRADITIONAL CHINESE

Related ZPL command(s): ^KL

SGD command used: print.tone

Print Server web page: View and Modify Printer Settings > General Setup > Language

System > Program Language > Diagnostic Mode

Use Communications Diagnostics Mode to enable the printer to output all communication as printed data for advanced troubleshooting.

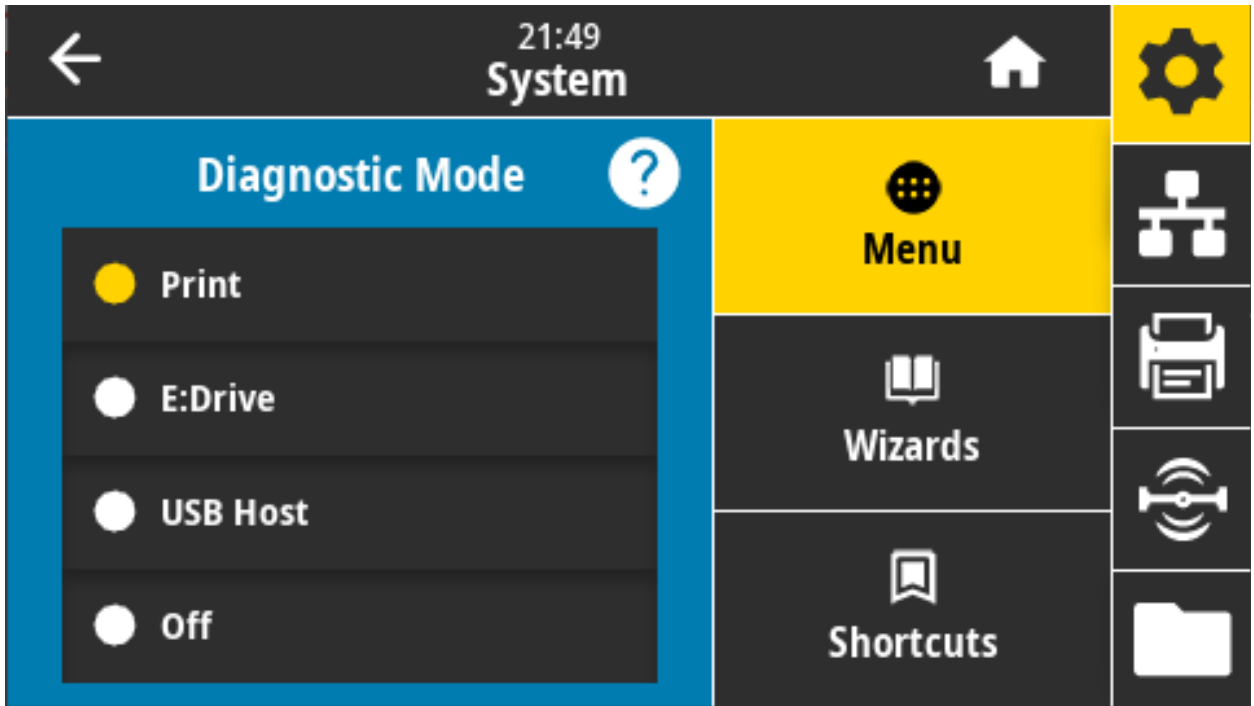

Accepted values: Print, E:Drive, USB Host, Off

Related ZPL command(s): For Print Diagnostics only: ~JD to enable, ~JE to disable

Print Server web page: View and Modify Printer Settings > General Setup > Language

Control panel key(s): For Print Diagnostics only: Hold PAUSE + FEED for 2 seconds when the printer is in the Ready state.

System > Program Language > Virtual Device

If any Virtual Device applications are installed on your printer, you may view or enable/disable them from this user menu.

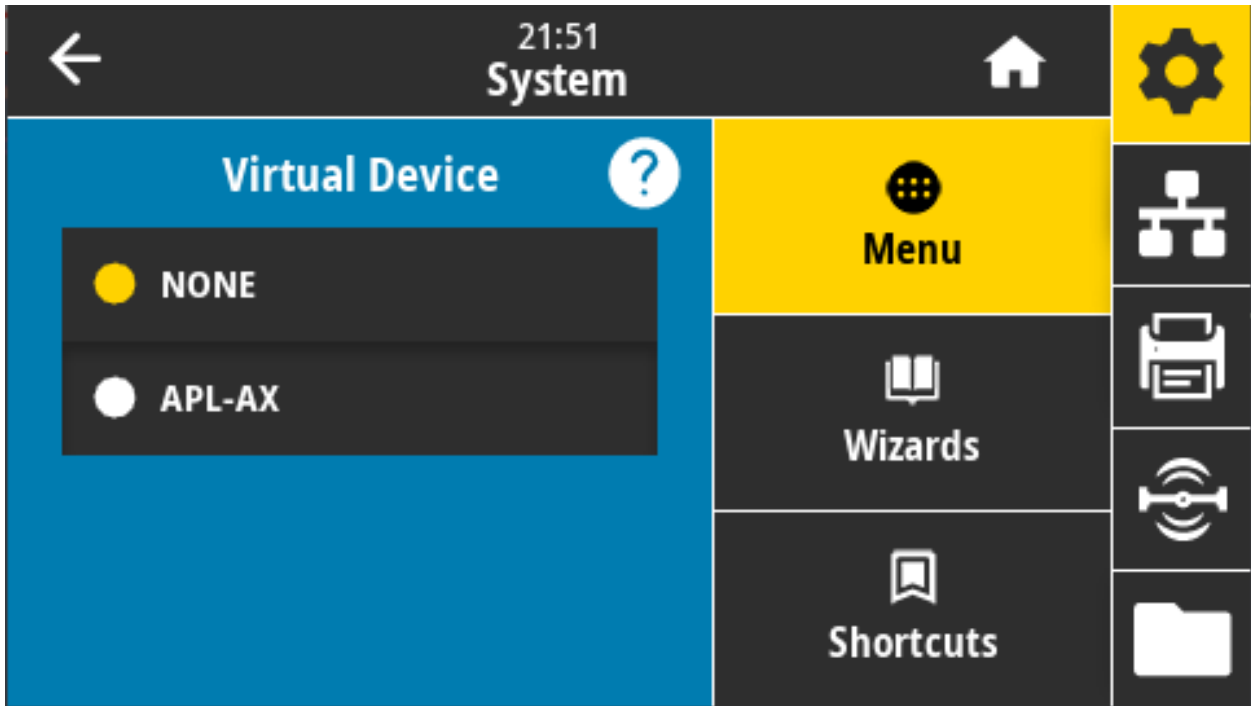

Accepted values: NONE or any Link-OS Virtual Device(s) will be in a list here.

System > Program Language > ZBI

Zebra Basic Interpreter (ZBI 2.0™) is a programming option that may be purchased for your printer.

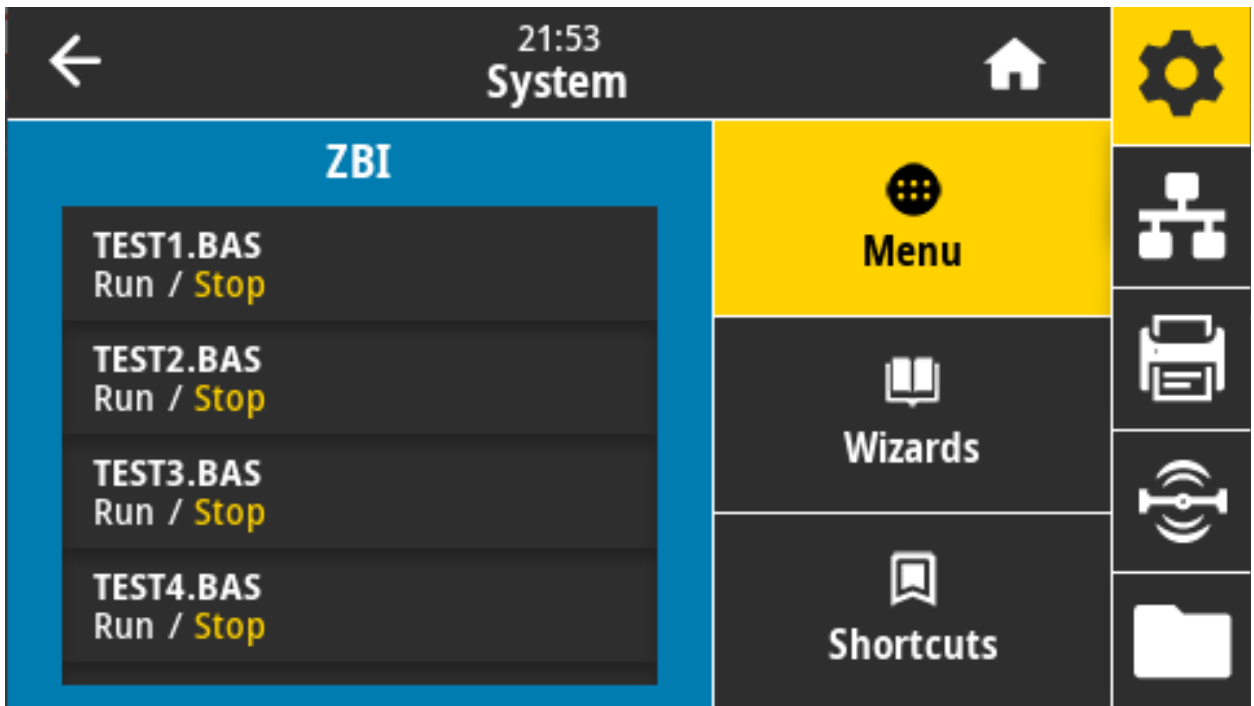

Zebra Basic Interpreter (ZBI 2.0™) is a programming option that may be purchased for your printer. If you would like to purchase this option, contact your Zebra reseller for more information.

If ZBI programs have been downloaded to your printer, you may select one to run using this menu item. If no program exists on your printer, NONE is listed.

When ZBI programs have been downloaded but none are running, the printer lists all available programs. To run one of them, touch Run (highlighted in white) under the program name.

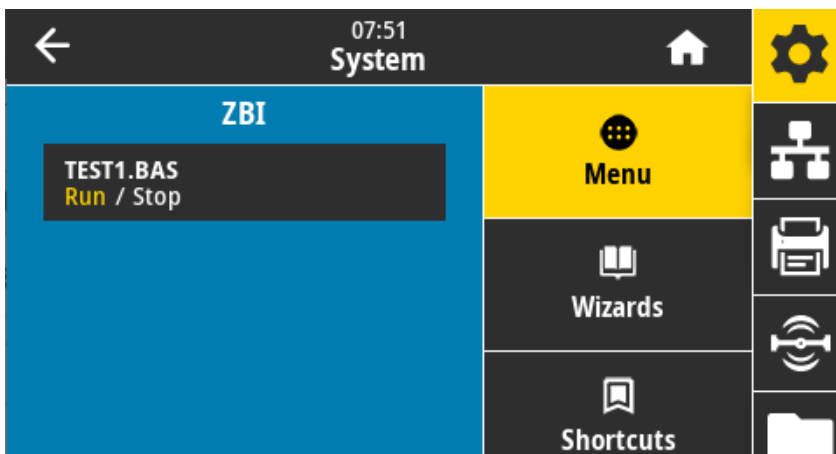

After a program is running, only that program is listed. Touch Stop (highlighted in white) to end the program.

SGD command used: `zbi.key` (identifies if the ZBI 2.0 option is enabled or disabled on the printer)

System > Settings > Display Time Format

Use this setting to select the time format used by the printer.

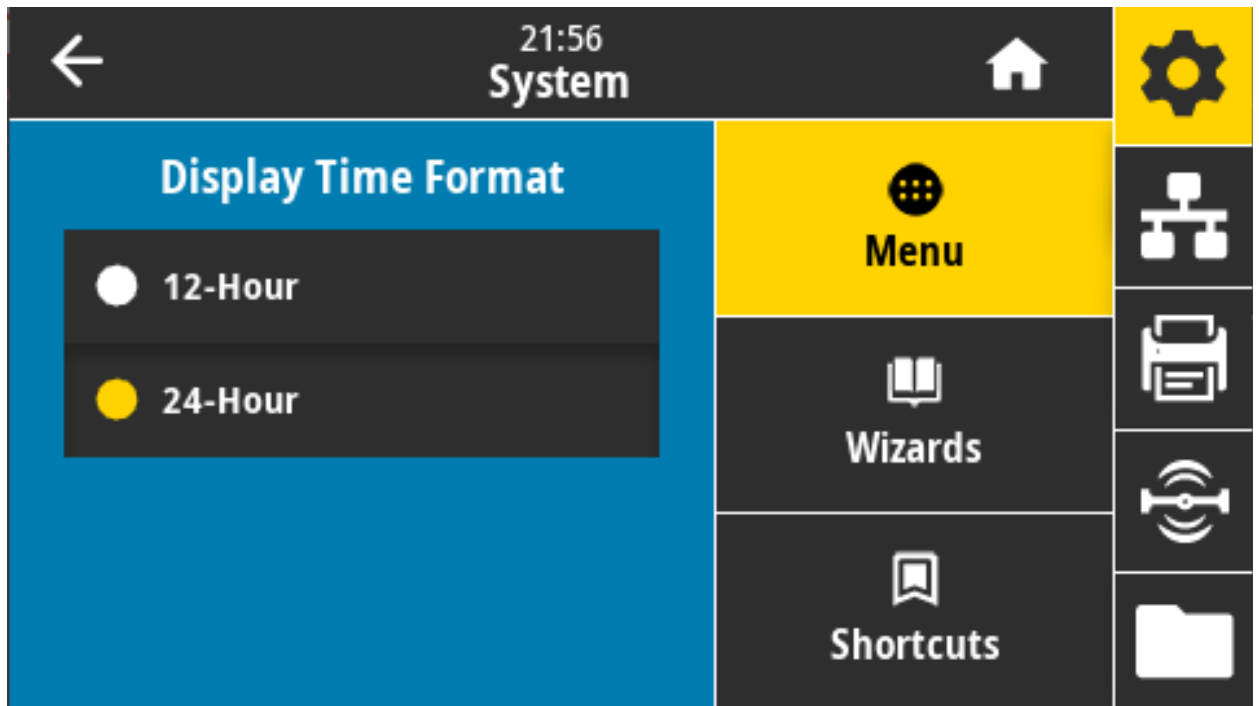

Accepted values: 12-Hour, 24-Hour

SGD command used: `device.idle_display_value`

System > Settings > Password Level

Use this setting to select the level of password protection for user menu items.

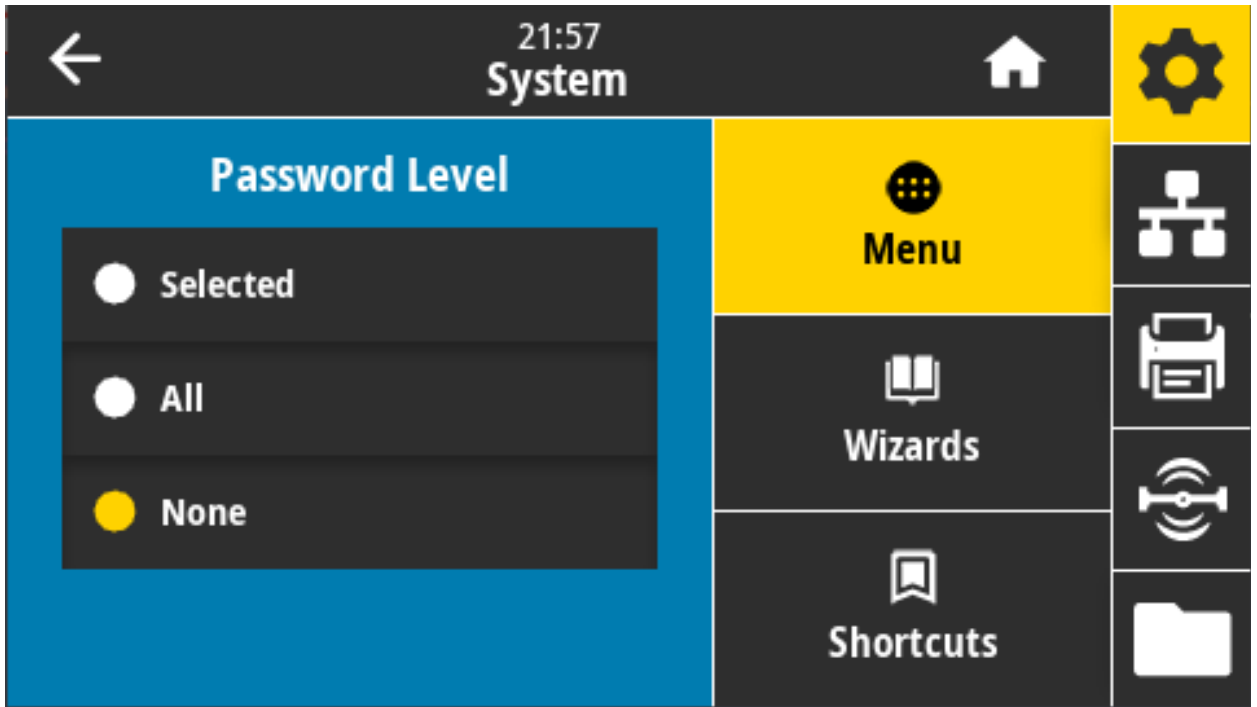

Accepted values: Selected, All, None

Related ZPL command(s): ^KP (to change the printer password)

System > Settings > Set Password

Set a new printer password for menu items protected by the previous parameter.

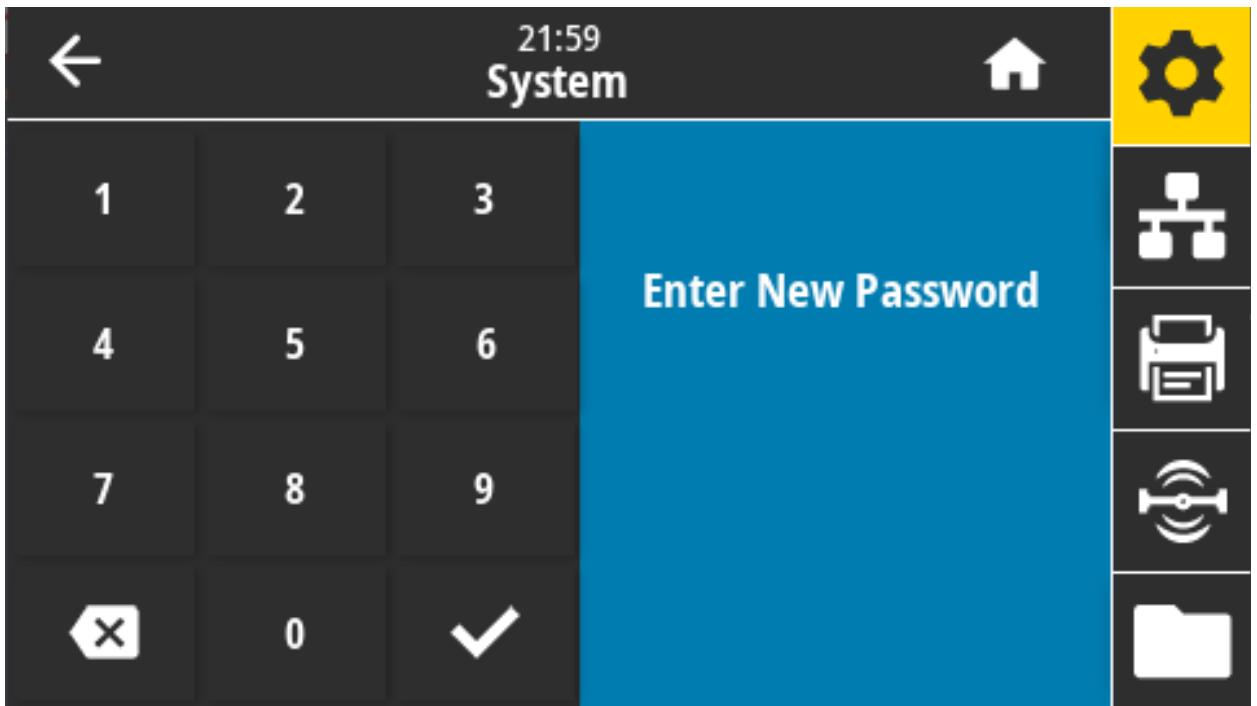

Accepted values: Numerals 0-9

The default printer password is 1234.

Related ZPL command(s): ^KP

System > Settings > Power Up Action

Set the action for the printer to take during the power-up sequence.

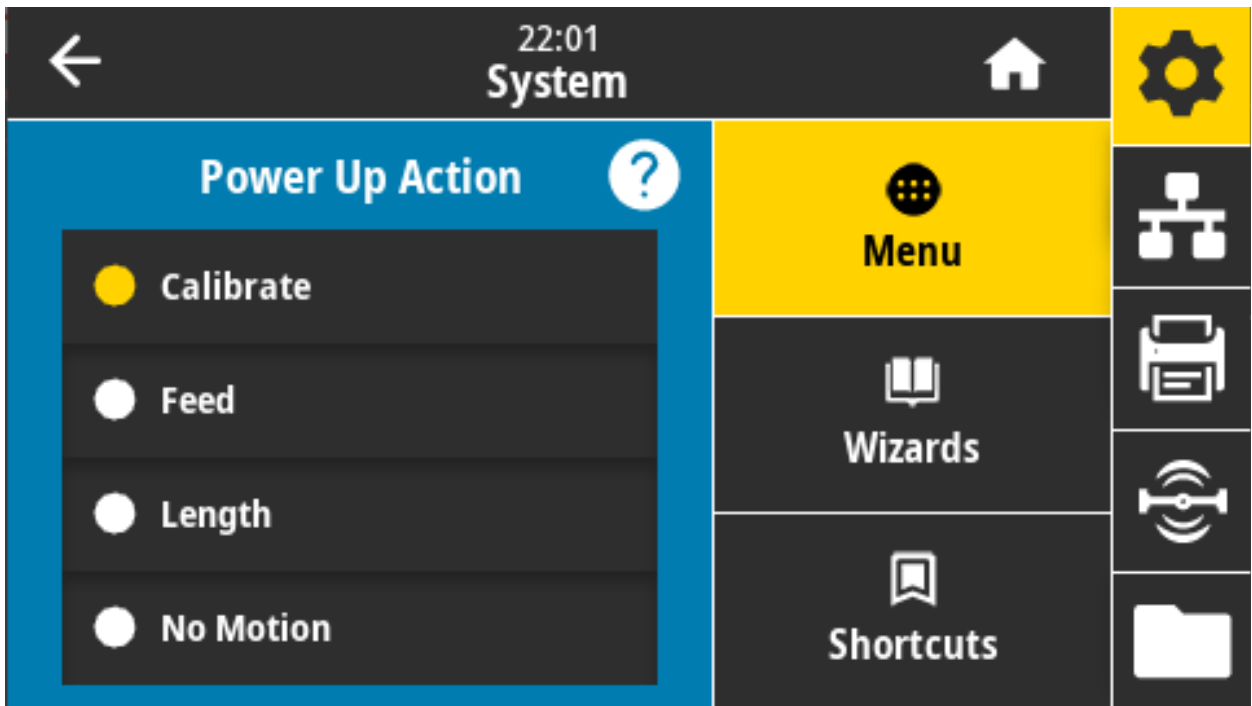

Accepted values:

CALIBRATE—Adjusts sensor levels and thresholds, determines the label length, and feeds the media to the next web.

FEED—Feeds the labels to the first registration point.

LENGTH—Determines the label length using current sensor values, and feeds the media to the next web.

NO MOTION—Tells the printer not to move the media. You must manually ensure that the web is positioned correctly, or press feed to position the next web.

SHORT CAL—Sets the media and web thresholds without adjusting sensor gain, determines the label length, and feeds the media to the next web.

Related ZPL command(s): ^MF

SGD command used: `ezp1.power_up_action`

Printer web page: View and Modify Printer Settings > Calibration

System > Settings > Head Close Action

Set the action for the printer to take when you close the printhead.

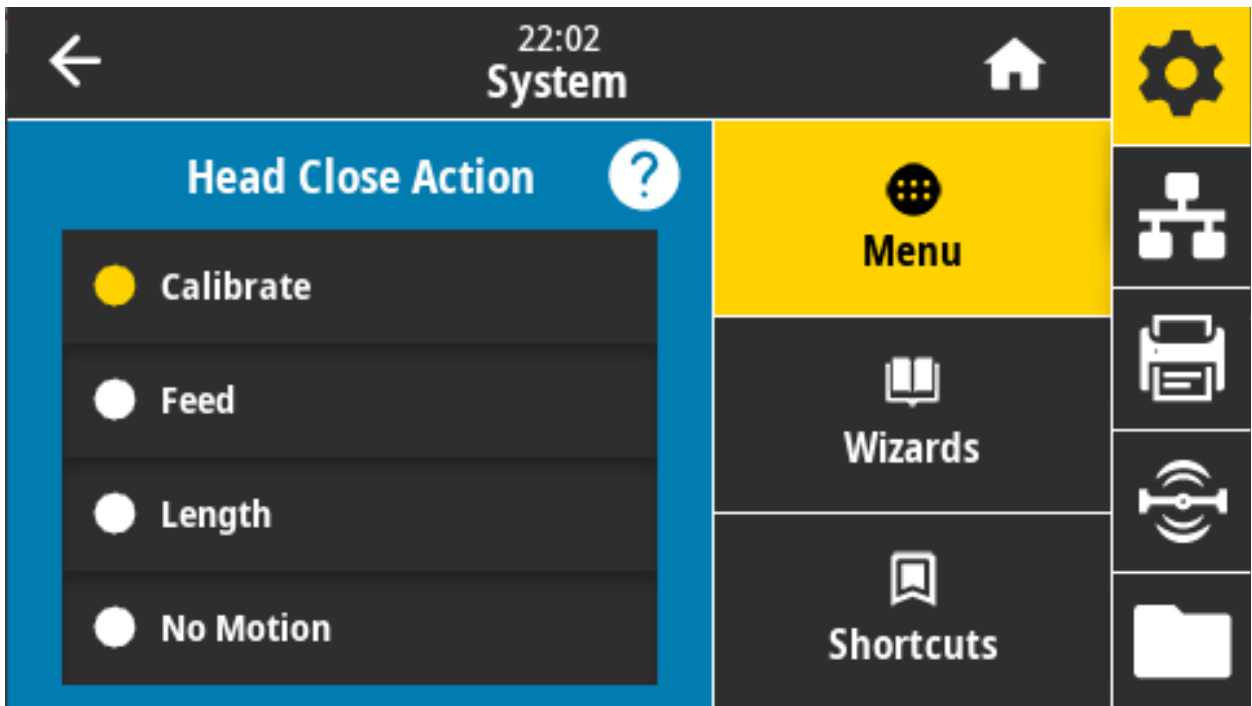

Accepted values:

CALIBRATE—Adjusts sensor levels and thresholds, determines the label length, and feeds the media to the next web.

FEED—Feeds the labels to the first registration point.

LENGTH—Determines the label length using current sensor values, and feeds the media to the next web.

NO MOTION—Tells the printer not to move the media. You must manually ensure that the web is positioned correctly, or press feed to position the next web.

SHORT CAL—Sets the media and web thresholds without adjusting sensor gain, determines the label length, and feeds the media to the next web.

Related ZPL command(s): ^MF

SGD command used: ezpl.head_close_action

Printer web page: View and Modify Printer Settings > Calibration

System > Settings > Screen Calibration

Touch each crosshair to calibrate the screen.



System > Settings > Restore Defaults

Restore specific printer, print server, and network settings back to the factory defaults.

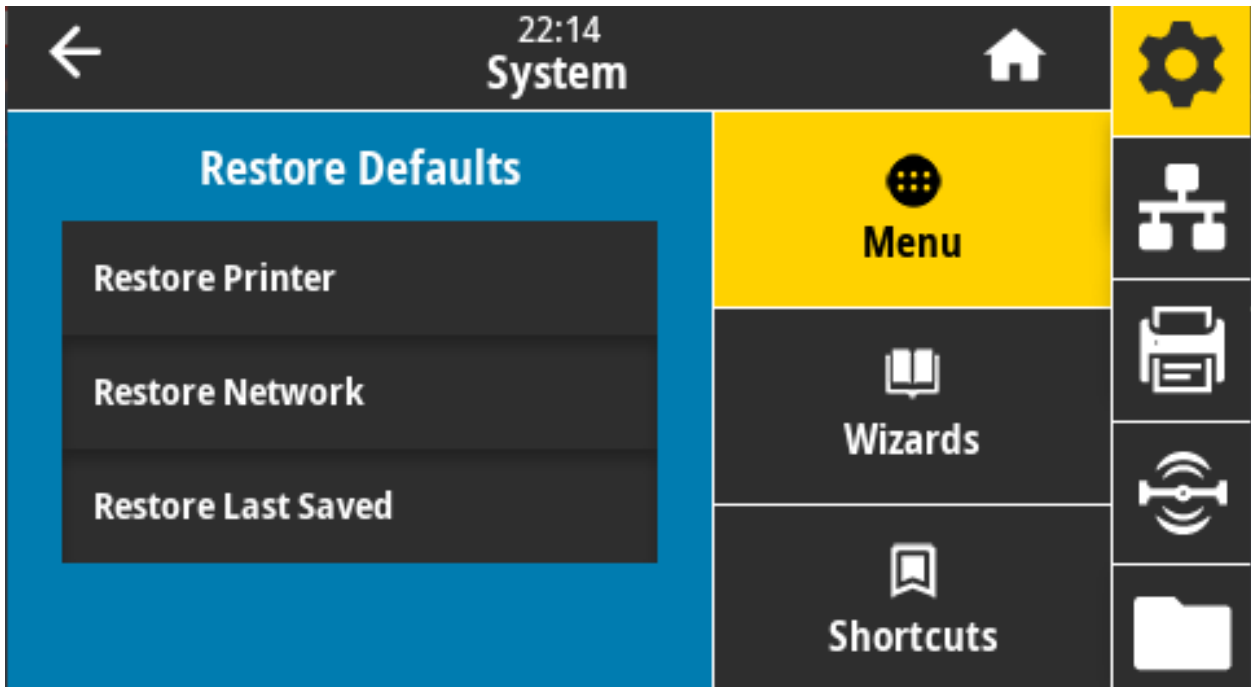

Use care when loading defaults because you will need to reload all settings that you changed manually. This menu item is available through two user menus with different default values for each.

Accepted values:

PRINTER—Restores all printer settings other than the network settings back to the factory defaults. Use care when loading defaults because you will need to reload all settings that you changed manually.

NETWORK—Reinitializes the printer's wired or wireless print server. With a wireless print server, the printer also re-associates with your wireless network.

LAST SAVED—Loads settings from the last permanent save.

NO MOTION—Tells the printer not to move the media. You must manually ensure that the web is positioned correctly, or press feed to position the next web.

SHORT CAL—Sets the media and web thresholds without adjusting sensor gain, determines the label length, and feeds the media to the next web.

Related ZPL command(s):

PRINTER— ^JUF

NETWORK— ^JUN

LAST SAVED— ^JUR

Control panel key(s): Hold **FEED** + **PAUSE** during printer power-up to reset the printer parameters to factory values.

Printer web page:

PRINTER—View and Modify Printer Settings > Restore Default Configuration

NETWORK—Print Server Settings > Reset Print Server

LAST SAVED—View and Modify Printer Settings > Restore Saved Configuration

System > Settings > Print: System Settings

Prints a printer configuration report.

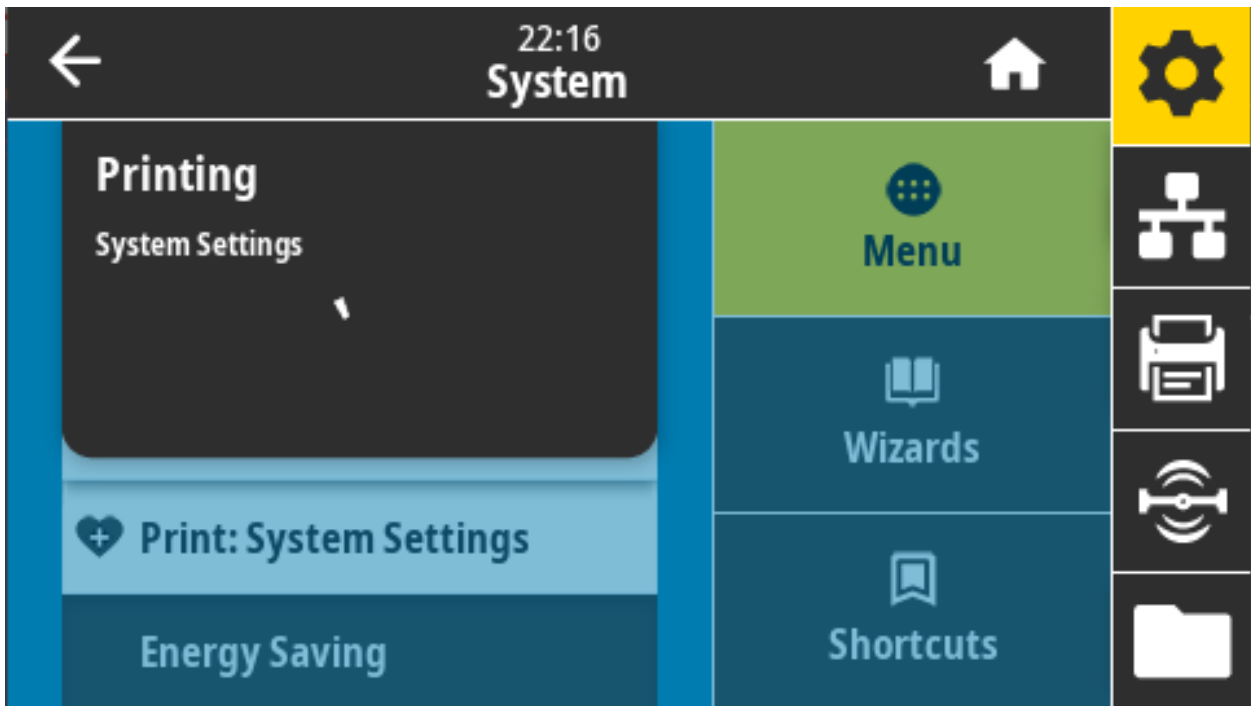

Related ZPL command(s): ~WC

Control panel key(s):

Hold **CANCEL** for 2 seconds during printer power-up.

Hold **FEED + CANCEL** for 2 seconds when the printer is in the Ready state.

Printer web page: View and Modify Printer Settings > Print Listings on Label

System > Energy Saving > Energy Star

When Energy Star mode is enabled, the printer goes into a “sleep” mode after a timeout period, thereby lowering power consumption. Press any button on the control panel to bring the printer back to an active state.

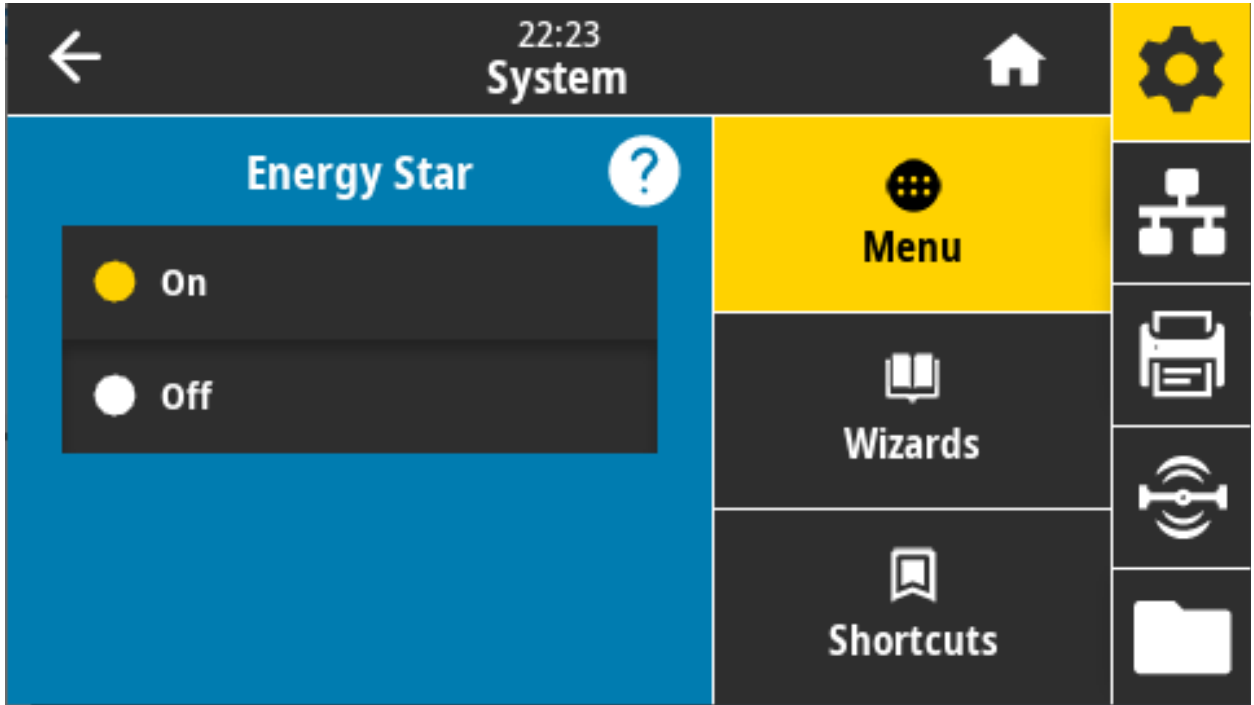

Accepted values: ON, OFF

SGD command used:

`power.energy_star.enable`

`power.energy_star.timeout`

Connection Menu

Use this menu to set connection parameters for wired and wireless (Wi-Fi and Bluetooth) printer communication.

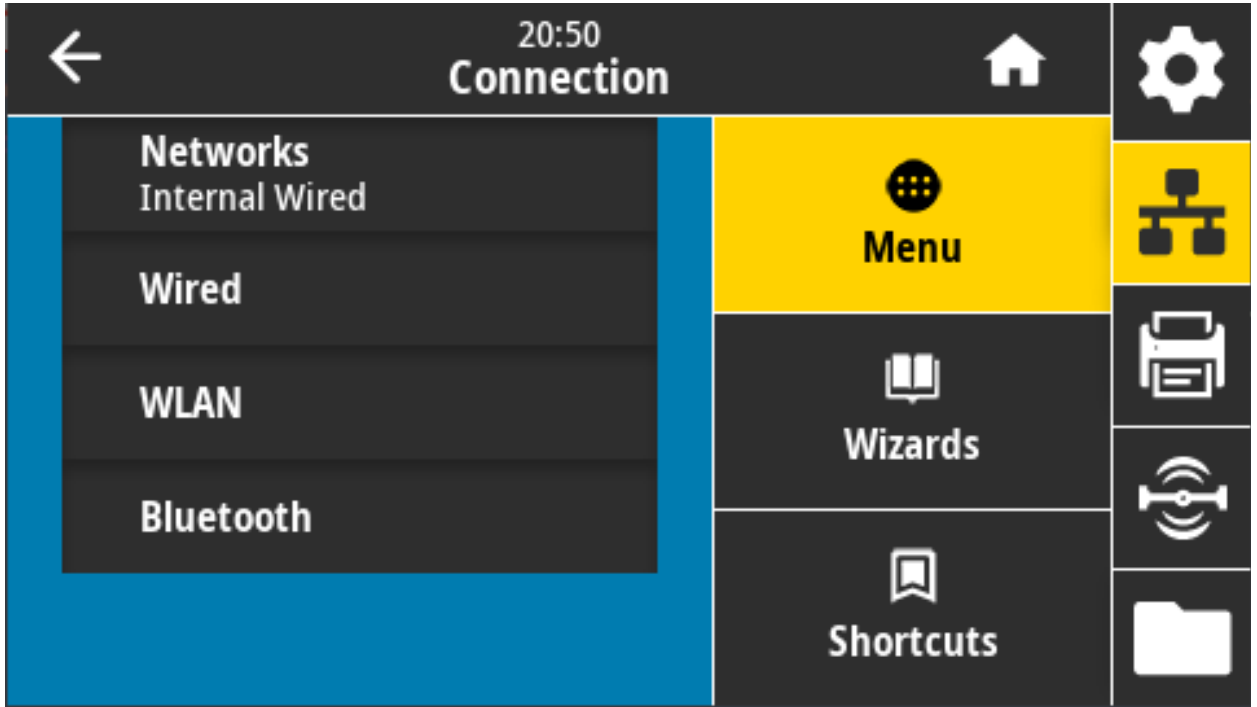

Connection > Networks > Reset Network

This option resets the wired or wireless print server and saves any changes that you made to any network settings.

You must reset the print server to allow changes to the network settings to take effect.

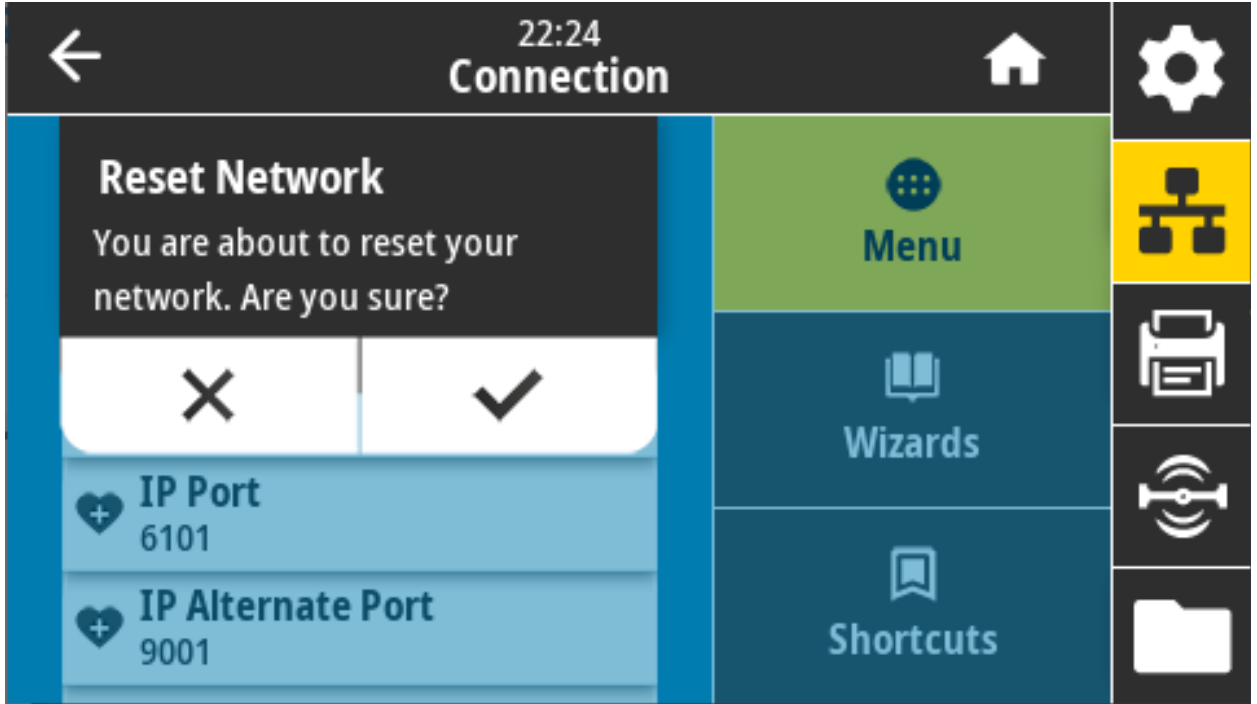

Related ZPL command(s): ~WR

SGD command used: device.reset

Printer web page: Print Server Settings > Reset Print Server

Connection > Networks > Primary Network

View or modify whether the wired or wireless print server is considered primary. You may select which one is primary.

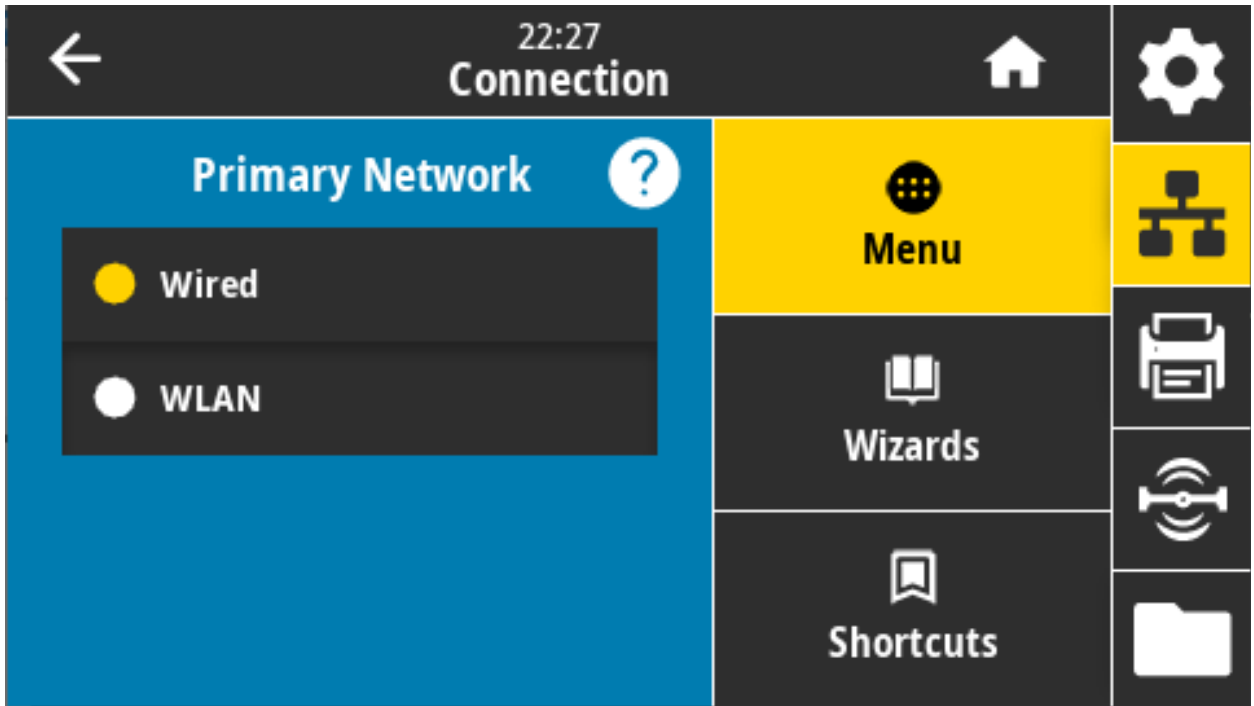

Accepted values: Wired, WLAN

Related ZPL command(s): ^NC

SGD command used: ip.primary_network

Connection > Networks > IP Port

This printer setting refers to the internal wired print server's port number that the TCP print service is listening on. Normal TCP communications from the host should be directed to this port.

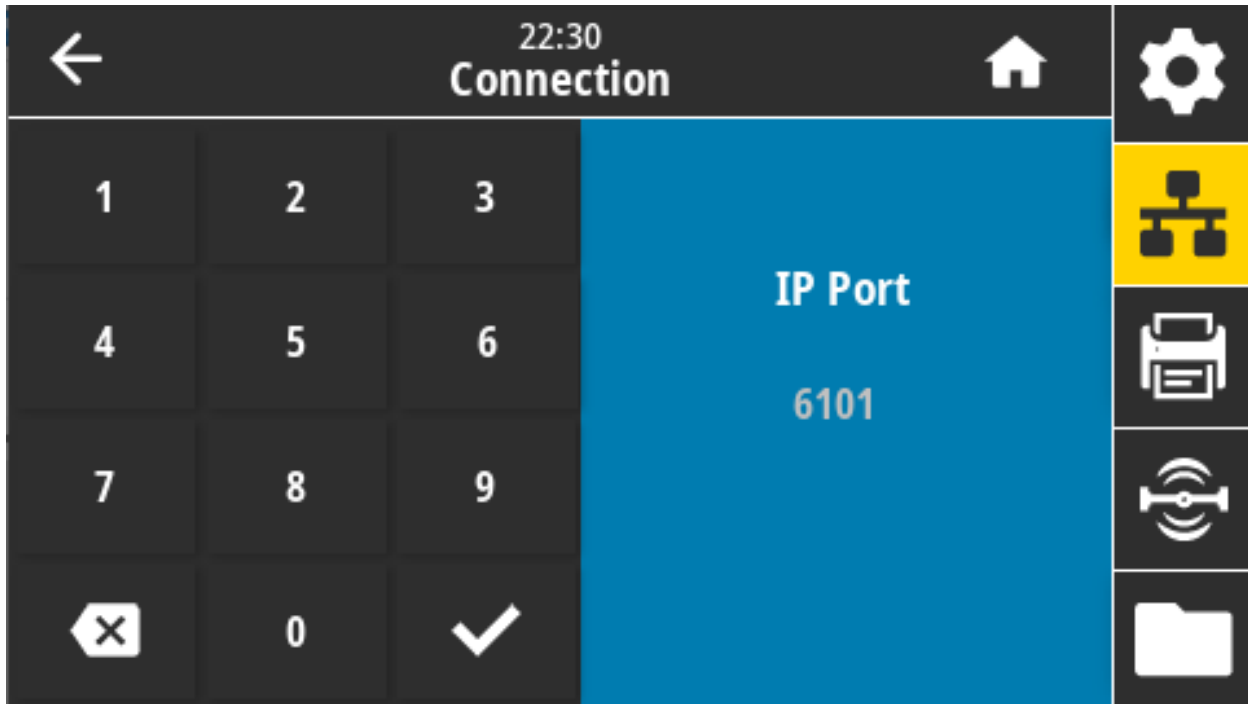

SGD command used: `internal_wired.ip.port`

Printer web page: View and Modify Printer Settings > Network Communications Setup > TCP/IP Settings

Connection > Networks > IP Alternate Port

This command sets the port number of the alternate TCP port.

Print servers supporting this command will monitor both the primary port and the alternate port for connections at the same time.

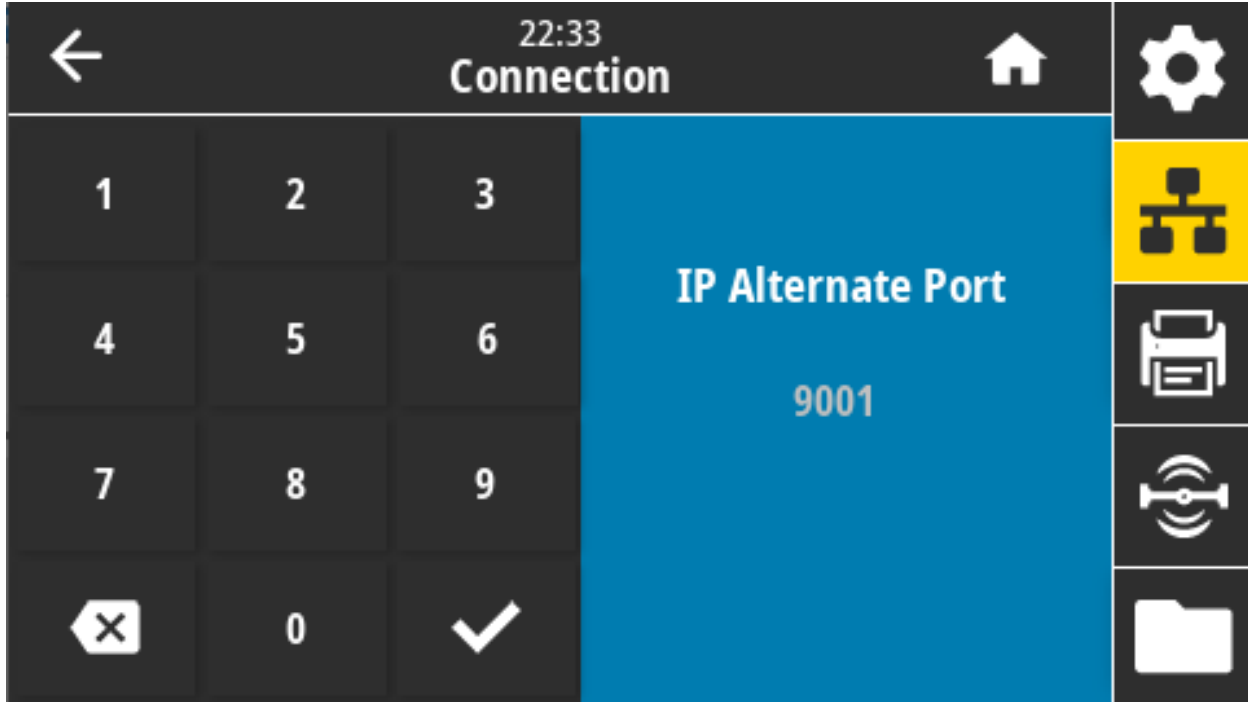

SGD command used:

```
internal_wired.ip.port_alternate
wlan.ip.port_alternate
```

Printer web page: View and Modify Printer Settings > Network Communications Setup > TCP/IP Settings

Connection > Networks > Print: Network Info

Prints the settings for any print server or Bluetooth device that is installed.

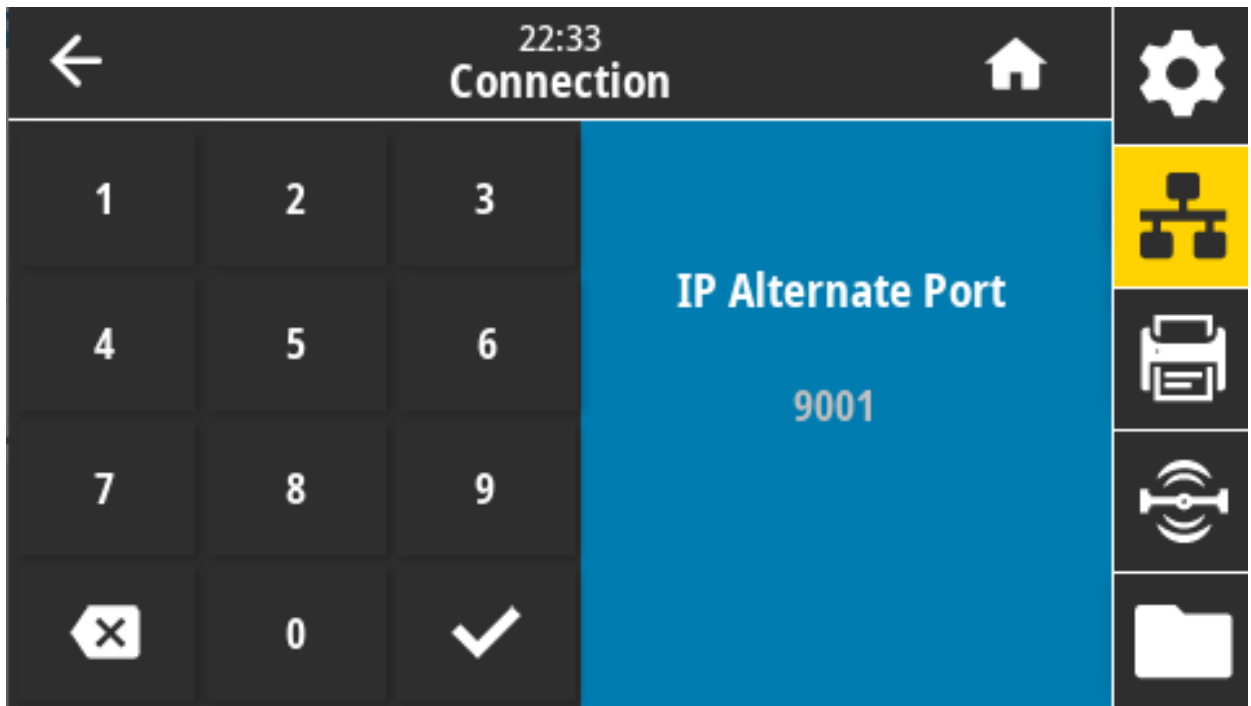

Related ZPL command(s): ~WL

Control panel key(s):

Hold **CANCEL** for 2 seconds during printer power-up.

Hold **FEED + CANCEL** for 2 seconds when the printer is in the Ready state.

Printer web page: View and Modify Printer Settings > Print Listings on Label

Network Configuration	
Zebra Technologies ZTC ZD600-203dpi ZPL XXXXXXXX-XXXX	
PrintServer.....	LOAD LAN FRONT
UNKNOWN.....	ACTIVE PRINTSRVR
Wired	
ALL.....	IP PROTOCOL
000.000.000.000.....	IP ADDRESS
255.255.255.000.....	SUBNET
000.000.000.000.....	GATEWAY
000.000.000.000.....	WINS SERVER IP
YES.....	TIMEOUT CHECKING
300.....	TIMEOUT VALUE
000.....	ARP INTERVAL
8100.....	BASE RAW PORT
8000.....	JSON CONFIG PORT
Wireless	
ALL.....	IP PROTOCOL
000.000.000.000.....	IP ADDRESS
255.255.255.000.....	SUBNET
000.000.000.000.....	GATEWAY
000.000.000.000.....	WINS SERVER IP
YES.....	TIMEOUT CHECKING
300.....	TIMEOUT VALUE
000.....	ARP INTERVAL
8100.....	BASE RAW PORT
8000.....	JSON CONFIG PORT
INSERTED.....	CARD INSERTED
024FH.....	CARD PFG ID
8118H.....	CARD PRODUCT ID
00100100100100100.....	MAC ADDRESS
YES.....	DRIVER INSTALLED
INFRASTRUCTURE.....	OPERATING MODE
123.....	SSID
100.....	TX POWER
ALL.....	CURRENT TX RATE
OPEN.....	WEP TYPE
NONE.....	WLAN SECURITY
1.....	WEP INDEX
000.....	WPA SIGNAL
LONG.....	PREPARE
NO.....	ASSOCIATED
ON.....	PULSE ENABLED
15.....	PULSE RATE
OFF.....	INTEL MODE
no1 available.....	REGION CODE
no region code.....	COUNTRY CODE
0x0FFFFFFF.....	CHANNEL MASK
Bluetooth	
4.2.0.....	FIRMWARE
04/20/2012.....	DATE
ON.....	DISCOVERABLE
3.0.....	RADIO VERSION
ON.....	ENABLED
AC:3F:84:05:1E71F9.....	MAC ADDRESS
XXXXXXXX-XX-XXXX.....	FRIENDLY NAME
No.....	CONNECTED
1.....	WLAN SECURITY MODE
NC.....	CONN SECURITY MODE
FIRMWARE IN THIS PRINTER IS COPYRIGHTED	

Connection > Networks > Visibility Agent

When the printer is connected to a wired or wireless network, it will attempt to connect to Zebra's Asset Visibility Service via the Cloud-based Zebra Printer Connector using an encrypted, certificate-authenticated web socket connection. The printer sends Discovery Data and Settings and Alerts Data. Data printed via any label formats is NOT transmitted. To opt-out of this feature, disable this setting.

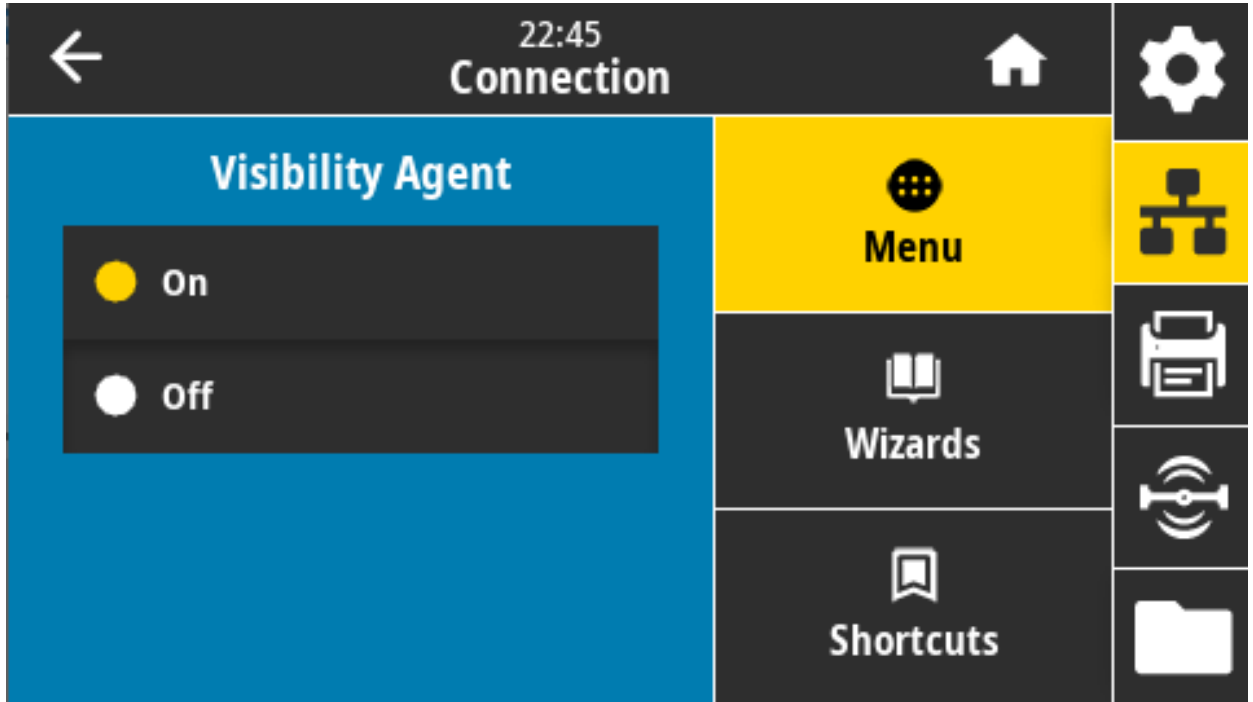

Accepted values: ON, OFF

SGD command used: `weblink.zebra_connector.enable`

Printer web page: View and Modify Printer Settings > Network Configuration > Cloud Connect Settings



NOTE: For more information, refer to the “Opting Out of the Asset Visibility Agent” application note at zebra.com.

Connection > Wired > Wired IP Protocol

This parameter indicates if the user (permanent) or the server (dynamic) selects the wired print server's IP address. When a dynamic option is chosen, this parameter tells the method(s) by which this print server receives the IP address from the server.

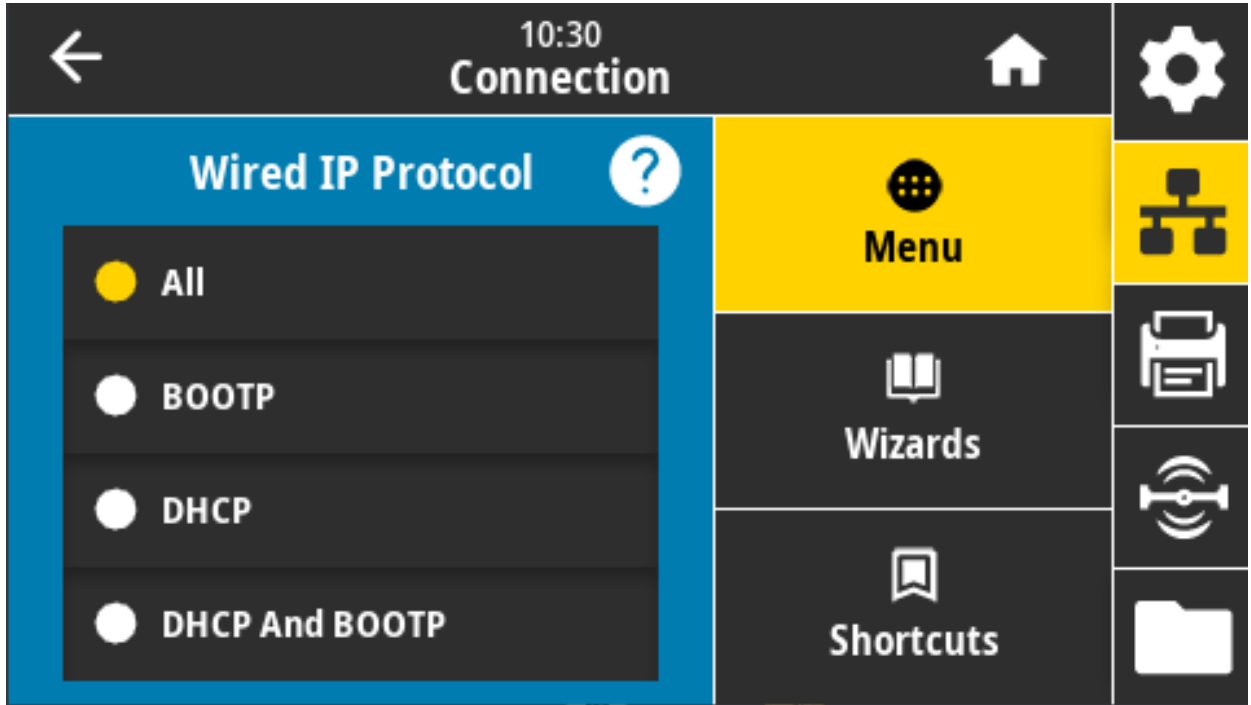

You must reset the print server to allow changes to the network settings to take effect. Go to [Connection > Networks > Reset Network on page 90](#)

Accepted values: ALL, GLEANING ONLY, RARP, BOOTP, DHCP, DHCP & BOOTP, PERMANENT

Related ZPL command(s): ^ND

SGD command used: internal_wired.ip.protocol1

Printer web page: View and Modify Printer Settings > Network Communications Setup > TCP/IP Settings

Connection > Wired > Wired IP Address

View and, if necessary, change the printer's wired IP address.

To save changes to this setting, set Connection > Wired > Wired IP Protocol to PERMANENT, and then reset the print server (go to [Connection > Networks > Reset Network on page 90](#)).

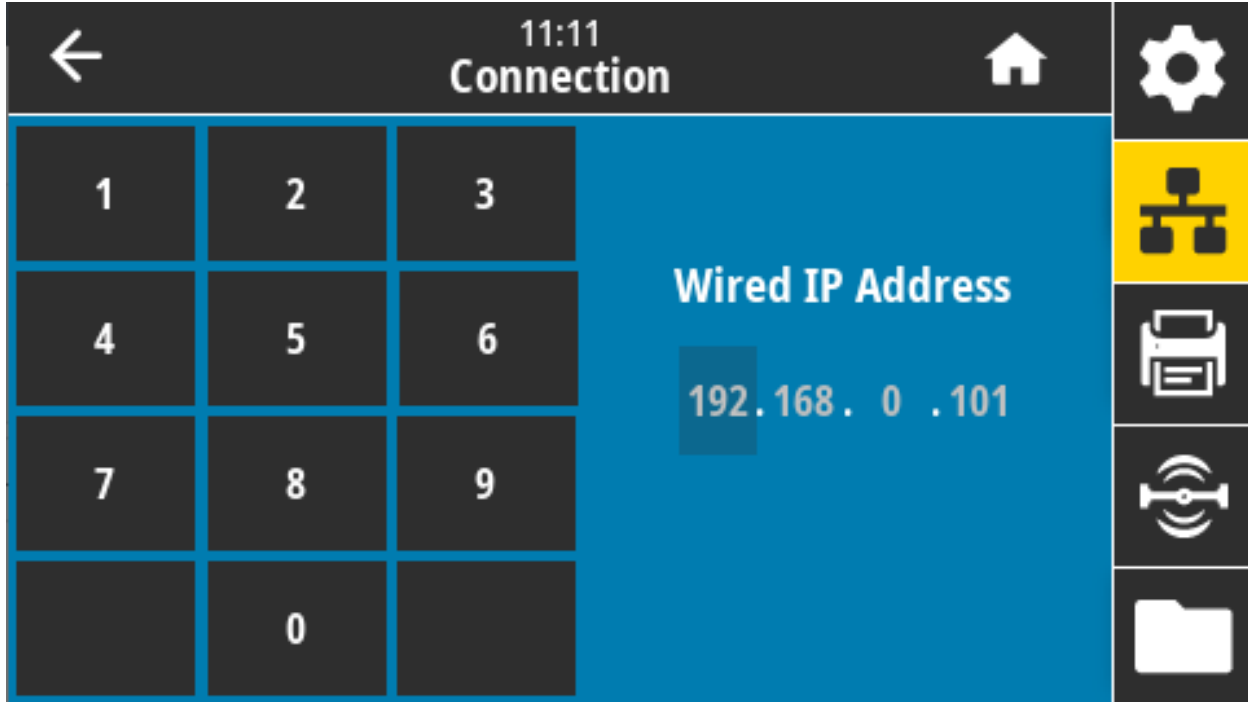

Accepted values: 000 to 255 for each field

Related ZPL command(s): ^ND

SGD command used: internal_wired.ip.addr

Printer web page: View and Modify Printer Settings > Network Communications Setup > TCP/IP Settings

Connection > Wired > Wired Gateway

View and, if necessary, change the default wired gateway.

To save changes to this setting, set Connection > Wired > Wired IP Protocol to PERMANENT, and then reset the print server (go to [Connection > Networks > Reset Network on page 90](#)).

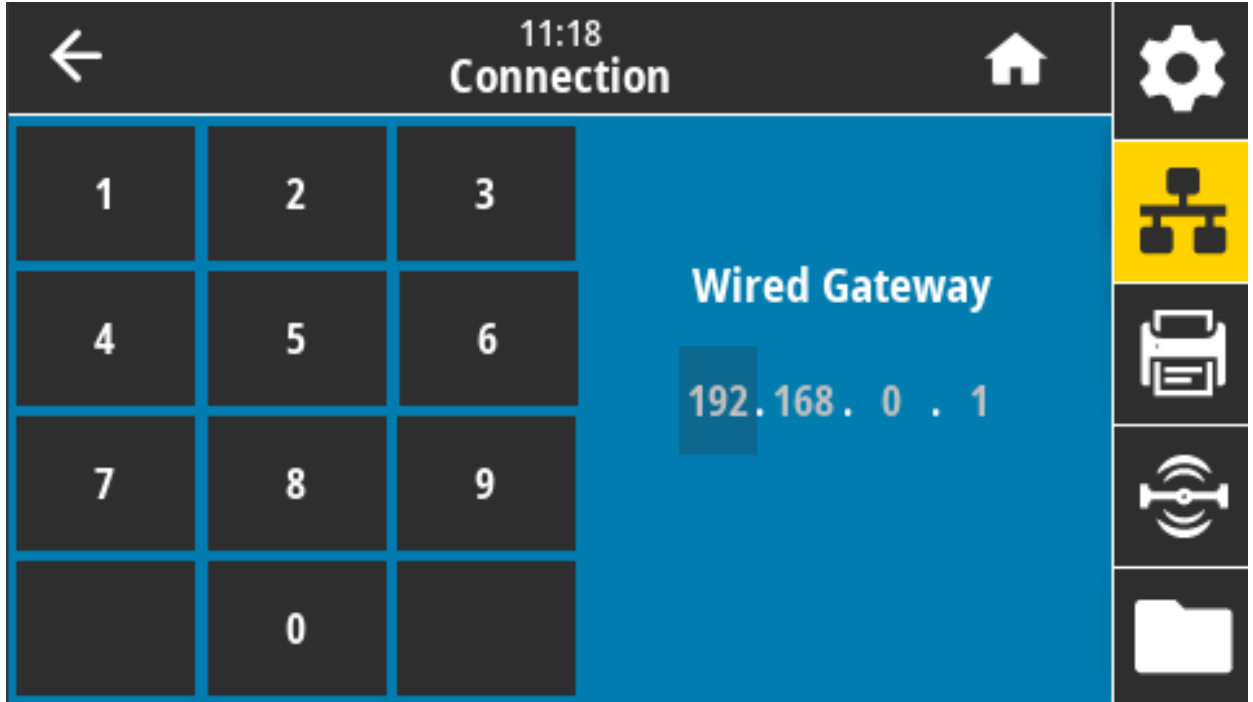

Accepted values: 000 to 255 for each field

Related ZPL command(s): ^ND

SGD command used: internal_wired.ip.gateway

Printer web page: View and Modify Printer Settings > Network Communications Setup > TCP/IP Settings

Connection > Wired > Wired Mac Address

View the Media Access Control (MAC) address of the wired print server. This value cannot be modified.

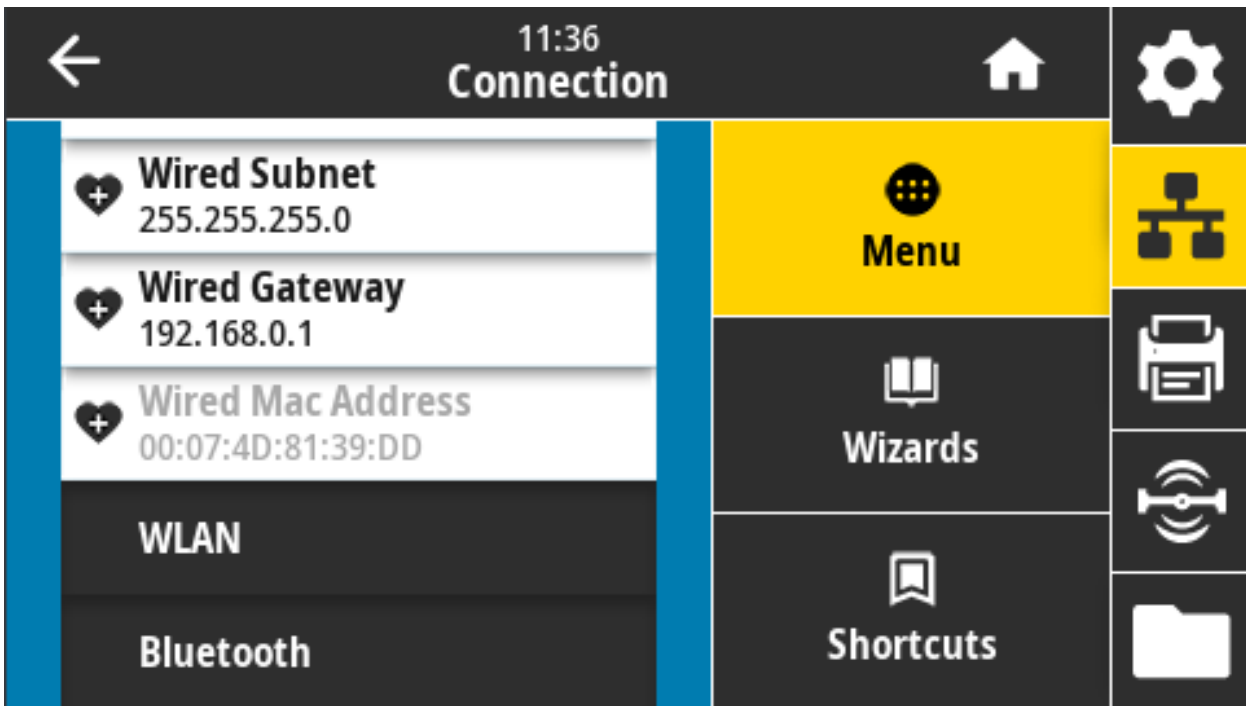

SGD command used: `internal_wired.mac_addr`

Printer web page: View and Modify Printer Settings > Network Communications Setup > TCP/IP Settings

Connection > WLAN > WLAN IP Protocol

This parameter indicates if the user (permanent) or the server (dynamic) selects the wireless print server's IP address. When a dynamic option is chosen, this parameter tells the method(s) by which this print server receives the IP address from the server.

You must reset the print server to allow changes to the network settings to take effect. Go to [Connection > Networks > Reset Network on page 90](#).

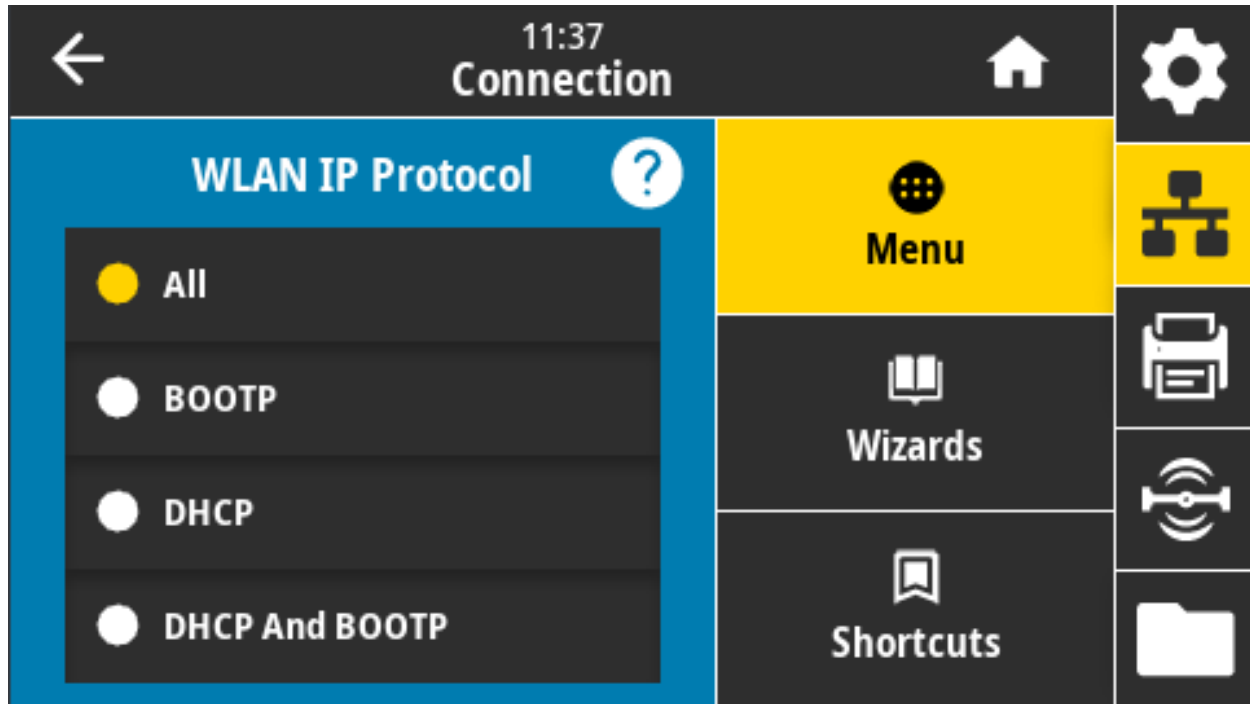

Accepted values: ALL, GLEANING ONLY, RARP, BOOTP, DHCP, DHCP & BOOTP, PERMANENT

Related ZPL command(s): ^ND

SGD command used: wlan.ip.protocol1

Printer web page: View and Modify Printer Settings > Network Communications Setup > Wireless Setup

Connection > WLAN > WLAN IP Address

View and, if necessary, change the printer's wireless IP address.

To save changes to this setting, set Connection > WLAN > WLAN IP Protocol to PERMANENT, and then reset the print server (go to [Connection > Networks > Reset Network on page 90](#)).

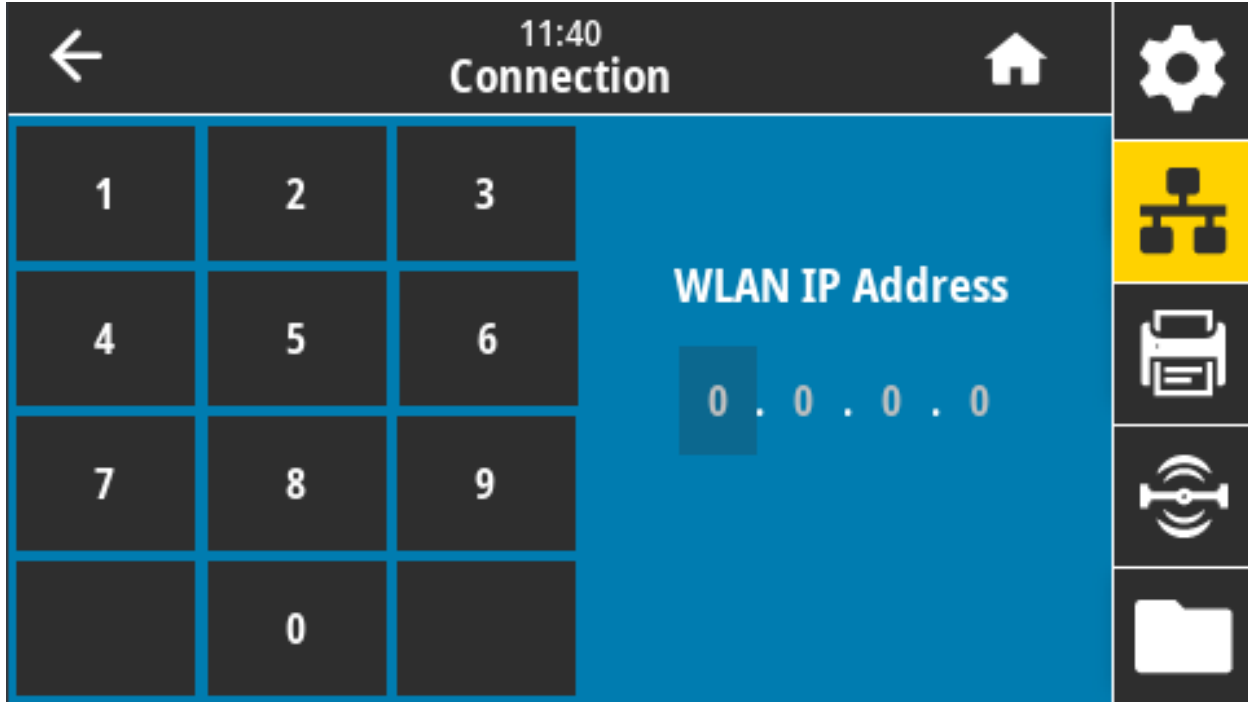

Accepted values: 000 to 255 for each field

Related ZPL command(s): ^ND

SGD command used: ip.addr, wlan.ip.addr

Printer web page: View and Modify Printer Settings > Network Communications Setup > Wireless Setup

Connection > WLAN > WLAN Subnet

View and, if necessary, change the wireless subnet mask.

To save changes to this setting, set Connection > WLAN > WLAN IP Protocol to PERMANENT, and then reset the print server (go to [Connection > Networks > Reset Network on page 90](#)).

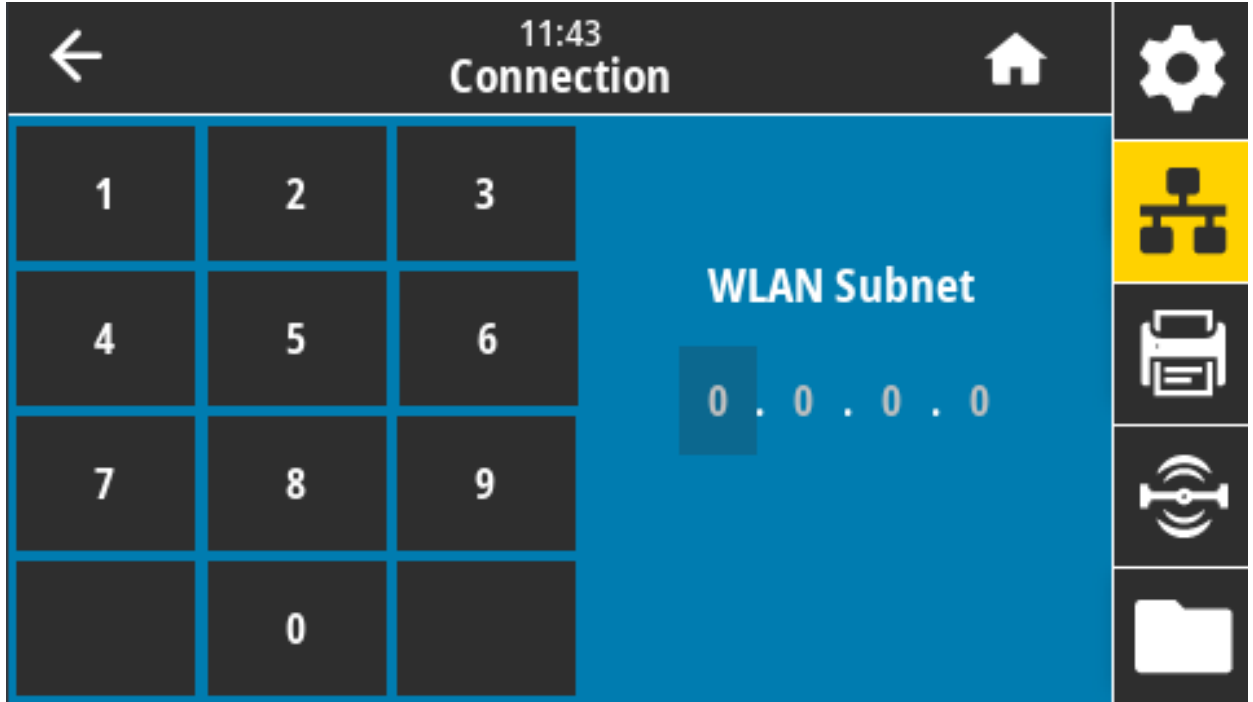

Accepted values: 000 to 255 for each field

Related ZPL command(s): ^ND

SGD command used: wlan.ip.netmask

Printer web page: View and Modify Printer Settings > Network Communications Setup > Wireless Setup

Connection > WLAN > WLAN Gateway

View and, if necessary, change the default wireless gateway.

To save changes to this setting, set Connection > WLAN > WLAN IP Protocol to PERMANENT, and then reset the print server (go to [Connection > Networks > Reset Network on page 90](#)).

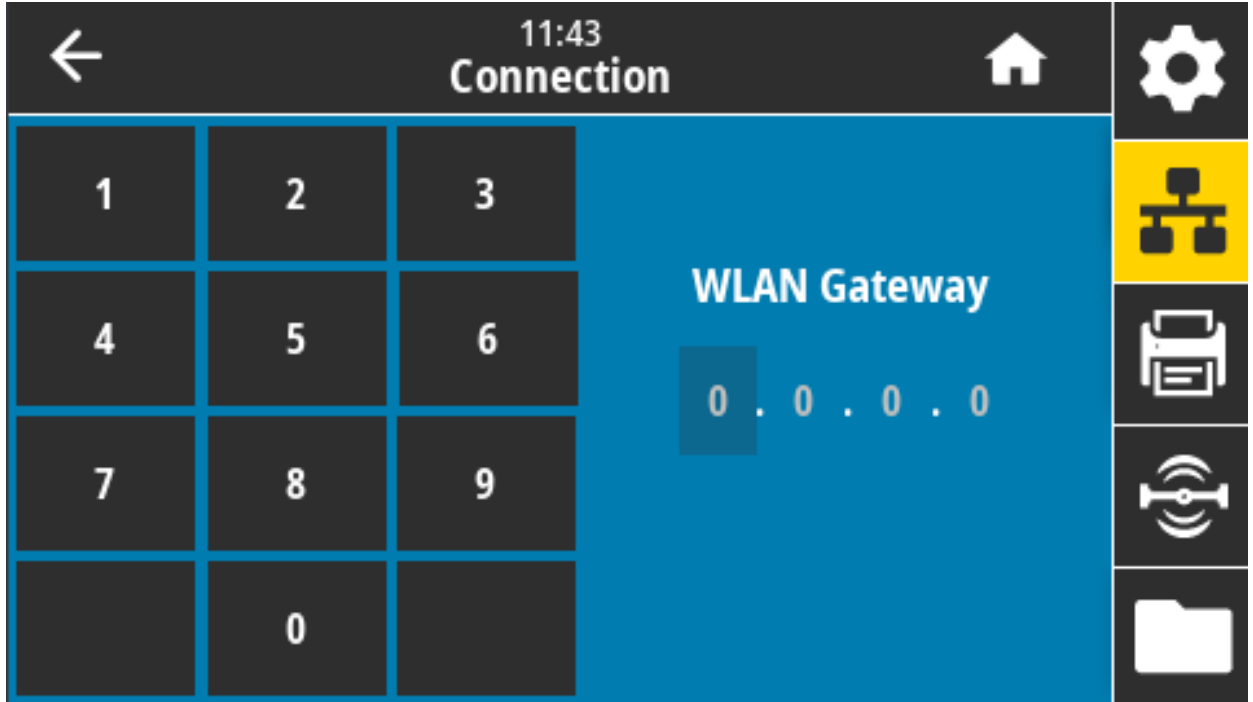

Accepted values: 000 to 255 for each field

Related ZPL command(s): ^ND

SGD command used: wlan.ip.gateway

Printer web page: View and Modify Printer Settings > Network Communications Setup > Wireless Setup

Connection > WLAN > WLAN Mac Address

View the Media Access Control (MAC) address of the wireless print server. This value cannot be modified.

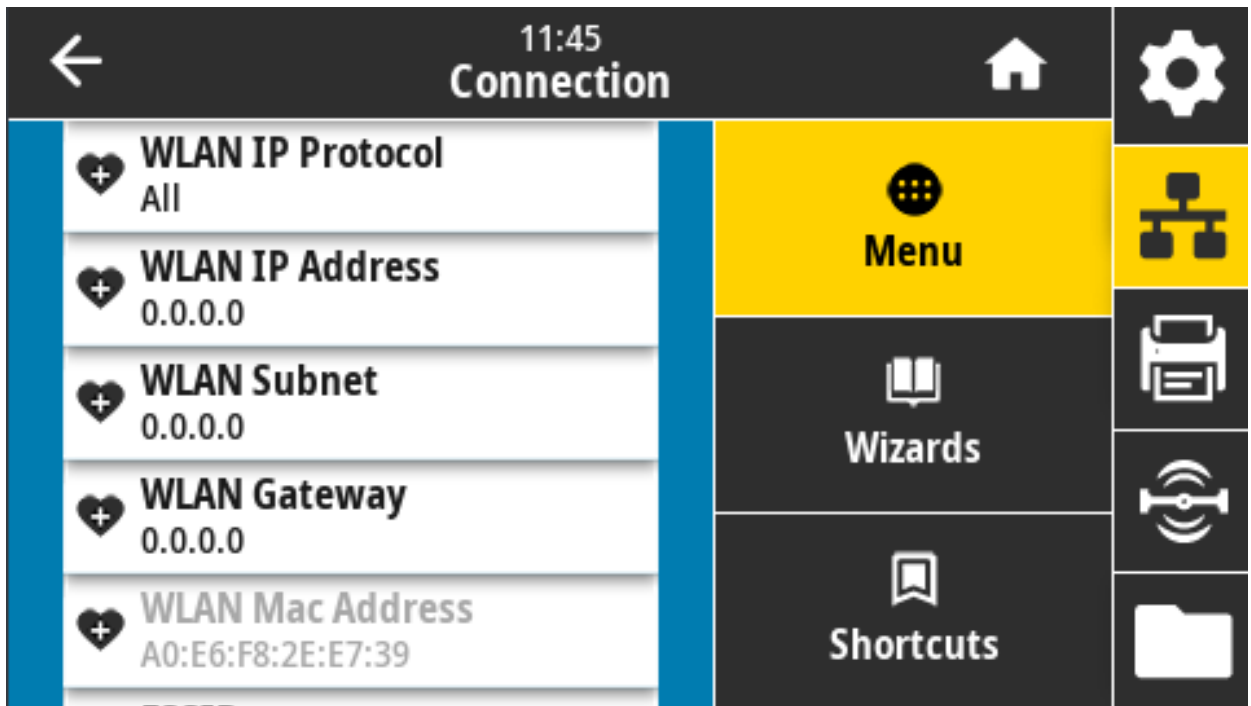

SGD command used: wlan.mac_addr

Printer web page: View and Modify Printer Settings > Network Communications Setup > Wireless Setup

Connection > WLAN > ESSID

The Extended Service Set Identification (ESSID) is an identifier for your wireless network. Specify the ESSID for the current wireless configuration.

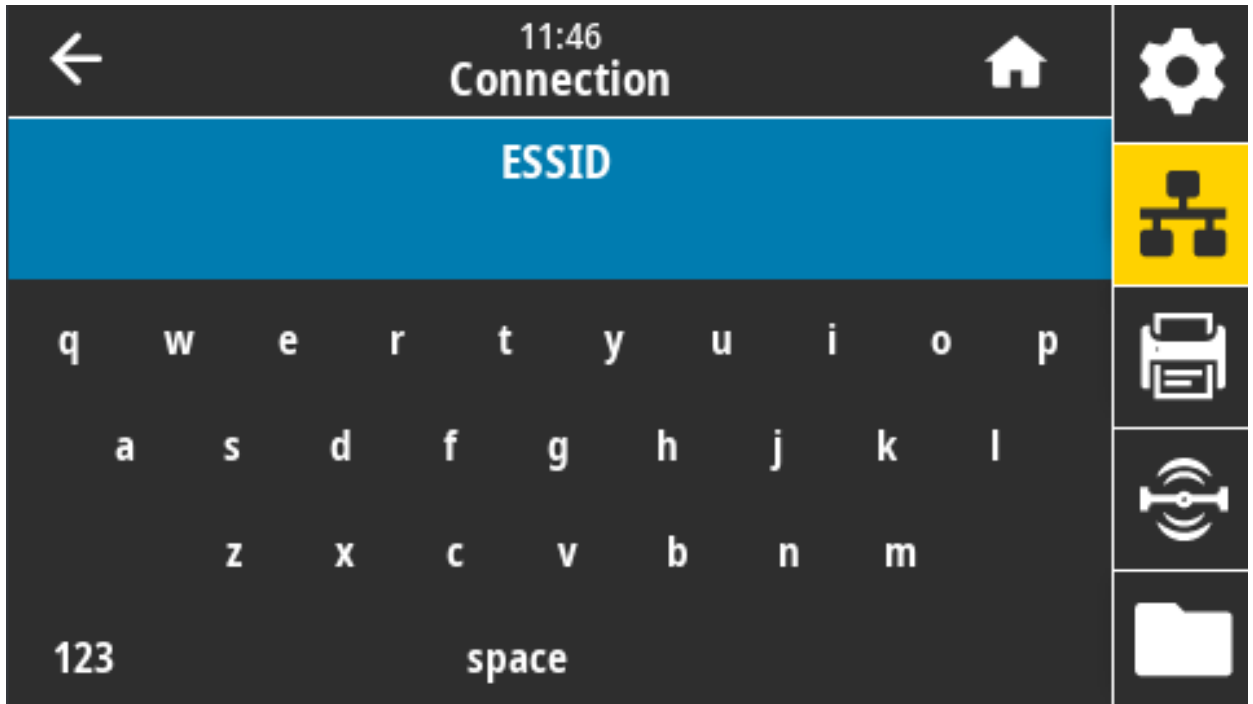

Accepted values: 32-character alphanumeric string (default 125)

SGD command used: wlan.essid

Printer web page: View and Modify Printer Settings > Network Communications Setup > Wireless Setup

Connection > WLAN > WLAN Security

Select the security type being used on your WLAN.

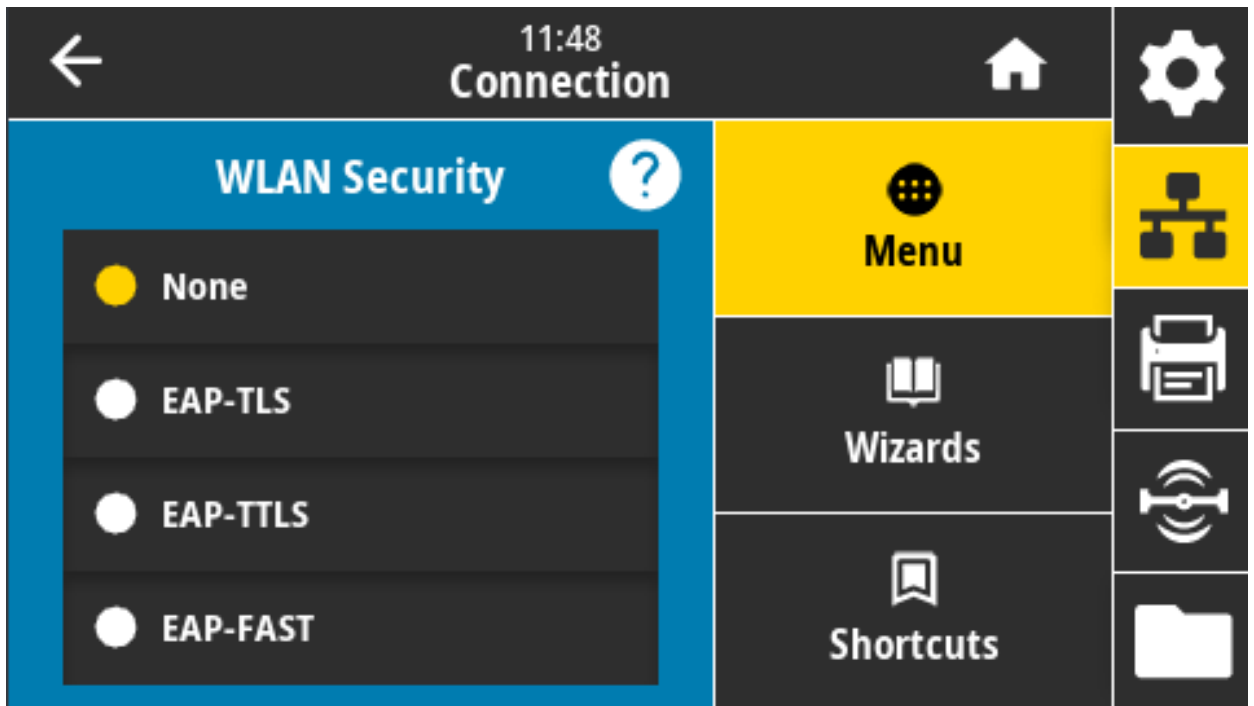

Related ZPL command(s): ^WX

SGD command used: wlan.security

Printer web page: View and Modify Printer Settings > Network Communications Setup > Wireless Encryption Setup

Connection > WLAN > WLAN Band

Set a preferred band to connect with via Wi-Fi.

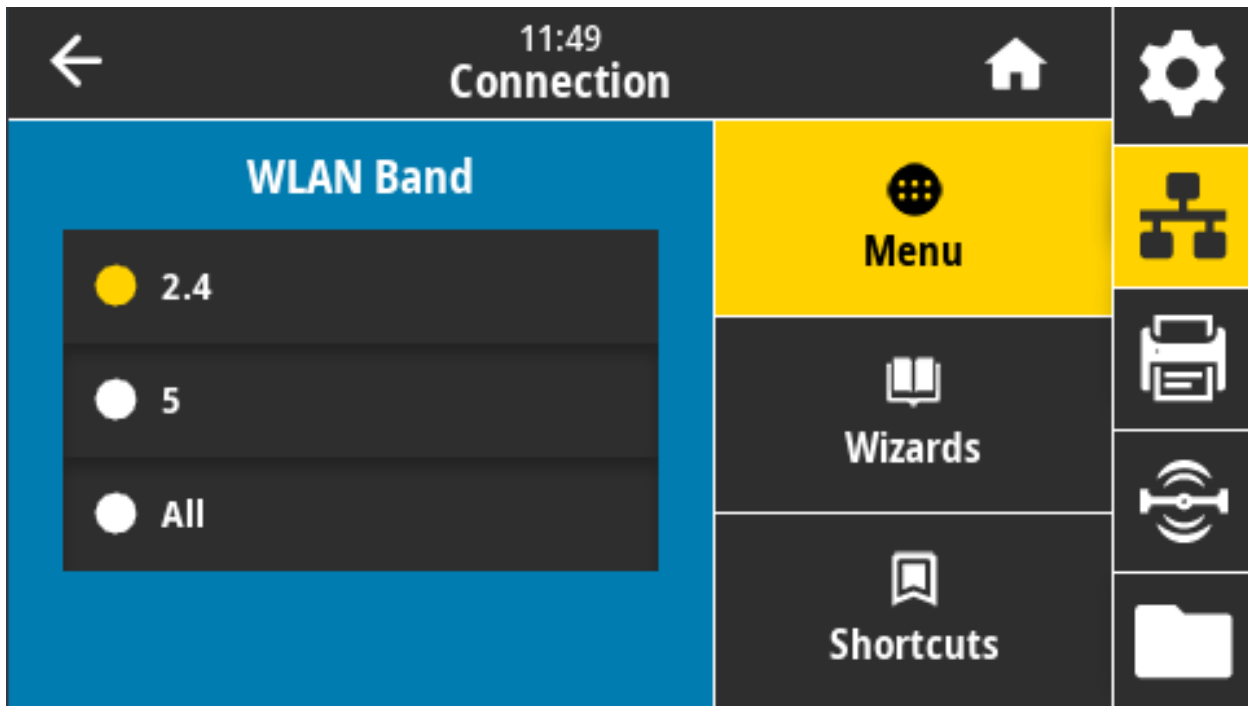

Accepted values: 2.4, 5, None

SGD command used: wlan.band_preference

Printer web page: View and Modify Printer Settings > Network Communications Setup > Wireless Setup

Connection > WLAN > WLAN Country Code

The country code defines the regulatory country for which the wireless radio is currently configured.

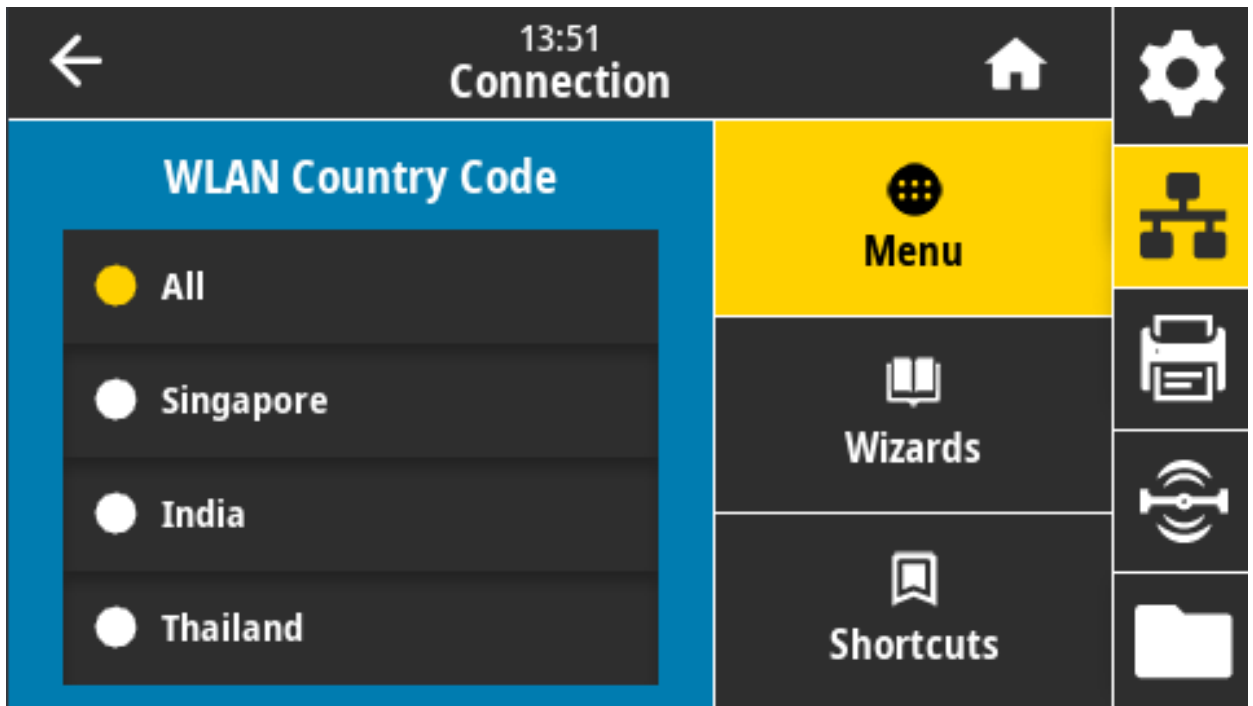

Note • The list of country codes is specific to each printer and depends on the printer model and its wireless radio configuration. The list is subject to change, addition, or deletion with any firmware update, at any time, without notice.

To determine the country codes available on your printer, issue the `! U1 getvar "wlan"` command to return all commands related to WLAN settings. Locate the `wlan.country.code` command in the results and view the country codes available for your printer.

SGD command used: `wlan.country_code`

Connection > Bluetooth > Bluetooth

Select if the printer is “Discoverable” for Bluetooth device pairing.

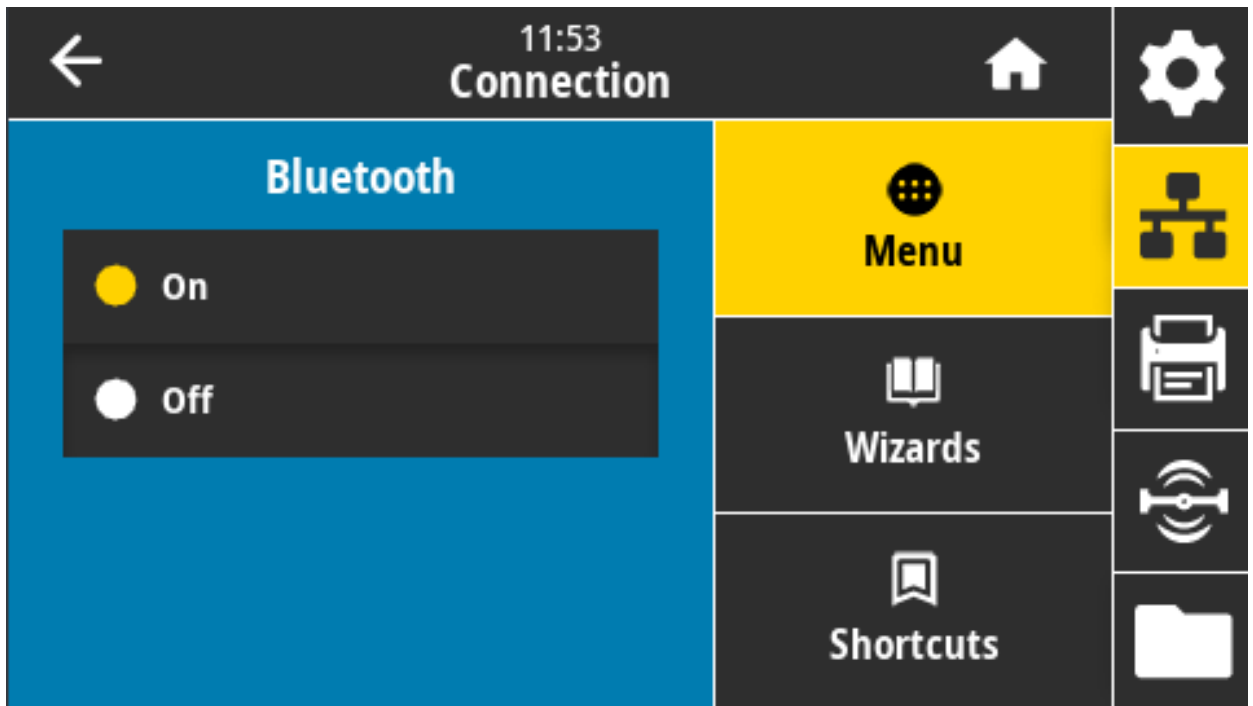

Accepted values:

ON—Enables the Bluetooth radio.

OFF—Disables the Bluetooth radio.

SGD command used: `bluetooth.enable`

Connection > Bluetooth > Bluetooth Discovery

Select if the printer is “Discoverable” for Bluetooth device pairing.

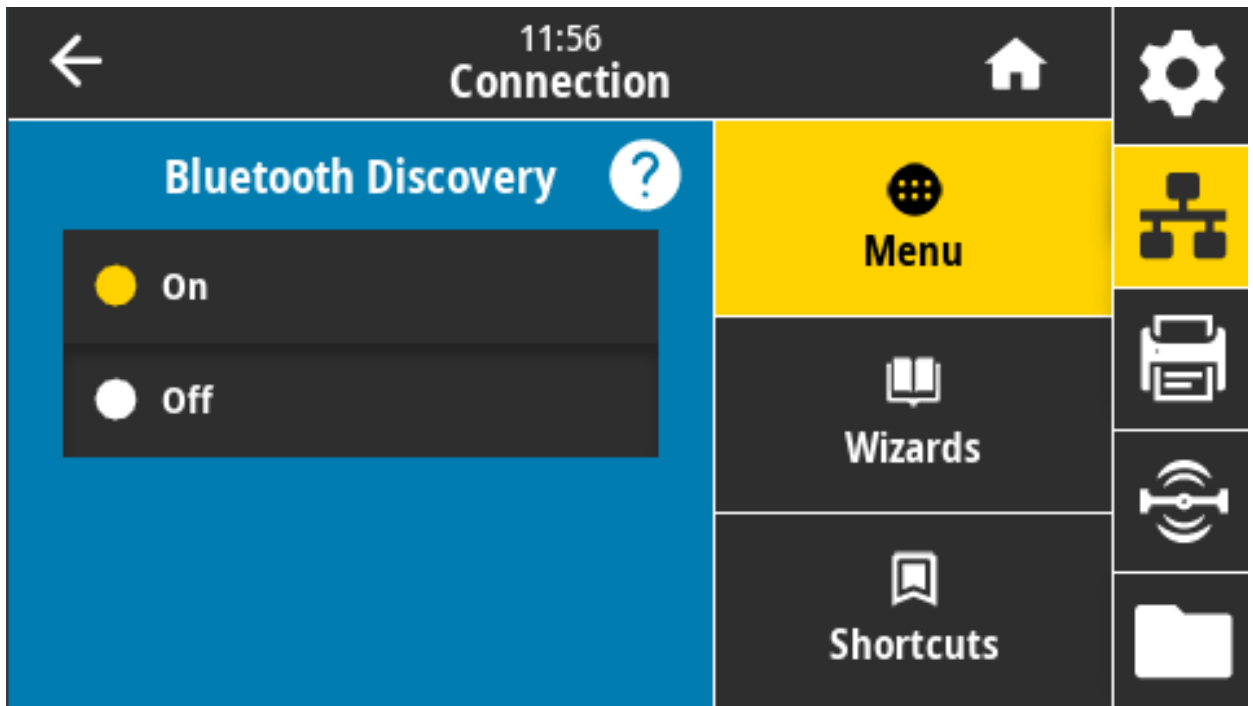

Accepted values:

ON—Enables Bluetooth discoverable mode.

OFF—Disables Bluetooth discoverable mode.

SGD command used: `bluetooth.discoverable`

Connection > Bluetooth > Friendly Name

This command sets the friendly name, which is used during service discovery.

For changes to take effect, you must power cycle the printer or issue the device.reset command (go to [Connection > Networks > Reset Network on page 90](#)).

If you do not set a friendly name, it will default to the printer serial number.



Accepted values: 17-character text string

SGD command used: `bluetooth.friendly_name`

Connection > Bluetooth > Minimum Security Mode

This printer setting parameter sets the Bluetooth Minimum Security mode. Minimum Security Mode provides for different levels of security, depending on the printer radio version and printer firmware.

Refer to the Zebra Programming Guide at zebra.com/manuals for more information.

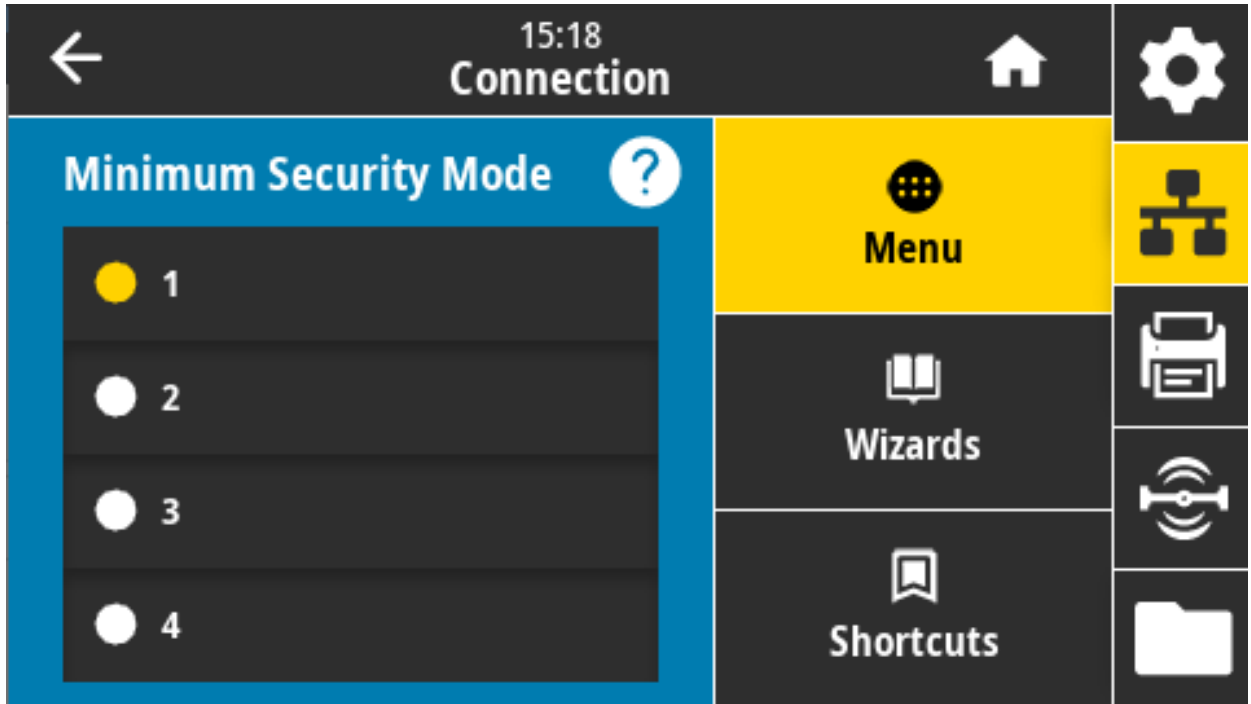

Accepted values: 1, 2, 3, 4

SGD command used: `bluetooth.minimum_security_mode`

Connection > Bluetooth > Specification Version

This parameter displays the Bluetooth library version number.

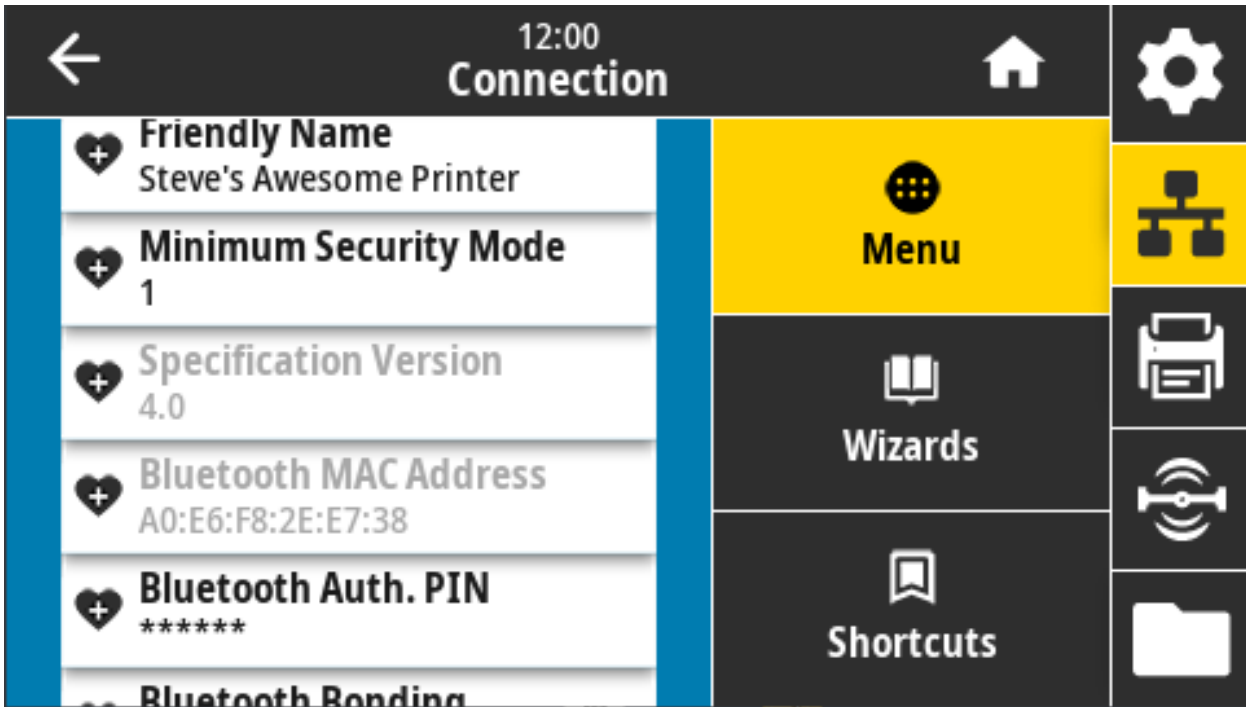

SGD command used: bluetooth.version

Connection > Bluetooth > MAC Address

This parameter displays the Bluetooth device address.

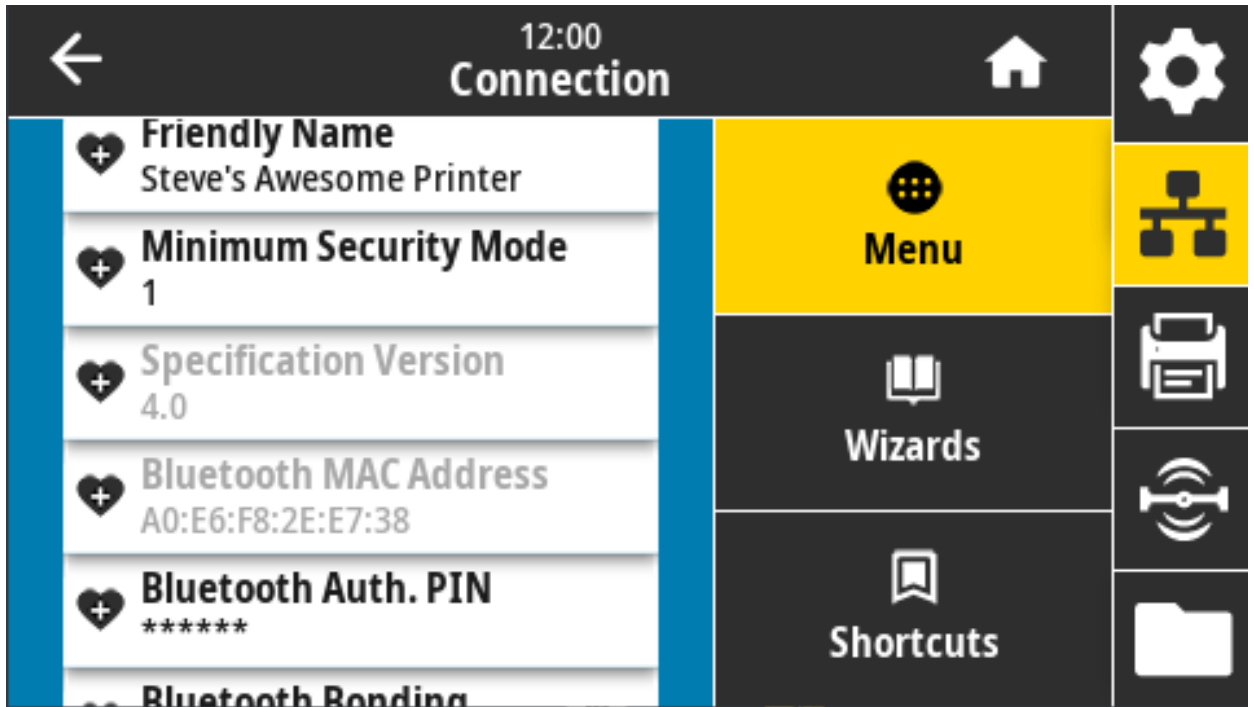

SGD command used: bluetooth.address

Connection > Bluetooth > Bluetooth Auth. PIN

This parameter displays the Bluetooth device address.

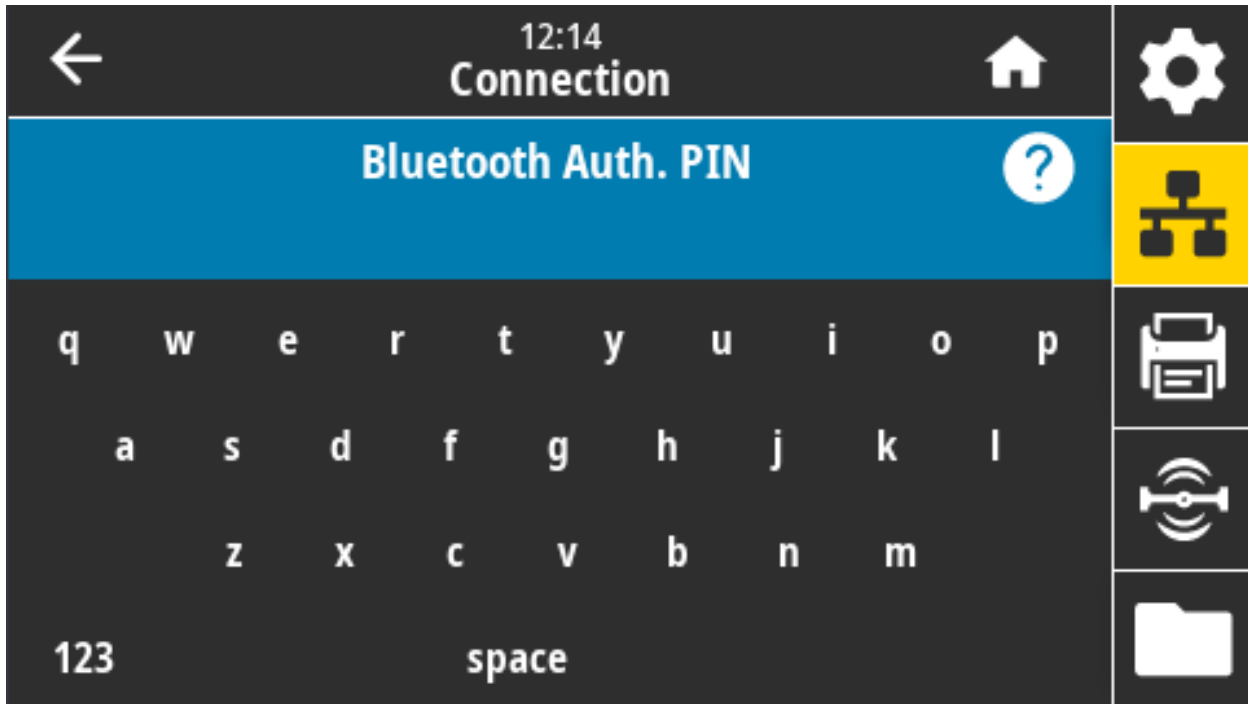

SGD command used:

`bluetooth.bluetooth_pin` (to set the PIN)

`bluetooth.authentication` (to enable authentication)

Connection > Bluetooth > Bluetooth Bonding

Controls whether the Bluetooth stack will “bond” or save link keys for devices that successfully connect to the printer.

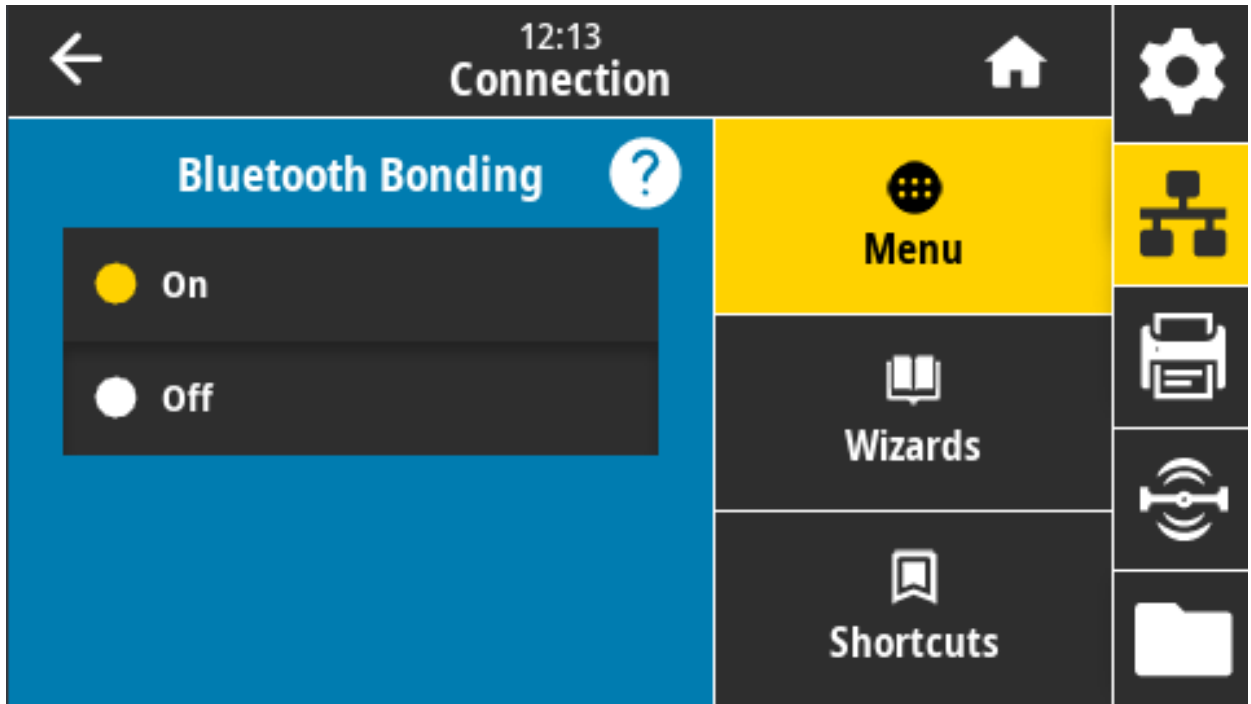

Accepted values:

ON—Enables Bluetooth bonding.

OFF—Disables Bluetooth bonding.

SGD command used: `bluetooth.bonding`

Print Menu

Use this menu to set how the printer prints. Set darkness, speed, size, handling the print job, etc.

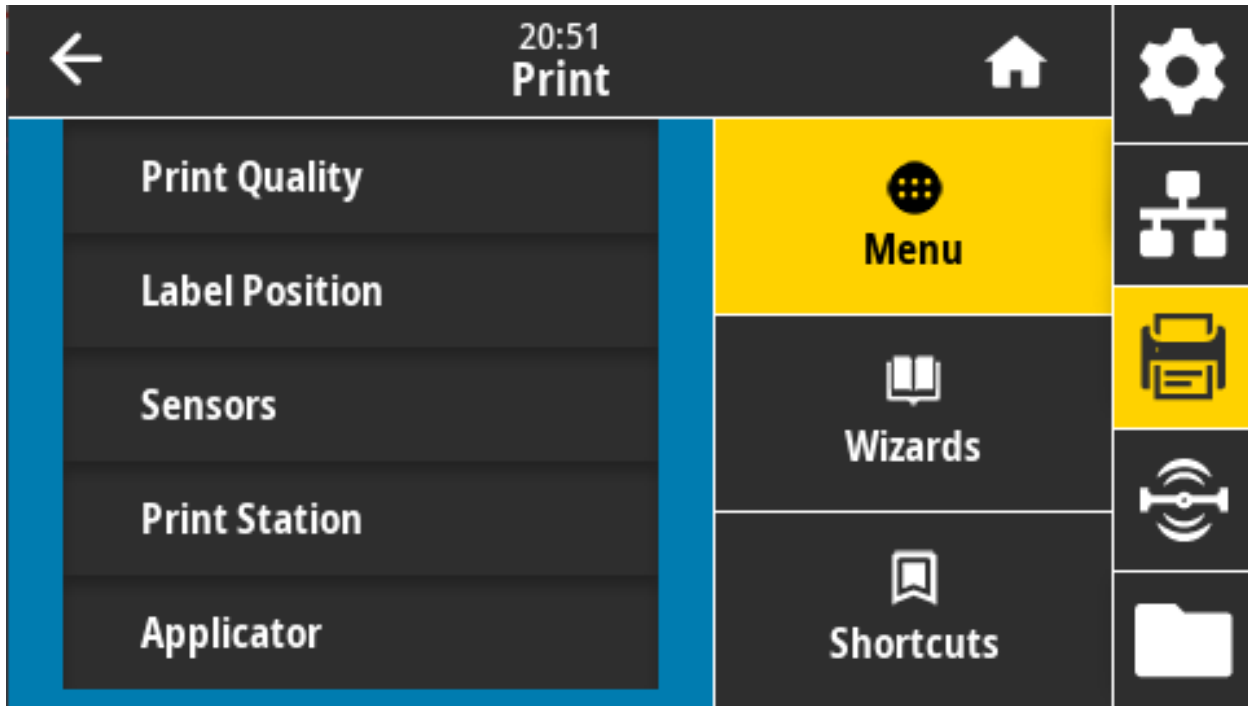

Print > Print Quality > Darkness

Set the print darkness to the lowest setting that provides good print quality. If you set the darkness too high, the label image may print unclearly, barcodes may not scan correctly, the ribbon may burn through, or the printhead may wear prematurely.

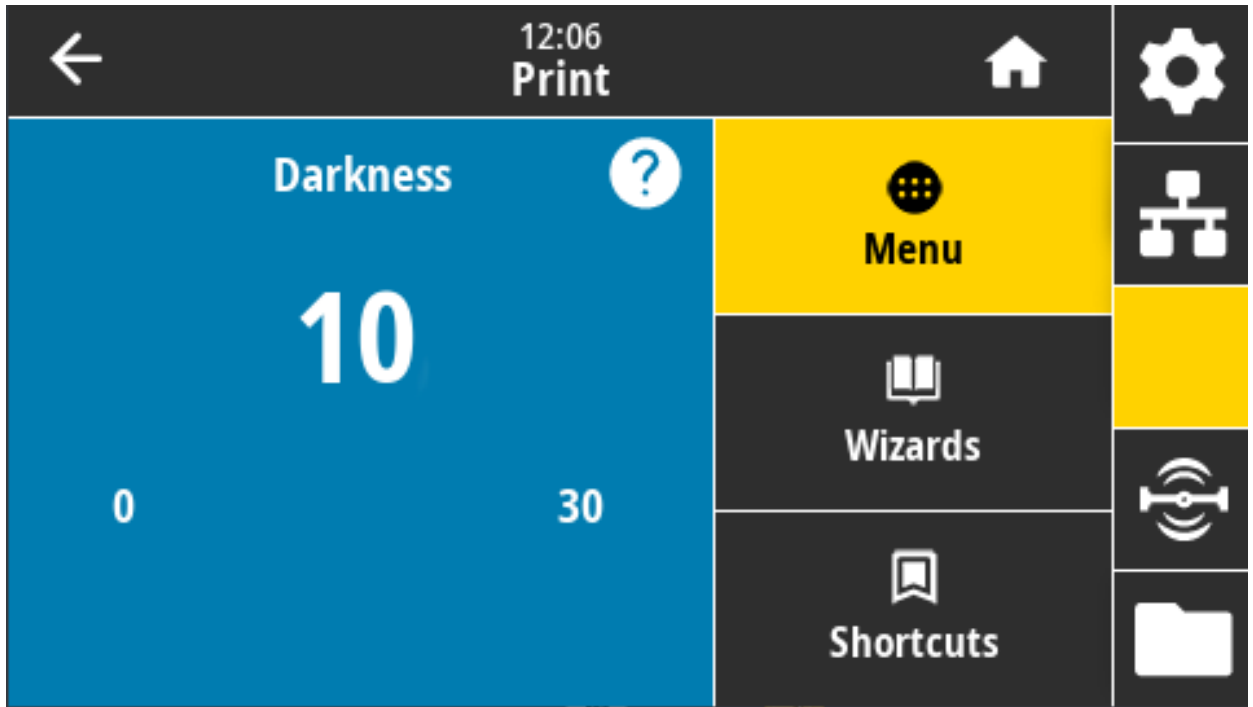

Accepted values: 0.0 to 30.0

Related ZPL command(s):

^MD

~SD

SGD command used: print.tone

Printer web page: View and Modify Printer Settings > General Setup > Darkness

Print > Print Quality > Print Speed

Select the speed in inches per second (ips), for printing a label. Slower print speeds typically yield better print quality.

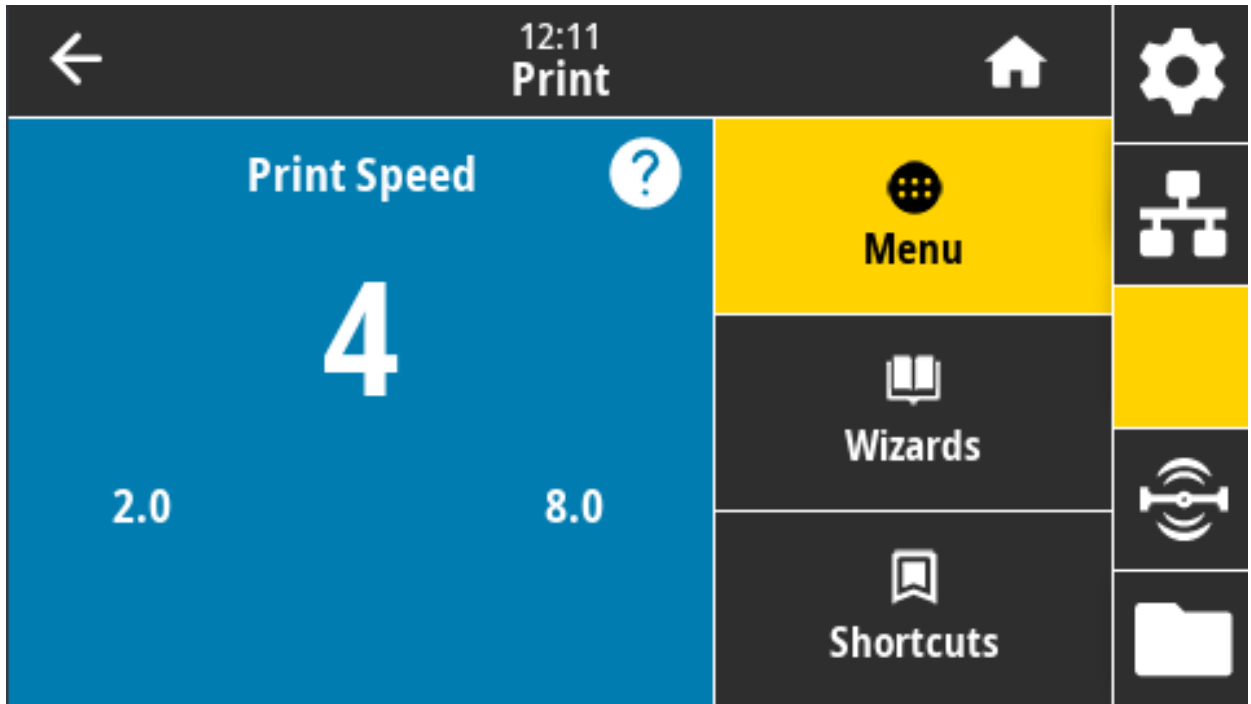
**Accepted values:**

ZD621 203 dpi = 2 to 8 ips

ZD621 300 dpi = 2 to 6 ips

Related ZPL command(s): ^PR

SGD command used: media.speed

Printer web page: View and Modify Printer Settings > General Setup > Print Speed

Print > Print Quality > Print Type

Specify if the printer needs to use ribbon for printing.

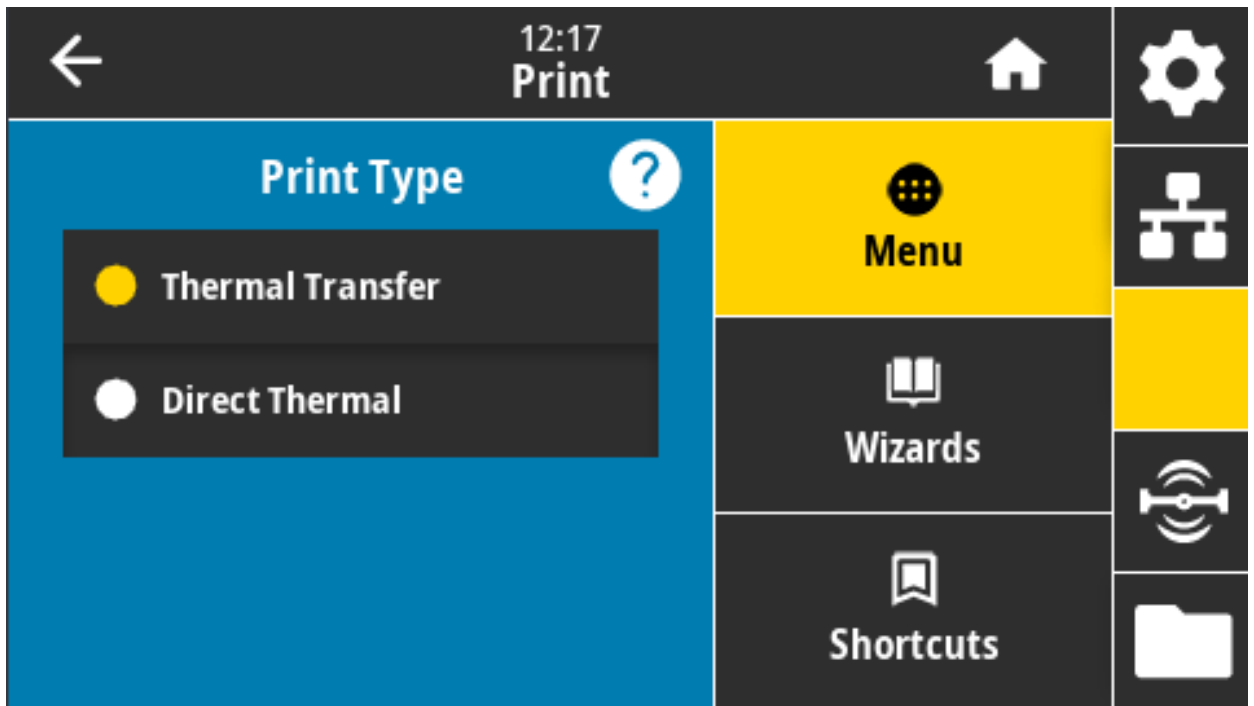
**Accepted values:**

Thermal Transfer—Uses ribbon and thermal transfer media.

Direct Thermal—Uses direct thermal media and no ribbon.

Related ZPL command(s): ^MT

SGD command used: ezpl.print_method

Printer web page: View and Modify Printer Settings > Media Setup > Print Method

Print > Print Quality > Label Type

Select the type of media that you are using.

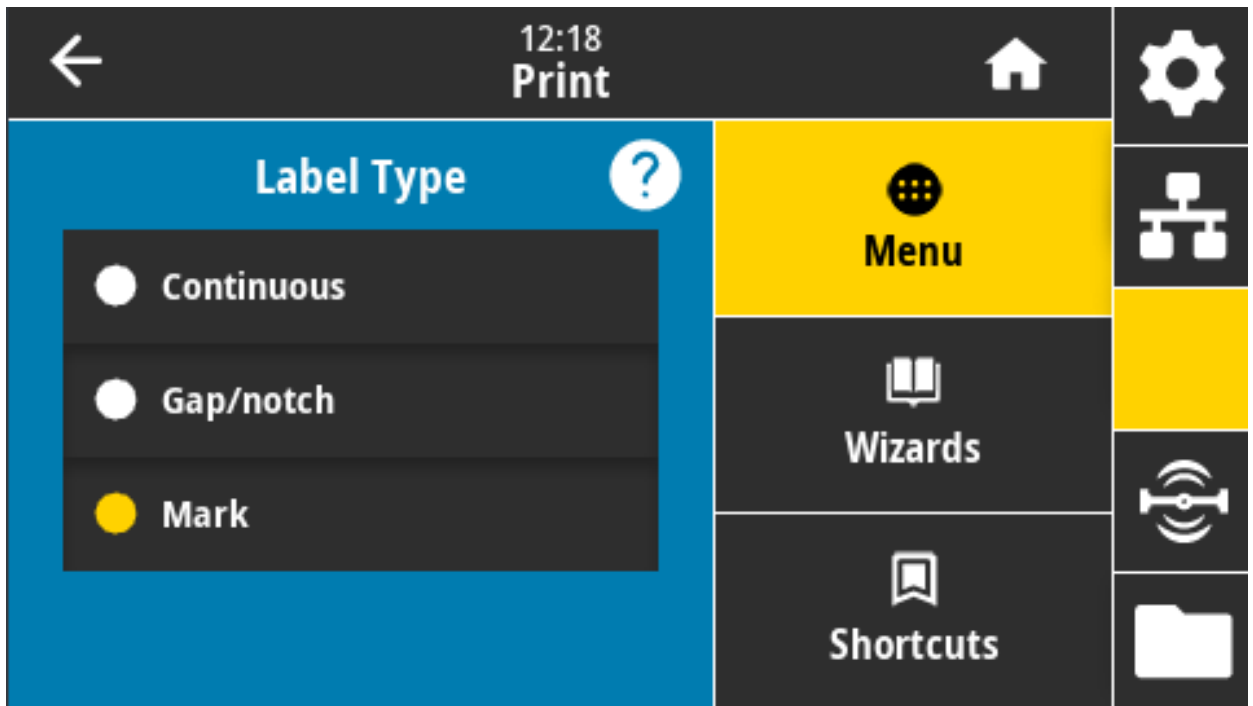

If you select Continuous, you must include a label length (set with Print > Print Quality > Label Length) in your label format layout (^LL if you are using ZPL).

If you select Gap/Notch or Mark for various noncontinuous media, the printer feeds media to calculate the label length.

Accepted values: Continuous, Gap/Notch, Mark

Related ZPL command(s): ^MN

SGD command used: ezpl.media_type

Printer web page: View and Modify Printer Settings > Media Setup > Media Type

Print > Print Quality > Label Length

View the calibrated label length in dots. This value cannot be modified.

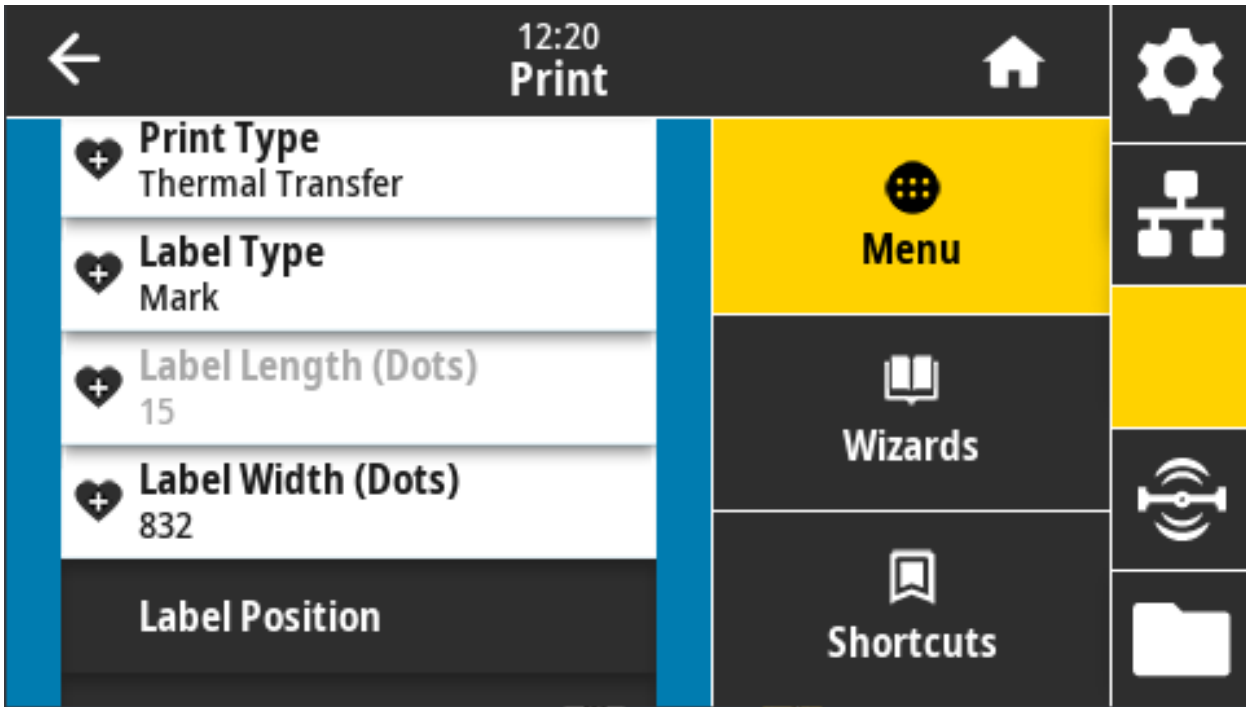

Print > Print Quality > Label Width (Dots)

Specify the width of the labels being used, in dots. The default value is the maximum width for the printer, based on the printhead's DPI value.



NOTE: Setting the width too narrow can result in portions of a label format not being printed on the media. Setting the width too wide wastes formatting memory and can cause the printer to print off of the label and onto the platen roller. This setting can affect the horizontal position of the label format if the image was inverted using the **^POI** ZPL command.

Accepted values:

ZD621 203 dpi = 0002 to 832 dots

ZD621 300 dpi = 0002 to 1280* dots

Related ZPL command(s): **^PW**

SGD command used: **ezpl.print_width**

Printer web page: View and Modify Printer Settings > Media Setup > Print Width

Print > Label Position > Collection Method

Select a collection method that is compatible with the options available on your printer.

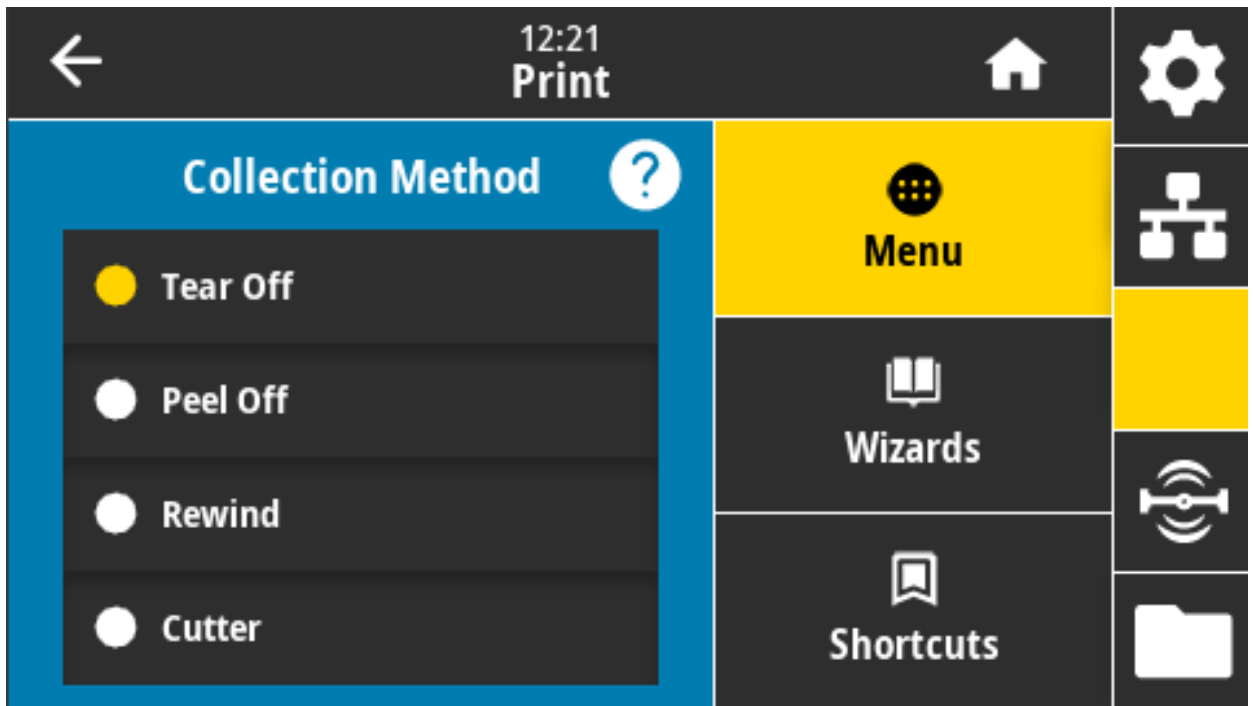

Accepted values: Tear Off, Peel Off, Rewind, Cutter, Delayed Cut, Linerless Peel, Linerless Rewind, Linerless Tear, Applicator, Linerless Cut, Linerless Delayed Cut

Related ZPL command(s): ^MM

SGD command used: media.printmode

Printer web page: View and Modify Printer Settings > General Setup > Print Mode

Print > Label Position > Tear Line Offset

Set the position where the printer stops for tear-off label removal.

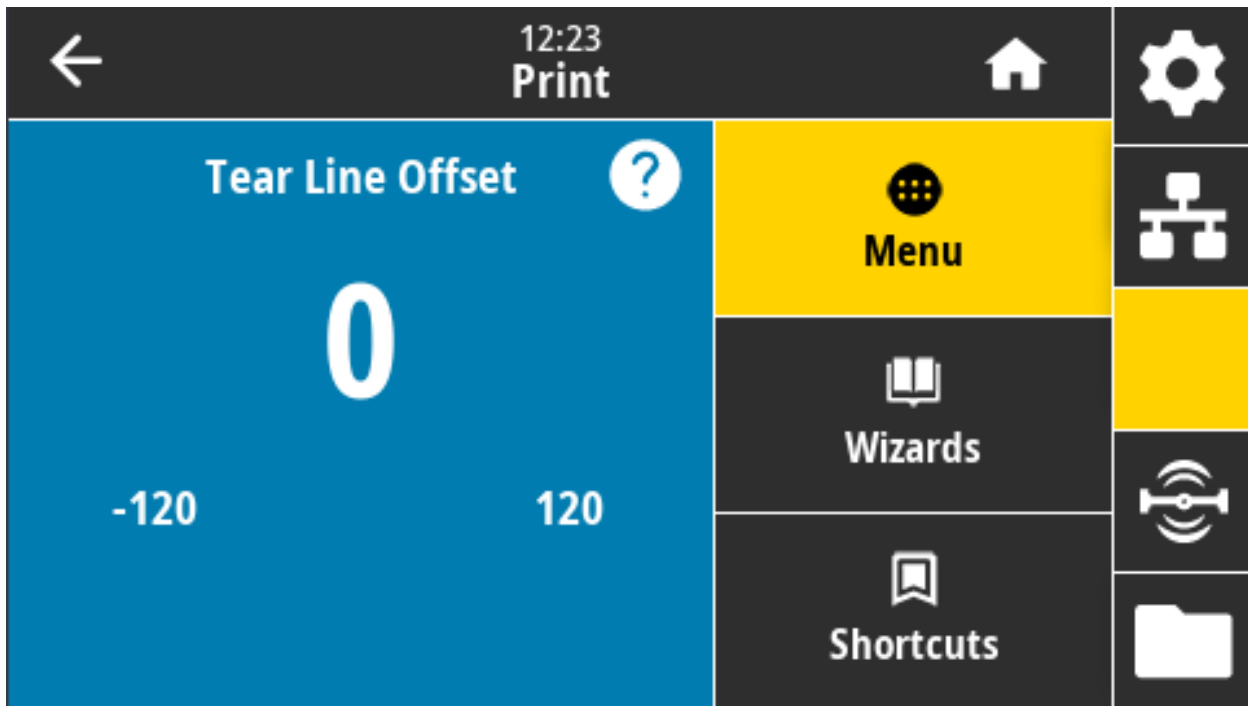

If necessary, shift the position of the media over the tear-off feature after printing.

- Lower numbers move the media into the printer by the specified number of dots (the tear line moves closer to the edge of the label just printed).
- Higher numbers move the media out of the printer (the tear line moves closer to the leading edge of the next label).

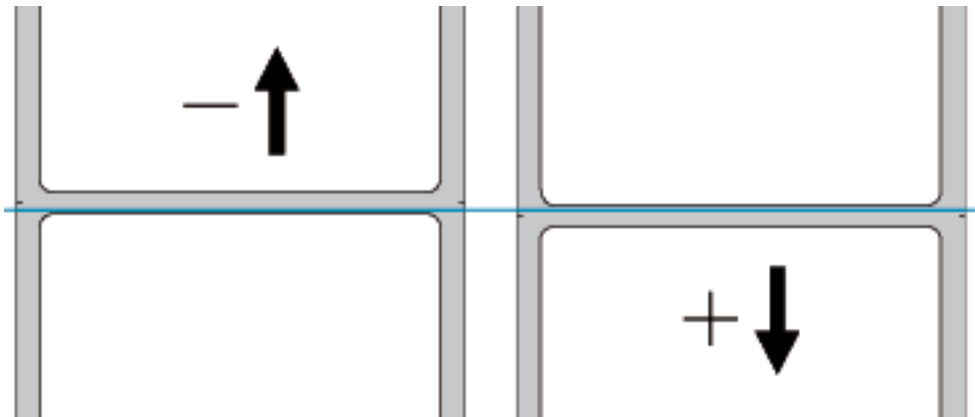

Accepted values: -120 to +120

Related ZPL command(s): ~TA

SGD command used: media.printmode

Printer web page: View and Modify Printer Settings > General Setup > Tear Off

Print > Label Position > Horizontal Label Offset

If necessary, shift the position of the image horizontally on the label.

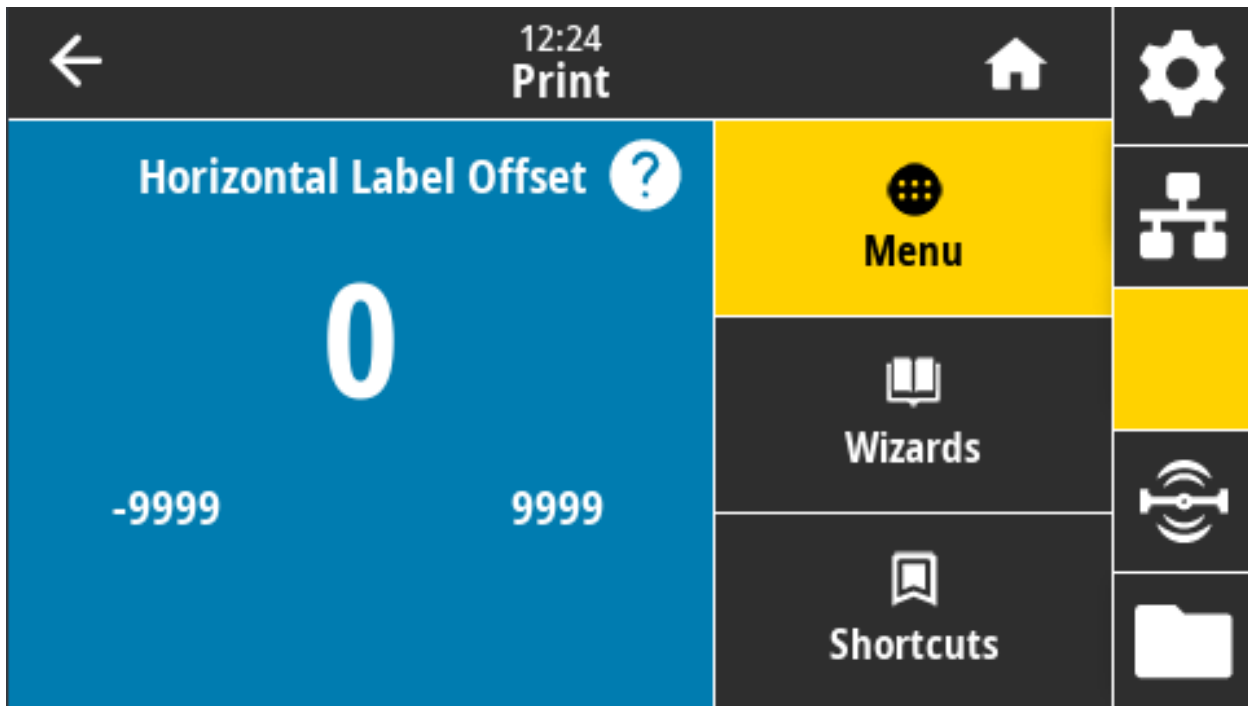

If necessary, shift the horizontal position of the print on the media.

- Negative numbers move the left edge of the image toward the left edge of the label by the number of dots selected.
- Positive numbers move the edge of the image toward the right edge of the label.

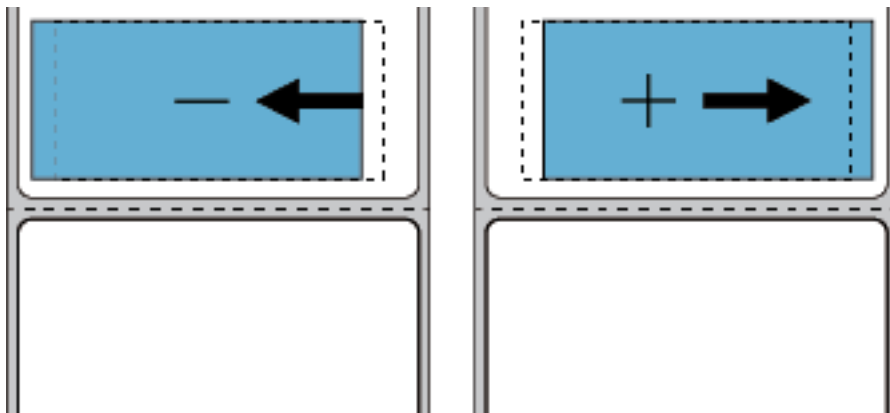

Accepted values: -9999 to 9999

Related ZPL command(s): ^LS

SGD command used: zp1.left_position

Printer web page: View and Modify Printer Settings > Advanced Setup > Left Position

Print > Label Position > Vertical Label Offset

If necessary, shift the position of the image vertically on the label.

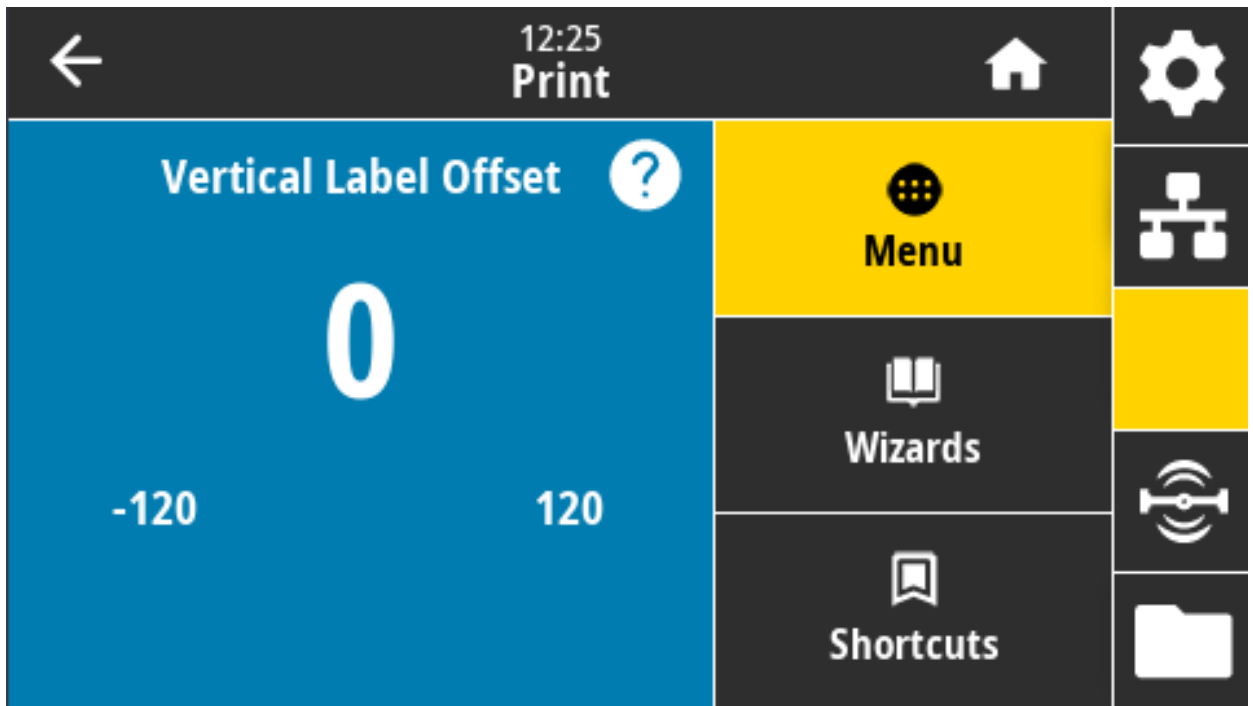

If necessary, shift the position horizontal of the print on the media.

- Lower numbers move the image higher on the label (toward the printhead).
- Higher numbers move the image farther down on the label (away from the printhead) by the specified number of dots.

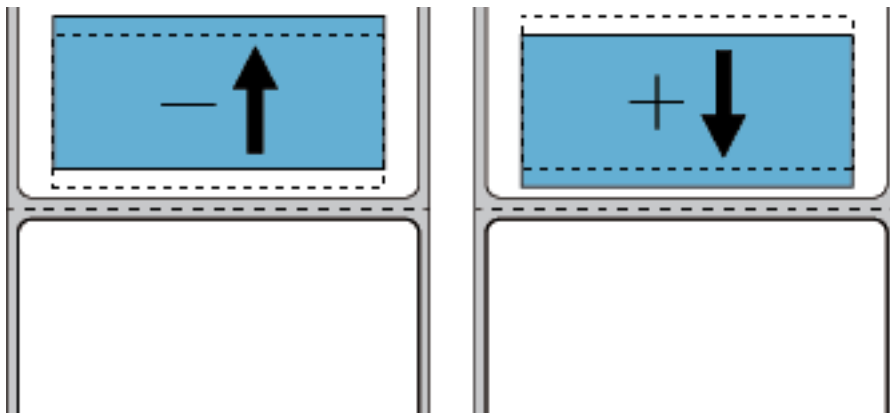

Accepted values: -120 to 120

Related ZPL command(s): ^LT

SGD command used: zpl.top_position

Printer web page: View and Modify Printer Settings > Advanced Setup > Label Top

Print > Sensors > Manual Calibration

Calibrate the printer to adjust the sensitivity of the media and ribbon sensors. This operation is a Wizard that interactively steps you through a manual calibration of media sensor settings.

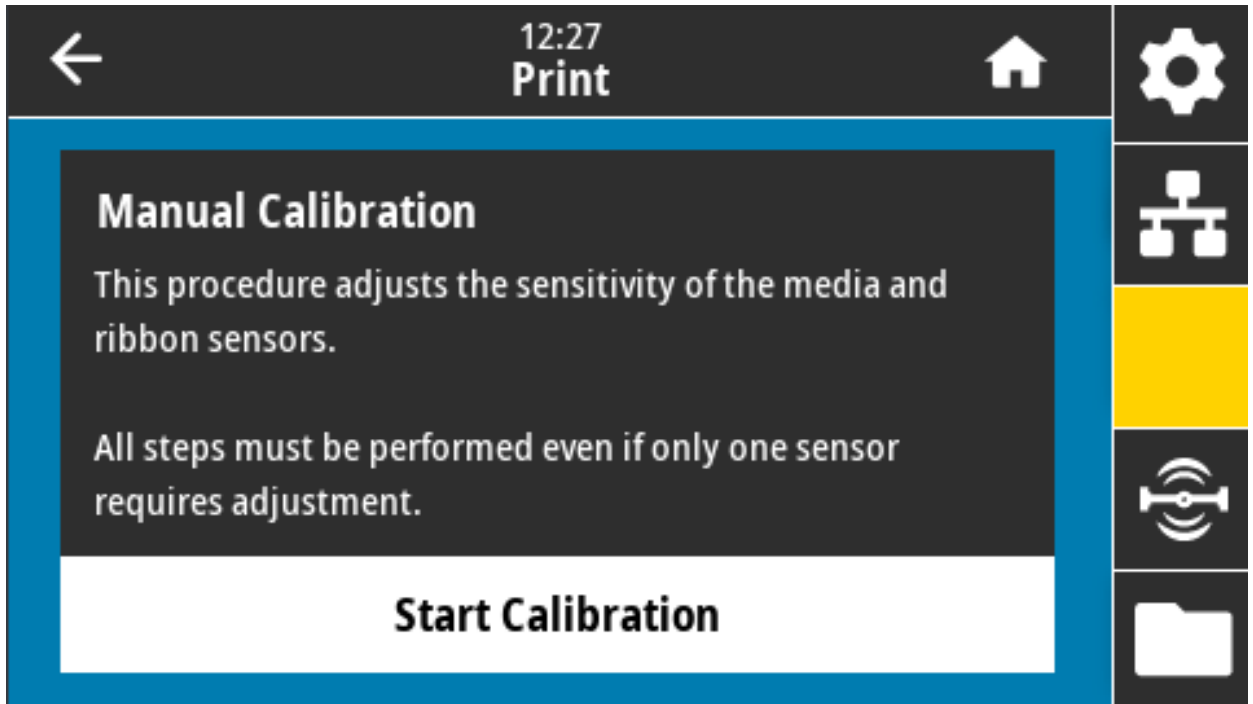

For complete instructions on how to perform a calibration procedure, go to [Manual Media Calibration on page 303](#).

Related ZPL command(s): ~JC

SGD command used: ezpl.manual_calibration

Control panel key(s): Hold **PAUSE + FEED + CANCEL** for 2 seconds to initiate calibration.

Print > Sensors > Label Sensor

Set the sensitivity of the label sensor.

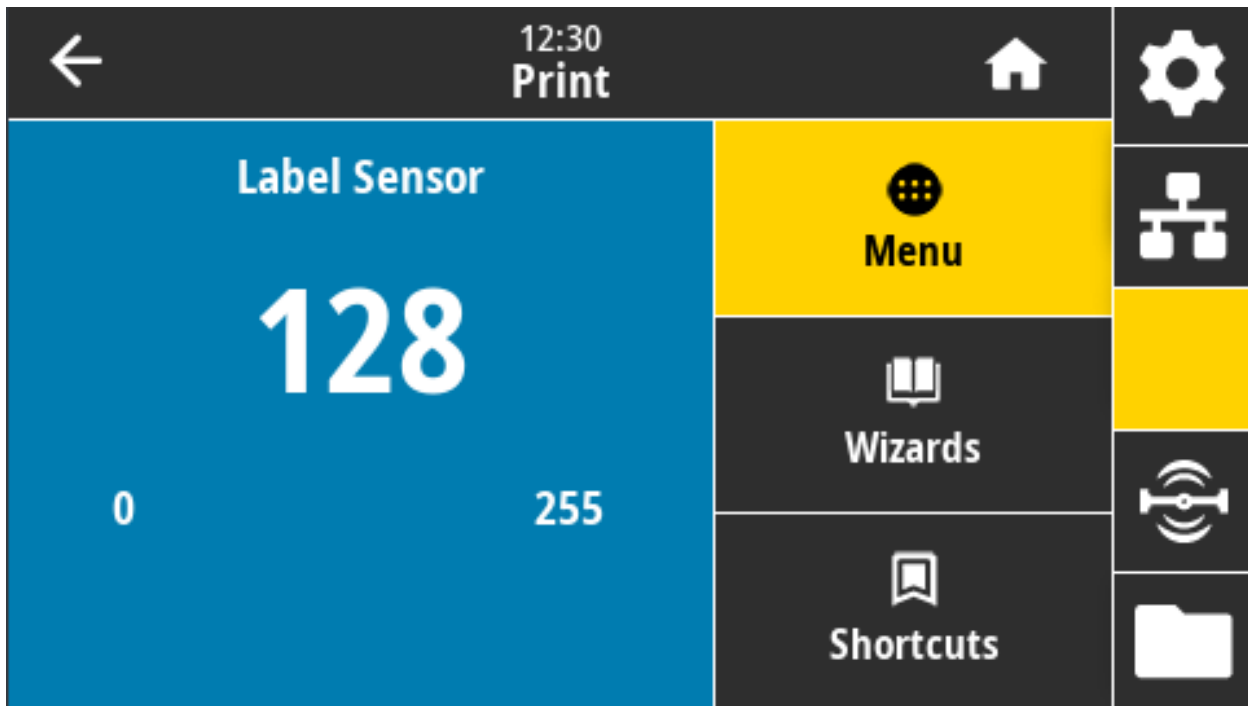

NOTE: This value is set during sensor calibration. Do not change these settings unless you are told to do so by Zebra Technical Support or by an authorized service technician.

Accepted values: 0 to 255

SGD command used: `ezp1.label_sensor`

Printer web page: View and Modify Printer Settings > Calibration

Print > Sensors > Sensor Type

Select between transmissive and reflective media sensing that is appropriate for the media type that you are using.

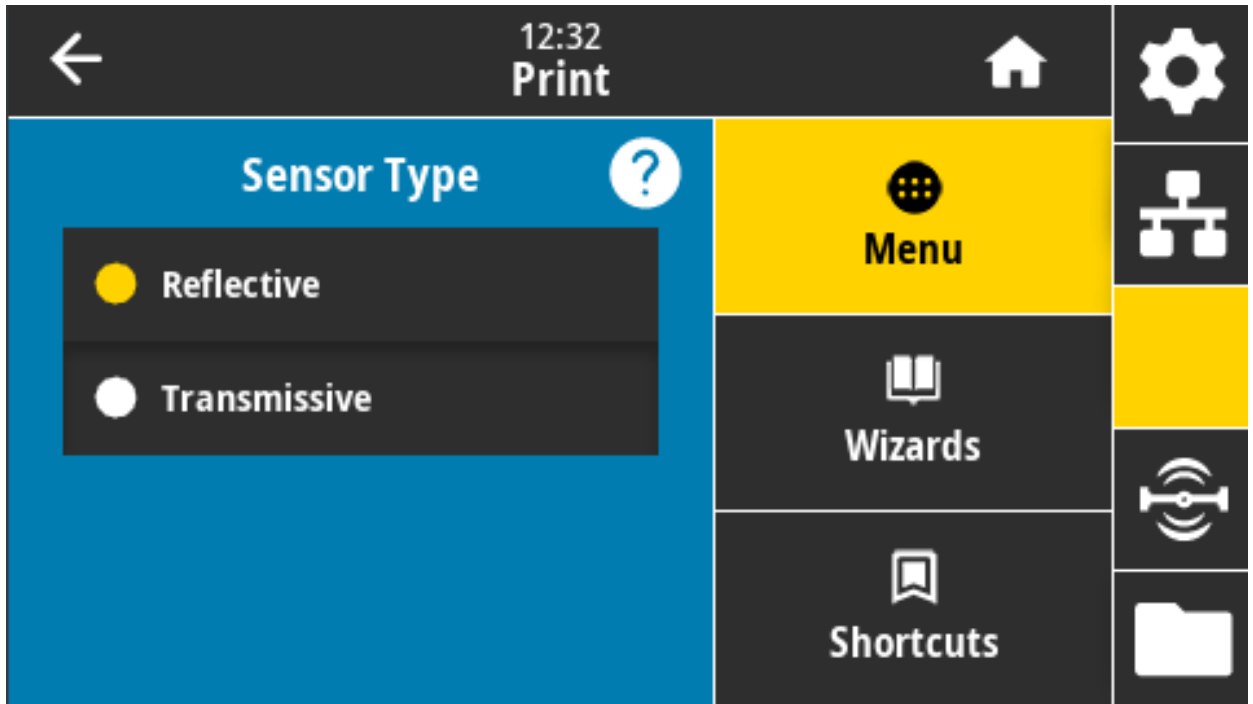

Transmissive (sees-through media and liner) — Used for gap/web sensing for common labels and continuous media. No tracking marks or notches on these medias.

Reflective — Used for the detection of black mark/line and notches/holes on the backside of media. Black markings and holes do not reflect like the liner or paper.

Accepted values: TRANSMISSIVE, REFLECTIVE

Related ZPL command(s): ^JS

SGD command used: device.sensor_select

Printer web page: View and Modify Printer Settings > Media Setup

Print > Sensors > Print: Sensor Profile

Shows the sensor settings compared to actual sensor readings. To interpret the results, go to [Sensor Profile on page 302](#).

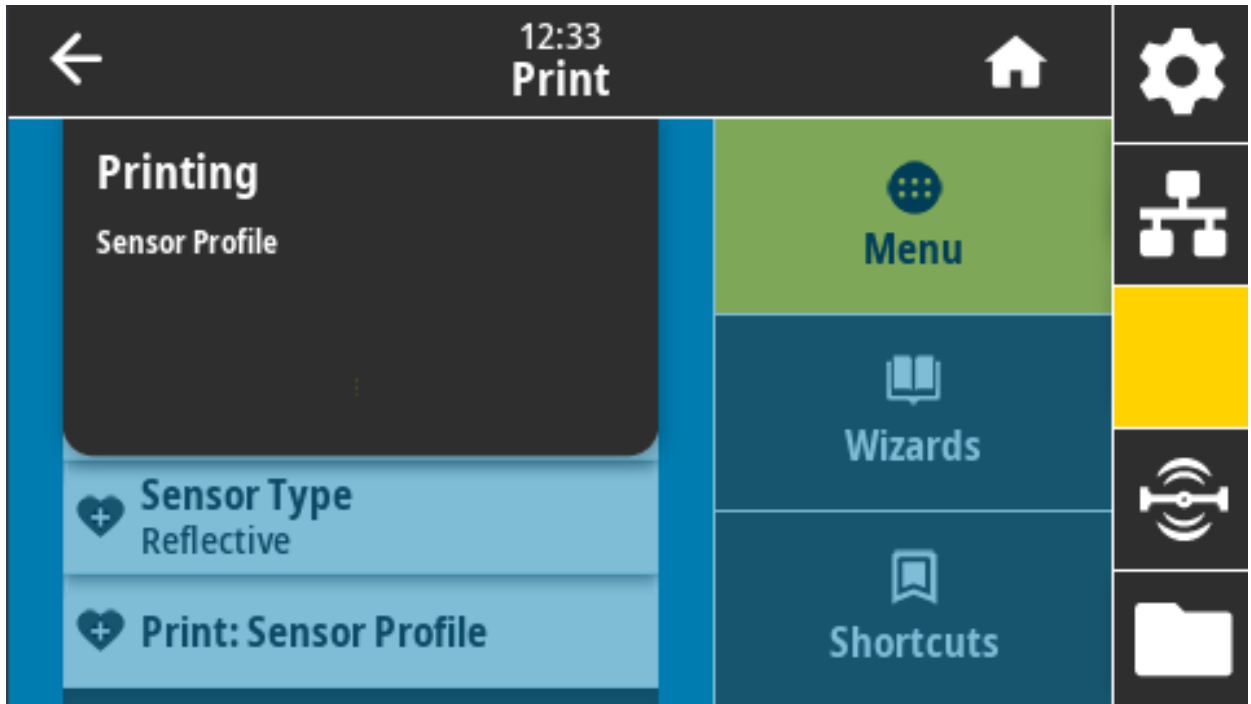

Transmissive (sees-through media and liner) - Used for gap/web sensing for the basic label and—continuous media

Reflective - Used for the detection of black marks/lines and notches/holes on the backside of media. Black markings and holes do not reflect.

Related ZPL command(s): ~JG

Control panel key(s): Hold **FEED** + **CANCEL** during printer power-up.

Printer web page: View and Modify Printer Settings > Print Listings on Label

Print > Print Station

Use this menu item to fill in variable fields in a label format and print the label using a Human Input Device (HID), such as a USB keyboard, scale, or barcode scanner.

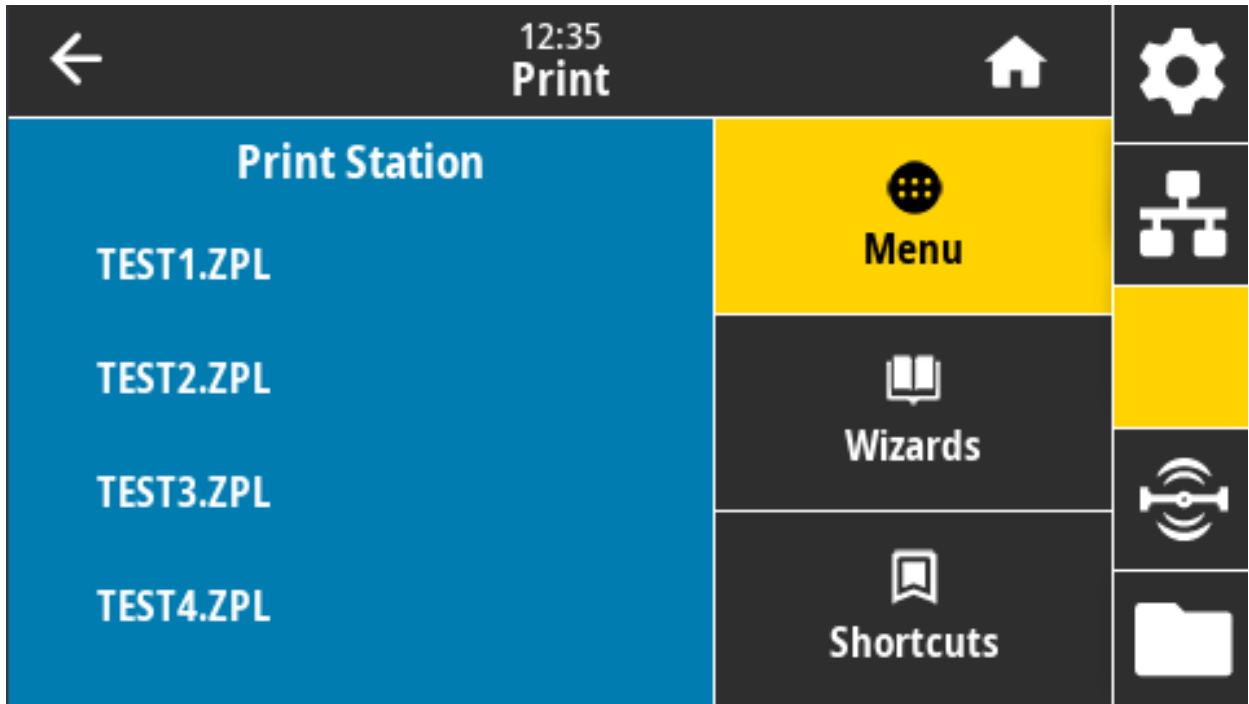

IMPORTANT: A suitable label format must be stored on the E: drive of the printer to use this option. Refer to the exercises in [Using the USB Hosts Port and the NFC Capabilities on page 237](#) for an exercise using this capability.

When you plug an HID into one of the printer's USB host ports, use this user menu to select a form on the printer's E: drive. After you have been prompted to fill in each variable ^FN field on the form, you can specify the desired quantity of labels to print.

For more information about using the ^FN command or the SGD commands related to this feature, refer to the Zebra Programming Guide at zebra.com/manuals for more information.

SGD command used:

```
usb.host.keyboard_input (must be set to ON)
usb.host.template_list
usb.host.fn_field_list
usb.host.fn_field_data
usb.host.fn_last_field
usb.host.template_print_amount
```

Print > Applicator > Applicator Port Mode

Controls the way in which the applicator port's "End Print" signal functions.

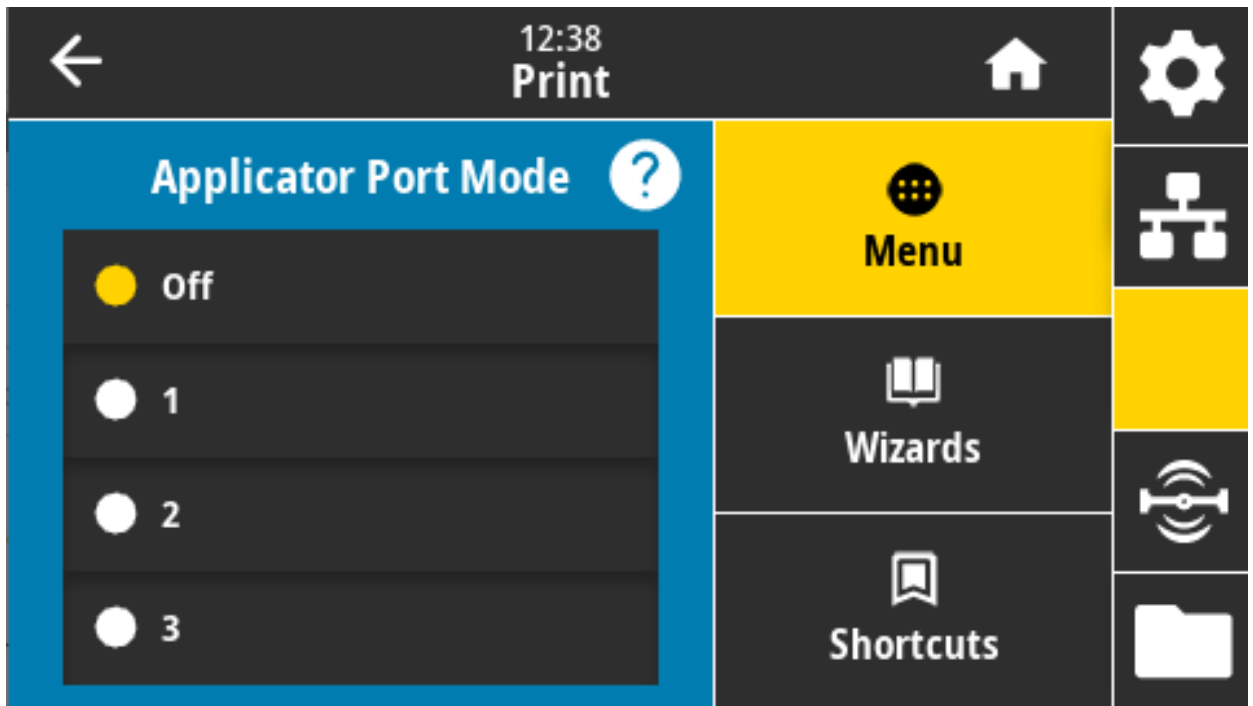

Accepted values:

Off

1 = End Print signal normally high, and low only when the printer is moving the label forward.

2 = End Print signal normally low, and high only when the printer is moving the label forward.

3 = End Print signal normally high, and low for 20 ms when a label has been printed and positioned.

4 = End Print signal normally low, and high for 20 ms when a label has been printed and positioned.

Related ZPL command(s): ^JJ

SGD command used: device.applicator.end_print

Print > Applicator > Start Print Mode

Determines if the applicator port's "Start Print" signal is in level mode or pulse mode.

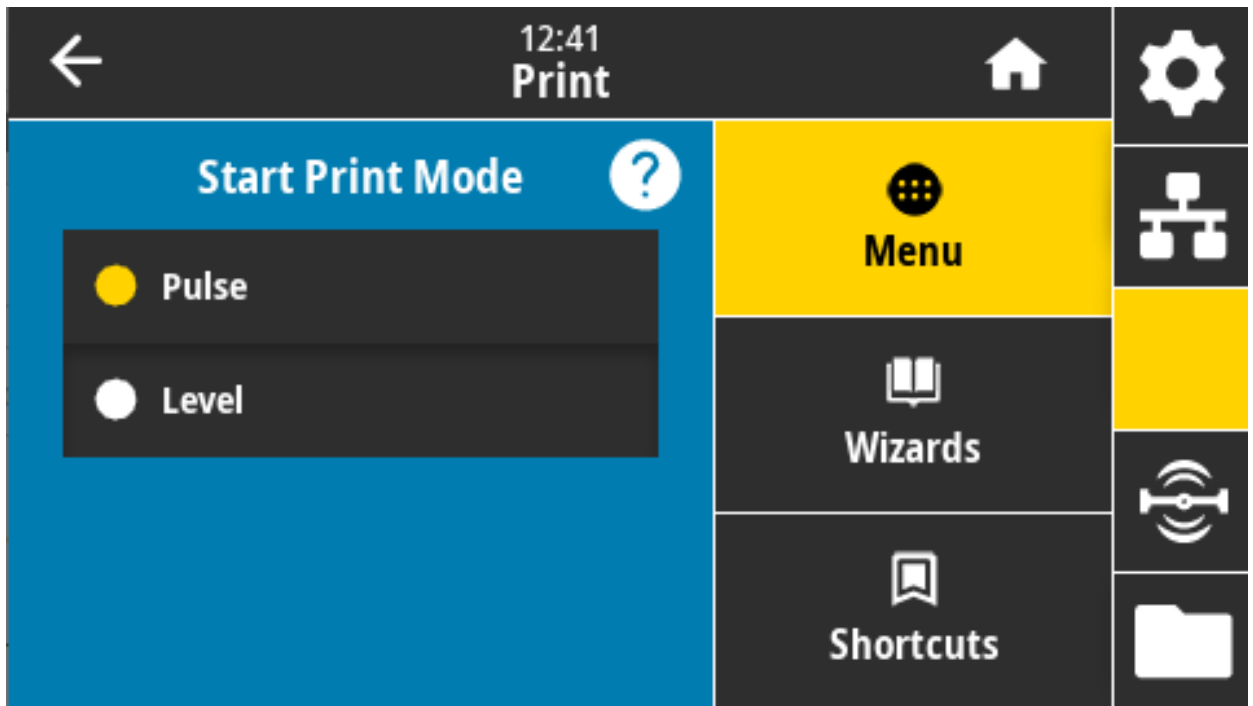

Accepted values:

Pulse—Start Print signal must be disabled before it can be asserted for the next label.

Level—Start Print signal does not need to be disabled to print the next label. As long as the Start Print signal is low and a label is formatted correctly a label prints.

Related ZPL command(s): ^JJ

SGD command used: device.applicator.start_print

Print > Applicator > Error on Pause

Determines how applicator port errors are treated by the printer. Enabling this feature also causes the "Service Required" pin to be asserted.

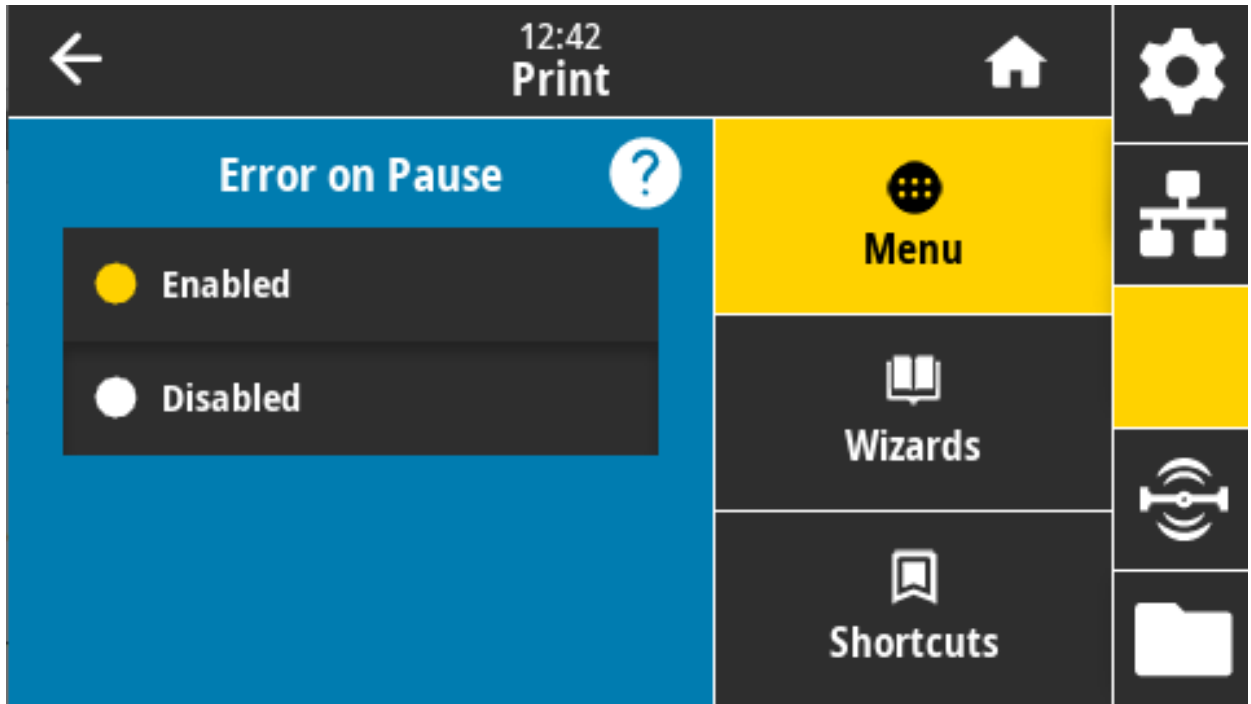

Accepted values: ENABLED, DISABLED

SGD command used: `device.applicator.error_on_pause`

Printer web page: View and Modify Printer Settings > Advanced Setup > Error on Pause

Print > Applicator > Applicator Reprint

Specifies if a high or low value is required for an applicator to reprint a label.

Enables or disables the ~PR command, which when enabled reprints the last printed label. It also enables the Reprint button on the Home screen.

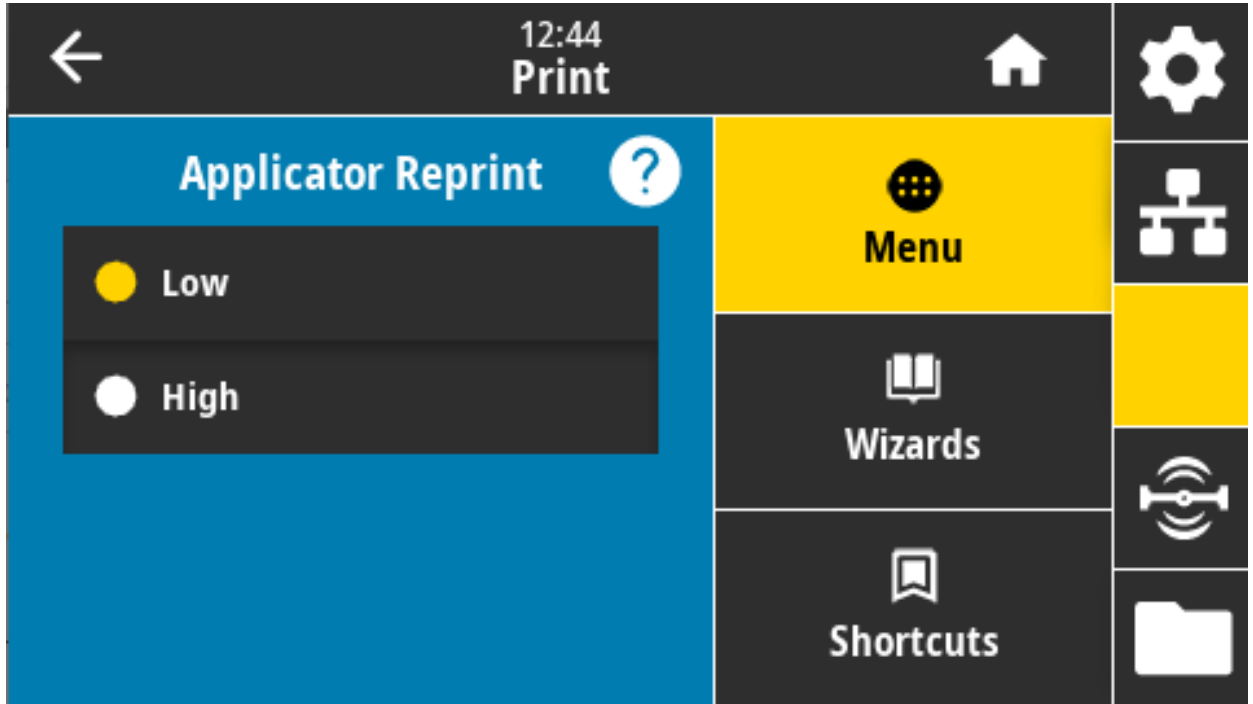

Related ZPL command(s): ^JJ, ~PR

SGD command used: device.applicator.reprint

RFID Menu

Use this menu to configure, monitor, and test the RFID subsystem operation.

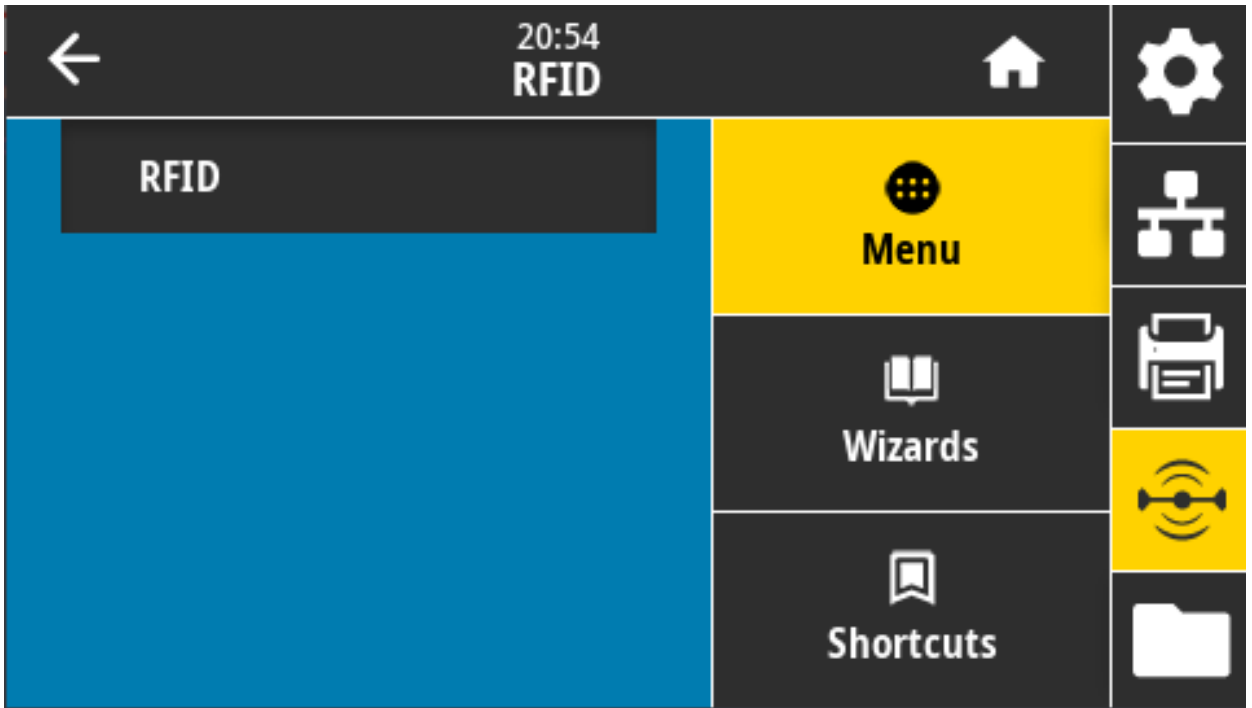

RFID > RFID Status

Display the status of the RFID subsystem of the printer.

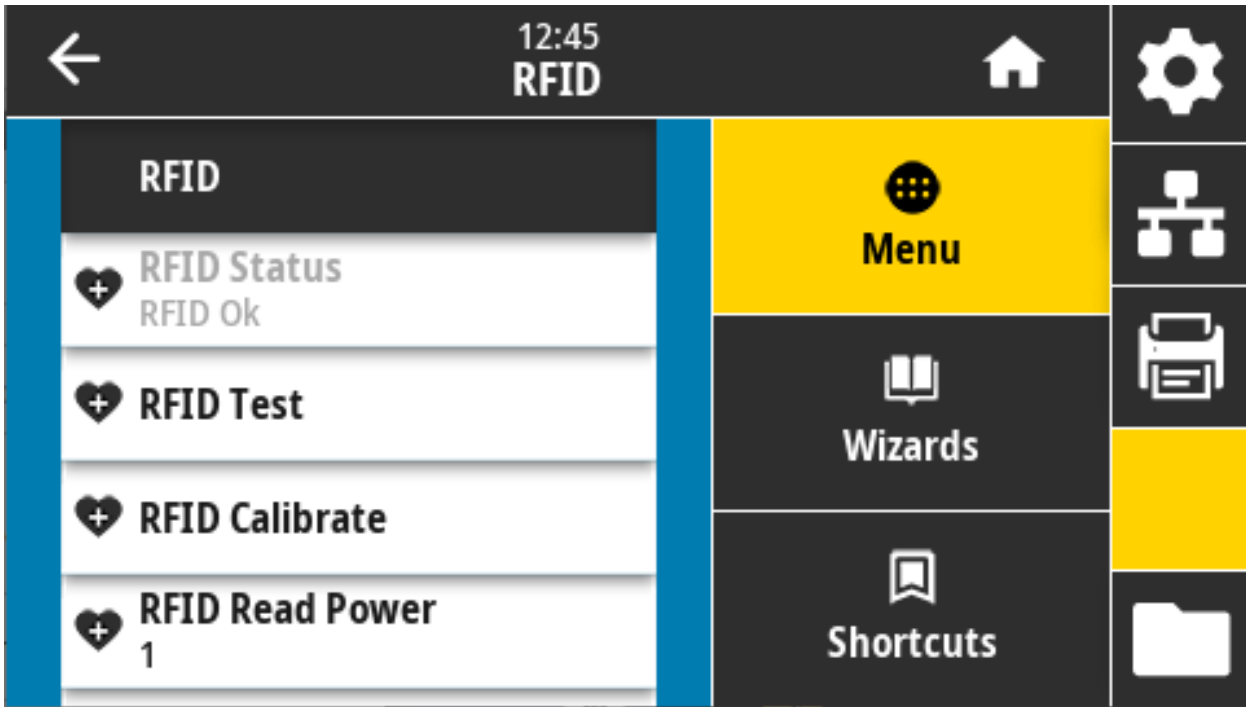

Related ZPL command(s): ^HL, ~HL

SGD command used: rfid.error.response

RFID > RFID Test

During the RFID test, the printer attempts to read and write to a transponder. No printer movement occurs with this test.

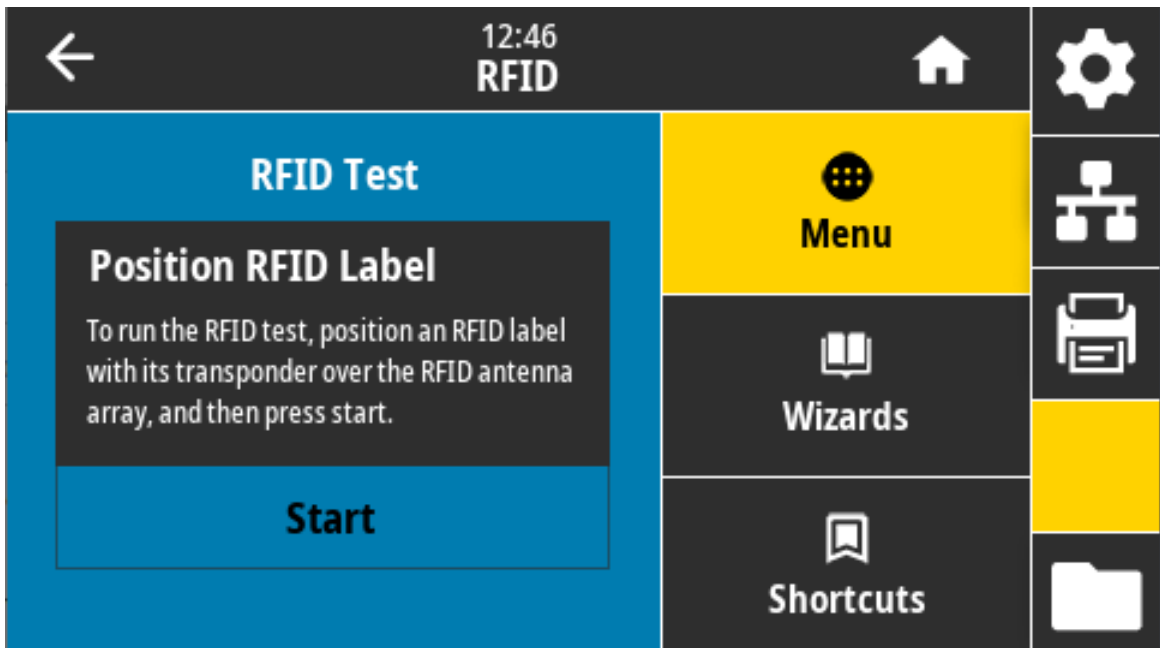

To test an RFID label:

- a. Position the RFID label with its transponder over the RFID antenna array.
- b. Touch Start.

The typical results are shown on the display.

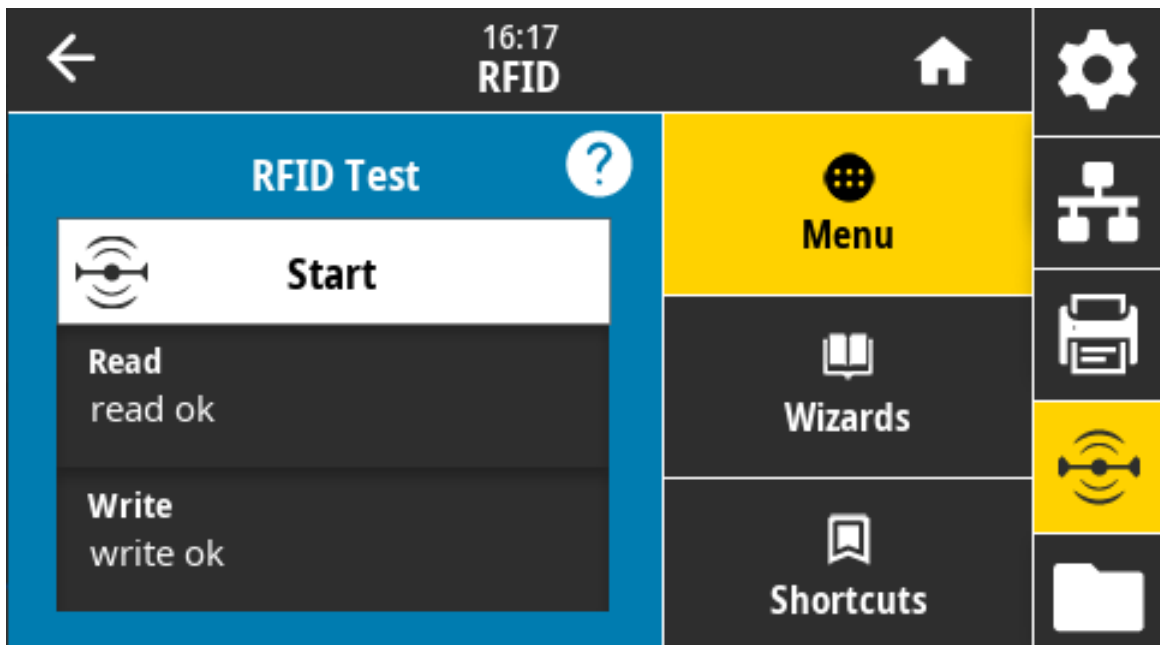

SGD command used: `rfid.tag.test.content` , `fid.tag.test.execute`

RFID > RFID Calibrate

Initiate tag calibration for RFID media. (Not the same as media and ribbon calibration.) During the process, the printer moves the media, calibrates the RFID tag position, and determines the optimal settings for the RFID media being used. These settings include the programming position, the antenna element to use, and the read/write power level to use. Refer to the RFID Programming Guide 3 for more information.



NOTE: Before running this command, load the printer with RFID media, calibrate your printer, close the printhead, and feed at least one label to make sure that tag calibration will begin from the correct position.

Leave all transponders before and after the tag that is being calibrated. This allows the printer to determine RFID settings which do not encode the adjacent tag. Allow a portion of media to extend out the front of the printer to allow for backfeed during the tag calibration procedure.

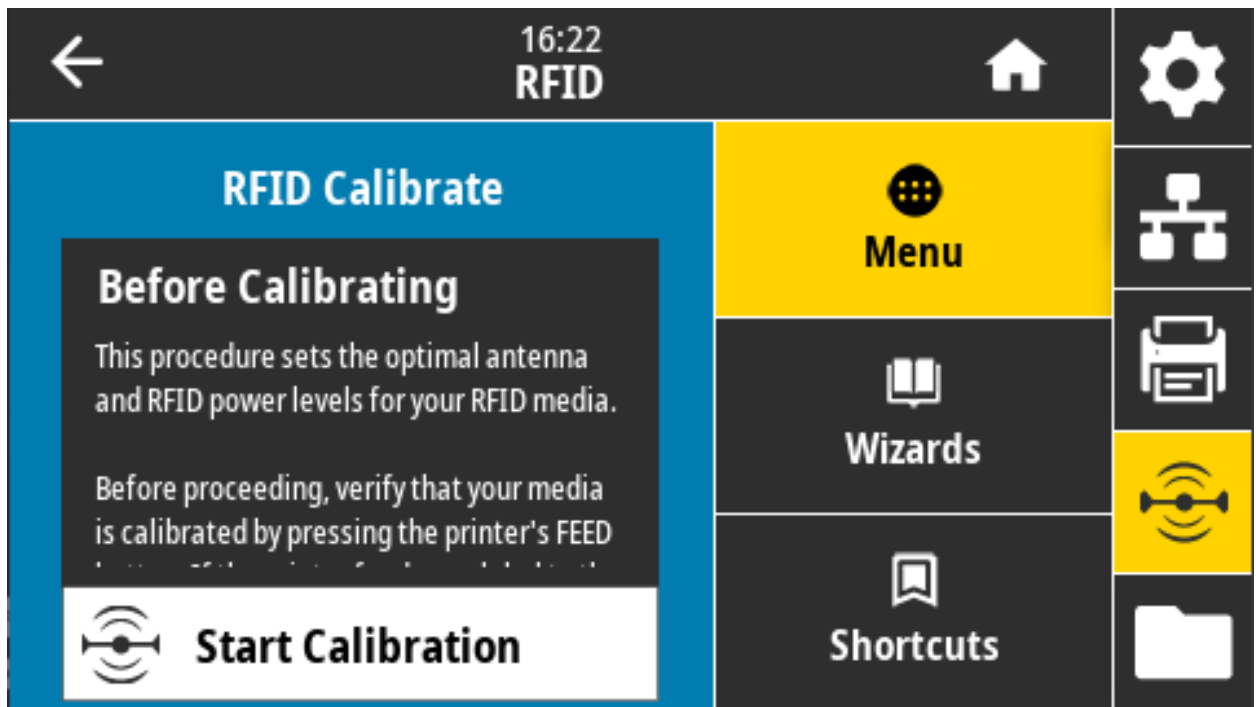

Related ZPL command(s): ^HR

SGD command used: rfid.tag.calibrate

RFID > Read Power

If the desired read power is not achieved through RFID tag calibration, a value may be specified.

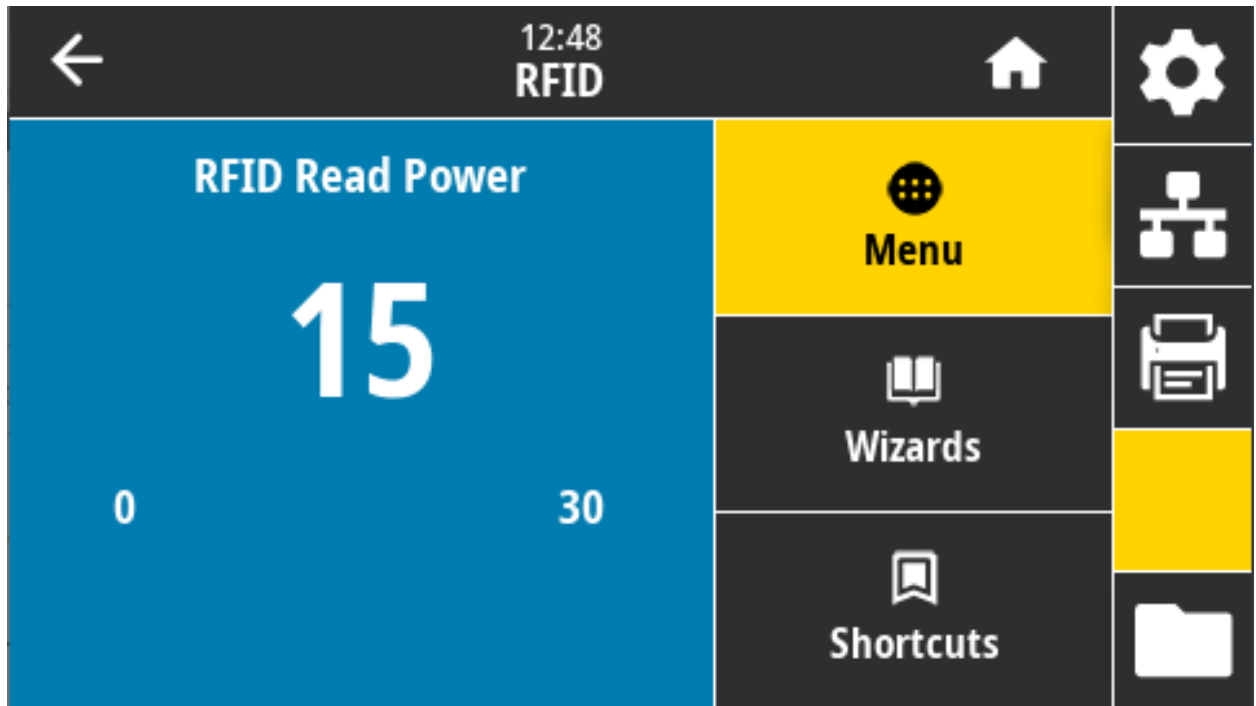

Accepted values: 0 to 30

Related ZPL command(s): ^RW

SGD command used: rfid.reader_1.power.read

Printer web page: View and Modify Printer Settings > RFID Setup > RFID READ PWR

RFID > Write Power

If the desired write power is not achieved through RFID tag calibration, a value may be specified.

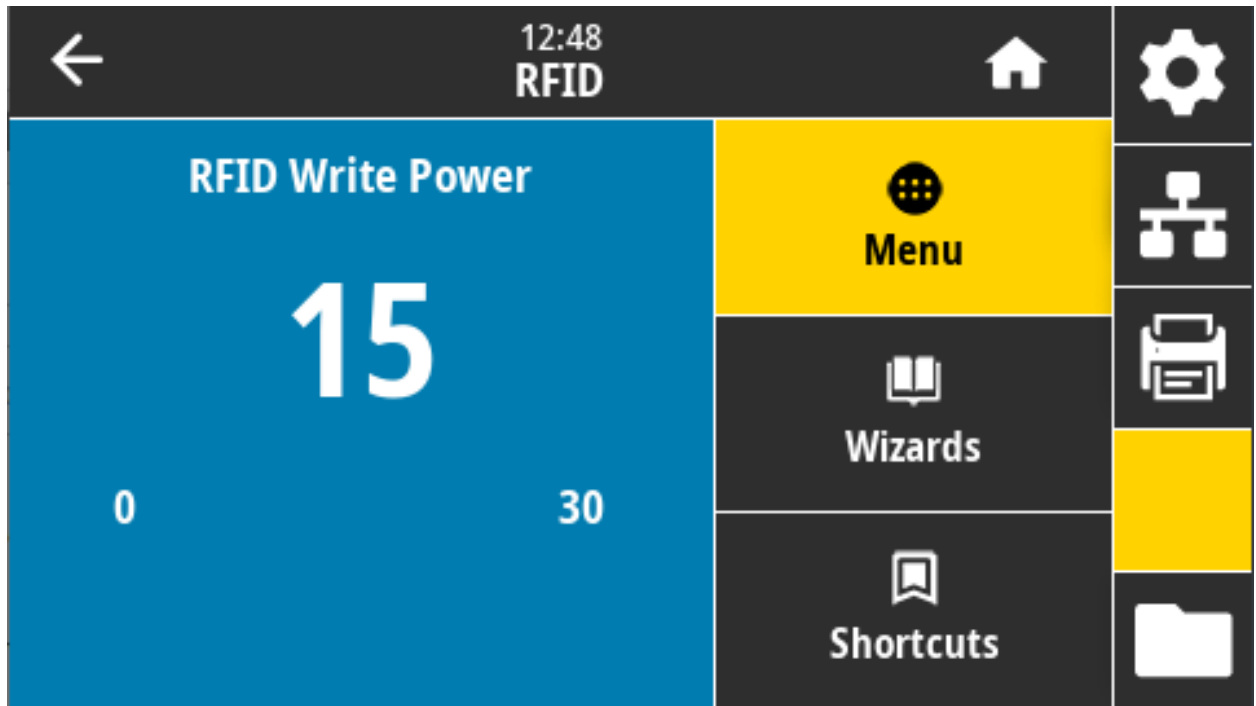

Accepted values: 0 to 30

Related ZPL command(s): ^RW

SGD command used: rfid.reader_1.power.write

Printer web page: View and Modify Printer Settings > RFID Setup > RFID WRITE PWR

RFID > RFID Antenna

If the desired antenna selection is not achieved through RFID tag calibration, a value may be specified.

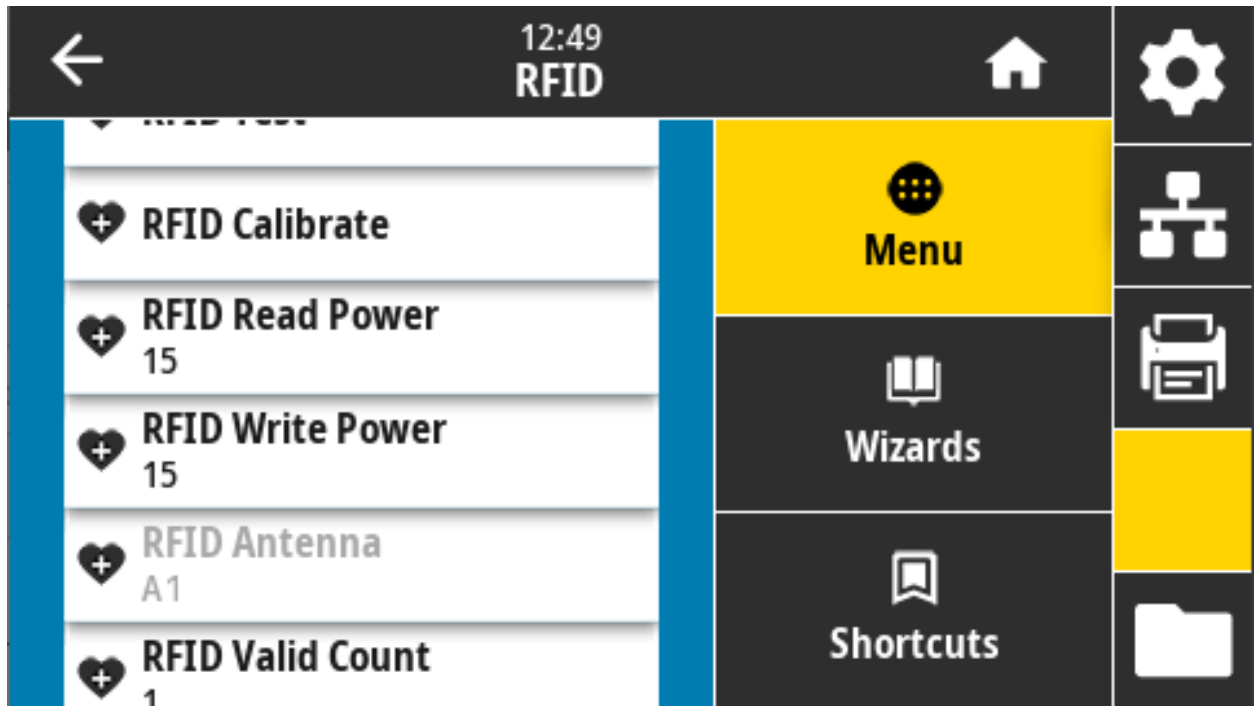

Accepted values: A1 default and only valid setting (for center aligned antennas used in this Zebra printer).

Related ZPL command(s): ^RW

SGD command used: rfid.reader_1.antenna_port

Printer web page: View and Modify Printer Settings > RFID Setup > RFID ANTENNA

RFID > RFID Valid Count

Resets the RFID valid label counter to zero.

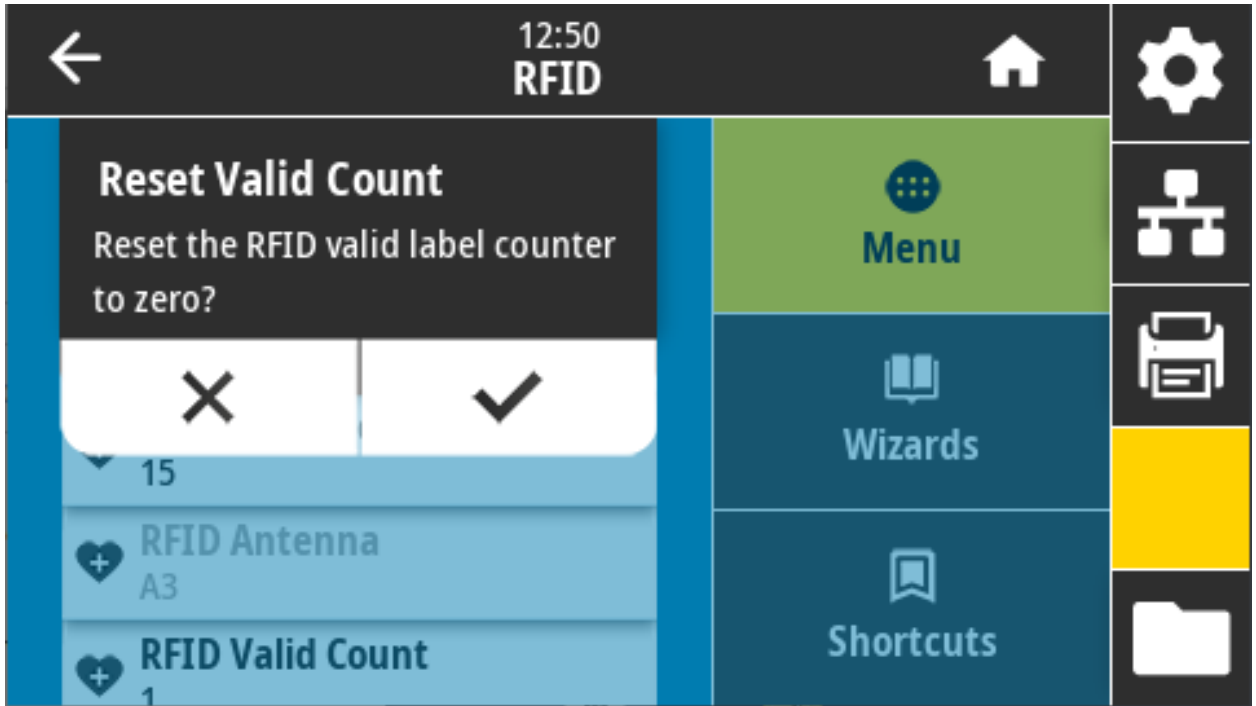

Related ZPL command(s): ~R0

SGD command used: `odometer.rfid.valid_resettable`

RFID > RFID Void Count

Resets the RFID void label counter to zero.

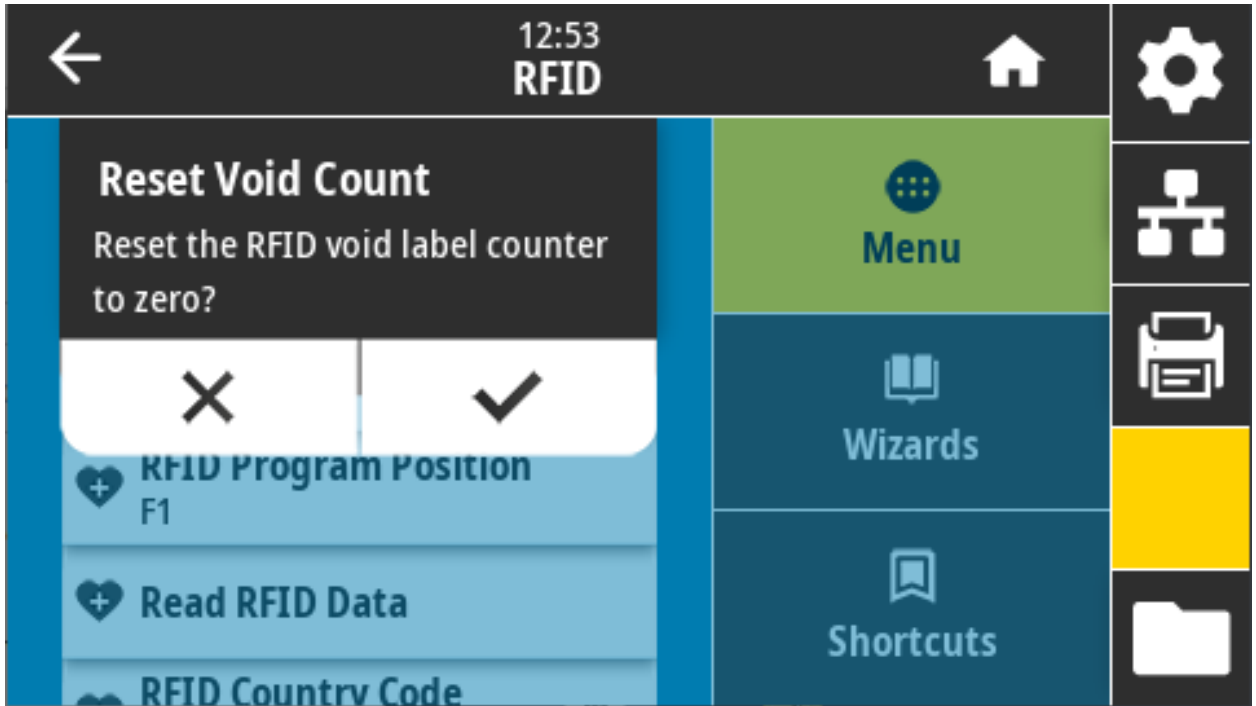

Related ZPL command(s): ~R0

SGD command used: `odometer.rfid.void_resettable`

RFID > RFID Program Position

If the desired programming position (read/write position) is not achieved through RFID tag calibration, a value may be specified.

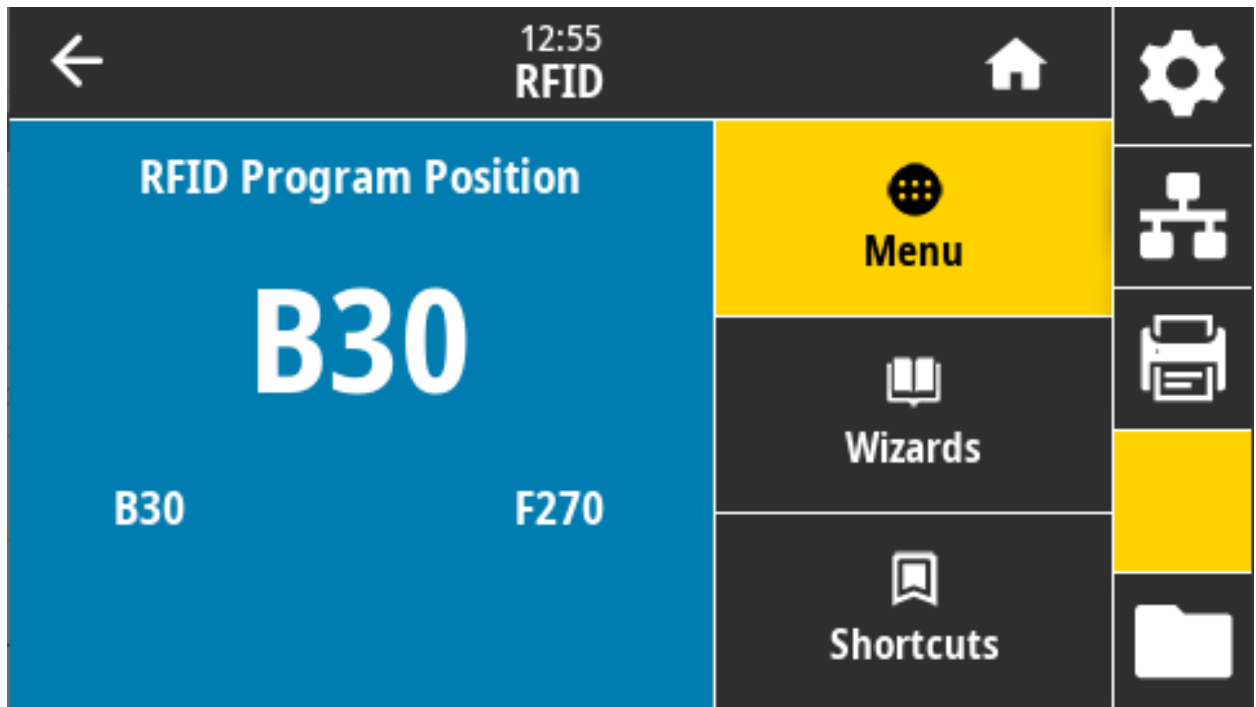

Accepted values:

F0 to Fxxx (where xxx is the label length in millimeters or 999, whichever is less) — The printer feeds the label forward for the specified distance and then begins programming.

B0 to B30 — The printer backfeeds the label for the specified distance and then begins programming. To account for the backfeed, allow the empty media liner to extend out of the front of the printer when using a backward programming position.

Related ZPL command(s): ^RS

SGD command used: rfid.position.program

Printer web page: View and Modify Printer Settings > RFID Setup > PROGRAM POSITION

RFID > Read RFID Data

Read and return the specified tag data from the RFID tag located over the RFID antenna. No printer movement occurs while tag data is being read. The printhead can be open or closed.

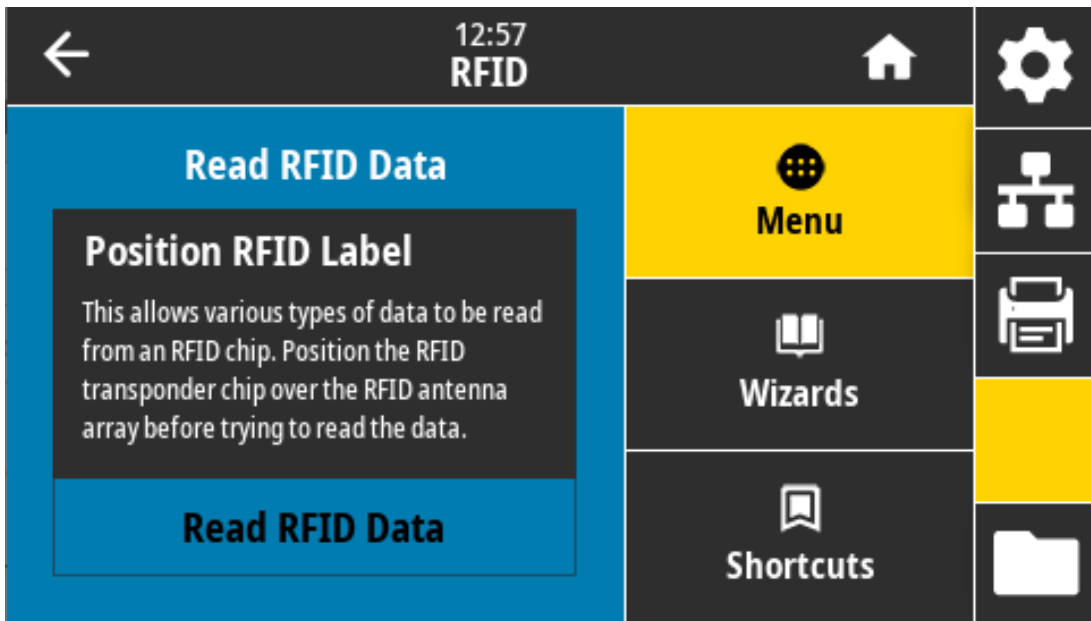

To read and display the information stored on an RFID tag:

- a. Position the RFID label with its transponder over the RFID antenna.
- b. Touch Read RFID Data.

The results of the test are shown on the display.

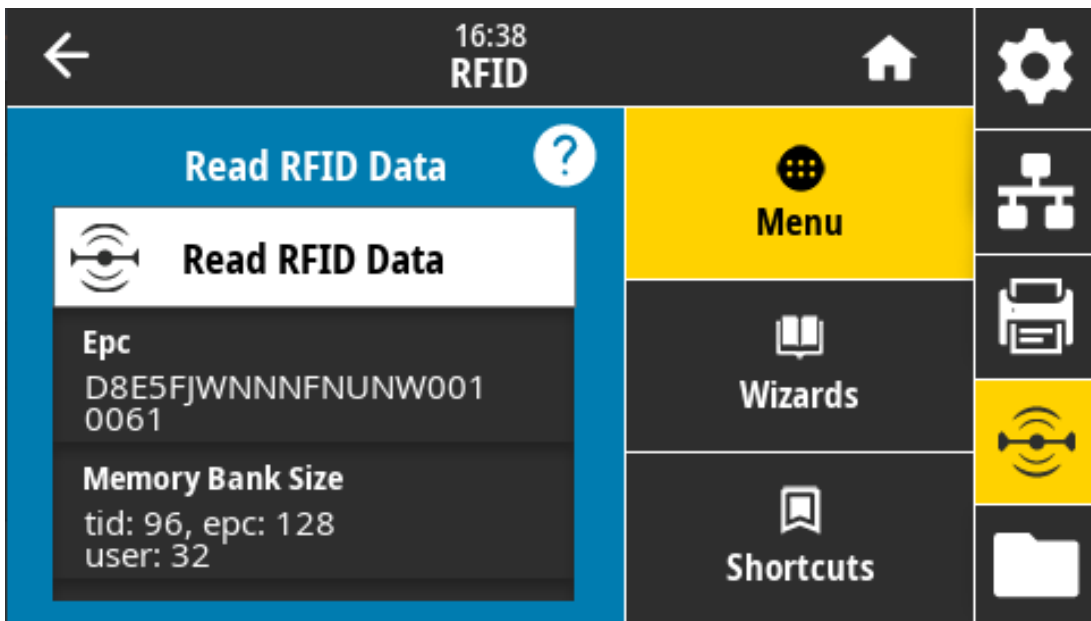

Related ZPL command(s): ^RF

SGD command used: rfid.tag.read.content, rfid.tag.read.execute

Storage Menu

Use this menu to manage file operations within the printer, accessing external files via the USB Host, and print label formats.

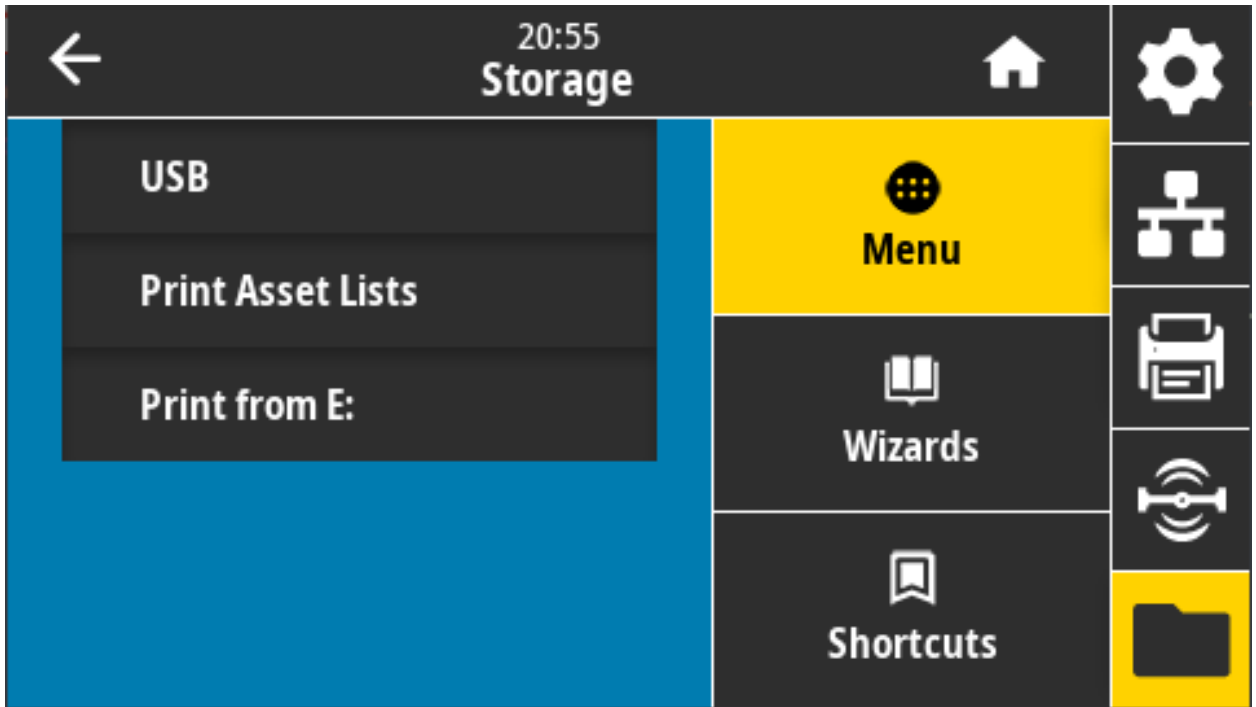

Storage > USB > Copy: Files to USB

Select files from the printer to store on a USB Flash drive.

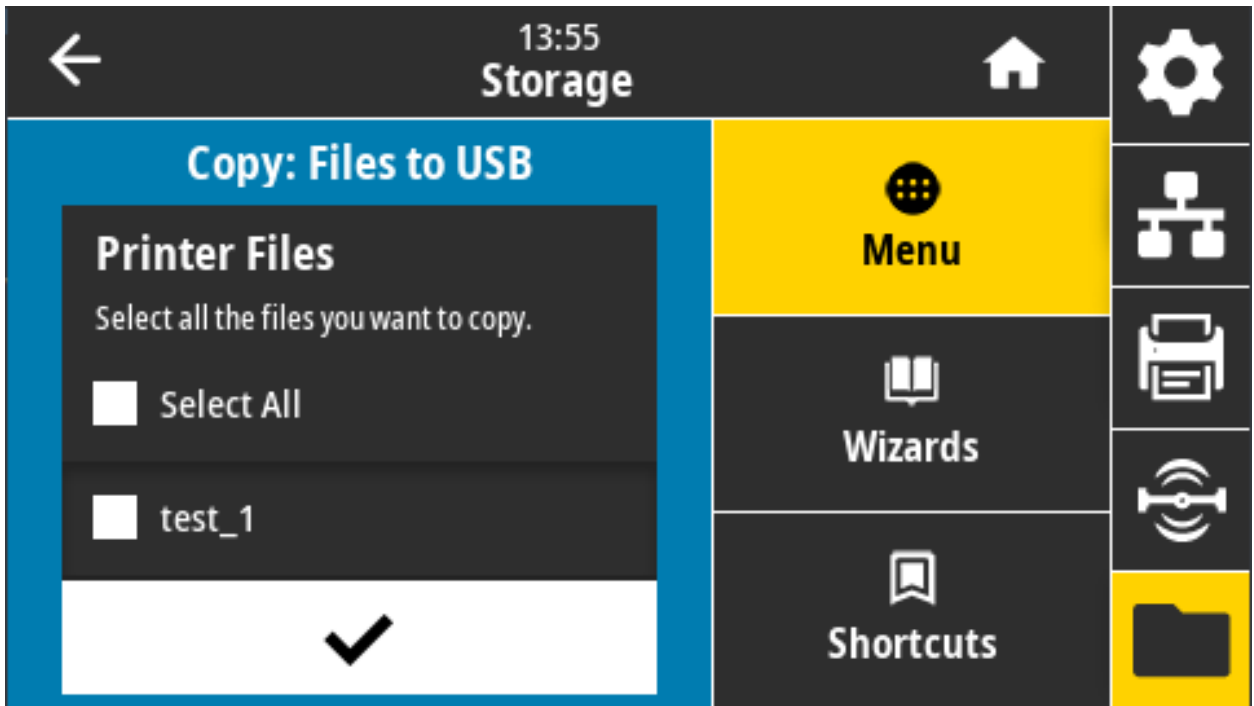

To copy files from the printer to a USB Flash drive:

- a. Insert a USB flash drive into the printer's USB host port.

The printer lists available files.

- a. Touch the box next to the desired files. Select All is also available.
- b. Touch the checkmark to copy the selected files.

SGD command used: `usb.host.write_list`

Storage > USB > Copy: Files to Printer

Select files to copy to the printer from a USB Flash drive.

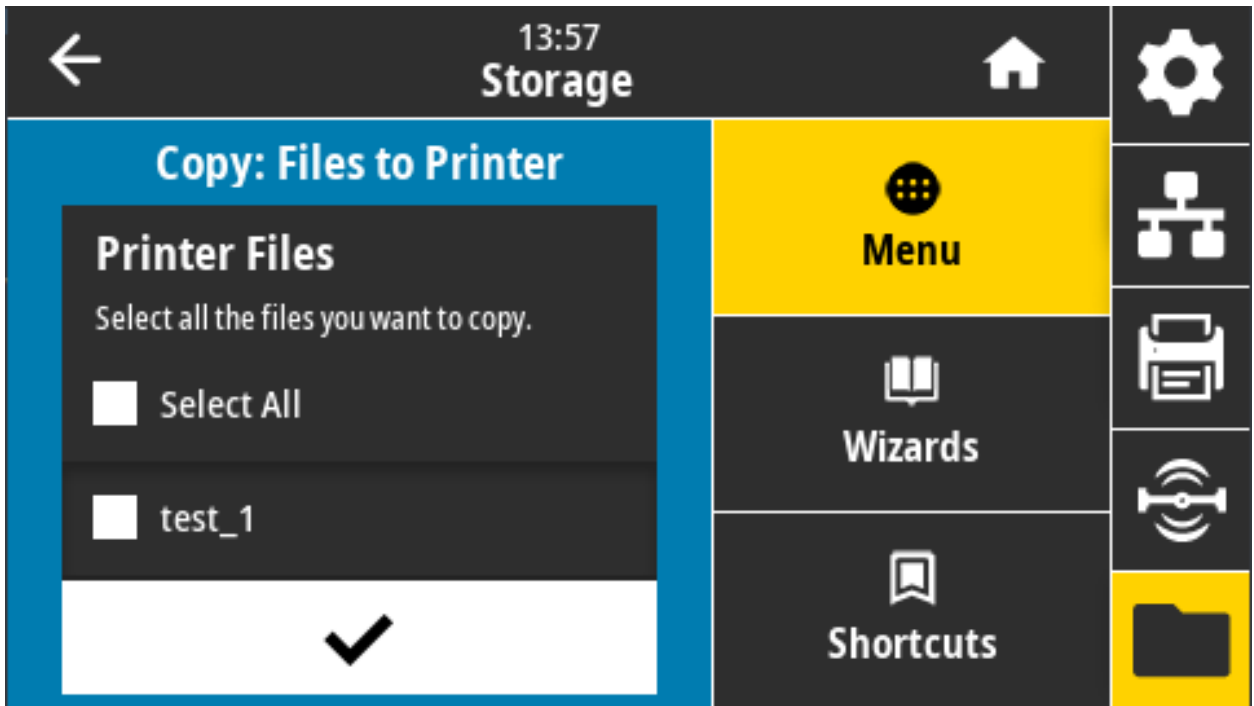

To copy files to the printer from a USB Flash drive:

- a. Insert a USB flash drive into the printer's USB host port.

The printer lists available files.

- a. Touch the box next to the desired files. Select All is also available.
- b. Touch the checkmark to copy the selected files.

SGD command used: `usb.host.read_list`

Storage > USB > Copy: Configuration to USB

Use this function to copy the printer's configuration information to a USB mass storage device, such as a USB Flash drive, that is plugged into one of the printer's USB host ports. This makes the information accessible without having to print physical labels.

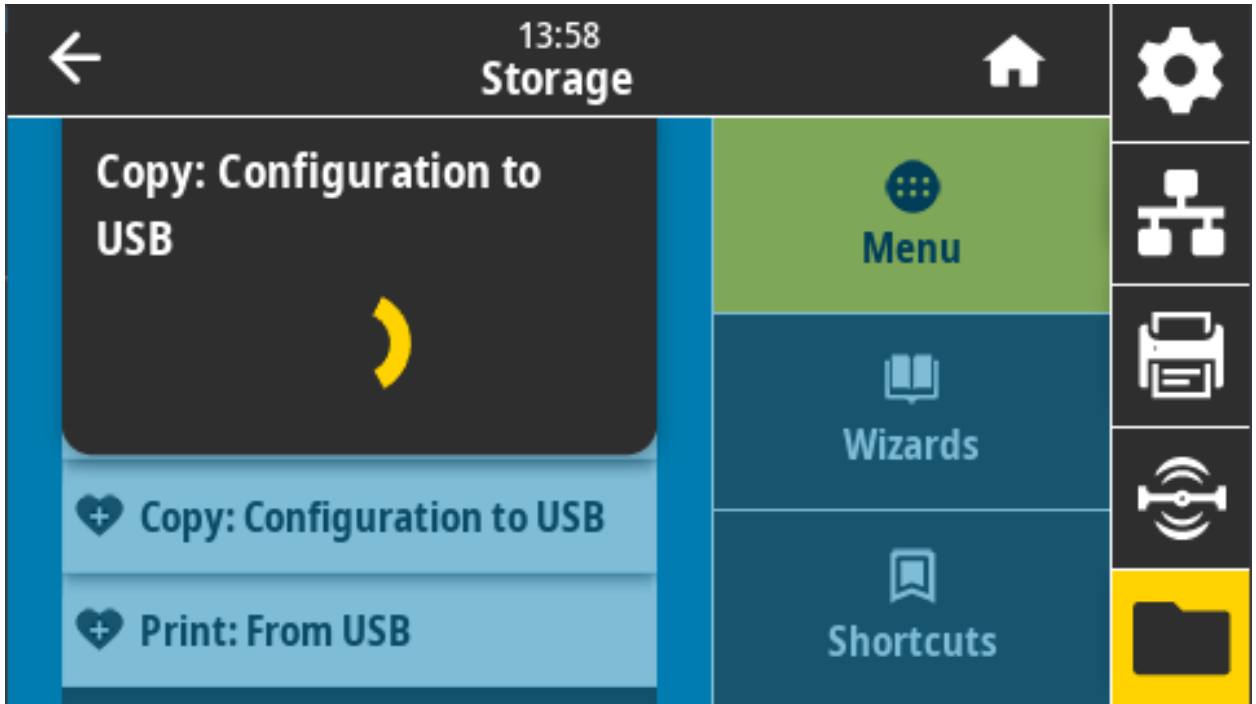

Related ZPL command(s):

^HH — Returns the printer configuration information returned to the host computer.

Printer web page:

Printer Home Page > View Printer Configuration (to view printer configuration information on your web browser)

View and Modify Printer Settings > Print Listings on Label (to print the configuration information on labels)

Storage > USB > Print: From USB

Select files to print from a USB Flash drive.

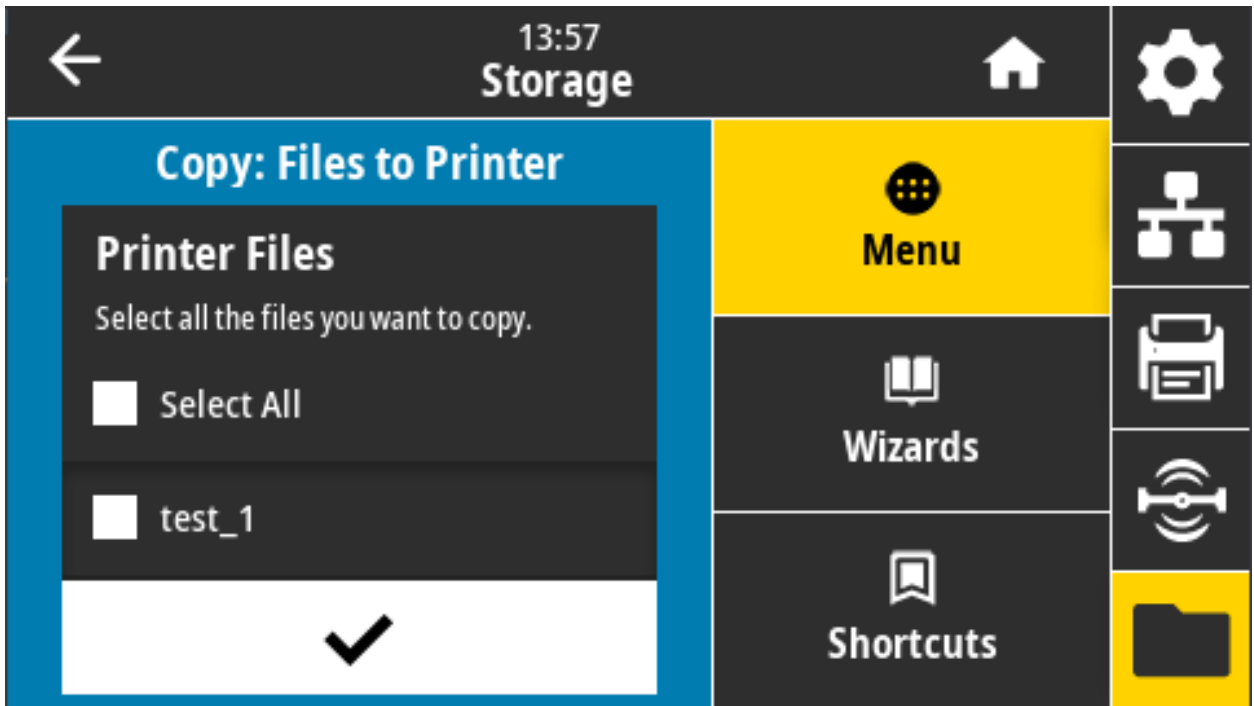

To print files from a USB Flash drive:

- a. Insert a USB flash drive into the printer's USB host port.

The printer lists available files.

- a. Touch the box next to the desired files. Select All is also available.
- b. Touch the checkmark to print the selected files.

SGD command used: `usb.host.read_list`

Storage > Print Asset Lists

Print the specified information on one or more labels.

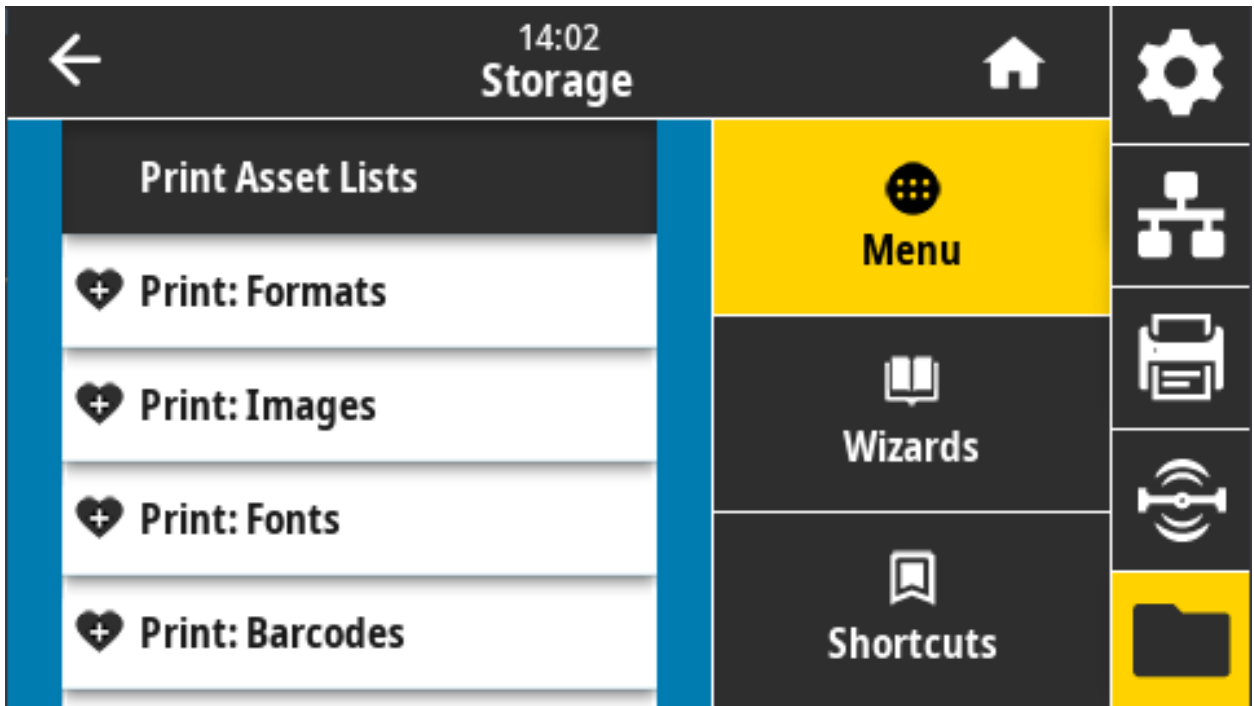

Accepted values:

Formats — Prints the available formats stored in the printer's RAM, Flash memory, or optional memory card.

Images — Prints the available images stored in the printer's RAM, Flash memory, or optional memory card.

Fonts — Prints the available fonts in the printer, including standard printer fonts plus any optional fonts. Fonts may be stored in RAM or Flash memory.

Barcodes — Prints the available barcodes in the printer. Barcodes may be stored in RAM or Flash memory.

All—Prints the previous labels plus the printer configuration label and the network configuration label.

Related ZPL command(s): ^WD

Printer web page: View and Modify Printer Settings > Print Listings on Label

Storage > USB > Print from E:

Select files to print from files in printer E: memory.

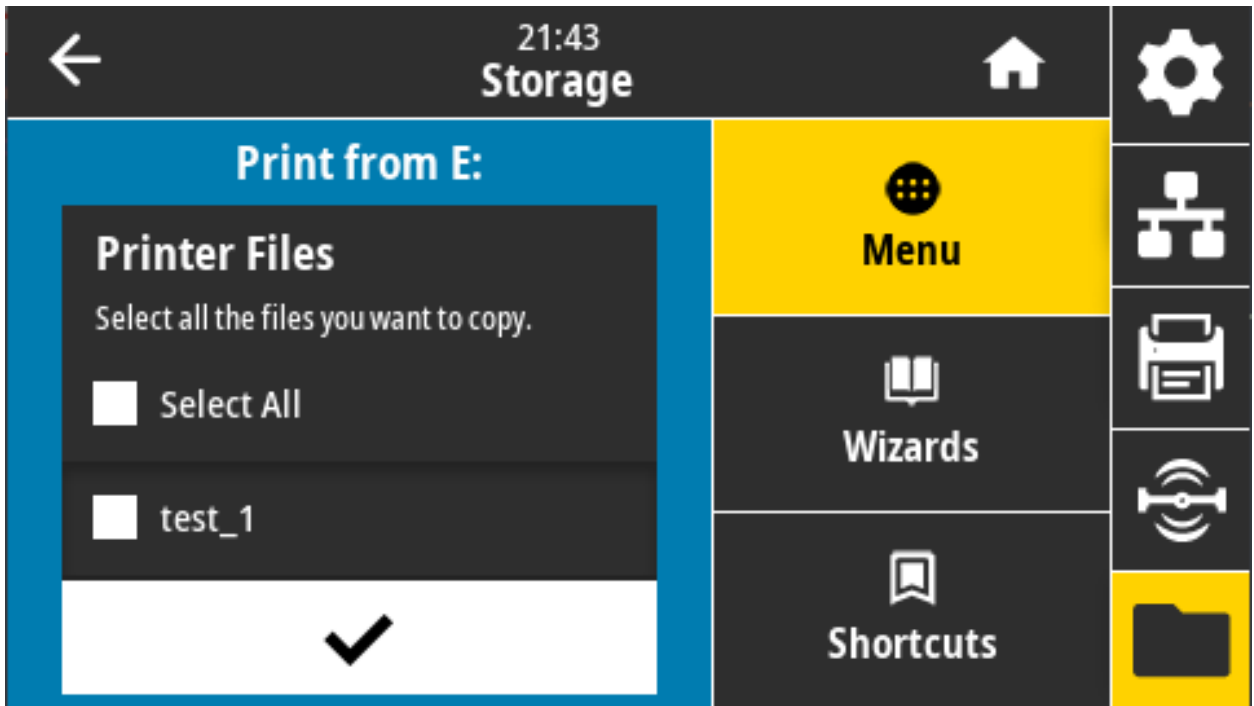

To print files from printer E: memory:

The printer lists available files.

- a. Touch the box next to the desired files. Select All is also available.
- b. Touch the checkmark to print the selected files.

SGD command used: `usb.host.write_list`

Setup

This section assists you in setting up and operating your printer. The setup process can be broken down into two (2) phases: hardware setup and host system (software/driver) setup. This section covers the physical hardware setup needed to print your first label.

Printer Setup Overview

Below is an overview of the procedures necessary for setting up your printer.

1. Install any printer hardware options first. Go to [Install Hardware Options on page 47](#).
2. Place the printer in a safe location with access to power and where you can connect interface cables or wirelessly to the system.
3. Attach the printer and power supply to a grounded AC power source.
4. Select and prepare media for your printer.
5. Load the media.
6. Turn the printer ON. Calibrate the media with a SmartCal Media calibration.
7. Print a Configuration Report to verify basic printer operation.
8. Turn the printer OFF.
9. Choose a method to communicate via a wired or wireless connection to your printer. Available wired local connections are:
 - USB port
 - Optional Serial port
 - Optional Ethernet (LAN)
10. Attach the printer cable to the network or host system (printer OFF).
11. Begin the second phase of printer setup: typically [Setup for Windows® OS on page 186](#).

Select a Location for the Printer

The printer and media need a clean safe area with moderate temperatures to have optimal print operations.

Select a location for the printer that meets these conditions:

- **Surface:** The surface where the printer will be located must be solid, level, and of sufficient size and strength to hold the printer with media.

- **Space:** The area where the printer will be located must include enough space for opening the printer (media access and cleaning), and for printer access to connectivity and power cords. To allow for proper ventilation and cooling, leave open space on all sides of the printer.



IMPORTANT: Do not place any padding or cushioning material under or around the base of the printer because this restricts air flow and could cause the printer to overheat.

- **Power:** Put the printer close to an easily accessible power outlet.
- **Data Communication Interfaces:** Please ensure that cabling and Wi-Fi or Bluetooth radios do not exceed the maximum distance specified by the communication protocol standard or product data sheet for this printer. Radio signal strength can be reduced by physical barriers (objects, walls, etc.).
- **Data Cables:** Cables should not be routed with or near power cords or conduits, fluorescent lighting, transformers, microwave ovens, motors or other sources of electrical noise and interference. These interference sources may cause problems with communications, host system operation, and printer functionality.
- **Operating Conditions:** Your printer is designed to function in a wide range of environments.
 - **Operational Temperature:** 32° to 104°F (0° to 40°C)
 - **Operational Humidity:** 20 to 85% non-condensing
 - **Non-Operational Temperature:** -40° to 140°F (-40° to 60°C)
 - **Non-Operational Humidity:** 5 to 85% non-condensing

Install Printer Options and Connectivity Modules

Install the following printer options before proceeding with the printer's setup.

- Wireless (802.11ac and Bluetooth 4.2) Module - [Installing the Wireless Connectivity Module on page 53](#)
- Serial (RS-232 DB-9) Port Module - [Installing the Serial Port Module on page 50](#)
- Internal Ethernet (LAN) Module - [Installing the Internal Ethernet \(LAN\) Module on page 51](#)
- Label Dispenser (Peel-Off Liner and Present Label for Operator) - [Installing the Label Dispenser on page 57](#)
- Linerless media cutter - [Installing the Standard Media Cutter on page 58](#)
- Linerless Media Tear-Off bezel- [Installing the Label Dispenser on page 57](#)
- General purpose media cutter - [Installing the Standard Media Cutter on page 58](#)
- [Media Roll Core Size Adapters on page 61](#) for 38.1 mm (1.5 in.), 50.8 mm (2.0 in.), or 76.2 (3.0 in.) I.D. media cores.
- [Print Resolution Upgrade Kits on page 63](#) (200 and 300 dpi for standard and Linerless media)

Attaching Power



CAUTION: Never operate the printer and power supply in an area where they can get wet. Serious personal injury could result!



NOTE: Set up your printer so that you can handle the power cord easily if needed. Some processes for setup or troubleshooting issues may ask you to remove power. Separate the power cord from the power supply receptacle or AC electrical outlet to make certain the printer cannot carry electrical current.

1. Plug the power supply into the printer's DC power receptacle.
2. Insert the AC power cord into the power supply.
3. Plug the other end of the AC power cord into an appropriate AC electrical outlet. Note that AC outlet end of the power cord's plug type can vary by region.
4. The active power light will turn on green if power is on at the AC outlet.



IMPORTANT: Ensure the appropriate power cord with a three (3) prong plug and an IEC 60320-C13 connector are used at all times. These power cords must bear the relevant certification mark of the country in which the product is being used.

Getting Ready to Print

The printer setup cannot be completed without media. The media may be labels, tags, tickets, receipt paper, fan-fold stacks, tamper proof labels, etc. Ideally choose the same media used for normal operation. This will help you identify any setup and real application issues while using this guide. The printer does not come with media.

The Zebra Web site or your reseller may be able to help you select the right media for your intended printing application. Find media at: zebra.com/supplies.

Preparing and Handling Media

Careful handing and storage of your media is important in order to maximize print quality. If the media becomes contaminated or dirty, it can damage the printer and cause defects in the printed image (voids, streaks, discoloration, compromise the adhesive, etc.).



IMPORTANT: During manufacturing, packaging, handling and storage, the outside length of media may become dirty or contaminated. We recommend removing the outside layer of the media roll or stack. This will remove any contaminants which might be transferred onto the printhead during normal operation.

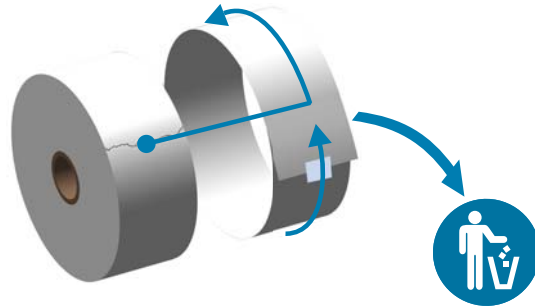

Media Storage Tips

- Store media in a clean, dry, cool, dark area. Direct thermal media is chemically treated to be heat sensitive. Direct sunlight or heat sources may 'expose' the media.
- Do not store media with chemicals or cleaning products.
- Leave media in its protective packaging until it is going to be put in the printer.
- Many media types and label adhesives have a 'shelf life' or expiration date. Always use the oldest, viable (non-expired) media first.

Loading Roll Media

All of the ZD621 and ZD421 4 inch Link-OS printers load print media rolls the same. The printers support the three basic types of media:

- **Continuous** (receipt, etc.) with no marks to define print length,
- **Marked media** (black lines, black marks, notches, or holes) to define print length
- **Label media** that uses the sensor to look through the media backing (liner) to see the beginning and end of labels on the roll.

The printer utilizes two (2) sensing methods to accommodate a wide range of media:

- Center area transmissive sensing for continuous media and gap/web label media.
- Full-width movable (reflective) sensing for print format (length) using black marks, black lines, notches or holes.

Setting Media Sensing by Media type

- For web/gap media, the printer senses the differences between the label and the liner to determine the print format length.
- For continuous roll media, the printer only senses the media's characteristics. The print format's length is set by programming (driver or software) or the last stored form's length.
- For black mark media, the printer senses the beginning of the mark and the distance to the start of the next black mark to measure the print format length.
- For other common media and setting variations, go to one of the following:
 - [Using the Label Dispenser Option on page 214](#) after you have loaded media using this procedure.
 - [Printing on Fan-Fold Media on page 210](#).

Instructions for media loading:

This procedure works for Tear-Off (standard bezel), Label Dispense and Media Cutting printer options.

1. Open the printer. Pull the release latch levers toward the front of the printer.



2. Open the media roll holders. Orient the media roll so that its printing surface will face up as it passes over the platen (drive) roller. Pull the media guides open with your free hand and place the media roll on the roll holders and release the guides. Verify the roll turns freely. The roll must not sit in the bottom of the media compartment.

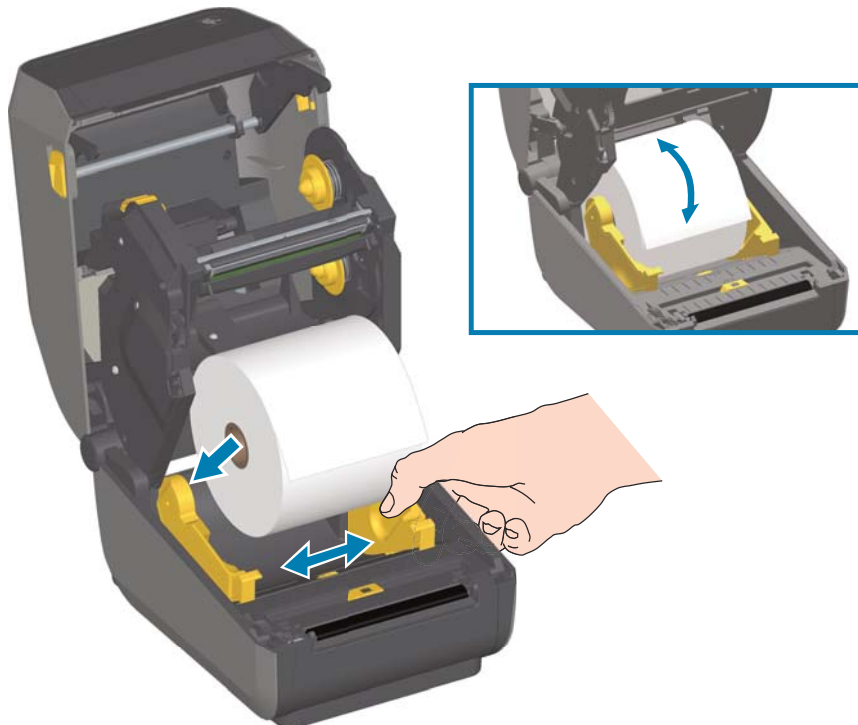

3. Pull the media so that it extends out of the front of the printer.

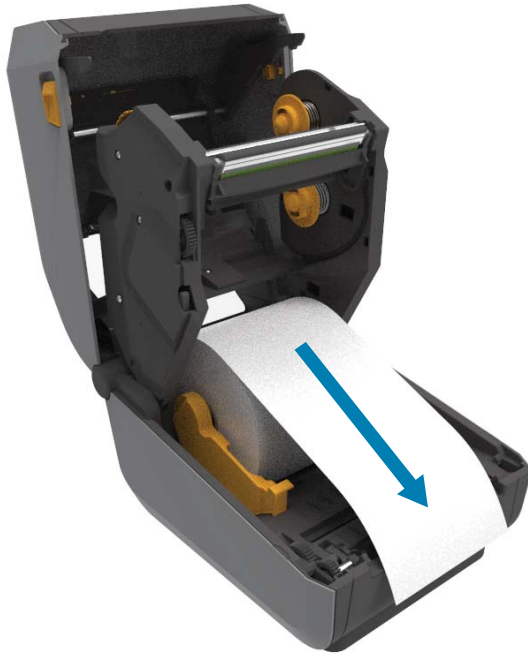

4. Push the media under both of the media guides.



5. Flip the media up and align the movable media sensor for your media type.
 - **For continuous roll receipt type media or label media** without black marks or notches, align the media to the default center position.
 - **For black mark (black line, notches or holes) backed media**, adjust the sensor position so the sensor aligns to the center of the black mark. Avoid the center area of the media to only use black mark sensing for operation with black marks.

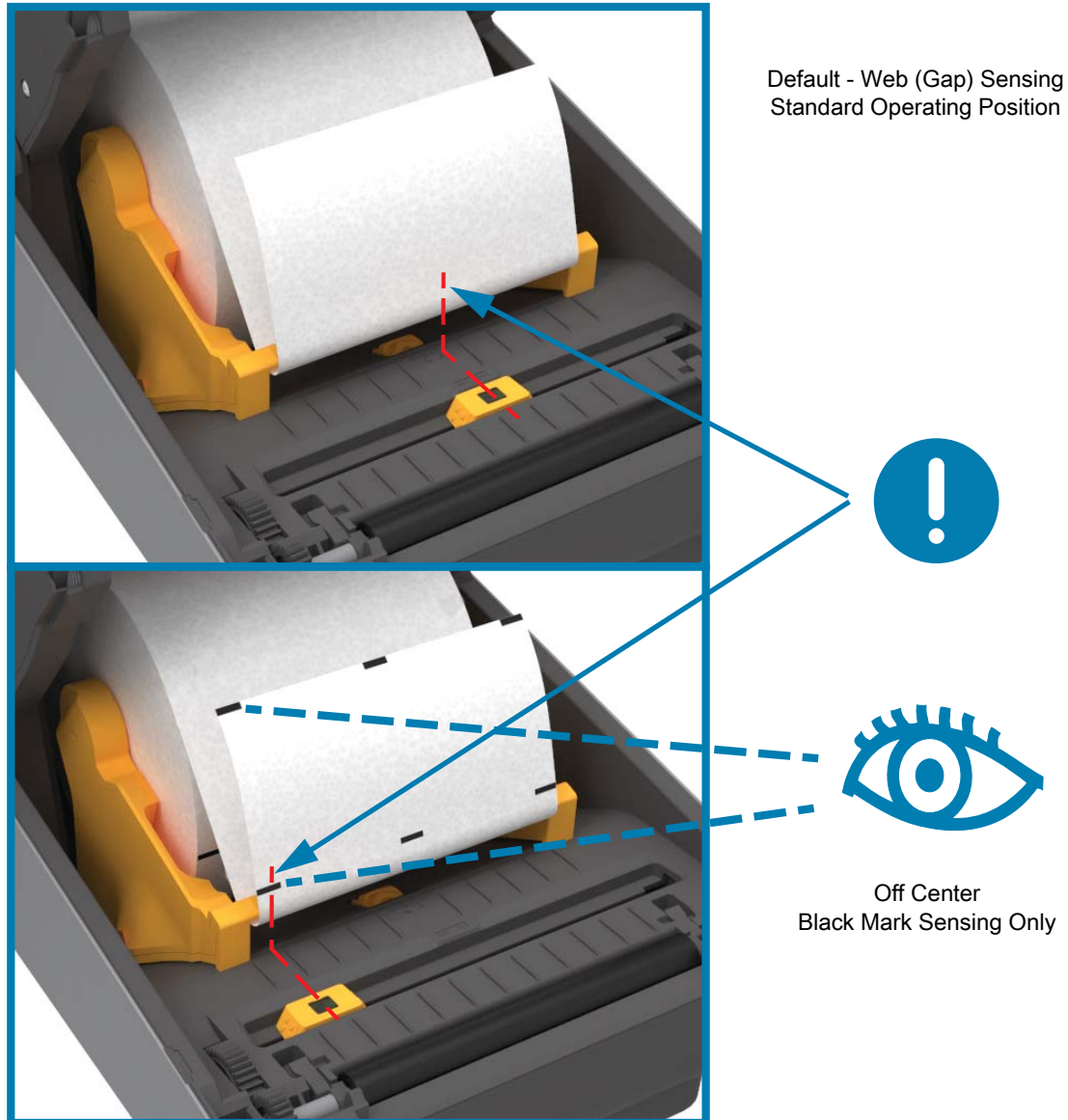

Using the Movable Sensor

The movable sensor is a dual function sensor. It provides transmissive (sees through media) and reflective media sensing. The printer can use either sensing method, but not both at the same time.

The movable sensor has a center array of sensors. This provides adjustable transmissive web (gap) sensing to positions that match legacy Zebra® desktop printer sensor locations and positions in between. This also provides for use of some atypical media variations or irregularly shaped media.

The movable sensor allows the printer to use media with **black marks** or **notches** (holes through the media) on the back side of the media (or media liner). The sensor aligns to the middle of black marks or notches not in the center of the media roll to avoid Web/Gap sensing array.

Adjusting the Movable Sensor for Black Marks or Notches

The black mark sensing looks for non-reflective surfaces such as black marks, black lines, notches or holes on the back of the media which do not reflect the sensor's near infrared light beam back to the sensor's detector. The sensor light and its black mark detector are next to each other under the sensor cover.

Position the movable sensor's alignment arrow to the middle of the black mark or notch in the underside of the media. Sensor alignment should be set as far as possible from the edge of media but where 100% of the sensor window is covered by the mark. When printing, the media can move from side to side $\pm 1\text{mm}$ (due to media variations and edge damage due to handling). Notches cut into the side of the media can also become damaged.

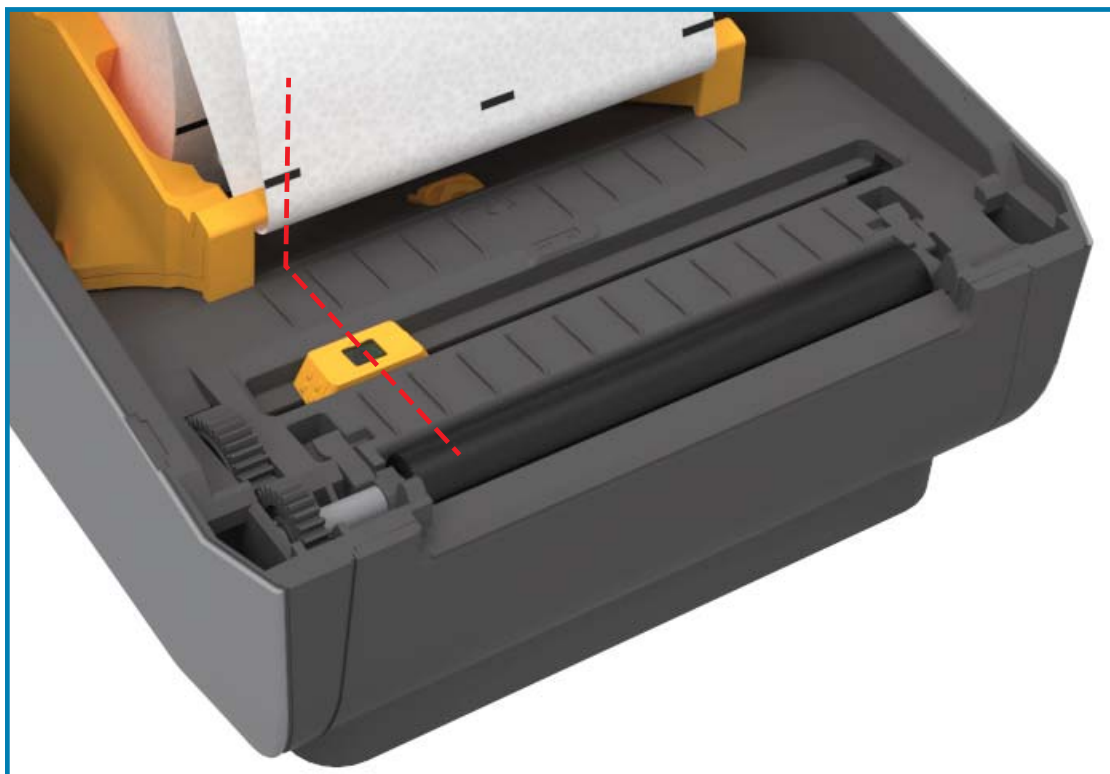

Adjusting the Movable Sensor for Web (Gap) Sensing

The movable sensor for web/gap sensing supports multiple positions.

- The movable sensor's 'Default' position is ideal for most label types.
- The adjustment range is 'from center' to 'off-center' positions which are ideal for printing two (2) labels side by side on a roll.

- The movable sensor adjustment range covers sensor positions use by legacy Zebra printers.
- Web (Gap) sensing with the movable sensor only functions when the movable sensor's alignment arrow points to any position on the alignment key.

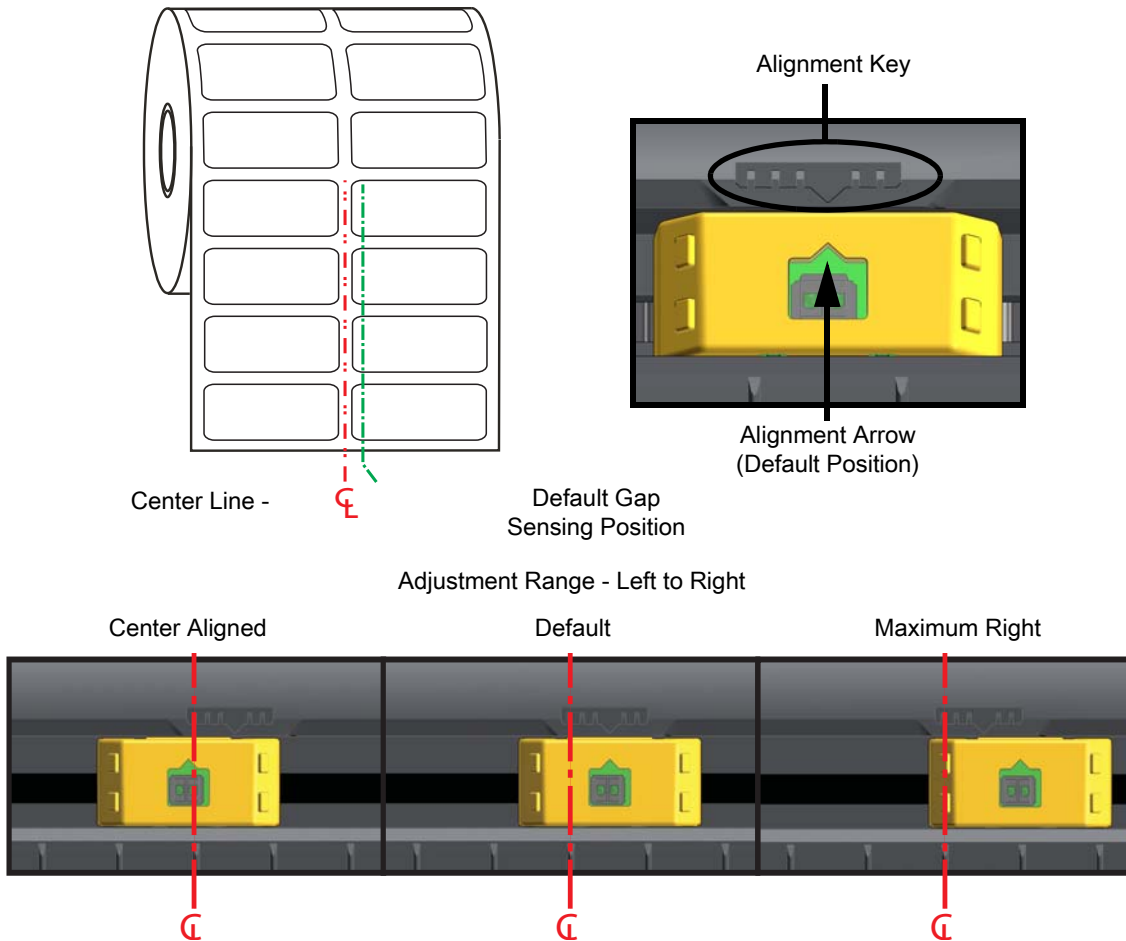

Zebra Printer Models Fixed Sensor Position Relative to a ZD-Series Printer

- **Default** — Zebra Models: G-Series™ fixed position sensors, LP/TLP 2842™, LP/TLP 2844™, LP/TLP 2042™
- **Center Aligned** — Zebra Model: LP/TLP 2742™

Loading Roll Media (continued)

1. **Cutter Models** - For printers with the optional cutter module installed, thread the media through cutter's media slot and pull it out the front of the printer.



2. Close the printer. Press down until the cover snaps closed.



You may need to calibrate your printer for the media. The printer's sensors need to adjust to sense the label, the liner, and the distance between labels to operate properly. When reloading the same media (size, vendor, and batch), you can just press the FEED (Advance) button once to prepare the media for printing.

Loading Thermal Transfer Roll Ribbon

The ZD621 and ZD421 thermal transfer printers have a flexible ribbon system. It supports 300 meter and 74 meter genuine Zebra® ribbons. The printer includes 300 meter ribbon adapters for non-Zebra ribbon rolls. 74 meter ribbon from non-Zebra printers does not need the Non-Zebra ribbon adapters to operate properly.

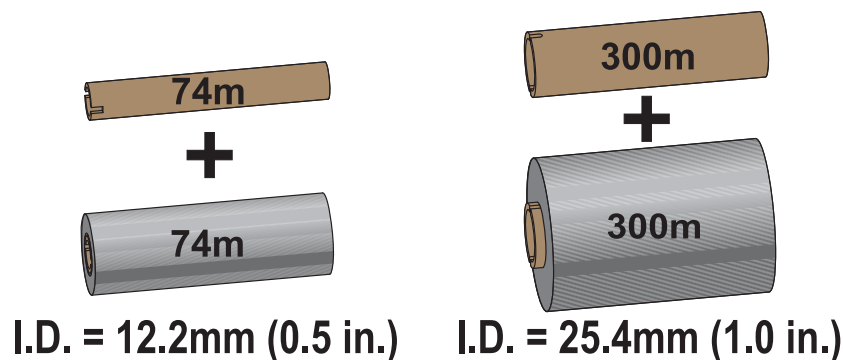

Transfer ribbons come in several varieties and in some cases colors to match your application needs. Genuine Zebra® transfer ribbons are specifically designed for your printer and Zebra brand media. Using non-Zebra media or ribbons not approved for use in your Zebra® printer may damage your printer or printhead.

- The media and ribbon types should be matched to provide you with optimal print results.
- Always use ribbon that is wider than the media to protect the printhead from wear.
- For direct thermal printing, do not load ribbon in the printer.
- Always use an empty ribbon core that matches your transfer ribbon roll's inner diameter (I.D.). Ribbon wrinkling and other print problems can occur.

Your printer needs to use genuine Zebra® ribbons that have a ribbon out trailer (reflector) to stop printing when roll of transfer ribbon has been used up. Genuine Zebra® ribbons and ribbon cores also include notches used to maintain positive ribbon roll engagement and drive without slipping while printing.

Genuine Zebra® ribbons for this printer include:

- Performance Wax
- Premium Wax/Resin
- Performance Resin for synthetics (6 ips max. speed) and coated paper (4 ips max. speed)
- Premium Resin for synthetics (4 ips max. speed)



IMPORTANT: 74 Meter Ribbons - DO NOT USE early model desktop printer ribbon cores! The older style ribbon cores (and some Non-Zebra ribbons) can be identified by notches on only one side of the ribbon core. These older cores are too large.



IMPORTANT: DO NOT USE ribbon cores with damaged notches - rounded, frayed, smashed, etc. The core notches should be square to lock the core on the spindle or the core may slip causing ribbon wrinkle, poor end of ribbon sensing or other intermittent failures.

Loading Zebra Transfer Roll Ribbon

Before following these steps, prepare the ribbon by removing its wrapping and pulling its adhesive strip free.

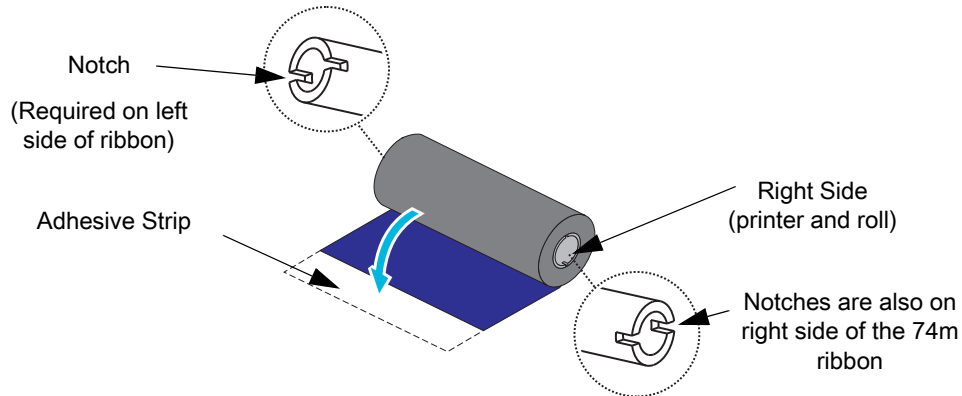

Verify that the ribbon and empty ribbon core have notches on the left side of the ribbon cores as shown above. If they do not, go to [Loading Non-Zebra 300 Meter Transfer Ribbon on page 170](#).

1. With the printer open, place an empty ribbon core on printer's take-up spindles. Push the right side of the empty core onto the spring loaded spindle (right side). Align the core with the center of the left side spindle's hub and rotate the core until the notches align and lock.



NOTE: You can find your first ribbon take-up core in the packing box. Subsequently, use the empty supply core from the supply spindle for the next roll of ribbon.

Setup

2. Place a new ribbon roll on printer's lower ribbon supply spindle. Push it onto the right spindle and lock the left side the same as the take-up mounting the take-up core.

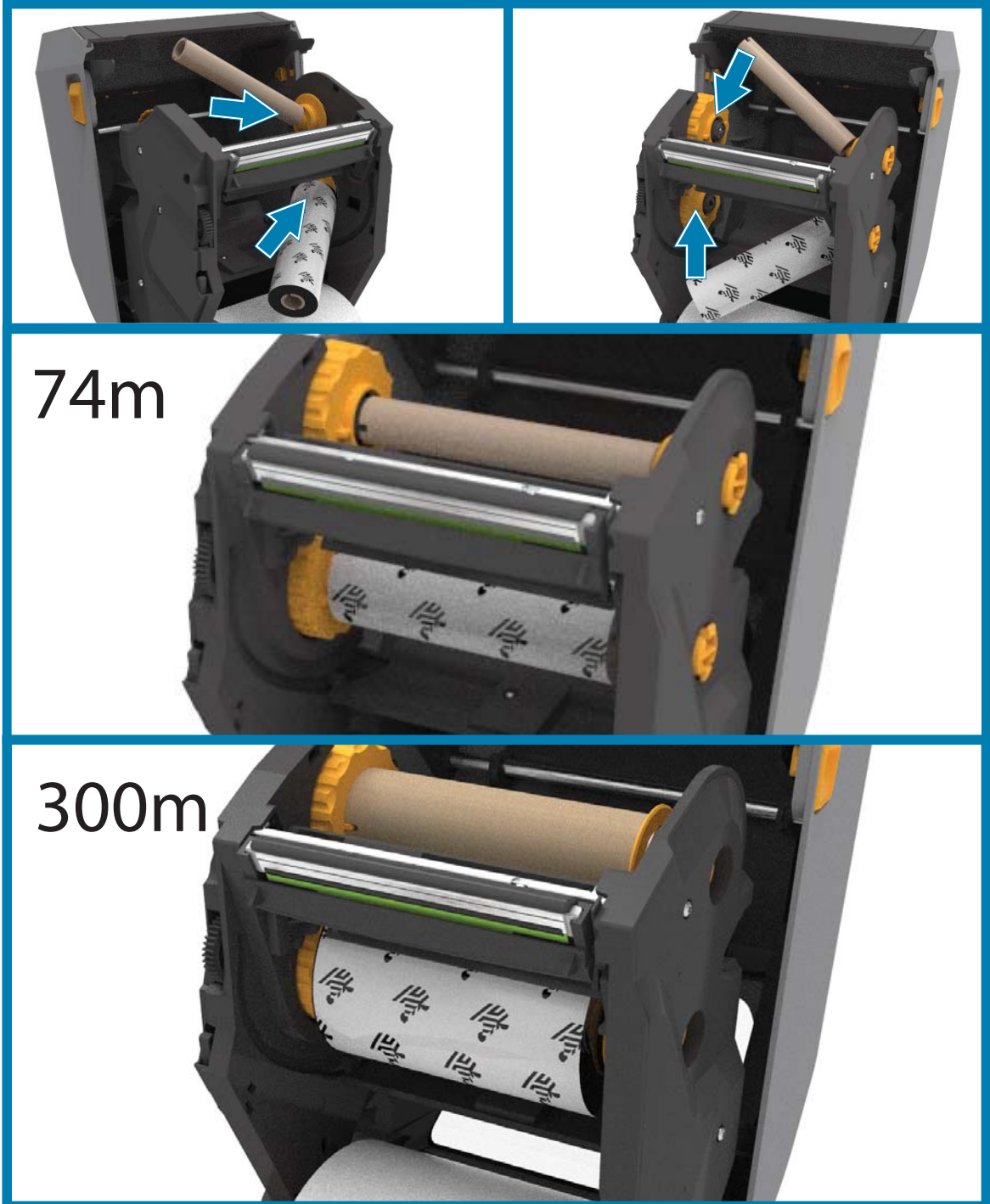

3. Attach the ribbon to the take up core. Use the adhesive strip on new rolls; otherwise, use a thin strip of tape. Align the ribbon so that it will be taken straight onto the core.

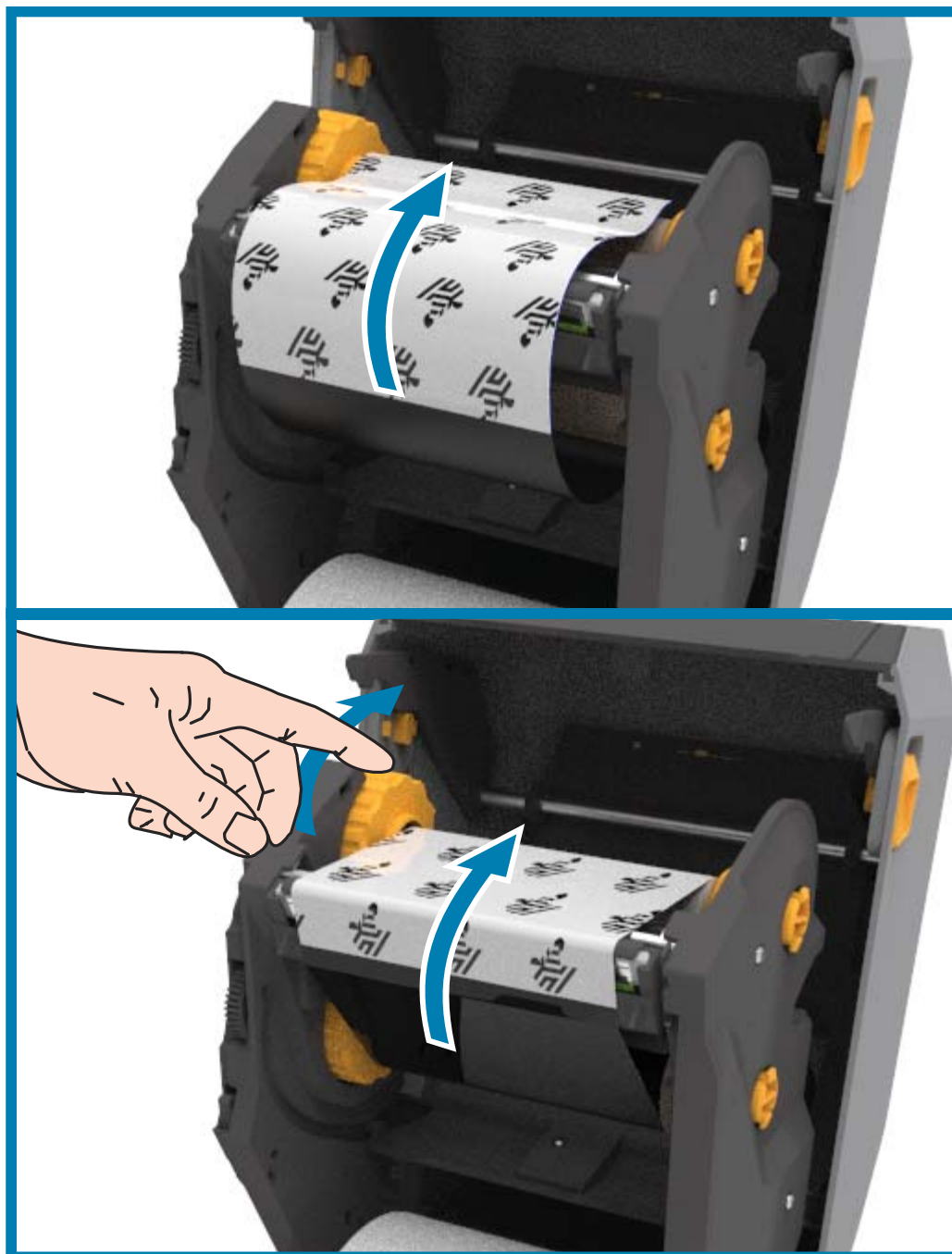

4. Turn the ribbon take-up hub with the top moving toward rear to remove slack from the ribbon. Rotating the hub helps to finish aligning the take up ribbon position to the supply ribbon roll. The ribbon leader should be completely covered by the ribbon.
5. Verify that the media is loaded and ready to print and then close the printer cover.
6. If printer power is on, press the **FEED** button to have the printer advance a minimum of 20 cm (8 in.) of media to remove slack and ribbon wrinkle (straightens the ribbon), and to align the ribbon on the spindles. Otherwise, wait to turn on the printer and complete the printer instructions in this chapter.

7. Change the print mode setting from direct thermal printing to thermal transfer to set the printer's temperature profiles for thermal transfer media. This can be done with the printer driver, application software, or printer programming commands.
 - When controlling printer operations with ZPL programming, refer to the Media Type (^MT) ZPL II command (follow the instructions in the ZPL Programming Guide).
 - When controlling printer operations with EPL Page Mode, refer to the Options (0) EPL command (follow the instructions in the EPL Page Mode Programmer's Guide).

To verify the mode change from direct thermal printing to thermal transfer printing, use the [Test Printing with the Configuration Report on page 178](#) to print a configuration label. The 'PRINT METHOD' should read 'THERMAL-TRANS' on the printer configuration status label.

Loading Non-Zebra 300 Meter Transfer Ribbon

Loading non-Zebra 300 meter transfer ribbon in your printer requires the use of Zebra ribbon core adapters.

Minimum requirements to use non-Zebra 300 meter ribbons with your printer:

- Inside core diameter (I.D.) of 25.4mm (1.0 in., range 1.004 to 1.016 in.).
Material: Fiberboard; hard materials such as plastic cores may not function correctly.
- Ribbon width range of 110 to 33mm (4.3 to 1.3 in.).
- The maximum outer diameter of the ribbon is 66mm (2.6 in.).



CAUTION—PRODUCT DAMAGE: Using non-Zebra media or ribbons not approved for use in your Zebra® printer may damage your printer or printhead. Image quality may also be affected by poor or marginal ribbon performance (maximum print speed, ink formulation, etc.), core material (too soft or hard), and fit (loose or tight ribbon core or exceeds maximum outer diameter - 66mm).

The adapters help you align the ribbon and core to the media (and printer's) center. The adapters include a 'core lock' spring to engage the soft fiberboard inside of the ribbon core and scale measured from the printer's center-line when mounted in the printer.

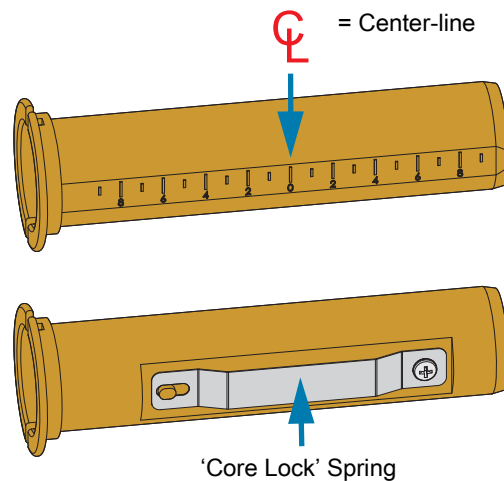

1. Load an empty ribbon core onto a ribbon core adapter. The empty ribbon core should be the same width (or larger) than the ribbon roll. Roughly center the core over the adapter's center line. An empty Zebra ribbon core may be used instead of the adapter and empty non-Zebra ribbon core. One 300m empty ribbon core is supplied with the printer.

2. Load the non-Zebra ribbon roll onto the ribbon core adapter. Orient the adapter flange on the left side and verify that the ribbon unwraps on the backside of the roll as shown in the illustration. Roughly center the core over the adapters center line.

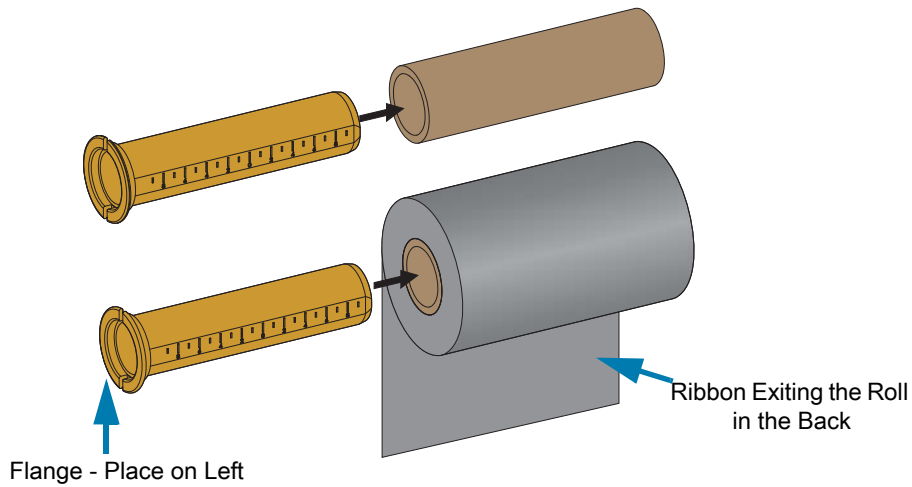

NOTE: The maximum roll width of 110 mm (4.3 in.) does not require centering. For media less than maximum width down to the minimum width of 33mm (1.3 in.), use the graduated scale on the adapter core to align the ribbon rolls to the media and printer.

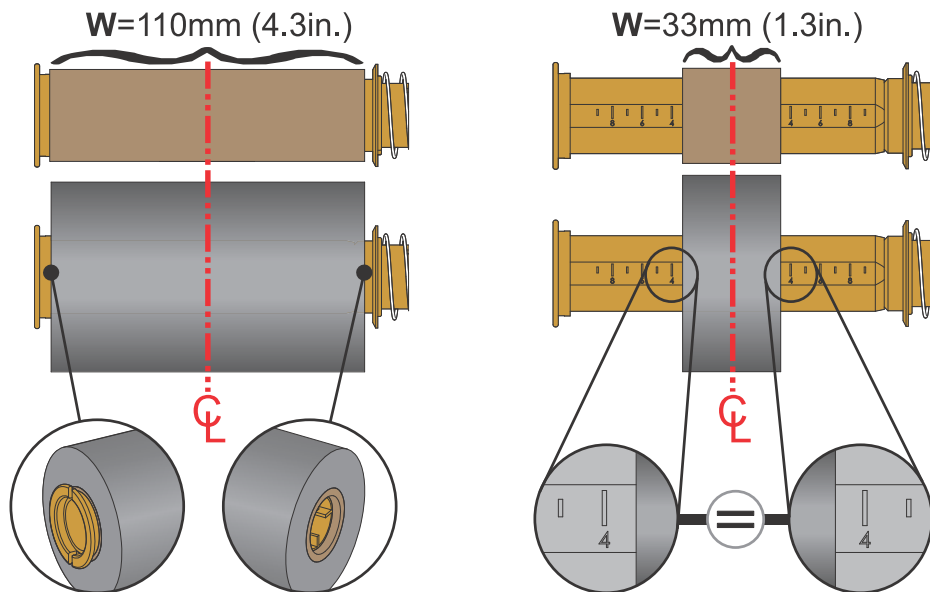

Setup

3. Place the adapter with an empty core on the take-up spindles and the adapter with the ribbon roll on the lower supply spindles. The right side of the core adapter fits on the cone tip on each of the spring loaded right side spindles. Continue pushing the adapter onto right side spindle and swing the adapter onto the left side spindle hubs. Rotate the adapters and hubs until the until notches on the adapters flange align and lock ton the left spindles hub spokes.

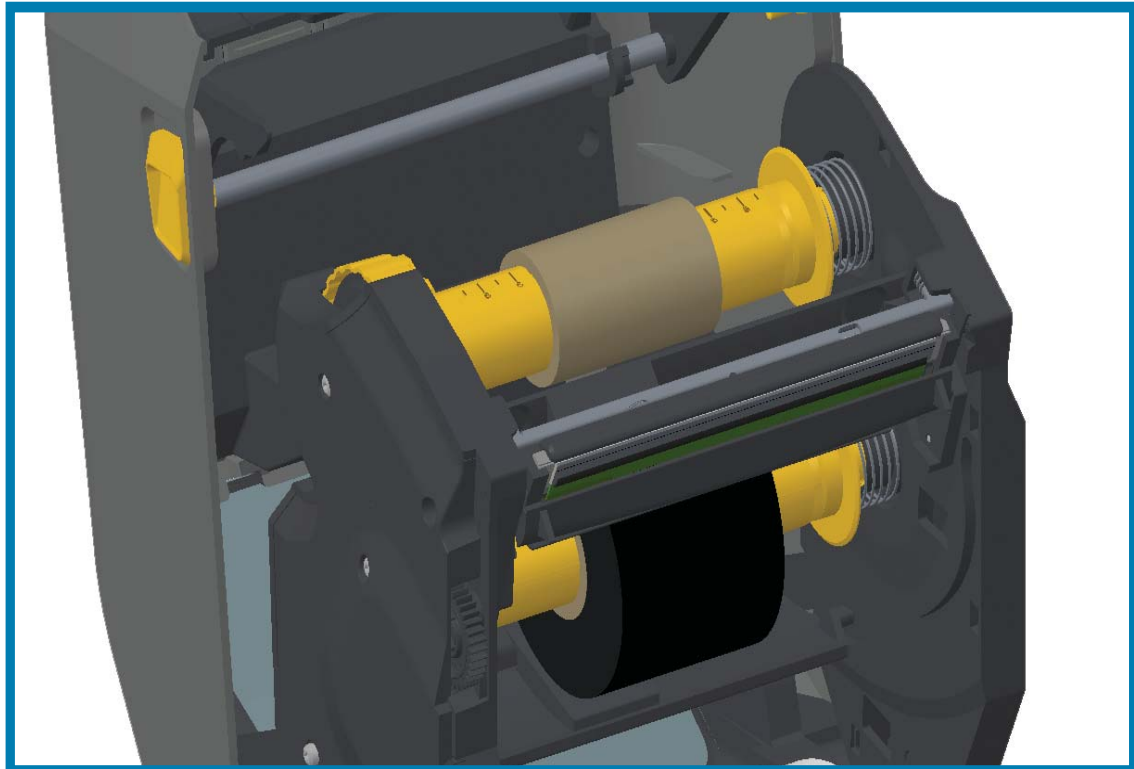
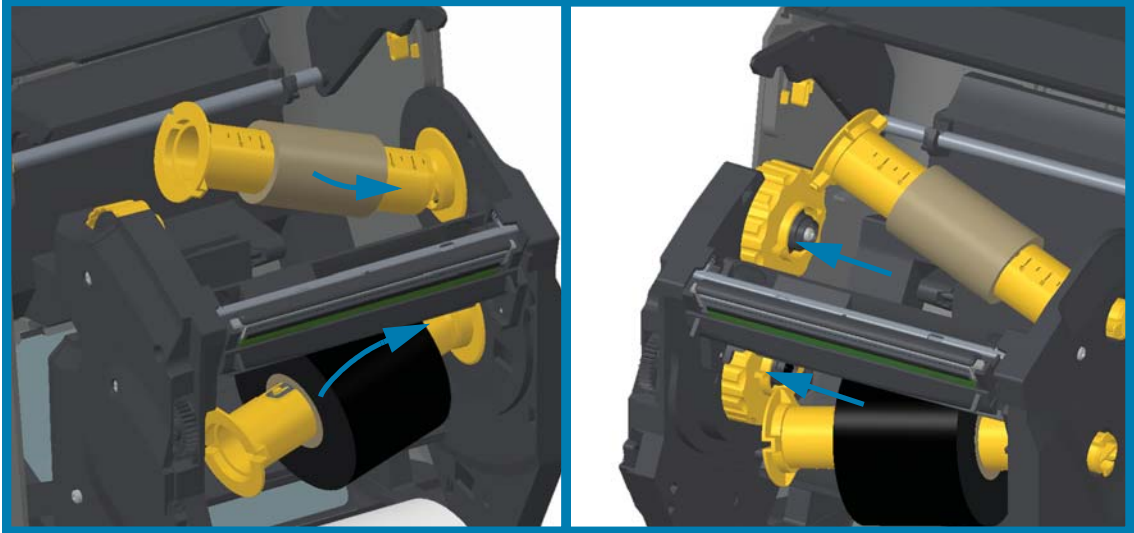

4. While the ribbon and empty cores were being installed during the previous steps, they may have been bumped off center.
 - Verify that the ribbon roll and empty core are aligned to the center of the media (labels, paper, tags, etc.). Remember that you can use the center line scales on the ribbon core adapter to place their positions.
 - If you have forgotten to check if the ribbon is wide enough for the media in use, now is the time to check. The ribbon must be wider than the media (including the label liner or backing) to protect the printhead.

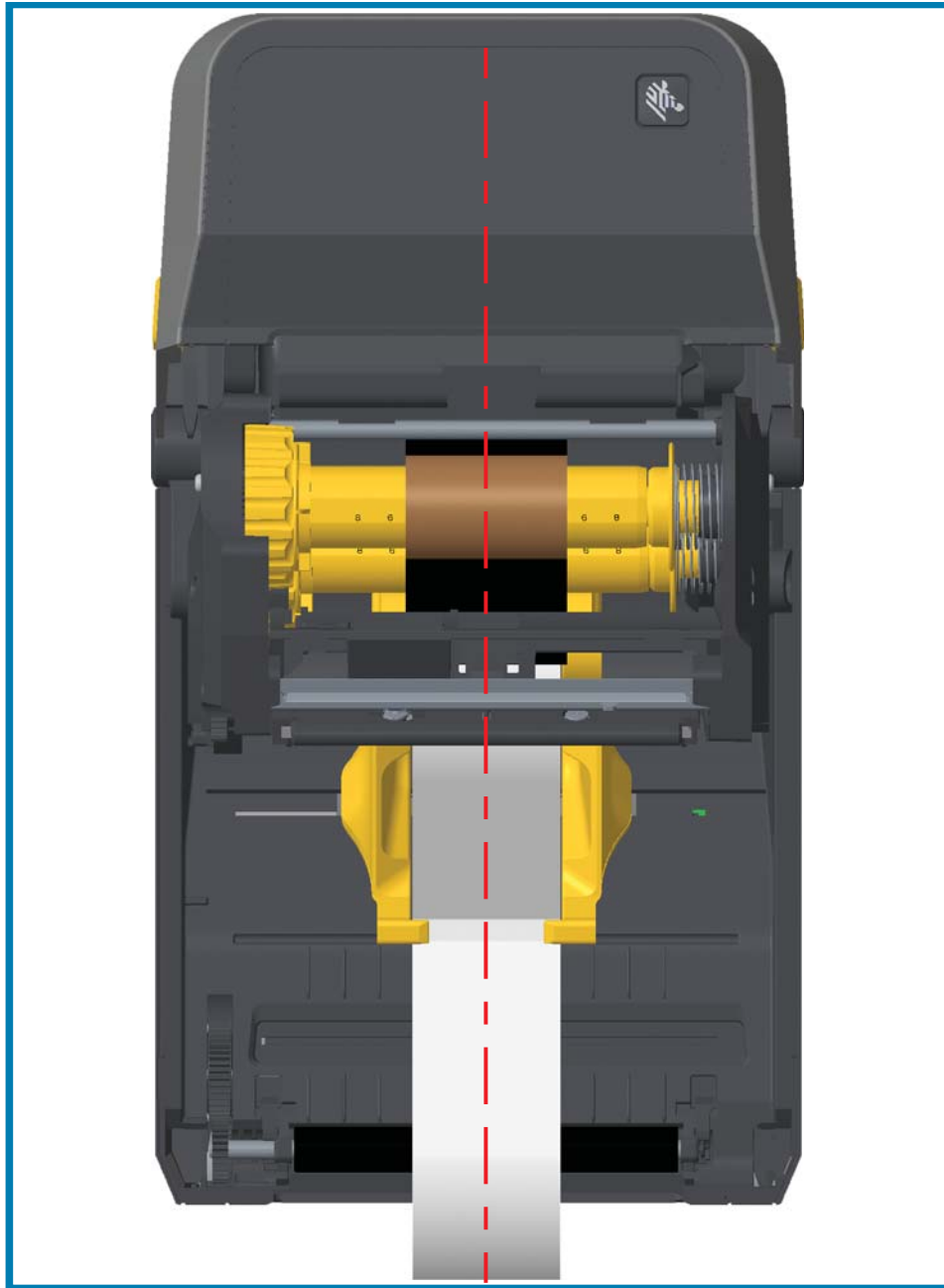

5. Attach the ribbon to the take up core. Use thin strip of tape to secure the ribbon to the take-up core, if your media does not have an adhesive strip on the ribbon leader like genuine Zebra® ribbon. Align the ribbon so that it will be taken straight onto the core.

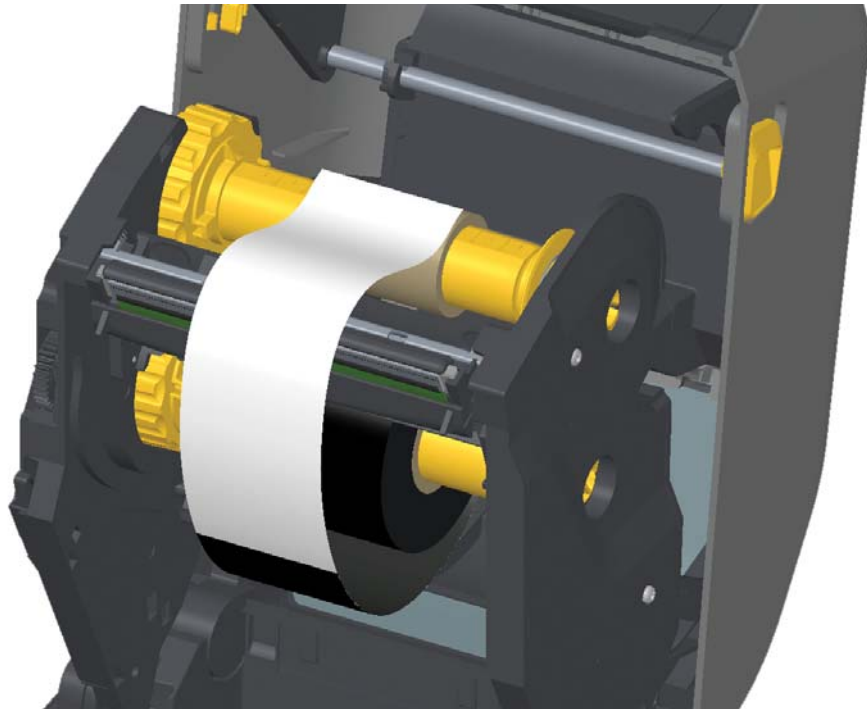

6. Turn the ribbon take-up hub with the top moving toward rear to remove slack from the ribbon. Rotating the hub helps to finish aligning the take up ribbon position with the supply ribbon roll. The ribbon should be wound, at minimum, one and a half times around the take-up ribbon core.

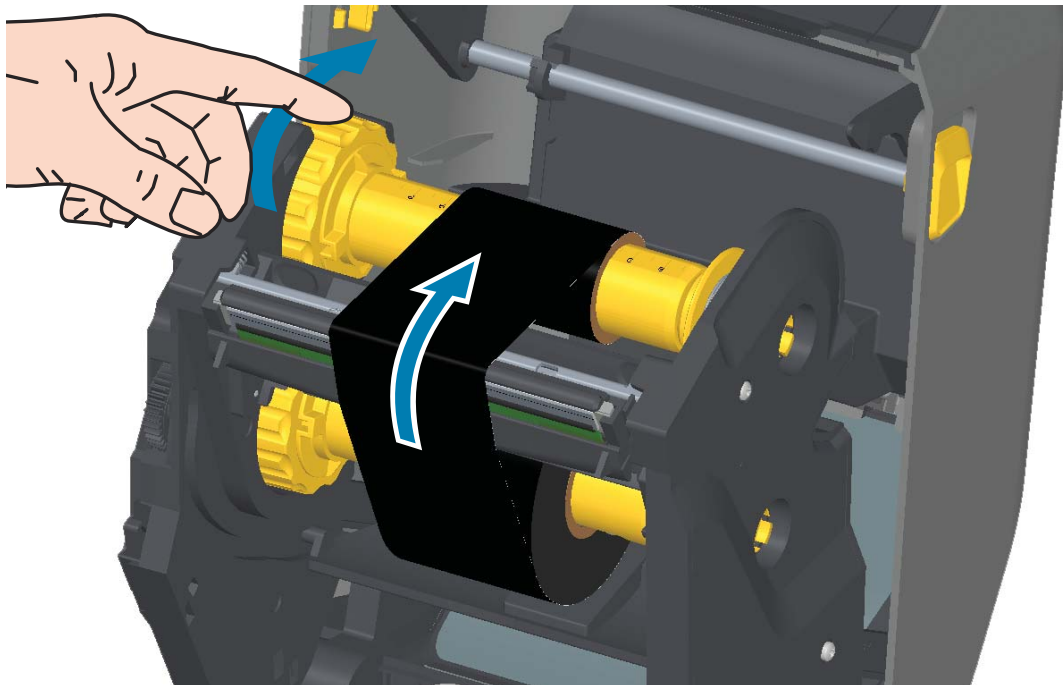

7. Verify that the media is loaded and ready to print and then close the printer cover.
8. If printer power is on, press the FEED button to have the printer advance a minimum of 20 cm (8 in.) of media to remove slack and ribbon wrinkle (straightens the ribbon), and to align the ribbon on the spindles. Otherwise, wait to turn on the printer and complete the printer 'Getting Started' instructions in this chapter.
9. Change the print mode setting from direct thermal printing to thermal transfer to set the printer's temperature profiles for thermal transfer media. This can be done with the printer driver, application software, or printer programming commands.
 - When controlling printer operations with ZPL programming, refer to the **Media Type (^MT)** ZPL II command (follow the instructions in the ZPL Programming Guide).
 - When controlling printer operations with EPL Page Mode, refer to the **Options (0)** EPL command (follow the instructions in the EPL Page Mode Programmer's Guide).
10. To verify the mode change from direct thermal printing to thermal transfer printing, use the [Test Printing with the Configuration Report on page 178](#) to print a configuration label. The 'PRINT METHOD' should read 'THERMAL-TRANS' on the printer configuration status label.

Your printer is now ready to print.

Loading the ZD421 Ribbon Cartridge

The printer uses a transfer ribbon cartridge for thermal transfer printing. Just slide the cartridge into the ribbon transport and close the printer. The printer reads cartridge information stored on the cartridge.

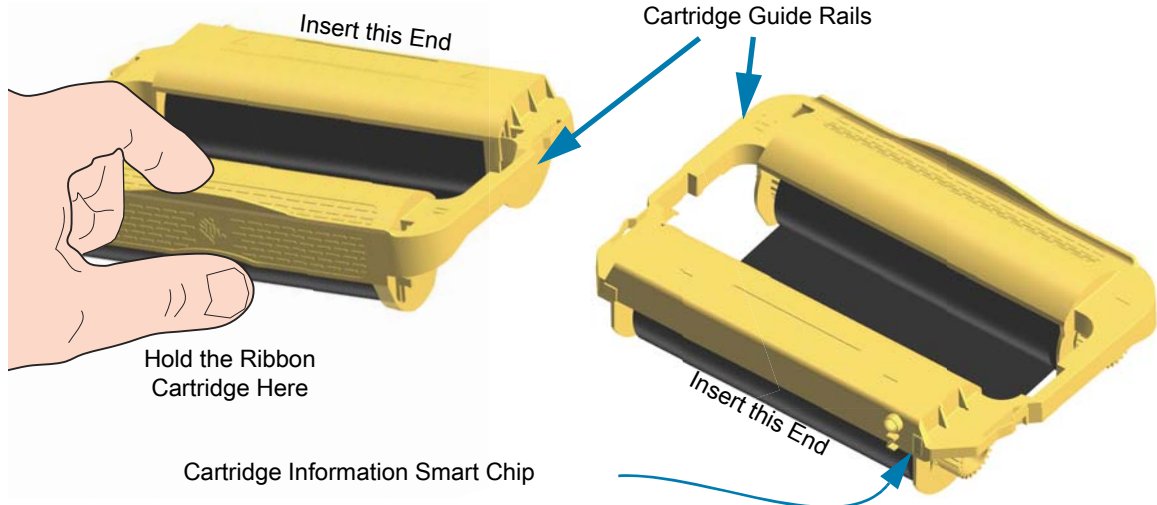

1. Insert the ribbon cartridge into the ribbon cartridge slot on the ribbon transport in your open printer. Push until the cartridge is nearly flush to the front of the ribbon transport. You will hear and feel the cartridge lock into place. Only Genuine Zebra Ribbon Cartridges are supported.

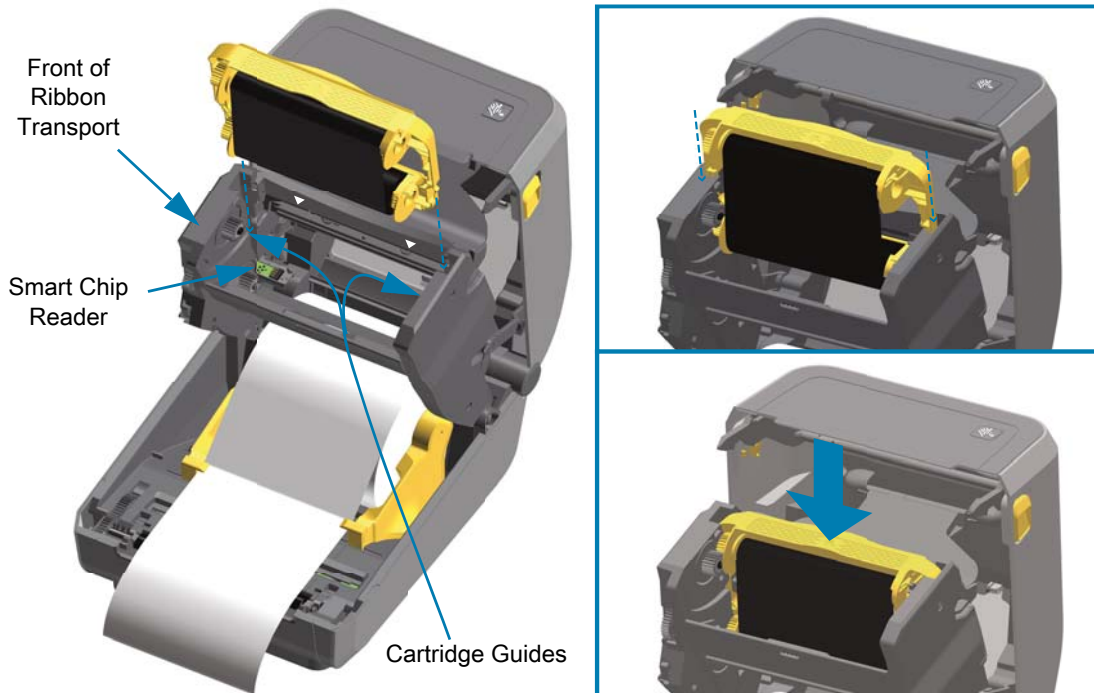

Run a SmartCal Media Calibration

The printer needs to set the media parameters for prior to printing optimal operation. The printer will automatically determine media type (web/gap, black mark/notch, or continuous) and measure media characteristics.



IMPORTANT: After the initial calibration to a specific media is completed, it is not required to perform additional calibrations each time the media is replaced. The printer automatically measures the media to adjust for small changes in the media characteristics while printing. Pressing the FEED (Advance) once or twice after a new roll of media (same batch) has been installed will synchronize the labels. It is then ready to continue printing.

SmartCal Procedure

1. Make sure the media and ribbon cartridge (if you are thermal transfer printing) are loaded properly in the printer and the top cover of the printer is closed.
2. Press the POWER button to turn the printer on.
3. Once the printer is in the ready state (Status indicator is solid green), press and hold the PAUSE and CANCEL button for two (2) seconds and release.
4. The printer will measure a few labels and adjust media sensing levels.
5. When the printer stops, the Status indicator will turn solid green.



Test Printing with the Configuration Report

Before you connect the printer to a computer, make sure that the printer is in proper working order. You can do this by printing a configuration report. The information on the Configuration reports printout that may be helpful with printer installation and with troubleshooting your printer.

1. Make sure the media and ribbon cartridge (if you are thermal transfer printing) are loaded properly in the printer and the top cover of the printer is closed.
2. Turn the printer ON.
3. Once the printer is in the ready state (Status indicator is solid green), press and hold the **FEED and CANCEL** buttons for two (2) seconds and release.
4. The Printer and Network Configuration Reports (shown below) will be printed.
5. When the printer stops, the Status indicator will turn solid green.

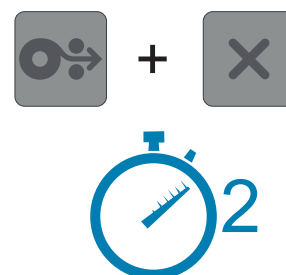

If you cannot get these reports to print, go to [Troubleshooting on page 274](#).

Detecting a Media Out Condition

When you run out of media, your printer will report a 'Media Out' condition with the Status and Media indicators both light solid red. This is part of the normal media usage cycle.



Recovering from a Media Out condition

1. Open the printer.
2. Observe that the media is at the end or nearly at the end of the roll with a label missing from the liner.
3. Remove the remaining media and roll core.
4. Insert a new roll of media. Go to [Loading Roll Media on page 158](#).
 - If you are installing more of the same media, just load the new media and press the FEED (Advance) button once to resume printing.
 - If you are loading different media (size, vendor, or even batch is different), then reloading media followed by a SmartCal is needed to ensure optimal operation.
 - Note that changing media size (length or width) usually requires you to change the programmed media dimensions or the active label format in the printer.



IMPORTANT: Sometimes a label may be missing some where in the middle of your roll of labels (not at the end of media). This will also cause a 'Media Out' condition. To recover, pull the media past the missing label until the next label is over the platen roller. Close the printer. Press the FEED (Advance) button once. The printer will resynchronize the label position and will be ready to resume printing.

Detecting a Ribbon Out Condition

When you run out of printable ribbon, your printer will report a 'Ribbon Out' condition with the Status and Media indicators. This is part of the normal media usage cycle.

When the printer detects that the ribbon is out, the Status indicator will turn solid red and the Media indicator will be flashing red.



Recovering from a Ribbon Out condition

1. Open the printer.
2. Observe a reflective ribbon (used to detect end of ribbon) is exposed on the underside of the ribbon cartridge or ribbon roll. The front ribbon roll is also full.
3. Remove the used ribbon or ribbon cartridge and dispose of it properly. Keep the empty ribbon core (roll) for loading the new ribbon roll.
4. Load new ribbon rolls or Insert a new ribbon cartridge. Go to [Loading Thermal Transfer Roll Ribbon on page 165](#) or [Loading the ZD421 Ribbon Cartridge on page 176](#).
5. Press the FEED (Advance) button once to resume printing.

Connecting your Printer to a Computer

The printer supports a variety of interface options and configurations. These include:

- Universal Serial Bus (USB 2.0) interface - Standard.
- RS232 Serial - ZD621 standard. Field Upgrade Option for ZD421 printers.
- Ethernet (LAN) - ZD621 standard. Field Upgrade Option for ZD421 printers.
- Internal Wi-Fi (802.11ac) and Bluetooth Classic 4.1 - Factory Installed Option.
 - WiFi models include Bluetooth Low Energy (low speed connection) for printer configuration using software running on an Android or iOS device.

Pre-install Windows® Printer Drivers

Install the Zebra Setup Utilities (ZSU) before applying power to the printer connected to the PC. The utility installs the Zebra Windows drivers first. The ZSU installation wizard will then prompt you turn on the printer. Follow the instructions to complete your printer installation.

The Zebra Setup Utility is designed to assist you with installing your printer. The cabling and unique parameters for each of these physical printer communication interfaces is discussed in the following pages to assist you with making configuration setup choices prior to and immediately following applying power. The Zebra Setup Utilities configuration wizards will instruct you to turn the printer's power on at the appropriate time to complete the installation of your printer.

For more details on configuring network (Ethernet or Wi-Fi) and Bluetooth communication, refer to the following guides:

- Wired and Wireless Print Server User Guide
- Bluetooth Wireless Guide

Interface Cable Requirements

Data cables must be of fully shielded construction and fitted with metal or metalized connector shells. Shielded cables and connectors are required to prevent radiation and reception of electrical noise.

To minimize electrical noise pickup in the cable:

- Keep data cables as short as possible (1.83 m [6 foot] recommended).
- Do not tightly bundle the data cables with power cords.
- Do not tie the data cables to power wire conduits.



IMPORTANT: This printer complies with FCC "Rules and Regulations," Part 15, for Class B Equipment, using fully shielded data cables. Use of un-shielded cables may increase radiated emissions above the Class B limits.

USB Interface

Universal Serial Bus (version 2.0 compliant) provides a fast interface that is compatible with your existing PC hardware. USB's "plug and play" design makes installation easy. Multiple printers can share a single USB port/hub.

When using a USB cable, verify that the cable or cable packaging bears the "Certified USB™" mark to guarantee USB 2.0 compliance.

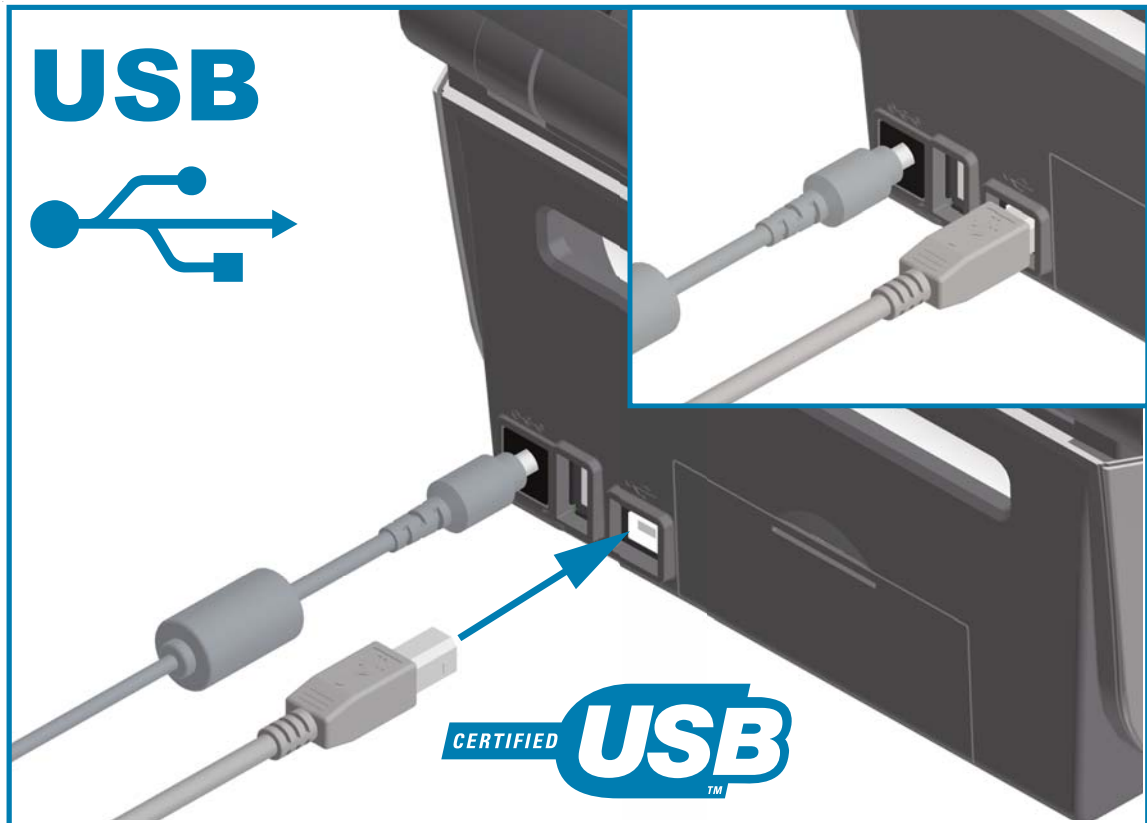

Serial Interface

The printer uses a Null Modem (cross-over) cable for DTE communications. The required cable must have a nine-pin "D" type (DB-9P) male connector on one end which plugs into the mating (DB-9S) serial port located on the back of the printer. The other end of this signal interface cable connects to a serial port on the host computer. For pin-out information, refer to Appendix A.

The serial port communication settings between the printer and host (typically a PC) must match for reliable communication. The Bits per second (or Baud rate) and Flow control are the most common settings that get changed.

Serial communications between the printer and the host computer can be set by:

- ZPL programming ^SC command
- Resetting the printer to its default printer configuration.

Factory defaults for serial communication settings are: 9600 baud, 8 bit word length, NO parity, 1 stop bit, and XON/XOFF ('Software' data flow control in the Windows based host system).

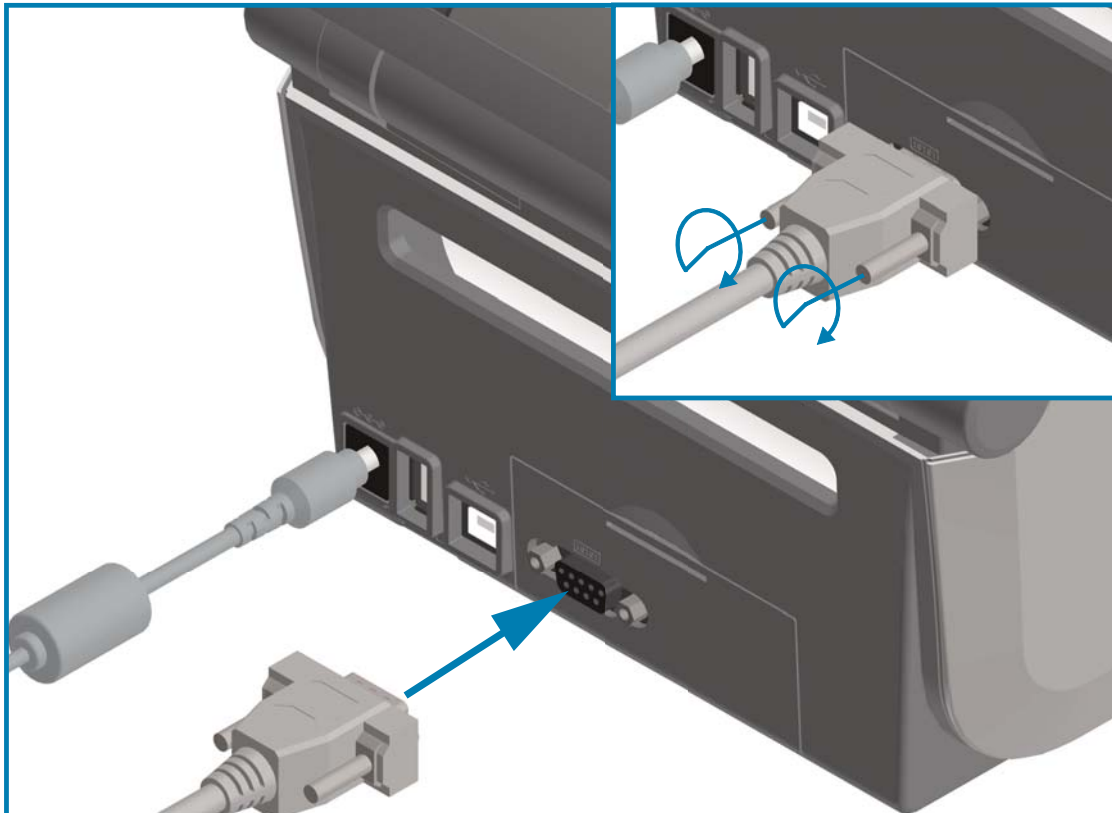

IMPORTANT: Do not use RS-232 cable adapter dongles (DTE<=>DCE) with this printer. Some dongles can interfere with the operation of USB Host port devices at printer power up.

Ethernet (LAN, RJ-45)

The printer requires UTP RJ45 Ethernet cable rated CAT-5 or better.

The printer has a built-in network print server. For more information on configuring your printer to run on a compatible Ethernet based network, refer to the Wired and Wireless Print Server User Guide. The printer must be configured to run on your network. The print server on board your printer can be accessed through the printer's print server Web pages.

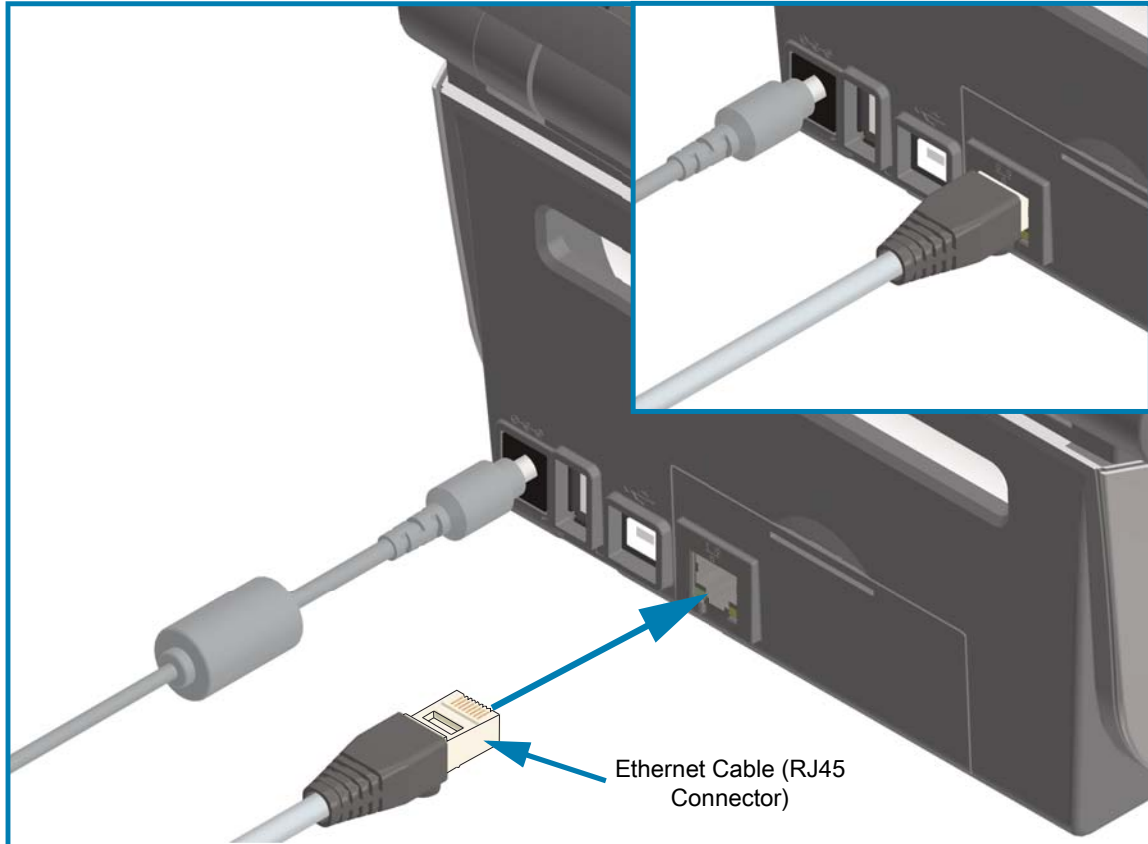

Ethernet Status/Activity Indicators

The Ethernet connector on the printer has two status/activity indicators that are partially visible to provide interface status at the connector. The printer also has the user interface indicator lights for printer network operation status; go to [Meaning of the Indicator Light Patterns on page 41](#) for more details.

LED Status	Description
Both OFF	No Ethernet link detected
Green	100 Mbps link detected
Green with the Amber flashing	100 Mbps link and Ethernet activity detected
Amber	10 Mbps link detected
Amber with the Green flashing	10 Mbps link and Ethernet activity detected

Assigning an IP Address for Network Access

All devices on an Ethernet network (LAN and WLAN) require a network IP (Internet Protocol) address. The printer's IP address is needed to access the printer for printing and printer configuration. The five different ways to assign an IP address are:

- DHCP (Dynamic Host Connection Protocol) - Default setting
- Zebra Setup Utilities (includes the ZebraDesigner Windows printer driver)
- Telnet
- Mobile Apps
- ZebraNet Bridge

DHCP for Personal Networks

The printer by default is set to operate on an Ethernet LAN or Wi-Fi network with DHCP. This setting is intended primarily for personal networks. The network automatically provides a new network IP address each time the printer is turned on. The Windows printer driver uses a Static IP address to connect to the printer. The IP address set in the printer driver will need to be changed to access the printer if its assigned IP address has changed after the printer's initial installation.

Managed Networks

Using the printer in a structured network (LAN or Wi-Fi) requires a network administrator to assign the printer a Static IP address and other settings needed to operate on the network properly.

Print Server - Default User ID and Password

There are some features that require the default User ID and/or default password to access the printer's print server or if you have the Wi-Fi option in the printer. The Factory Default Values are shown below:

- **User ID:** [admin](#)
- **Password:** [1234](#)

Wi-Fi and Bluetooth Classic Wireless Connectivity Option

This guide covers basic configuration of your Internal Wi-Fi Print Server and Bluetooth Classic 4.X wireless connectivity option. This manual only covers installing the Wi-Fi as part of the Wi-Fi and Bluetooth Classic wireless connectivity option in the [Setting Up the Wi-Fi Print Server Option on page 187](#). Refer to the Zebra Web site for Wired and Wireless Print Server User Guide for more information on the printer's Ethernet operation.

This manual only covers installing the Bluetooth as part of the Wi-Fi and Bluetooth Classic wireless connectivity option in the [Bluetooth Option Configuration on page 195](#). Refer to the Zebra Web site for Bluetooth Wireless Guide for more information on the printer's Bluetooth operation.

Update Printer Firmware to Finish Option Installations

It is recommended that you always update the printer's firmware with the latest version for optimal printer performance. For instructions on how to update printer firmware, go to [Updating Printer Firmware on page 273](#). Go to [About on page 11](#) section of this guide to find direct links to printer support pages for your specific Link-OS printer model and Firmware updates.

Setup for Windows[®] OS

The section helps you setup communications between your printer and the Windows operating system environment.

Windows to Printer Communication Setup (Overview)

For supported Windows Operating systems (most common) with a Local (wired) connection:

1. Download the Zebra Setup Utilities from the Zebra web site.
 - ZD621 Thermal Transfer Printer — zebra.com/ZD621t-info
 - ZD621 Direct Thermal Printer — zebra.com/ZD621d-info
 - ZD421 Thermal Transfer Ribbon Cartridge Printer — zebra.com/ZD421c-info
 - ZD421 Thermal Transfer Printer — zebra.com/ZD421t-info
 - ZD421 Direct Thermal Printer — zebra.com/ZD421d-info
 - ZD621R Thermal Transfer Printer — zebra.com/ZD621r-info
2. Run the Zebra Setup Utilities from your Download directory.
3. Click **Install New Printer** and run the install wizard.
4. Select **Install Printer** and select your printer's model number from the list of ZDesigner printers.
5. Select the port (USB or Serial) that you connected to the PC. Use these interfaces to assist Wizard guided installation of networked or Bluetooth Classic (4.0).
6. Turn the printer ON and configure printer communications for your interface type.
7. Use the Windows driver to print a Test Print to verify operation with Windows.

Pre-install Windows[®] Printer Drivers

Install the Zebra Setup Utilities (ZSU) before applying power to the printer connected to the PC (running a Zebra driver supported Windows operating system). The utility installs the Zebra Windows drivers first. The ZSU installation wizard will then prompt you to apply the printer power. Continue to follow the instructions to complete your printer installation.

The Zebra Setup Utility is designed to assist you setting up printer communication on a PC running the Windows operating system. The cabling and unique parameters for each of these physical printer communication interfaces is discussed in the following pages to assist you with making configuration setup choices prior to and immediately following applying power. The Zebra Setup Utilities configuration wizards will instruct you to turn the printer's power on at the appropriate time to complete the installation of your printer.

For more details on installing Ethernet (network) and Bluetooth interfaces:

- Wired and Wireless Print Servers User Guide
- Bluetooth Wireless Guide

Setting Up the Wi-Fi Print Server Option

This section covers basic configuration of your internal Wi-Fi Print Server option. For more detailed information, refer to the **Wired and Wireless Print Servers User Guide**.



NOTE: The wireless radio option, which includes Wi-Fi, Bluetooth classic and Bluetooth low energy, is only available as a factory installed configuration.

You may configure your printer for wireless operation in the following ways. This basic guide covers only the first option, the **Connectivity Wizard**.

- **Through the Connectivity Wizard**, which writes a ZPL script for you. On the last screen of the utility, you may choose to send the command directly to your printer, or you may choose to save the ZPL script to a file. The saved ZPL file has several purposes:
 - The file can be sent to the printer through any available connection (serial, parallel, USB, or wired print server).
 - The file can be resent to the printer after the network settings have been restored to factory defaults.
 - The file can be sent to multiple printers that will use the same network settings.
- **Through ZPL script** that you write yourself. Use the `^WX` command to set the basic parameters for security type. You can send the command through any available connection (serial, parallel, USB, or wired print server). Refer to the ZPL Programming Guide for more information on this option.
- **Through Set/Get/Do (SGD) commands** that you send to the printer. Begin with `wlan.security` to set the wireless security type. Depending on which security type that you select, other SGD commands will be necessary to specify other parameters. You can send the commands through any available connection (serial, parallel, USB, or wired print server). Refer to the ZPL Programming Guide for more information on this option.

Configure Using the ZebraNet Bridge Connectivity Wizard



NOTE: The preferred tool for connecting and configuring Link-OS printers to cloud, WLAN, and LAN; is now Link-OS Profile Manager. You can get Profile Manager and ZebraNet Bridge Enterprise (local and LAN configurations) utility is available through zebra.com/software. ZebraNet Bridge Enterprise version 1.2.5 or later is required to configure the printer correctly for use.

The Connectivity Wizard, which is part of this software, allows you to configure your printer easily for wireless operation by writing the appropriate ZPL script for you. Use this utility when you are first installing the wireless print server or after you set the network options back to factory defaults.



NOTE: You can only set up one print server at a time with the Connectivity Wizard. To configure multiple print servers (wired and wireless), run the program once for each print server.

To use the Connectivity Wizard, complete these steps:

1. If it is not already installed, install ZebraNet Bridge Enterprise on your computer.

You can get the program from the Zebra Web site at zebra.com/software.

2. Launch the ZebraNet Bridge Enterprise program.

If you are prompted for a serial number, you may click **Cancel**. You will still be able to use the Connectivity Wizard.

3. From the Menu bar, select **Tools > Connectivity Wizard**. The Connectivity Wizard opens.

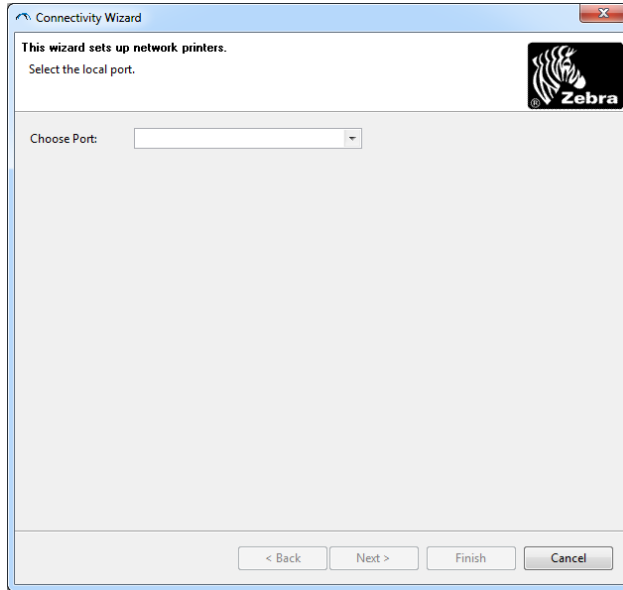

4. From the Choose Port list, select the port to which your printer is connected.

- If you will save the file without sending it to the printer, you may select any available port.
- If you select **File**, you will be asked to browse to the location of the file you want to save.
- If you select a serial port, the serial configuration information appears below the Choose Port list. If necessary, change the serial communication settings to match your printer's settings.



NOTE: If a port is in use by another device, it will not be included in the drop-down list.

5. Click **Next**.

The wizard prompts for the print server device to configure.

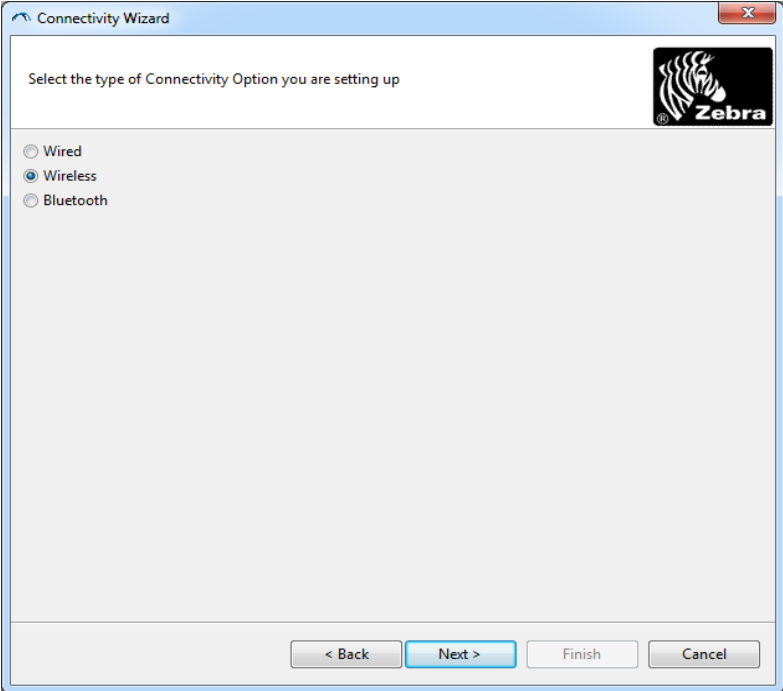

6. Select **Wireless** and then click **Next**.

The wizard prompts you for the type of printer you are using.

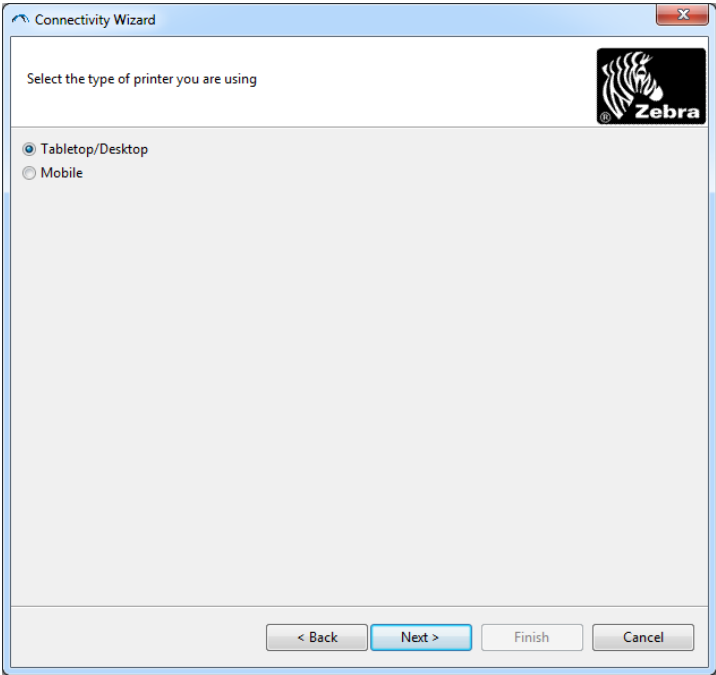

7. Select the type of printer you are using and then click **Next**.

The wizard prompts for the wireless IP information.

8. Enable the DHCP (dynamic) or Static IP option.

- DHCP
 - i. Select **DHCP** and click **Next**.
 - ii. Continue with [step 9](#).
- Static (**IP**)
 - iii. Select **Static**.
 - iv. The IP settings fields are activated.
 - v. Enter the IP Address, Default Gateway, and Subnet Mask for the wireless print server. Contact your network administrator for the correct values.
 - vi. Continue with [step 9](#).

9. Click Next.

The Wireless Settings window opens.

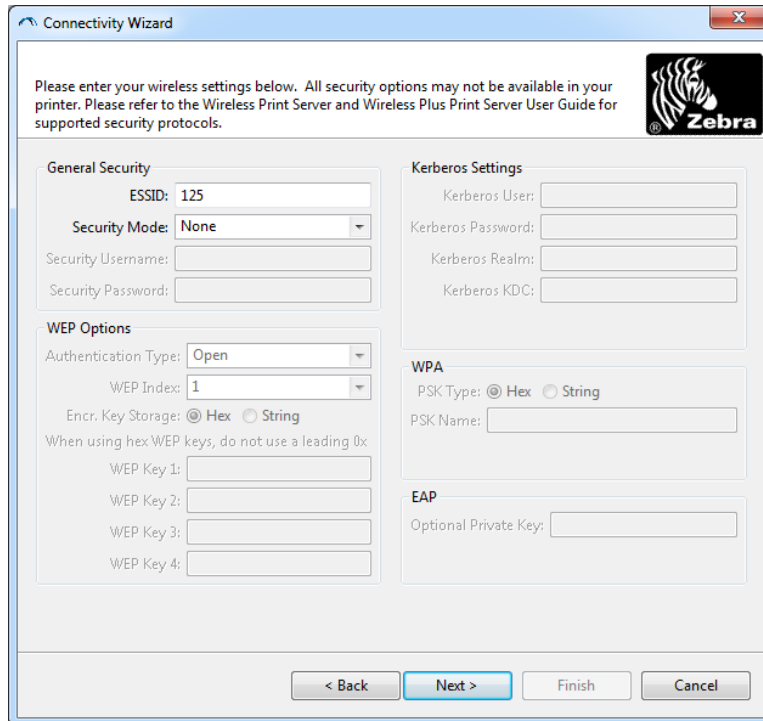

The screenshot shows the 'Connectivity Wizard' window for a Zebra printer. The window title is 'Connectivity Wizard' and it features the Zebra logo in the top right corner. The main text reads: 'Please enter your wireless settings below. All security options may not be available in your printer. Please refer to the Wireless Print Server and Wireless Plus Print Server User Guide for supported security protocols.'

The window is divided into several sections for configuring wireless security:

- General Security:** Includes fields for ESSID (set to '125'), Security Mode (set to 'None'), Security Username, and Security Password.
- WEP Options:** Includes Authentication Type (set to 'Open'), WEP Index (set to '1'), and Encr. Key Storage (radio buttons for 'Hex' and 'String', with 'Hex' selected). Below this are four fields for WEP Key 1, WEP Key 2, WEP Key 3, and WEP Key 4. A note states: 'When using hex WEP keys, do not use a leading 0x'.
- Kerberos Settings:** Includes fields for Kerberos User, Kerberos Password, Kerberos Realm, and Kerberos KDC.
- WPA:** Includes PSK Type (radio buttons for 'Hex' and 'String', with 'Hex' selected) and a PSK Name field.
- EAP:** Includes an Optional Private Key field.

At the bottom of the window, there are four buttons: '< Back', 'Next >', 'Finish', and 'Cancel'. The 'Next >' button is highlighted in blue, indicating it is the active step.

10. Enter the ESSID.



NOTE: The ESSID and pass phrase, if used, must be set at your access point before completing these steps.

11. From the drop-down, select your Security Mode.

- None (no security protocol selected)
- WEP 40-Bit or WEP 128-Bit

In the WEP Options section of the window, enter the following values:

- Authentication Type
- WEP Index
- Encryption Key Storage
- WEP Keys

Click **Next** and continue with [step 12](#).

- EAP-TLS, EAP-TTLS, EAP-FAST, or WPA-EAP-TLS

In the EAP section of the window, if necessary, enter the Optional Private Key.

Click **Next** and continue with [step 12](#).

- PEAP, LEAP, WPA-EAP-TTLS, WPA-PEAP, or WPA-LEAP

In the General Security section of the window, enter the Security Username and Password.

Click **Next** and continue with [step 12](#).

- WPA-PSK

In the WPA section of the window:

- i. Select the **PSK Type**.
- ii. Enter the **PSK Name**.

Click **Next** and continue with [step 12](#)

- WPA-EAP-FAST

iii. In the General Security section of the window, enter the Security Username and Password.

iv. In the EAP section of the window, if necessary, enter the Optional Private Key.

Click **Next** and continue with [step 12](#).

- KERBEROS

In the Kerberos Settings section of the window, enter the following values:

- Kerberos User
- Kerberos Password
- Kerberos Realm
- Kerberos KDC



NOTE: KERBEROS is not supported on Internal Wireless Plus print servers or radio cards.

Click **Next** and continue with [step 12](#).

12. Click **Advanced Options** in the Wireless Settings window.

The Advanced Wireless Settings window opens.

Advanced Wireless Settings
Here you can choose your advanced wireless options.

General
Radio Type: 802.11 b/g (2.4 GHz)
Operating Mode: Infrastructure
Preamble: Long

Antennas
Transmit: Diversity
Receive: Diversity
Transmit Power: 100

Channel Mask
The channel mask specifies the radio channels the printer will use to communicate over.
Preset channel mask: Use Printer Setting
User specified channel mask: 0x

802.11n Settings
Greenfield Mode: Off Aggregation: Off
Reduced Interframe: Off 20 MHz Mode: Off
20 MHz Short Guard: Off 40 MHz Short Guard: Off

Front Panel Wireless Password
The wireless password, which is separate from the printer password, protects the wireless LCD items from being seen or changed when it is set to a non-zero value. The factory default is 0000.
Old Password 0 New Password 0

Skip the detection of a wired printserver on boot up?
Note: If running a wireless printer only this will greatly reduce the time needed to associate on the network.

OK Cancel

13. Review the settings in the Advanced Wireless Settings window. Change the settings as necessary, and then click **OK**. The Wireless Settings window returns.

14. Click Next.

Based on your selections in the Wireless Setup Wizard, the program writes the appropriate ZPL commands and displays them for your review. If you selected **Tabletop/Desktop** then the a dialog box similar to this displays.

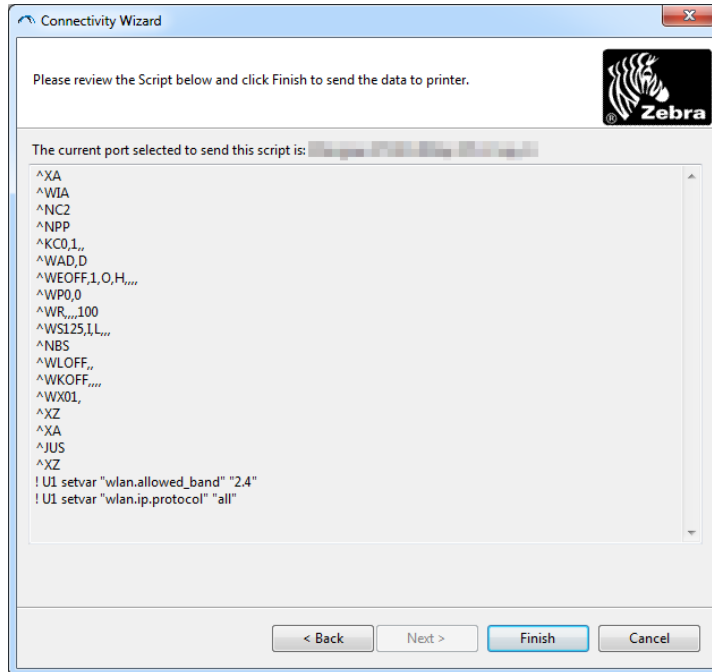

15. Determine if you will send the script immediately, or save it for use at a later time.

Using a Configuration Script

Complete setup by sending the ZPL script to the printer through the port selected at the beginning of this procedure.

1. Verify that the printer is connected to the computer through the wired cable connection to port you selected, USB or Serial.
2. If you have not already done so, turn ON the printer.
3. On the Review and Send ZPL for Wireless window, click **Finish**.
4. The printer sends the ZPL script to the printer through the selected port. The Wireless Setup Wizard screen closes.
5. Turn the printer OFF and then back ON.

Saving a Configuration Script

Save the ZPL script to a file for use later or for use with other printers.



NOTE: You can send the ZPL script file to multiple printers that use the same configuration, or you can send the file to a printer that had the network settings restored to the factory defaults. This saves you from having to go through the Wireless Setup Wizard more than once.

1. On the Review and Send ZPL for Wireless window, highlight the script, right-click, and select **Copy**.
2. Open a text editor, such as Notepad, and paste the script into the application.
3. Save the script.
4. In the Connectivity Wizard, click **Cancel** to exit without sending the script at this time.
5. If you have not already done so, turn ON the printer.
6. Send the ZPL file to the printer through the connection of your choice.
7. Observe the wireless status on the printer's indicator lights, and confirm that you have set up your printer for wireless connectivity.

Bluetooth Option Configuration

The Zebra Setup Utilities provides a quick and easy way to configure a Bluetooth wireless connection with your printer.

1. Double-click the Zebra Setup Utilities icon on your desktop.
2. Connect a USB cable from your printer to your computer.
3. On the first ZSU screen, highlight the printer displayed in the window and click on the **Configure Printer Connectivity** where shown.
4. Select **Bluetooth** on the Connectivity Type screen and click on the **Next** button.



5. On the Bluetooth Settings screen, check **Enabled** to enable Bluetooth functionality.

6. In the Friendly Name text field, set the Bluetooth name of the device. This name appears during device discovery and the central device will label the printer with this name.
7. Set Discoverable to On or Off to set whether the device will appear when central devices are looking for new devices to pair with.
8. Set Authentication to On.



NOTE: This setting does not exist in Link-OS, but you need to turn on if you want to enter a PIN in ZSU. Actual authentication setting on the printer is set in the Security Mode on the Advanced Settings menu.

9. The values set in the Authentication PIN field will vary depending on the Bluetooth (BT) version of the central device. If the central device uses BT v2.0 or older, enter a numeric value in this field. You will be prompted to enter this same value on the central device to verify pairing. Security Mode 2 or 3 in Advanced Settings should also be selected for PIN pairing.



10. If the central device uses BT v2.1 or newer, this setting has no effect. BT v2.1 and newer uses Secure Simple Pairing (SSP) which does not require the use of a PIN.
11. Click the **Advanced Settings** button to display the Advanced Bluetooth Settings window. For more information on Advanced Settings, refer to the **Wired and Wireless Print Server Guide**.
12. Click **Next** to continue configuring your printer.
13. The SGD commands to properly configure your printer will be displayed. Click **Next** to continue to the Send Data screen.
14. On the Send Data screen, click on the Printer that you want to send the commands to or click on the **File** button to save the commands to a file for reuse later.
15. To send the commands to the printer, click on the **Finish** button. The printer will update and then reboot. You may disconnect the USB interface from your printer now.
16. To complete the Bluetooth pairing process, enable Bluetooth device discovery on your central device and follow the directions provided with the device.

Connecting to a Windows XP® SP2 Central Device

This process covers the printer installation for Windows XP SP2 (or above)

1. From the **Windows Start** menu, open the **Printers and Faxes** window. Click on **Add Printer** and a wizard will start. Click **Next** when the “Welcome” window displays to continue.
2. Leave the **Local** radio button with the **Automatic detect ...** checkbox (checked) selected and click **Next**.
3. No printer should be found. If there is one or more new printers detected, then do not select any of those printers and click **Next**.
4. Select the **Create a new port** radio button and select **Bluetooth Printer Port** from the associated pull down menu.
5. From the new **Bluetooth Printer Port** window, select your printer from the Bluetooth devices in the list. This may take several minutes. Click **Connect**.
6. The Install Printer Software window will open. Select **ZDesigner as Manufacture** to select supported Zebra printer models, and then select your printer model in the Printers selection. Click **Next** to continue.
7. Select **Keep the existing drivers** and click **Next**.
8. Name your printer and choose your default printer setting as desired. Click **Next**.
9. Answer **Yes, you want to print a test page**. Click **Next** to continue.
10. Click **Finish** on the **Completing the Add Printer Wizard** window and the Bluetooth printer will complete installation and print a Windows test print page (a Windows logo at minimum).

Connecting to a Windows Vista® SP2 or Windows 7® Central Device

The Windows Vista (SP2 or higher) and Windows 7 Bluetooth install differs from the XP install.

- **Windows Vista:** Open the **Add Printer** wizard by clicking the **Start** button, clicking **Control Panel**, clicking **Hardware and Sound**, clicking **Printers**, and then clicking **Add a printer**.
 - **Windows 7:** Open Devices and Printers by clicking the **Start** button, and then, on the **Start** menu, clicking **Devices and Printers**
 - Some non-Microsoft Bluetooth dongles and built-in Bluetooth devices in the host PCs have marginal driver support for Secure Simple Pairing (SSP) printing and may not complete the Add printer wizard normally. You may need to go to the Bluetooth Devices in the Control Panel or from the system tray on the Windows Start bar and activate SPP for the device, your Bluetooth printer you are installing. Install the printer to a local printer (USB or Serial Port for your Link-OS 4 inch Desktop printer) and then change the Port after the install has completed to the SPP (virtual serial port) COM port.
1. Access the **Devices and Printers** from the Windows **Start** menu.
 2. Check for Bluetooth devices in the **Devices and Printers** window. Note the generic Windows Bluetooth icon below.

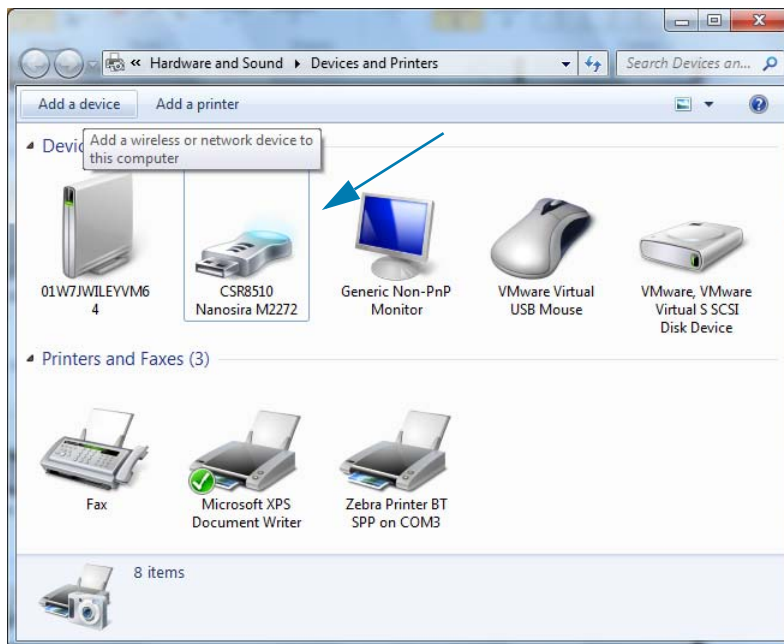

3. Hover over the Bluetooth icon with the mouse pointer and the icon will highlight. Right-Click on the high-lighted Bluetooth icon. Select **Bluetooth Settings** from the pop-up menu. Verify that both of the Connections check boxes are checked. Verify that the Turn off the Bluetooth adapter is not checked. Click the Apply button. Click the OK button to close the window.

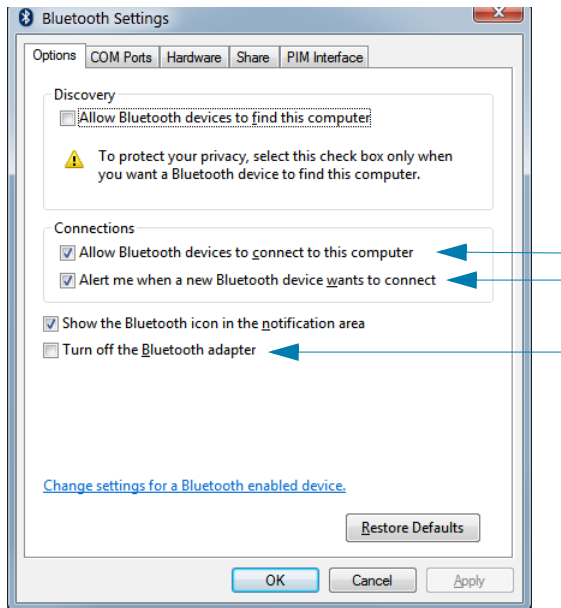

4. Click on the **Add a device** in the top bar of the **Devices and Printers** window. The **Add a device** windows will populate with Bluetooth devices near you.
5. Turn the Bluetooth 4.0 (3.0 compatible) enabled Zebra printer on. After a few moments the **Add a device** windows will add your new printer. Click on the printer icon. Right-click and select **Add device**.

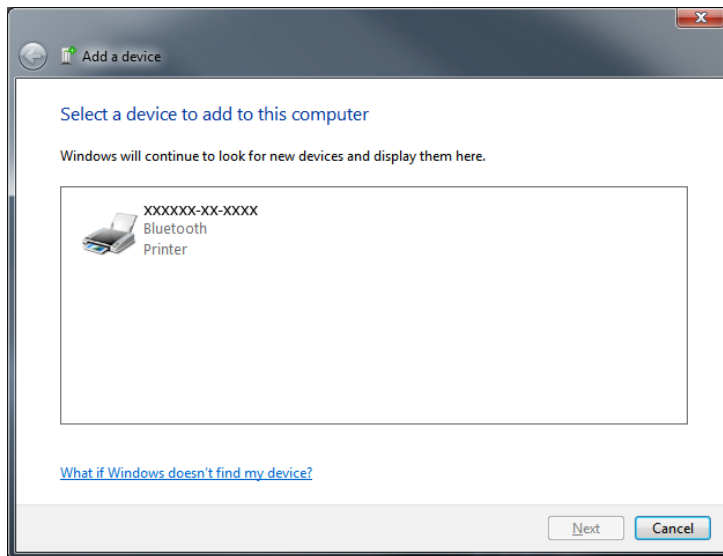

- The printer will print a pairing code. Verify that the pairing numbers match with those on your display screen. If the numbers match, then press the Next button in the Add a device window.



- When the pairing process successfully completes, the following message will be displayed.

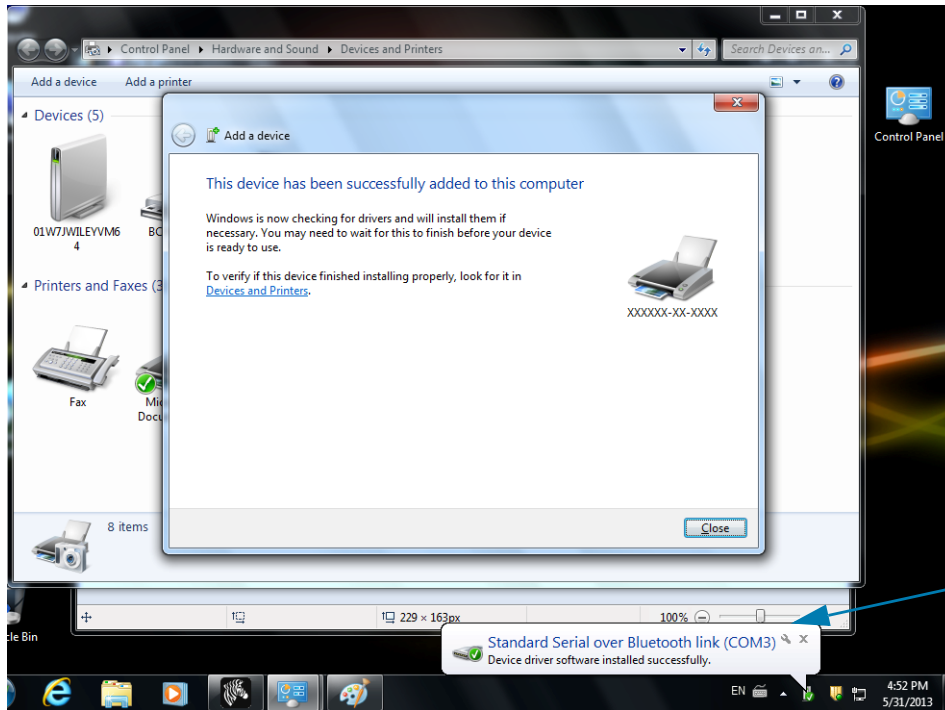

Note • The COM port number displayed in the task bar pop-up. It will only remain for a few seconds.

Connecting the Printer to a Windows 8

Before adding (also called pairing) a Bluetooth enabled device, make sure it is turned on and discoverable. As stated in the previous section under [Connecting to a Windows Vista® SP2 or Windows 7® Central Device on page 199](#), your Windows device may need a Bluetooth adapter to connect to Bluetooth device. Check with your device manufacturers User Manual for further information.

1. Swipe in from the right edge of the screen or move your mouse towards the right edge of the screen, select **Settings**, and then select **Change PC Settings**.

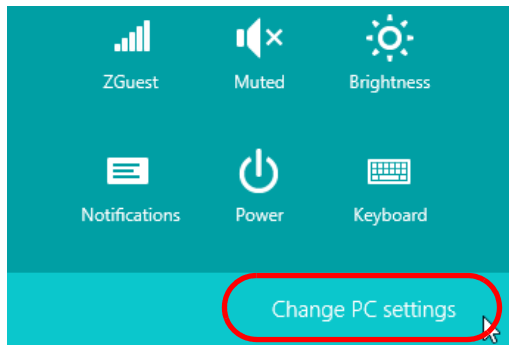

2. Select **PC and devices**, and then select **Bluetooth**. Once Windows displays the Bluetooth-enabled devices, select the device and click **Pair**.

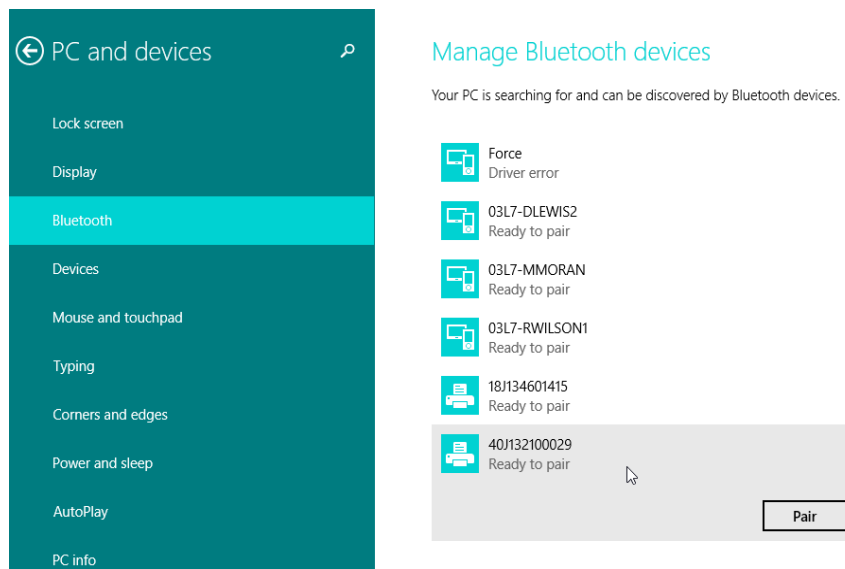

Note • Windows will display the pairing code for only 10 seconds, so complete this step quickly!

3. Follow the instructions on your screen to finish pairing your device.

Connecting the Printer to a Windows 10 PC

Before adding (also called pairing) a Bluetooth enabled device, make sure it is turned on and discoverable. As stated in the previous section under “Installing the Printer on a Windows 7 PC,” your Windows device may need a Bluetooth adapter to connect to Bluetooth device. Check with your device manufacturers User Manual for further information.

1. Open the Windows Start Menu by clicking on the Windows **Start** () button and select **Settings**.

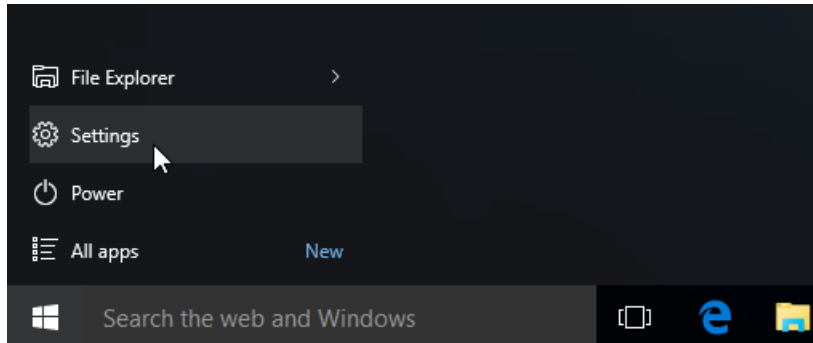

2. Click on the **Devices** category in the **Settings** window.

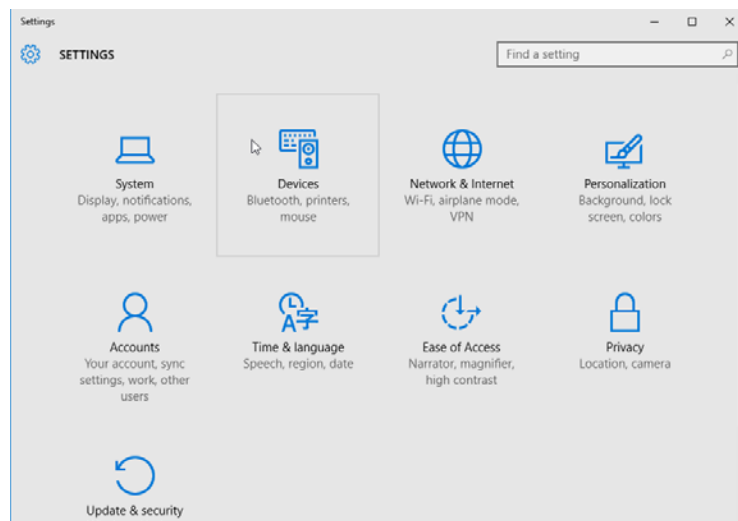

3. Click on **Bluetooth**. If your PC doesn't have Bluetooth installed, the Bluetooth category will not be displayed in the list of device categories. The printer is identified by the serial number.

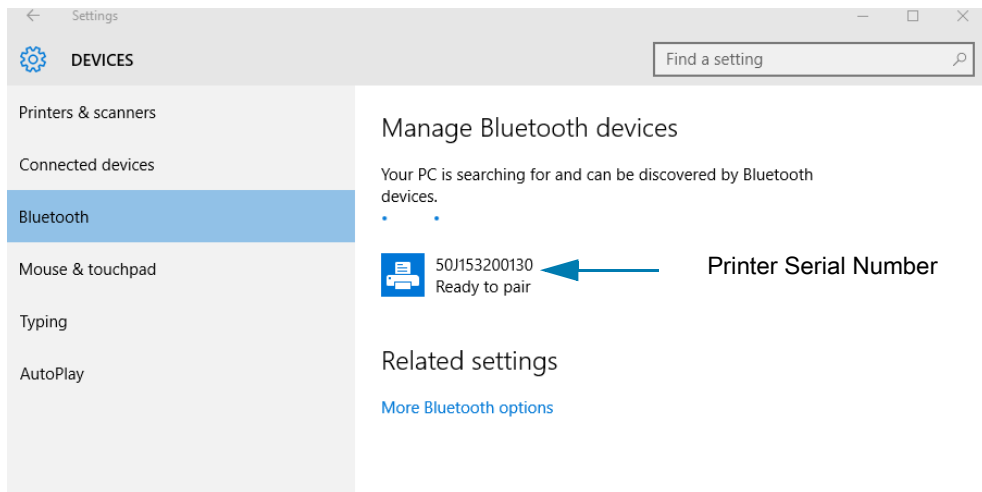

4. Click on the printer and then click on the pairing button for the printer.

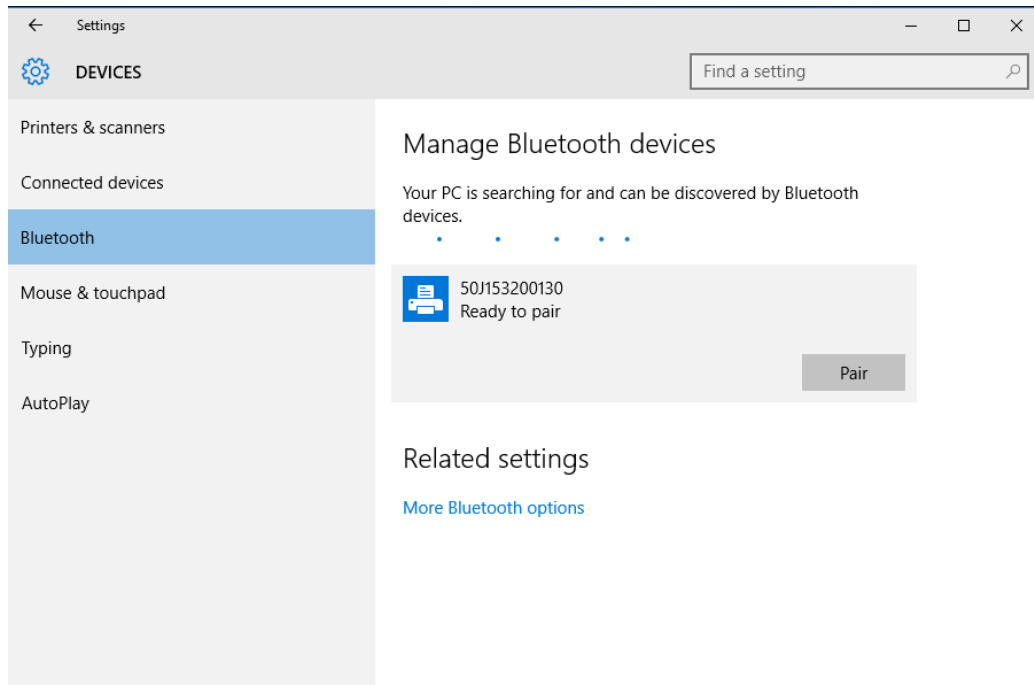

- The printer will print a passcode. Compare that with the passcode showing on screen. Click **Yes** if they match.

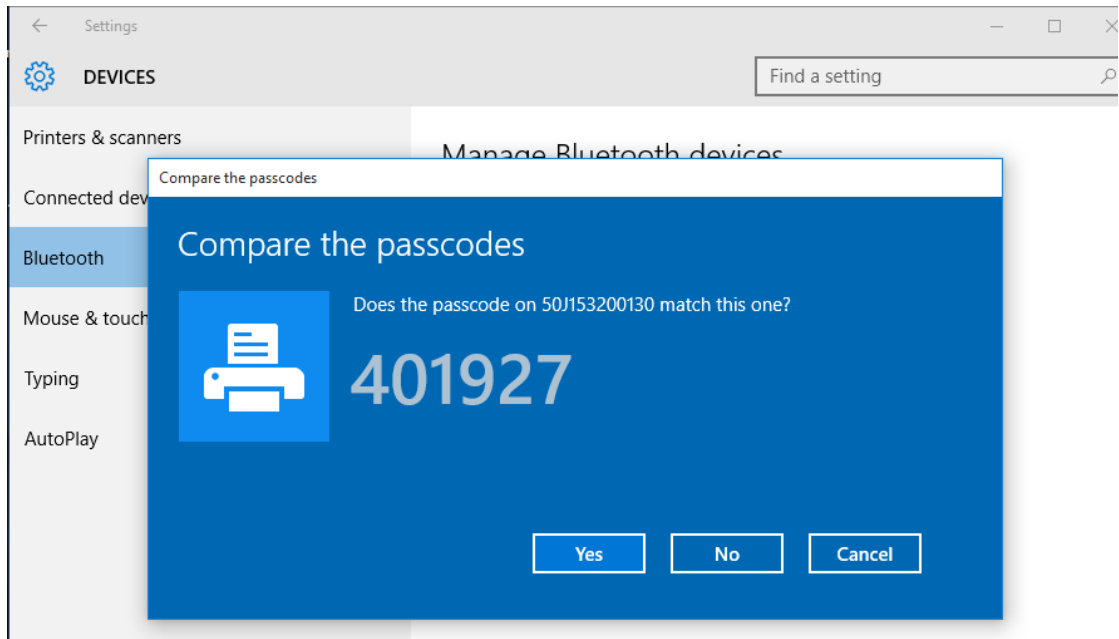

- The printer status changes to connected when pairing has completed.

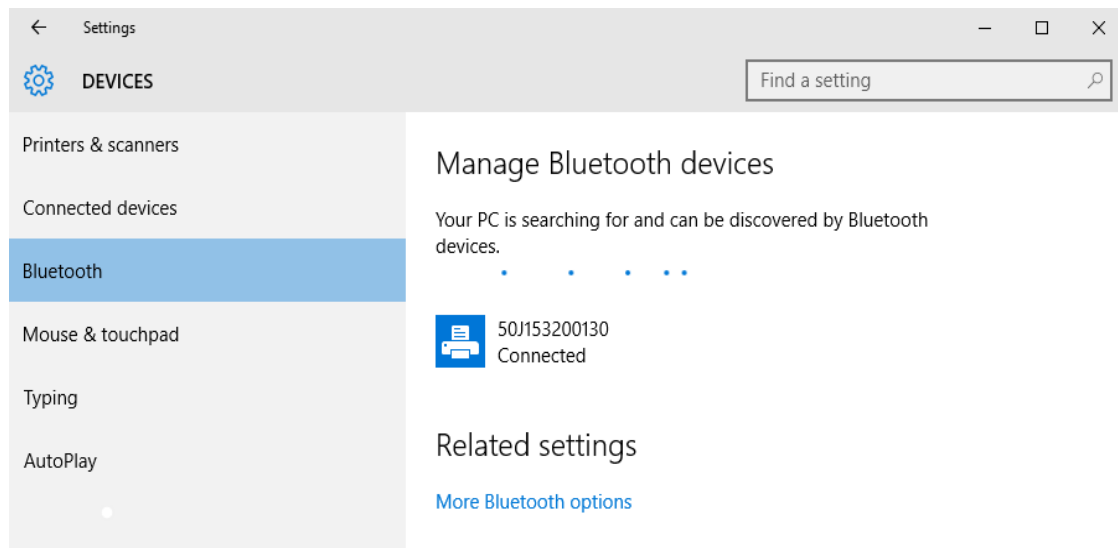

After Your Printer is Connected

Now that you have basic communication to your printer, you may want to test printer communications and then install other printer related applications, drivers or utilities.

Testing Communications by Printing

Verifying the print system's operation is a relatively simple process. For Windows operating systems, use the Zebra Setup Utility or the Windows Printers and Faxes Control Panel to access and print a test label. For non-Windows operation systems, copy a basic ASCII text file with a single command (`~WC`) to print a configuration status label.

Test Printing with Zebra Setup Utility:

1. Open the Zebra Setup Utility.
2. Click on the newly installed printer's icon to select the printer and activate the printer configuration buttons below it in the window.
3. Click the **Open Printer Tools** button.
4. In the Print tab window, click on the **Print configuration label** line and then click on the **Send** button. The printer should print a configuration report.

Test Printing with Windows Printer and Faxes menu:

1. Click on the Windows **Start** menu button to access the Printers and Faxes menu or Control Panel to access the Printers and Faxes menu. Open the menu.
2. Select the newly installed printer's icon to select the printer and right-click the mouse to access the printer Properties menu.
3. From the printer's General tab window, click on the **Print Test Page** button. The printer should print a Windows test print page.

Test Print with an Ethernet printer connected to a network

Test Print on an Ethernet printer connected to a network (LAN or WLAN) with a (MS-DOS) Command Prompt (or Run from the Windows XP Start menu):

1. Create a text file with the following ASCII three characters: **~WC**
2. Save the file as: **TEST.ZPL** (an arbitrary file name and extension name).
3. Read the IP address off the printer's Configuration Reports Network Status printout. On a system that is connected to the same LAN or WAN as the printer, type the following in the Web browser address bar and enter: **ftp (IP address)**.

For IP address 123.45.67.01 it would be: **ftp 123.45.67.01**

4. Type the word put' followed by the file name and enter. For this test print file, it would be:
put TEST.ZPL

The printer should print a new Print Configuration Report.

Test Print with a Copied ZPL Command File for Non-Windows Operating Systems:

1. Create a text file with the following ASCII three characters: ~WC
2. Save the file as: **TEST.ZPL** (an arbitrary file name and extension name).
3. Copy the file to the printer. For DOS, a file sent to a printer connected to the system's serial port would be as simple as:

COPY TEST.ZPL COM1

Other interface connection types and operating systems will have different command strings. Refer to your operating system documentation for detailed instructions to copy to the appropriate printer interface for this test.

Print Operations

This section provides general information on media and print handling, font and language support, and the setup of less common printer configurations.

Thermal Printing

The ZD-Series printers use heat to expose direct thermal media or heat and pressure to melt and transfer 'ink' to the media. Extra care should be taken to avoid touching the printhead which gets hot and is sensitive to electrostatic discharges.



CAUTION—HOT SURFACE: The printhead becomes hot while printing. To protect from damaging the printhead and risk of personal injury, avoid touching the printhead. Only use the cleaning pen to perform printhead maintenance.



CAUTION—ESD: The discharge of electrostatic energy that accumulates on the surface of the human body or other surfaces can damage or destroy the printhead and other electronic components used in this device. You must observe static-safe procedures when working with the printhead or the electronic components under the top cover.

Determining Your Printer's Configuration Settings

ZD-series printer provide a configuration report of the printer's settings and hardware. Operational status (darkness, speed, media type, etc.), installed printer options (network, interface settings, cutter, etc.) and printer description information (serial number, model name, firmware version, etc.) are all included on the configuration report.

- Go to [Test Printing with the Configuration Report on page 178](#) to print this label.
- Go to [Managing the ZPL Printer Configuration on page 339](#) to help interpret the configuration report and the associated programming command and command states it is identifying in the report.

Select a Print Mode or Collection Method

Use a print mode that matches the media being used and the printer options available. The media path is the same for roll and fanfold media.

To set the printer to use an available print mode:

- Go to [Print > Label Position > Collection Method on page 124](#).
- Refer to the ZPL Programmer's manual, ^MM command. Go to [About on page 11](#) for information and support links for your specific printer model.

Print Modes

- **TEAR OFF** — This mode (default) can be used with any printer options and most media types. The printer prints label formats as it receives them. The printer operator can tear off the printed labels any time after they print.
- **PEEL** — Label Dispenser Option only. The printer peels the label from the liner during printing and then pauses until the label is removed.
- **CUTTER** — Cutter Option only. The printer cuts between labels after each one is printed.

Adjusting the Print Quality

Print quality is affected by the heat (density) setting of the printhead, the print speed, and the media in use. Experiment with these settings to find the optimal mix for your application. Print quality can be configured with the Zebra Setup Utility's 'Configure Print Quality' routine.



NOTE: Media manufacturers may have specific recommendations for speed settings for your printer and the media. The recommended speed may be lower than your printer's maximum speed setting!

The darkness (or density) setting can be controlled by:

- The Set Darkness (**~SD**) ZPL command (consult your ZPL Programming Guide).
- Go to [Manual Print Darkness Adjustment on page 305](#).
- Go to [Adjusting the Print Width on page 209](#).

If you find that the print speed needs to be adjusted, use:

- The Windows printer driver or application software such as ZebraDesigner™.
- The Print Rate (**^PR**) command (consult your ZPL Programming Guide).

Use the printer's 'Print Quality Report' (also known as the FEED Self Test) to print a range of labels that help you identify print DARKNESS and SPEED settings for optimizing general print and barcode quality. Go to [Print Quality Report \(FEED self test\) on page 296](#) for details.

The printer's media settings can be verified by printing a Printer Configuration label. Go to [Test Printing with the Configuration Report on page 178](#) for more details.

The maximum distance the automatic media type detection and sensing checks can be reduced using the ZPL Maximum Label Length command (**^ML**). The minimum distance should be no less than two times the longest label being printed. If the largest label being printed was a 2 by 6 in. label, then the maximum label (media) length detection distance can be reduced from the default distance of 39 in. down to 12 in..



NOTE: Go to [About on page 11](#) section for information and support links for your specific printer model.

Adjusting the Print Width

Print width must be set:

- Before you use the printer for the first time.
- Any time you change the width of the media in use.

Print width may be set by:

- The Windows printer driver or application software such as ZebraDesigner™.
- Controlling printer operations with ZPL programming; refer to the Print Width (**^PW**) command (consult your ZPL Programming Guide).
- Go to [Manual Print Width Adjustment on page 304](#).



NOTE: Go to [About on page 11](#) section for information and support links for your specific printer model.

Replacing Supplies while Using the Printer

If media (ribbon, labels, receipts, tags, tickets, etc.) run out while printing, leave the printer power on while reloading (data loss results if you turn off the printer). After you load a new roll of media, press the FEED button to restart.

Printing on Fan-Fold Media

Printing on fan-fold media requires you to adjust the media guides' stop position.

1. Remove media from the printer.
2. Thermal Transfer Printers Only — If your printer has a Fan-Fold Cover installed on your printer, remove
3. Open the top cover.

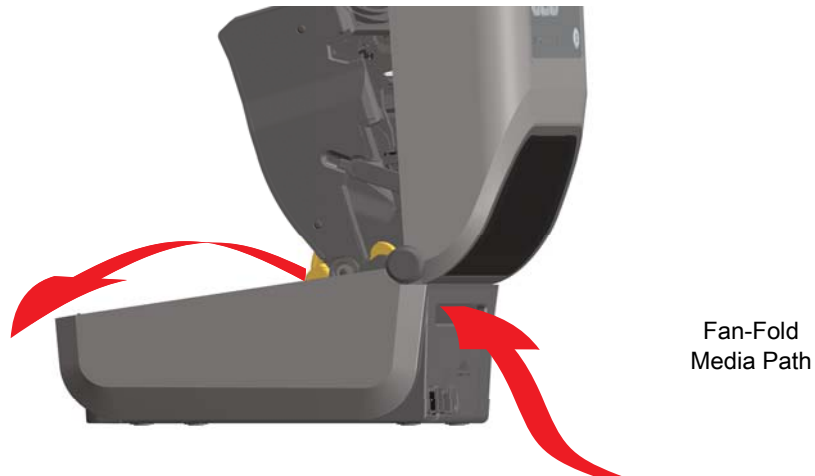

4. For all ZD621 printers and the ZD421 Cartridge printer — Adjust the media guide stop position with the gold thumb wheel. Use a piece of the fan-fold media to set the stop position. Rotate the wheel away from you to make the guides wider. Rotate the wheel toward you to make the media guides narrower.

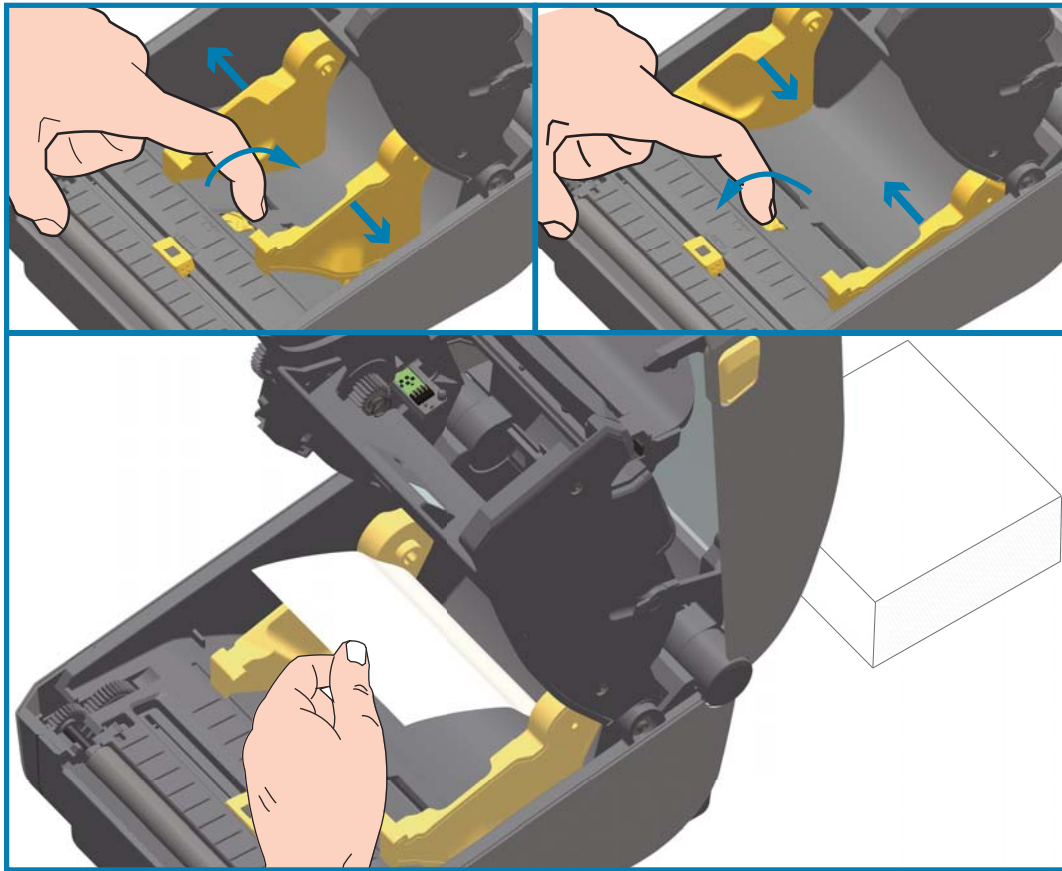

5. For all ZD421 printers except for the ZD421 Cartridge printer — Adjust the media guide stop position with the slide lock on the left side media guide. Use a piece of the fan-fold media to set the stop position. Push the gray down towards the base of the media roll holder to lock the roll position. Rotate the wheel toward you to make the media guides narrower.

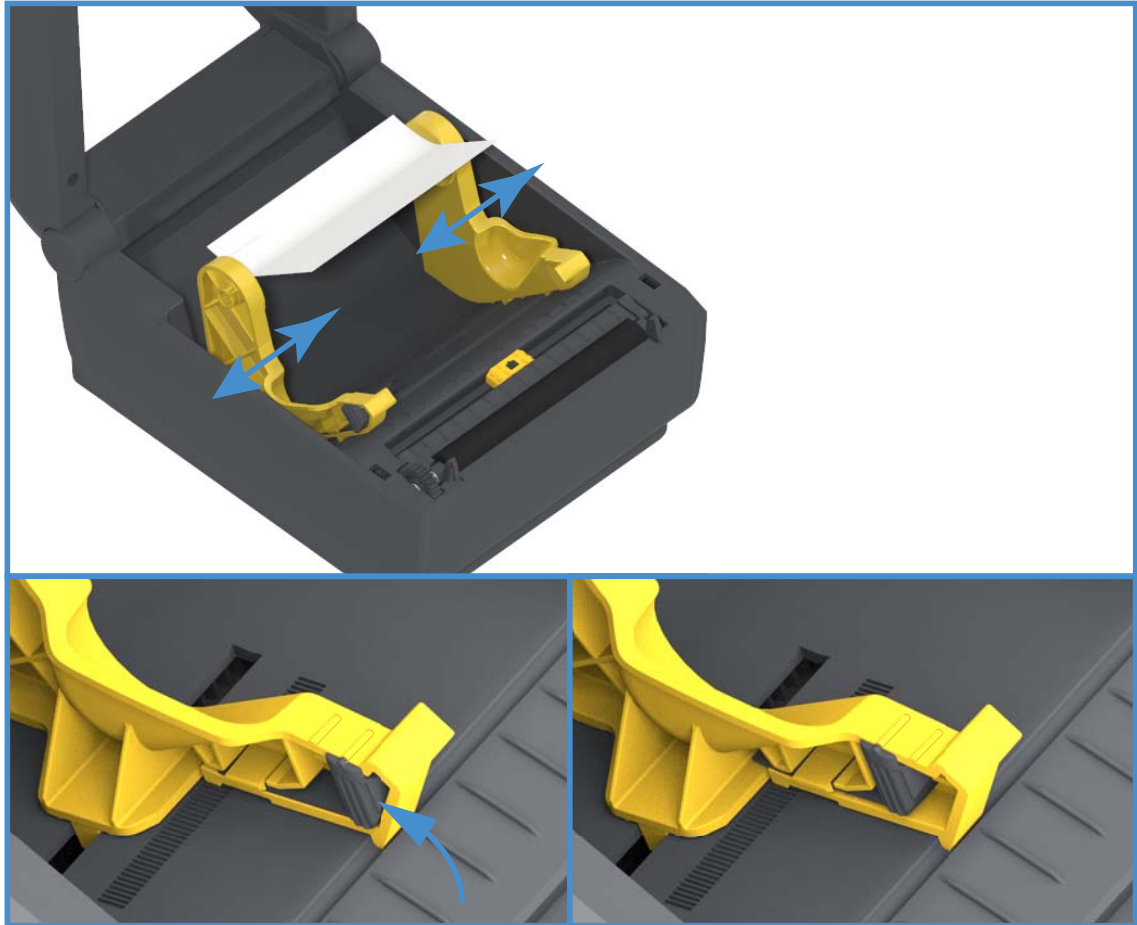

6. Insert the media through the slot at the rear of the printer and place the media between the media guide and roll holders.



7. Close the top cover.



IMPORTANT: After printing or using the FEED button to advance several labels: If the media does not track down the center (moves from side to side) or the sides of the media (liner, tag, paper, etc.) are frayed or damaged when exiting the printer, then the media guide stop position may need further adjustment. If this does not correct the problem, then the media can be routed over the two roll holding pins on the media guide. An empty roll core of the same width as the stack of the fan-fold media can be placed between the roll holders to provide additional support for thin media.

Printing with Externally Mounted Roll Media

The printer accommodates externally mounted roll media similar to the printer's support of fan-fold media. The printer requires the media roll and stand combination to have a low initial inertia to pull the media off the roll.

Externally Mounted Roll Media Considerations:

- The media ideally should enter the printer directly behind the printer through the fan-fold media slot in the rear of the printer. Go to [Printing on Fan-Fold Media on page 210](#) for media loading.
- Lower the print speed to decrease the chance of motor stalls. The roll typically has the highest inertia when trying to start the roll moving. Larger media roll diameters require the printer to have more torque applied to get the roll moving.
- The media should move smoothly and freely. The media should not slip, skip, jerk, bind and then move, etc. when mounted on your media stand.

- The printer should not touch the media roll.
- The printer should not slip or lift up off the operating surface.

Using the Label Dispenser Option

The label dispenser option allows you to print a label and have the backing material (liner/web) automatically removed. When printing multiple labels, removing the dispensed (peeled) label triggers the printer to print and dispense the next label.

To use dispense-mode, set 'Media Handling' to 'Peel-Off' in the printer driver or with the Zebra Setup Utility using the 'Configure Printer Settings' wizard. Otherwise, you must send the ZPL programming commands to the printer.

When programming in ZPL, you can use the command sequences shown below to configure the printer to use the dispenser option:

```
^XA ^MMP ^XZ  
^XA ^JUS ^XZ
```

1. Load your labels into the printer. Close the printer and press the FEED button until a minimum of 100 millimeters or 4 inches of exposed labels exit the printer. You can leave the labels on the liner.



2. Lift the liner over the top of the printer. Pull the gold latch in the center of dispenser door away from the printer and the door will open.



3. Insert the label liner between the dispenser door and the printer body.



4. Close the dispenser door while pulling the end of the label liner tight.



5. Press and release the FEED (Advance) button one or more times until a label gets presented for removal.



6. During the print job, the printer will peel off the backing and present a single label. Take the label from the printer to allow the printer to print the next label.



NOTE: If you did not activate the label taken sensor to detect the removal of the dispensed (peeled) label with software commands, the printed labels will stack and may bind the mechanism.

Using the Linerless Options

The Linerless Media Tear-Off and Cutter options operate like the standard media printers. These options include an additional sensor to detect when a printed and presented label is taken from the printer.

Linerless printers require special cleaning processes to maximize the platen (drive) roller and special non-stick surfaces in the printer and media path areas.

the Linerless printing option allows you to print a multi-label format/form that stops between each label. Removing the dispensed (peeled) label triggers the printer to print and dispense the next label until all labels have been printed.

To use dispense-mode, set 'Media Handling' to 'Peel-Off' in the printer driver or with the Zebra Setup Utility using the 'Configure Printer Settings' wizard. Otherwise, you must send the ZPL programming commands to the printer.

When programming in ZPL, you can use the command sequences shown below to configure the printer to use the dispenser option:

```
^XA ^MMP ^XZ  
^XA ^JUS ^XZ
```

Linerless Printing

- Linerless media loads the same as models with the standard 'tear-off' bezel or the general cutter factory options. Go to [Loading Roll Media on page 158](#).
- **Media Reloading** - Clean the printhead and inspect the media path and platen roller for build up of adhesive and debris. Remove particles with the adhesive side of your linerless media. Lightly touch the media path and platen roller with the label to lift particles off the exposed area of the platen roller and the media path areas. Go to [Linerless Platen \(Drive\) Roller on page 241](#) cleaning procedure.
- **Don't remove new media from it's protective wrapping** until you are ready to place it in the printer. Setting the roll on its side will pick up contaminants and may stick to surfaces.



IMPORTANT: The platen roller can accumulate adhesive on the outer edges of the roller. After using many rolls of media, these 'rings' of adhesive can get dislodged when using printer. These particle clumps can then get transferred to other areas.

Sending Files to the Printer

Graphics, fonts and programming files can be sent to the printer from the Microsoft Windows operating systems by using the Link-OS Profile Manager, Zebra Setup Utilities (and driver), ZebraNet™ Bridge or Zebra® ZDownloader found on the Zebra Web site: zebra.com/software.

Ribbon Cartridge Programming Commands

The ZD421 Ribbon Cartridge printer offers several Set Get Do (SGD) programming commands to support the use of the ribbon cartridge. Refer to the ZPL Programmer's Guide for more details on SGD commands and SGD "ribbon" commands in particular. The following are examples of SGD ribbon cartridge commands.

```
! U1 getvar "device.feature.ribbon_cartridge"
! U1 getvar "ribbon.cartridge.part_number"
! U1 getvar "ribbon.cartridge.authenticated"
! U1 getvar "ribbon.cartridge.length_remaining"
! U1 getvar "ribbon.cartridge.serial_number"
! U1 getvar "ribbon.cartridge.width"
! U1 getvar "ribbon.cartridge.type"
! U1 getvar "ribbon.cartridge.length"
! U1 getvar "ribbon.cartridge.inserted"
```

ribbon.ribbon_low.warning : 50 , Choices: off,5,10,15,25,50,75,100

```
! U1 getvar "ribbon"
! U1 getvar "ribbon.ribbon_low.warning"
! U1 setvar "ribbon.ribbon_low.warning" "75"
! U1 setvar "ribbon.ribbon_low.warning" "off"
```

The Zebra Setup Utilities may be used to send commands and receive status back from the printer using the 'Open Communication With Printer' feature.

Printing with the Attached Battery Base and Battery Option

Printer operating procedures change slightly when using the battery. Power connections and power loss scenarios require differences in operation. The battery is designed to maximize battery life, maintain print quality, and have simple operation.

- Connecting the printer's external power supply to the battery will wake up the battery. The battery determines if charging is needed.
- The battery will not start charging until the battery's charge level is below 90% charge. This extends your battery's life.
- Once charging has begun, the battery will charge to 100% capacity and then go into Sleep Mode.
- The printer is receiving the external power passed through by the battery circuitry into the printer. The battery does not charge while printing or moving media.
- The battery uses very small amount of power during Sleep Mode to maximize the available charge stored in the battery.
- It takes about 2 hours to charge a fully discharged battery.

UPS Mode

The printer is receiving the external power passed through by the battery circuitry into the printer.

1. Press the Battery Control Button to 'wake up' the battery and check the battery has charge. After 60 seconds the battery "goes to sleep".
2. The battery is in Sleep Mode awaiting the loss of external power to the battery (and attached printer).

The printer can be turned OFF and ON normally and does not require the battery be turned on to operate.

Battery Mode

The printer is powered by the battery only.

1. Press the Battery Control Button to 'wake up' the battery and check the battery has charge. After 60 seconds the battery "goes to sleep" if the printer has not been turned on yet.
2. Turn the printer ON.
3. Use the printer normally.
4. Check the battery charge status at any time by pressing the Battery Control Button.
5. Change or charge your battery when the last battery charge level indicator is flashing. Your print operation may be interrupted if the battery charge is used up and the printer turns off.

Printer Fonts

The ZD-Series printer supports your language and font requirements. The ZPL™ programming language provides advanced font mapping and scaling technology to support outline fonts (TrueType™ or OpenType™) and Unicode character mapping as well as basic bitmapped fonts and character code pages.

The printer's font capabilities are programming language dependent. The ZPL and the legacy EPL programming guides describe and document the fonts, code pages, character access, listing fonts, and limitations for their respective printer programming languages. Refer to the printer programming guides for information on Text, Fonts and Character support.

Zebra has variety of utilities and application software that support font download to the printer for ZPL and EPL printer programming languages.



IMPORTANT: Some factory installed ZPL fonts in your printer cannot be copied, cloned or restored to your printer by reloading or updating firmware. If these license restricted ZPL fonts are removed by an explicit ZPL object delete command, they must be repurchased and reinstalled via a font activation and installation utility. EPL fonts do not have this restriction.

Identifying Fonts in Your Printer

Fonts and memory are shared by the programming languages in the printer. Fonts can be loaded into various storage locations in the printer. ZPL programming can recognize EPL and ZPL fonts. EPL programming can only recognize EPL fonts. Refer to the respective programmer guides for more information on fonts and printer memory.

ZPL Fonts

- To manage and download fonts for ZPL print operation, use the Zebra Setup Utility or ZebraNet™ Bridge.
- To display all of the fonts loaded in your printer, send the printer the ZPL command `^WD`. Refer to the ZPL Programmers Guide for details.
 - Bitmap fonts in the various printer memory areas are identified by the `.FNT` file extension in ZPL.
 - Scalable fonts are identified with the `.TTF`, `.TTE` or `.OTF` file extensions in ZPL. EPL does not support these fonts.

Localizing the Printer with Code Pages

The Link-OS 4 inch Desktop printer supports two sets of language, region and character sets for permanent fonts loaded into the printer for each printer programming language, ZPL and EPL. The printer supports localization with common international character map code pages.

- For ZPL code page support, including Unicode, refer to the `^CI` command in the ZPL programmer's guide.

Asian fonts and Other Large Font Sets

Asian language ideographic and pictographic fonts have large character sets with thousands of characters that support single language code page. In order to support the large Asian character sets, the industry adopted a double-byte (67840 maximum) character system instead of the single-byte characters (256 maximum) used by Latin based language characters to address large font sets. In order to address multiple languages with a single font set, Unicode was invented. A Unicode font supports one or more code points (relate these to code page character maps) and is accessed in a standard method that resolves character mapping conflicts. The ZPL programming language supports Unicode. Both of the printer's programming languages support the large pictographic double-byte character Asian font sets.

The number of fonts that can be downloaded is dependent upon the amount of available flash memory not already in use and the size of the font to be downloaded.

Some Unicode fonts are large such as MS (Microsoft) Arial Unicode font (23 MB) available from Microsoft or the Andale font (22 MB) offered by Zebra. These large font sets typically support a large number of languages as well.

Getting Asian Fonts

Asian bitmap font sets are downloaded into the printer by the user or integrator. The ZPL fonts are purchased separately from the printer. EPL Asian Fonts are available for free to download from the Zebra Web site.

- Simplified and Traditional Chinese
(The SimSun scalable font is pre-loaded onto printers sold with a Chinese power cord.)
- Japanese — JIS and Shift-JIS mappings
- Korean including Johab
- Thai

EPL Line Mode - Direct Thermal Printers only

Your direct thermal printer supports Line Mode printing. EPL Line Mode printing is designed to be command compatible with EPL1 programming language used in early model LP2022 and LP2042 printers. The Zebra 2800 series direct thermal printers also included Line Mode printer language support. The Link-OS 4 inch Desktop continues Zebra's support of Line Mode.

Line mode printing is ideal for basic retail (point of sale - POS), shipping, inventory, work flow control, and general labeling. EPL printers with Line Mode, are versatile and are capable of printing a wide range media and bar codes.

Line Mode printing only prints single lines the height of the largest element present in the line of text and data - bar code, text, a logo or simple vertical lines. Line mode has many limitations due to the single line of print: no fine element placement, no overlapping elements, and no horizontal (ladder) bar codes.

- Line Mode printer operation is entered by sending the printer the EPL **OEPL1** command. Refer to the EPL Programmers Guide (Page Mode) or the EPL Line Mode Programmers Guide.
- Line Mode printer operation is exited by sending the printer the **escOEPL2** Line Mode command. Refer to the EPL Line Mode Programmers Guide.
- With Line Mode active, ZPL and EPL (EPL2) Page Mode programming will be processed as Line Mode programming and data.
- With the default ZPL and EPL (EPL2) Page Mode active, Line Mode programming will be processed as ZPL and/or EPL programming and data.
- Verify printer programming modes by printing out a printer configuration.

ZD621 and ZD421 Locking Printer Option

The Locking Printer option is available as a Healthcare printer only. The Locking Printer's features are:

- Lock and key access to the printer's media compartment.
 - Metal locking mechanism built into the printer.
 - Precision fabricated metal parts for repeatable movement.
 - Locking mechanism comes with two-keys.
- Supports industry recognized Kensington lock slot that allows you to lock printer to any immovable object such as a desk.
- Permanently sealed media window for added security (not serviceable).
- The FEED button is disabled to prevent user from manually advancing media while the media compartment is locked. The FEED key will always boot up in FEED disabled mode.
- Supports all media that is contained within the printer. Not recommend for fan-fold media.

For an illustration of the Locking Printer's features, go to [ZD621 Direct Thermal Locking Printer Features on page 35](#).

Zebra® ZKDU — Printer Accessory

The Zebra® ZKDU (keyboard display unit) is a small terminal unit that interfaces with the printer for accessing EPL or ZPL label forms stored in the printer.

The ZKDU is strictly a terminal and does not have the capability to store data or set up parameters.

The ZKDU is used for the following functions:

- List label forms stored in printer
- Retrieve label forms stored in printer
- Input variable data
- Printing labels
- Switching between EPL and ZPL to dual support both printer language format/form types that can be stored and printed in many later model Zebra label printers.

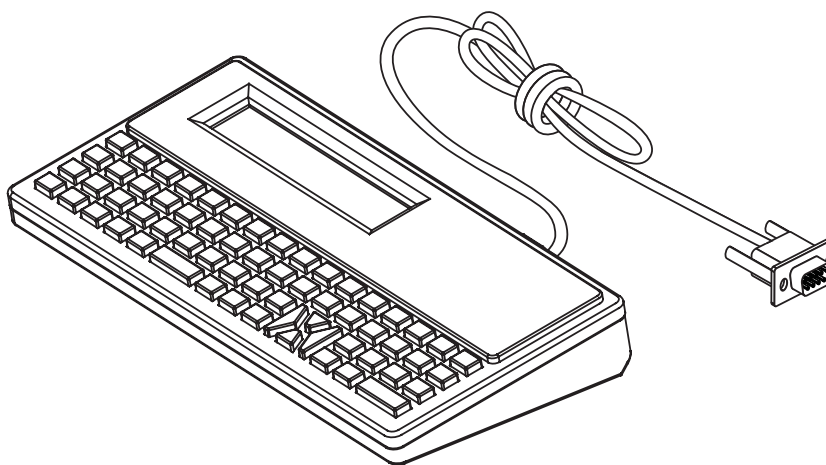

ZBI 2.0™ — Zebra Basic Interpreter

Customize and enhance your printer using the ZBI 2.0™ programming language. ZBI 2.0 allows Zebra printers to run applications and take input from scales, scanners and other peripherals without a PC or network connection. ZBI 2.0 works with the ZPL printer command language so that printers can understand non-ZPL data streams and convert them into labels. That means the Zebra printer can create barcodes and text from input received, non-ZPL label formats, sensors, keyboards and peripherals. Printers can also be programmed to interact with PC based database applications to retrieve information to be used on printed labels.

- ZBI 2.0 can be activated by ordering a ZBI 2.0 Key Kit, or activated by purchasing a key from Zebra.
- Use the ZBI Key Manager (also know as ZDownloader utility) to apply the key.
- An intuitive ZBI-Developer™ is used to create, test and distribute ZBI 2.0 applications. The built-in "Virtual Printer" allows you to quickly create, test and prepare programs for use. ZBI-Developer is available at the Zebra Web site:

Refer to the Zebra Web site for Zebra Basic Interpreter 2.0 at zebra.com/software

Setting the Power Failure Recovery Mode Jumper

The printer can be configured to re-start itself after a power failure, unattended, with Power Failure Recovery Mode.



NOTE: The Power Failure Recovery Mode is only available on printers with a Printer Connectivity Module installed in your printer.

The Printer Connectivity Modules have a Power Failure Recovery jumper set to OFF. With the jumper set to ON, the printer will automatically Power ON when plugged into an active (ON) AC power source (and not power off).



CAUTION—ESD: The discharge of electrostatic energy that accumulates on the surface of the human body or other surfaces can damage or destroy the printhead or electronic components used in this device. You must observe static-safe procedures when working with the printhead or the electronic components.

Setting the Jumper

1. Disconnect the DC power plug and any interface connectors from the rear of the printer.
2. Remove the module access door and connectivity module. Go to [Removing Printer Connectivity Modules on page 52](#) for instructions for ZD421 printer models. The connectivity module on a ZD621 printer model is removed like a ZD421 printer's module.
3. Move the AUTO (Power Failure Recovery Mode) jumper from the OFF position to the ON.
4. Reinstall the connectivity module and module access door. Go to [Installing the Internal Ethernet \(LAN\) Module on page 51](#) or [Installing the Serial Port Module on page 50](#) for ZD421 printer models. The connectivity module on a ZD621 printer model is installed like a ZD421 printer's module.
5. Reconnect the printer DC power plug and interface cables to the printer.

USB Host Port and Link-OS Usage Examples

This section has information on using the printer's USB Host port along with Link-OS features and Apps (applications).

USB Host

The USB host port allows you to connect USB devices — such as a keyboard, scanner, or USB Flash (memory) drive — to the printer.

USB Host Port Uses

- Firmware updates
- File transfers and management
- A port for low power USB data entry devices (keyboards, scales, scanners, and other wedge devices).

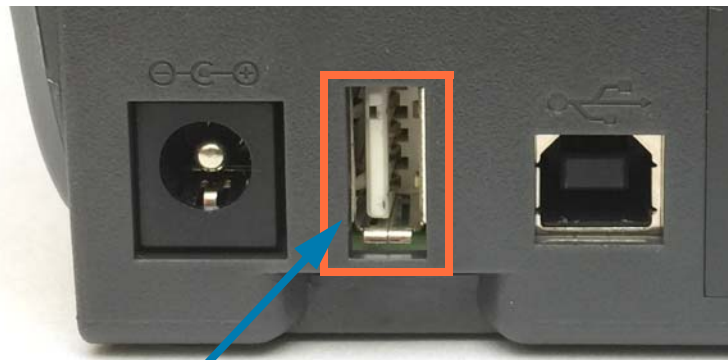

USB Host Port



IMPORTANT: The USB Flash drive must be formatted with the FAT file system. Filenames may be 1 to 16 alphanumeric characters (A, a, B, b, C, c, ..., 0, 1, 2, 3, ...) only. Only use ASCII characters. Do not use Asian characters, Cyrillic characters, or accented characters in file names. Some functions may not work properly if there are underscores in a file name. Use periods instead.

Using USB Host for Firmware Updates

The USB host port allows you to connect an USB Flash drive to the printer to perform firmware updates.

This is an example of using the powerful printer management, Zebra Mirror functions. Refer to the ZPL Programming Guide — **Mirror** and **Set-Get-Do** (SGD) `usb.mirror` commands operation.



NOTE: Go to [About on page 11](#) for information and support links for your specific printer model.



IMPORTANT: Supports USB Flash drives (or “thumb drive” or “memory stick”) up to 1 Terabyte (TB). The printer will not recognize drives larger than 1 TB.

Flash Drive Preparation and Firmware Update

1. On your USB Flash Drive, create the following:

- a folder called Zebra
- in that folder, create three sub-directories:
 - appl
 - commands
 - files

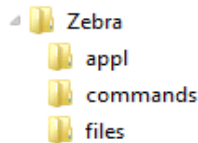

2. In the `/appl` folder, place a copy of the latest firmware for your printer.

3. Load the printer with media. Go to [Loading Roll Media on page 158](#).

4. Insert the USB Flash drive into the USB host port on your printer.

5. Observe the user interface and wait.

If the firmware version on the USB Flash drive is different than the version installed on the printer, the firmware will download to the printer. The data indicator will flash green while the firmware is downloading. The printer will restart with all indicators flashing. When the firmware update has completed, the STATUS indicator will display solid Green as the firmware is validated and installed. The ZD621 printer with a Color Touch Display will display firmware download status messages on the screen (and the screen shows the firmware version). A printer Configuration Report is automatically printed and the firmware update has been completed.

6. Remove the USB Flash drive from the printer.

USB Host and Printer Usage Examples

The exercises in this section will teach you how to perform USB mirror (using an alternate firmware update procedure), how to transfer files to and from the printer, and how to provide information for which you are prompted and then print a label using that information.

Items Required for the USB Host Exercises

To perform the exercises in this document, you will need the following:

- USB Flash drive up to 1 Terabyte (TB). The printer will not recognize drives larger than 1 TB.
- USB keyboard.
- Various files referenced below (from files attached inside this PDF file)
- Free Zebra Utilities app for your smart phone (search for Zebra Tech in the Google Play store).

Files for Completing the Exercises

These exercises demonstrate common practice of manually updating printers the latest firmware and a label format. Copy these files to your computer before you begin the exercises from the printer's support page. Where possible, the contents of the files are shown. The contents of files that contain coded content, which cannot be viewed as text or as an image, are not included.

File 1: ZEBRA.BMP



File 2: SAMPLELABEL.TXT

```
^XA
^F0100,75^XGE:zebra.bmp^FS
^F0100,475^A0N,50,50^FDMirror from USB Completed^FS
^XZ
```

This simple label format prints the Zebra logo and a line of text at the end of the mirroring exercise.

File 3: LOGO.ZPL

Uses the Zebra logo bitmap file.

File 4: USBSTOREDFILE.ZPL

```

CT~~CD,~CC^~CT~
^XA~TA012~JSN^LT0^LH0,0^JMA^PR4,4~SD15^LRN^CI0^XZ
~DG000.GRF,07680,024,,[image data]
^XA
^LS0
^SL0
^BY3,3,91^FT35,250^BCN,,Y,N^FC%,{,#{^FD%d/%m/%Y^FS
^FT608,325^XG000.GRF,1,1^FS
^FT26,75^A0N,28,28^FH\^FDThis label was printed from a format stored^FS
^FT26,125^A0N,28,28^FH\^FDOn a USB Flash Memory drive. ^FS
^BY3,3,90^FT33,425^BCN,,Y,N
^FD>:Zebra Technologies^FS
^PQ1,0,1,Y^XZ
^XA^ID000.GRF^FS^XZ
    
```

This label format prints an image and text. This file will be stored on the USB memory device at the root level so that it can be printed.

File 5: VLS_BONKGRF.ZPL

File 6: VLS_EIFFEL.ZPL

File 7: KEYBOARDINPUT.ZPL

```

^XA
^CI28
^BY2,3,91^FT38,184^BCN,,Y,N^FC%,{,#{^FD%d/%m/%Y^FS
^F0385,75^XGE:zebra.bmp^FS
^FT40,70^A0N,28,28^FH\^FDThis label was printed using a keyboard input.
^FS
^FT35,260^A0N,28,28^FH\^FDThis label was printed by:^FS
^FT33,319^A0N,28,28^FN1"Enter Name"^FS
^XZ
    
```

This label format, used for the USB keyboard input exercise, does the following:

- Creates a barcode with the current date, based on your Real-Time Clock (RTC) setting. (RTC may not be present in the printer version you purchased)
- Prints the Zebra logo graphic
- Prints fixed text
- Prints text entered with the keyboard by a operator

File 8: SMARTDEVINPUT.ZPL

```

^XA
^CI28
^BY2,3,91^FT38,184^BCN,,Y,N^FC%,{,#{^FD%d/%m/%Y^FS
^F0385,75^XGE:zebra.bmp^FS
^FT40,70^A0N,28,28^FH\^FDThis label was printed using a smart device input. ^FS
^FT35,260^A0N,28,28^FH\^FDThis label was printed by:^FS
^FT33,319^A0N,28,28^FN1"Enter Name"^FS^XZ
    
```

The same label format as the previous label, only with different text printing. This format is used for the smart device input exercise.

Exercise 1: Copy Files to a USB Flash Drive and Perform USB Mirror

1. On your USB Flash Drive, create the following:

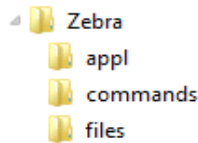

- a folder called **Zebra**
 - in that folder, three sub folders:
 - **appl**
 - **commands**
 - **files**
2. In the **/appl** folder, place a copy of the latest firmware for your printer.



NOTE: Some functions may not work properly if there are underscores in a file name. Use periods instead.

2. In the **/files** folder, place the following file:
 - **File 1: ZEBRA.BMP**
3. In the **/commands** folder, place the following files:
 - **File 2: SAMPLELABEL.TXT**
 - **File 3: LOGO.ZPL**
4. Insert the USB Flash drive into a USB host port on the front of your printer.
5. Observe the user interface and wait. The following should happen:
 - If the firmware on the USB Flash drive is different than what is on the printer, the firmware downloads to the printer. The printer then restarts and prints a printer configuration label. (If there is no firmware on the USB Flash drive or if the firmware version is the same, the printer skips this action.)
 - The printer downloads the files in the **/files** folder and briefly shows the names of the files that are downloading on the display.
 - The printer executes any files in the **/commands** folder.
 - The printer restarts and then displays the message **MIRROR PROCESSING FINISHED.**
6. Remove the USB Flash drive from the printer.

Exercise 1: Advanced User Information

Refer to the ZPL Programming Guide for more information about these commands.

Enable/disable mirroring:

! U1 setvar "usb.mirror.enable" "value" – **Values:** "on" or "off"

Enable/disable automatic mirroring that occurs when a USB Flash drive is inserted into the USB host port:

! U1 setvar "usb.mirror.auto" "value" – **Values:** "on" or "off"

Mirror Operation Retry Number — Specify the number of times that the mirror operation will be repeated if it fails:

! U1 setvar "usb.mirror.error_retry" "value" – **Values:** 0 to 65535

Change File Path FROM USB — Reprogram the file location the printer searches to retrieve files from the USB memory during Mirror operations.

! U1 setvar "usb.mirror.appl_path" "new_path" – **Default:** "zebra/appl"

Change File Path TO USB — Reprogram the file location the printer places files into USB memory during Mirror operations.

! U1 setvar "usb.mirror.path" "path" – **Default:** "zebra"

Enable/disable the USB Host port

! U1 setvar "usb.host.lock_out" "value" – **Values:** "on" or "off"

Exercise 2: Print a Label Format from a USB Flash Drive

The Print USB File option allows you to print files from a USB mass storage device, such as a USB Flash drive. Only printable files (.ZPL and .XML) may be printed from the USB mass storage device, and the files must be located at the root level, not in a directory.

1. Copy the following files to your USB Flash drive:
 - [File 4: USBSTOREDFILE.ZPL](#)
 - [File 5: VLS_BONKGRF.ZPL](#)
 - [File 6: VLS_EIFFEL.ZPL](#)
2. Insert the USB Flash drive into a USB host port on the front of your printer.
3. From the printer's display, touch the **Menu > Storage** on the printer's Home screen.

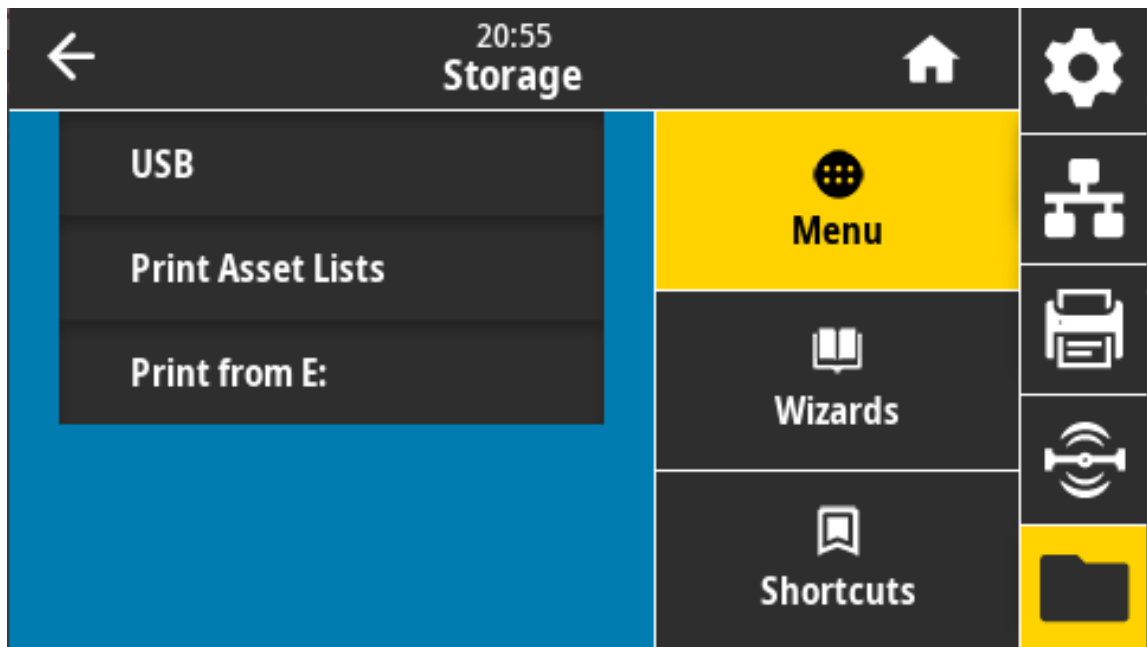

6. Touch and select **Menu > Storage > USB > Print: From USB**. The printer lists available files.

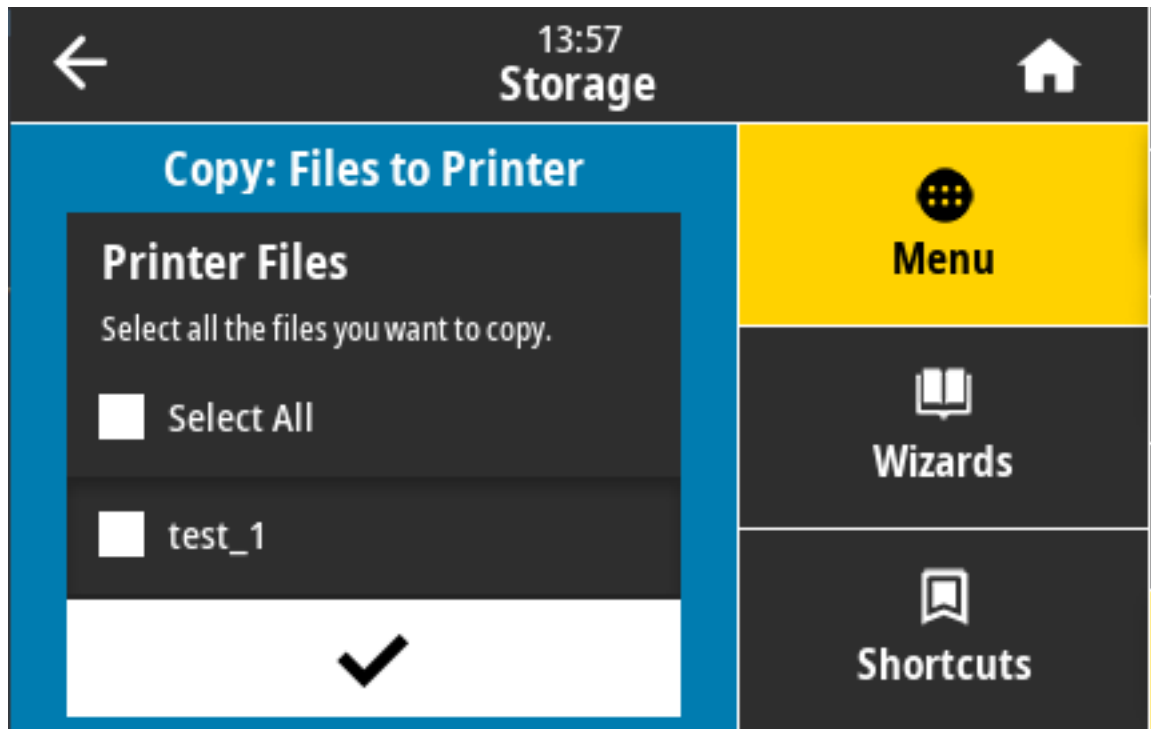

7. Touch the box next to the desired files. **Select All** is also available.
8. Touch the checkmark to print the selected files.
9. Remove the USB Flash drive from the printer.

Exercise 3: Copy Files to/from a USB Flash Drive

The Copy USB File option allows you to copy files from a USB mass storage device to the printer's Flash memory E: drive.

1. Copy the following files to the root directory of your USB Flash drive. Do not put these files into a sub-folder.
 - [File 7: KEYBOARDINPUT.ZPL](#)
 - [File 8: SMARTDEVINPUT.ZPL](#)
2. Insert the USB Flash drive into a USB host port on the front of your printer.
3. From the printer's display, touch the **Menu** on the printer's **Home** screen.

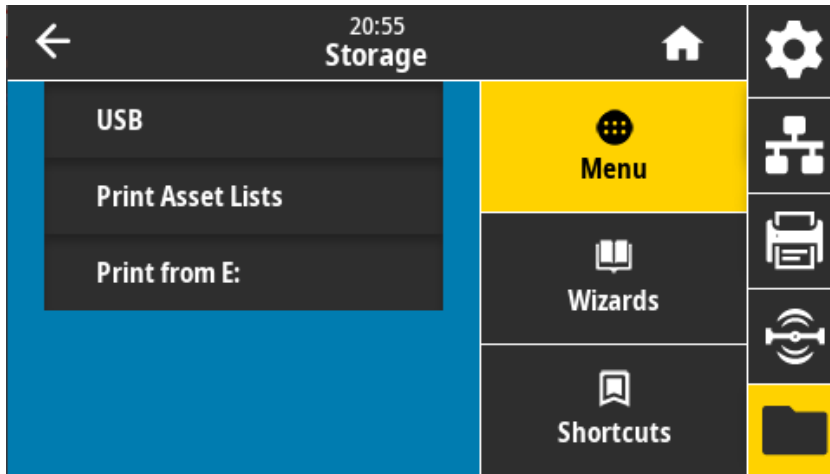

4. Touch **Menu** > **Storage** > **USB** > **Copy: Files to Printer**. The printer lists available.

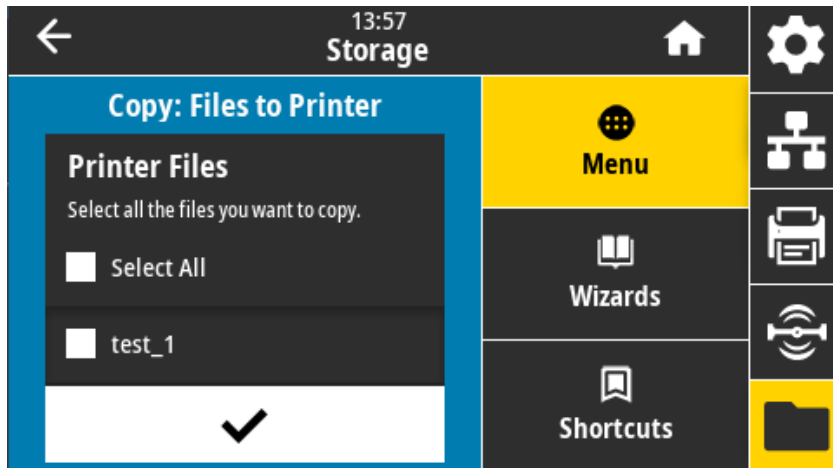

5. Touch the box next to the desired files. **Select All** is also available.
 6. Touch the checkmark to copy the selected files.
 7. Remove the USB Flash drive from the printer.
- The printer stores the file in E: memory.

8. You can now copy files from the printer to a USB Flash drive using the **Menu > Storage > USB > Copy: Files to USB**.

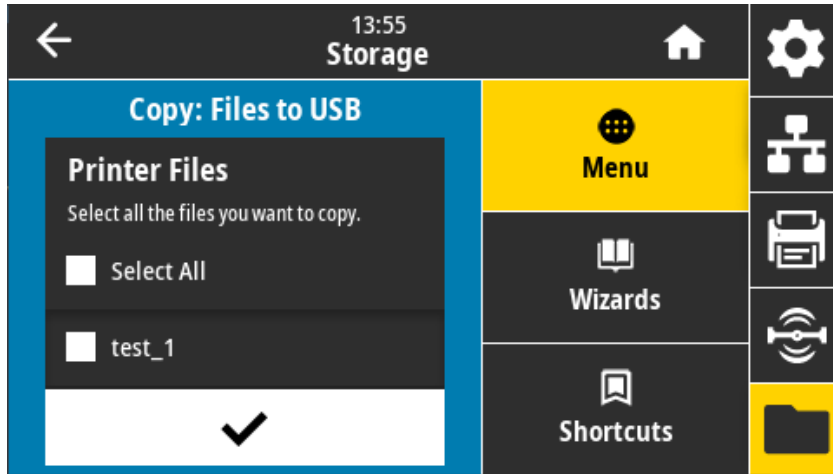

The option **SELECT ALL** is available to store all of the available files from the printer to the USB Flash drive. Any **.ZPL** file that is copied will be post-processed such that the contents of the file will be suitable to be sent to a printer for normal execution.

Exercise 4: Enter Data for a Stored File with a USB Keyboard and Print a Label

The Print Station feature allows you to use a USB Human Interface Device (HID), such as a keyboard or a barcode scanner, to enter ^FN field data into a *.ZPL template file.

1. After performing the previous exercise, plug a USB keyboard into a USB host port.
2. Touch **Menu > Print**.

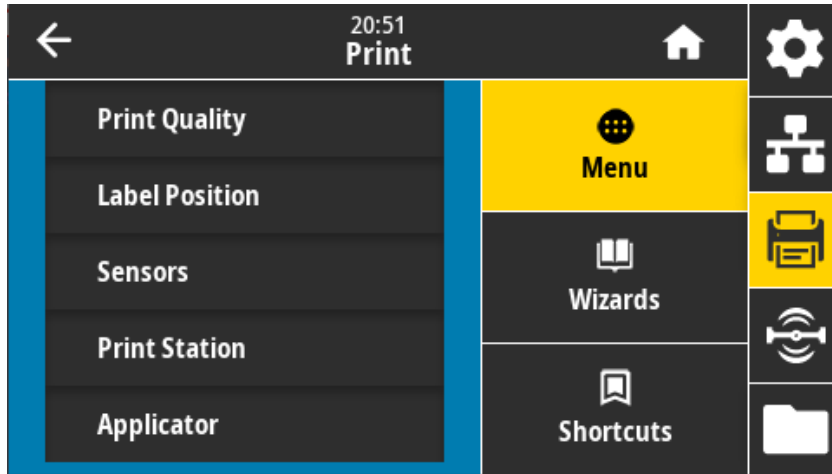

3. Touch **Menu > Print > Print Station**. The printer loads any executable files and processes them. The available files are listed.

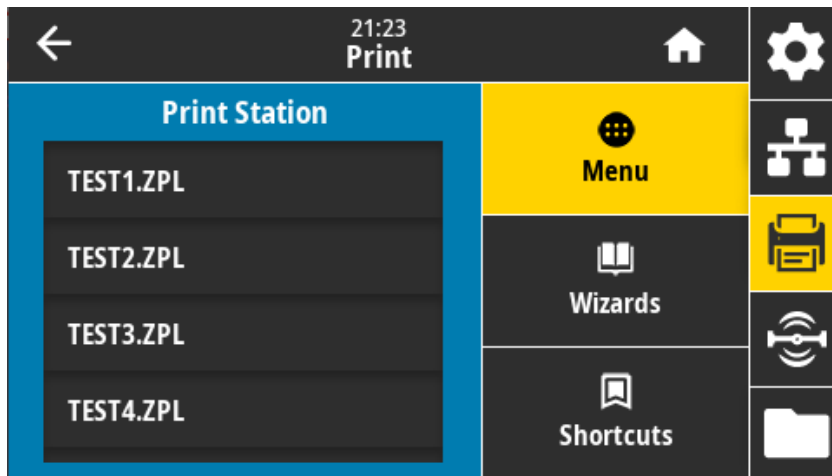

4. Select the file **KEYBOARDINPUT.ZPL**.
5. The printer accesses the file and prompts you for the information in the ^FN fields in the file. In this case, it prompts you for your name.
6. Type your name, and then press <ENTER>. The printer prompts for the number of labels to print.
7. Specify the desired quantity of labels, and then press <ENTER> again.

The specified number of labels is printed, with your name in the appropriate fields.

Using the USB Hosts Port and the NFC Capabilities

The Zebra Print Touch™ feature allows you to touch an Android™ -based, Near Field Communication (NFC)-enabled device such as a smart phone or tablet to the printer's Print Touch logo to pair the device to the printer. This capability allows you to use your device to provide information for which you are prompted and then print a label using that information.



IMPORTANT: Some mobile devices may not support NFC communication with the printer until you configure the required NFC settings in your device. If you encounter difficulties, consult your service provider or your smart device manufacturer for more information.



Exercise 5: Enter Data for a Stored File with a Smart Device and Print a Label



NOTE: The steps in this exercise may vary somewhat based on your smart device, on your service provider, or on whether you already have the free Zebra Utilities app installed on your smart device.

Refer to the Zebra Bluetooth User Guide for specific instructions for configuring your printer to use a Bluetooth interface. A copy of this manual is available at: zebra.com/manuals.

1. If you do not have the Zebra Utilities app installed on your device, go to the app store for your device, search for the Zebra Utilities app, and install it.
2. Pair your smart device with the printer by holding the smart device next to the Zebra Print Touch icon on the printer.
 1. If necessary, access the Bluetooth information about your printer using your smart device. For instructions, refer to the manufacturer's documentation for your device.
 - a. If necessary, select the Zebra printer's serial number to pair it with the device.
 - b. After your smart device has been detected by the printer, the printer may prompt you to accept or reject the pairing. If necessary, press the LEFT SELECT button on the printer to select ACCEPT. Some smart devices will pair with the printer without this prompt.
3. Start the Zebra Utilities App on your device. The Zebra Utilities main menu displays.



4. Perform these steps if you have an Apple device:
 - a. Tap the Settings icon (gear) in the lower-right corner.
 - b. Change the setting for **Get Labels From Printer** to **ON**.
 - c. Tap Done.
 - d. Tap Files.

The smart device gets data from the printer and displays it.



NOTE: This retrieval process may take a minute or more to complete.

5. Scroll through the formats shown and select **E : SMARTDEVINPUT . ZPL**.

Based on the ^FN field in the label format, the smart device prompts you for your name.

6. Enter your name at the prompt.
7. Change the quantity of labels to print, if desired.
8. Tap PRINT to print the label.

Maintenance

This section provides routine cleaning and maintenance procedures.

Cleaning

Your Zebra printer may require periodic maintenance to keep your printer functional and printing high quality labels, receipts, tags, etc.

Cleaning Supplies

The following printer cleaning supplies are recommended for use with your printer:

- **Printhead Cleaning Pens** for simple operator printhead cleaning.
- **99.7% pure Isopropyl Alcohol** (Use a labeled dispenser. Never re-moisten cleaning materials used to clean the printer).
- **Fiber-free Cleaning Swabs** for media path, guides, and sensors **and Cleaning Wipes** for media path and interior (for example Kimberly-Clark Kimwipes).
- **Can of Compressed Air.**



IMPORTANT: The cutter mechanism does not require maintenance cleaning. **DO NOT** clean the blade or mechanism. The blade has a special coating to resist adhesives and wear.



IMPORTANT: Using too much alcohol can result in contamination of the electronic components requiring a much longer drying time before the printer will function properly.



IMPORTANT: Do Not Use an air compressor in place of the can of compressed air. Air compressors have micro contaminants and particles that get into the air system and damage your printer.



CAUTION—EYE INJURY: Use eye protection to protect your eyes from flying particles and objects when using compressed air.

Get Zebra Supplies and Accessories for Cleaning Your Printer

Go to the Zebra Web site: zebra.com/accessories

Recommended Cleaning Schedule

Printhead

Interval: Clean the printhead after every 5 rolls printed.

Procedure: [Cleaning the Printhead on page 243](#)

Standard Platen (Drive) Roller

Interval: As needed to improve print quality. Platen rollers can slip causing print image distortion and in worst case scenarios not move the media (labels, receipts, tags, etc.).

Procedure: Go to [Platen Cleaning and Replacement on page 255](#).



NOTE: Standard platen rollers come in two colors, black (203 dpi) and gray (300 dpi).

Linerless Platen (Drive) Roller

Interval: If there is observed build-up of particles on the platen roller, use this procedure. The linerless platen normally does not require cleaning. The adhesive side of the media picks up particles as you print.

If the linerless media is sticking and binding in the printer, the linerless platen normally needs to be replaced. The silicon non-stick coating has been used up.



IMPORTANT: Linerless platen rollers come in two colors, reddish-brown (203 dpi) and brown (300 dpi).



IMPORTANT: Cleaning the roller with solutions or rubbing the delicate surface of this type of roller will permanently damage or shorten the usable life of the linerless platen.



IMPORTANT: The platen roller can accumulate adhesive on the outer edges of the roller. After using many rolls of media, these 'rings' of adhesive can get dislodged when using the printer. These particle clumps can then get transferred to other areas in the printer, most importantly, the printhead.

Procedure: To remove adhesive particles, use the adhesive side of a piece of linerless media to gently press and remove the particles from the platen roller. Use the [Platen Cleaning and Replacement on page 255](#) procedure to get better access for particle removal.

Media Path

Interval: Clean as needed.

Method: Clean it thoroughly with fiber-free cleaning swabs and cloths moistened with 90% isopropyl alcohol. Let alcohol evaporate completely.

Procedure: Go to [Media Path Cleaning on page 246](#).

Interior

Interval: Clean the printer as needed.

Method: Use a soft cloth, brush or compressed air to wipe or blow dust and particles out of the printer. Use 90% isopropyl alcohol and a fiber-free cleaning cloth to dissolve contaminants like oils and grime.

Exterior

Interval: Clean as needed.

Method: Use a soft cloth, brush or compressed air to wipe or blow dust and particles out of the printer. The exterior of the printer can be cleaned using plain soap and water solutions to moisten the cloth. Only use the minimum amount of cleaning solution to avoid getting solution in the printer or other areas. Do not clean connectors or interior of the printer with this method.

Healthcare Printer Models — The latest models now include Ultra-Violet (UV) and disinfectant-ready plastics for hospital and other similar environments. The user control's are sealed so they can be cleaned with the rest of the printer's exterior. Refer to the '**Guide To Disinfecting and Cleaning Zebra® Healthcare Printers**' on the Zebra Web site for the latest information on tested and approved cleaning materials, and cleaning methods.

Label Dispenser Option

Interval: As needed to improve label dispensing operations.

Procedure: Go to [Label Dispenser Option on page 242](#) cleaning.

Cutter Option

Interval: Not an operator serviceable component. Do Not Clean inside the cutter opening or blade mechanism. You may use the Exterior cleaning to clean the cutter bezel (housing).

Method: Call a service technician.

Procedure: Not applicable.



CAUTION: There are no operator serviceable parts in the cutter unit. Never remove the cutter cover (bezel). Never attempt to insert objects or fingers in to the cutter mechanism.



IMPORTANT: The blade has a special coating to resist adhesives and wear. Cleaning it may ruin the blade.



IMPORTANT: Using un-approved tools, cotton swabs, solvents (including alcohol), etc.; all may damage or shorten the cutter's usable life or cause the cutter to bind.

Cleaning the Printhead

Always use a new cleaning pen on the printhead (an old pen carries contaminants from its previous use that may damage the printhead).

When you load new media, you should clean the printhead for optimal print operations.



CAUTION—HOT SURFACE: The printhead becomes hot while printing. To protect from damaging the printhead and risk of personal injury, avoid touching the printhead. Only use the cleaning pen to perform printhead maintenance.



CAUTION—ESD: The discharge of electrostatic energy that accumulates on the surface of the human body or other surfaces can damage or destroy the printhead and other electronic components used in this device. You must observe static-safe procedures when working with the printhead or the electronic components under the top cover.

ZD621 / ZD421 Direct Thermal Printers

When you load new media, you can also clean the printhead.

1. Rub the cleaning pen across the dark area of the printhead. Clean from the middle to the outside. This will move adhesive transferred from the edges of media to the outside of media path.
2. Wait one minute before closing the printer to allow the components to dry.

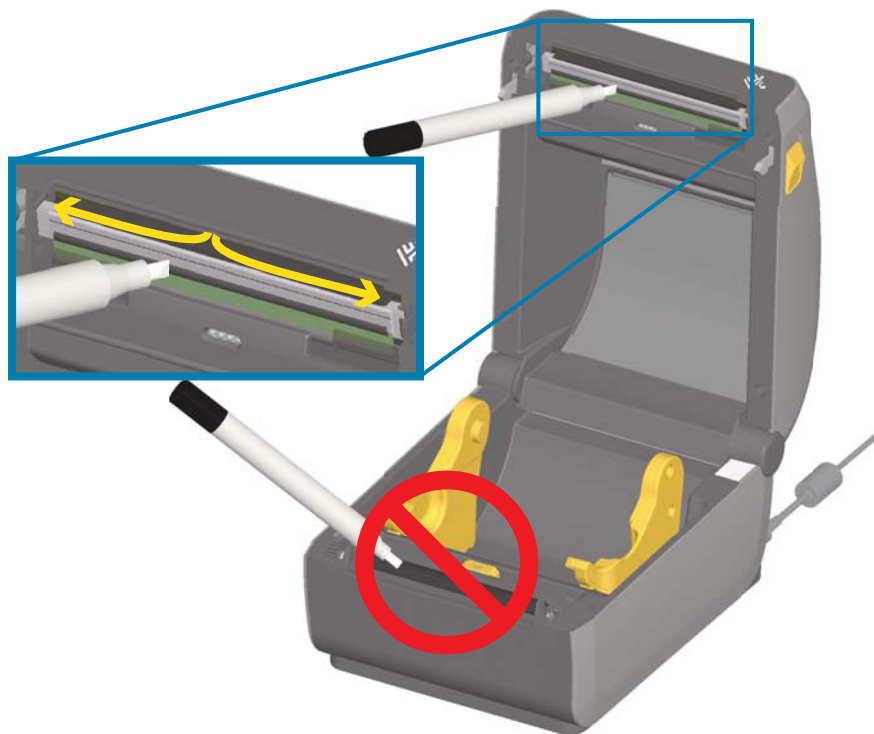

ZD621 / ZD421 Thermal Transfer Printers

When you load new media or ribbon, you can also clean the printhead.

1. If transfer ribbon is installed, remove it before proceeding.
2. Rub the cleaning pen across the dark area of the printhead. Clean from the middle to the outside. This will move adhesive transferred from the edges of media to the outside of media path.
3. Wait one minute before closing the printer or loading ribbon to allow all components to dry.

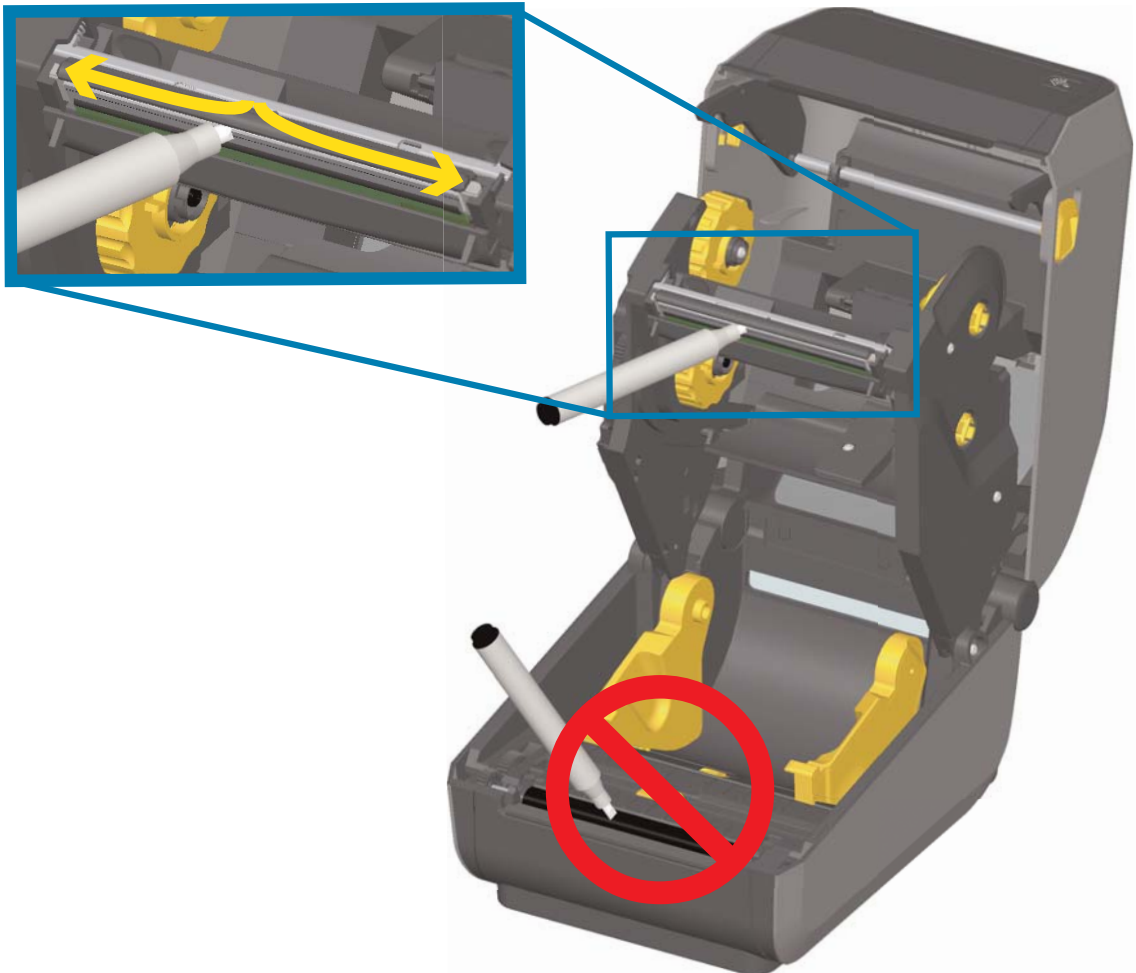

ZD421 Ribbon Cartridge Printers

1. Pull the two (2) Release Arms out to release the Ribbon Drive Transport. Go to [Accessing the Printhead of the Ribbon Cartridge Printer on page 29](#) for more details.
2. Lift the Printhead Actuator Arm up to gain access to the printhead. Rub the cleaning pen across the dark area of the printhead. Clean from the middle to the outside. This will move adhesive transferred from the outer edges of media to the area outside of media path.
3. Wait one minute before closing the printer.

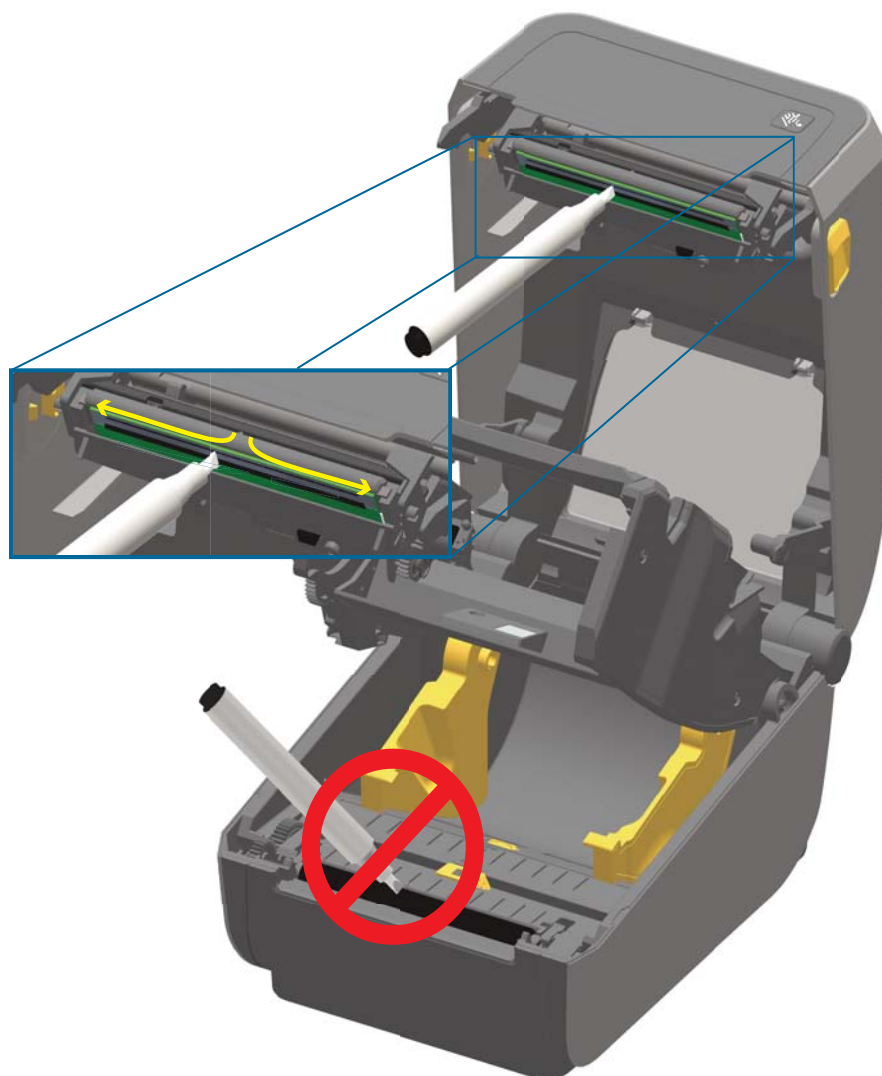

4. Release the Printhead Actuator Arm and then push the Ribbon Drive Transport into the Printhead Actuator Arm. The Release Arms will snap into place relinking the Ribbon Drive Transport to the top cover and the Printhead Actuator Arm.

Media Path Cleaning

Use a cleaning swab and/or a lint free cloth to remove debris, dust or crust that has built-up on the holders, guides and media path surfaces. Lightly moisten the swab or cloth with 99% solution isopropyl alcohol. For hard to clean areas, use extra alcohol on a cleaning swab to soak the debris to break up any adhesive that may have accumulated on surfaces in the media compartment.

Do not clean the printhead, sensors, or platen as part of this process.

Lower Half of ZD60/ZD421 Printers

The lower half of these printers these printers get cleaned the same.

1. Wipe the inside surfaces of the roll holders and the underside of the media guides with a cleaning swabs and wipes.
2. Wipe the movable sensor slide channel (but not sensor). Move the sensor to get to all areas.
3. Wait one minute before closing the printer. Discard used cleaning supplies.

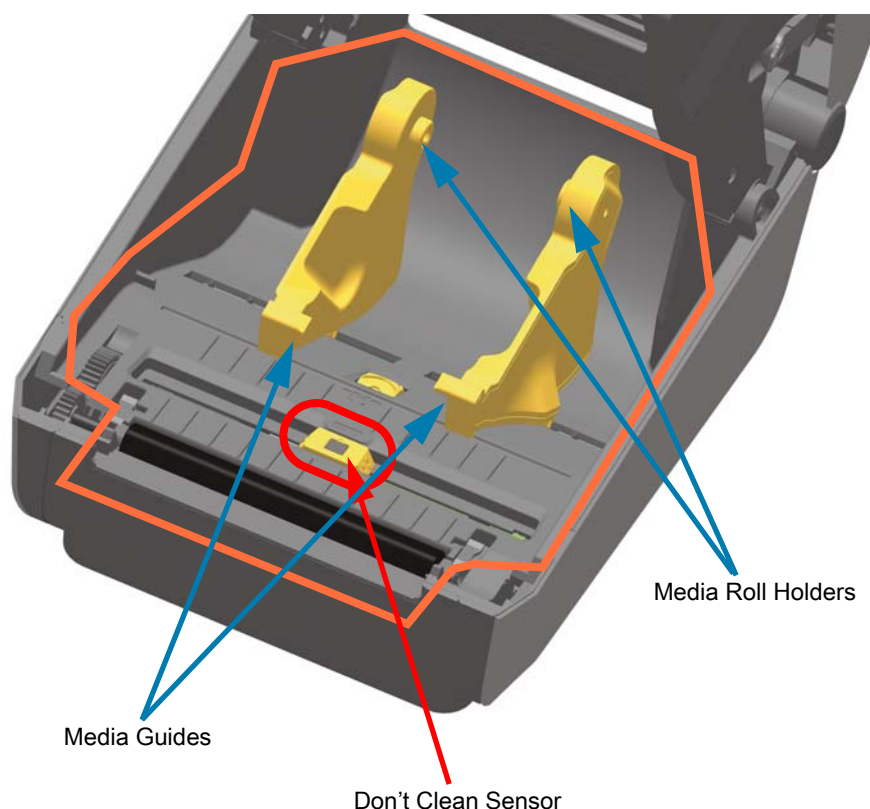

Upper Half of ZD621/ZD421 Direct Thermal Printers

1. Wipe the areas (outlined in orange) to remove adhesive and other contaminants. Do not clean the sensor array.

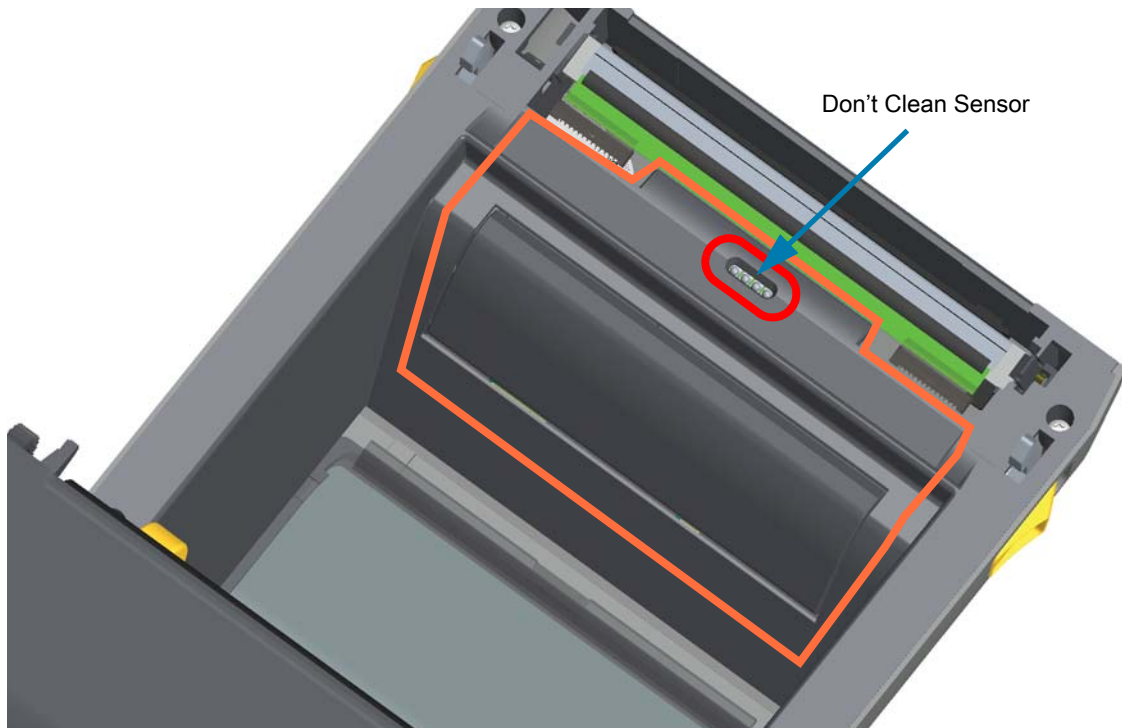

Upper Half of ZD621/420 Thermal Transfer Printers

1. Wipe the area (outlined in orange) near the printhead on the front of the ribbon carriage.

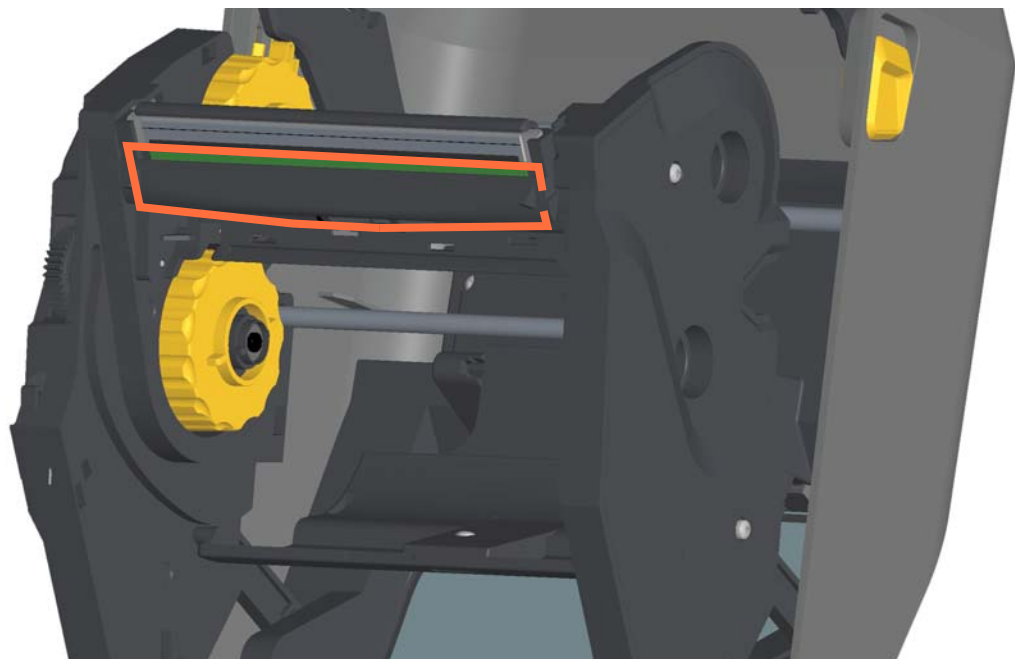

Upper Half of ZD421 Thermal Transfer Ribbon Cartridge Printers

1. Pull the two (2) Release Arms out to release the Ribbon Drive Transport. Go to [Accessing the Printhead of the Ribbon Cartridge Printer on page 29](#) for more details.
2. Wipe the areas (outlined in orange) below the Printhead Actuator Arm and the Ribbon Drive Transport.

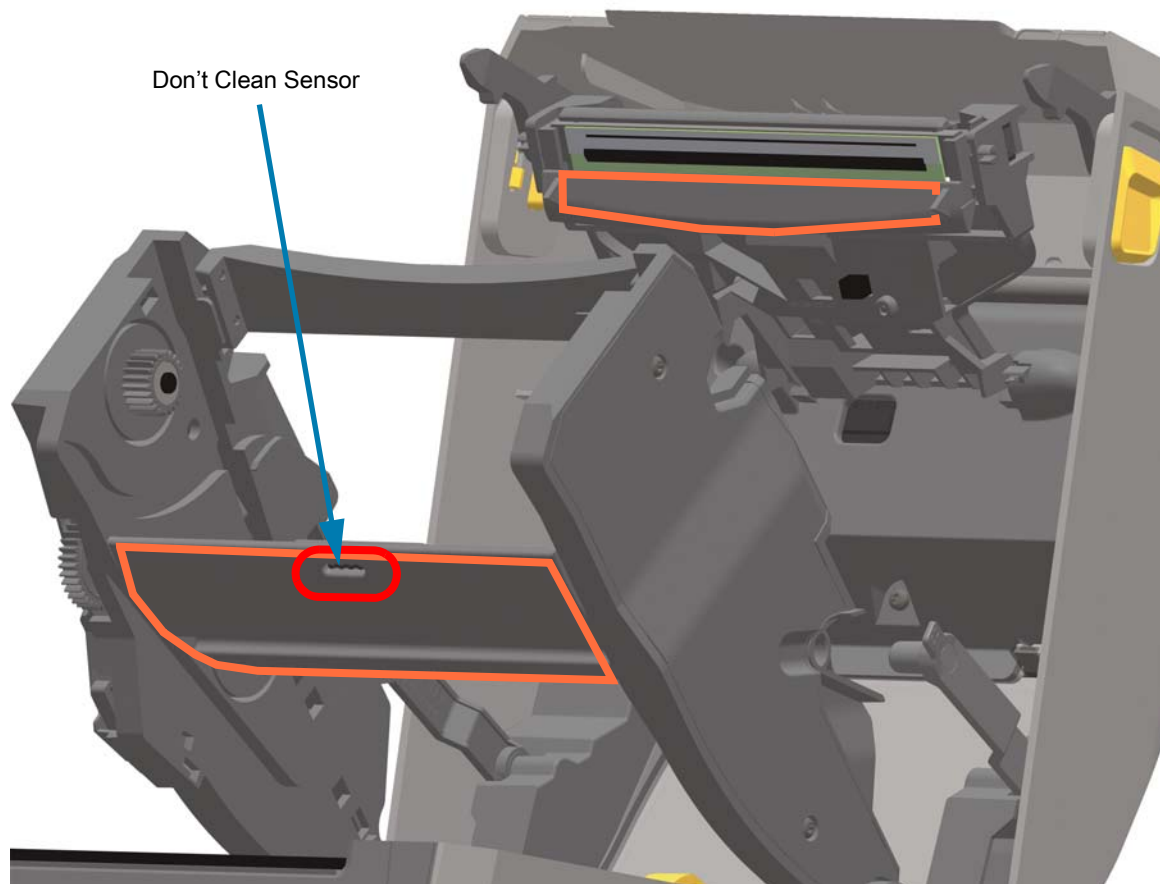

3. Release the Printhead Actuator Arm and then push the Ribbon Drive Transport into the Printhead Actuator Arm. The Release Arms will snap into place relinking the Ribbon Drive Transport to the top cover and the Printhead Actuator Arm.

Cleaning the Cutter and Label Dispenser Options

This is a continuation of cleaning the media path for either option, if installed.

Cutter Option Cleaning



IMPORTANT: The plastic media path surfaces can be cleaned but not the internal cutter blades or mechanism. The cutter blade mechanism does not require maintenance cleaning. **DO NOT** clean the blade. This blade has a special coating to resist adhesives and wear.



CAUTION: There are no operator serviceable parts in the cutter unit. Never remove the cutter cover (bezel). Never attempt to insert objects or fingers in to the cutter mechanism.



CAUTION—PRODUCT DAMAGE: Using un-approved tools, cotton swabs, solvents (including alcohol), etc. all may damage or shorten the cutter's usable life or cause the cutter to jam.

1. Wipe the ridges and the plastic surfaces of the media entry (inside) and exit slot (outside) of the cutter. Clean inside the areas outlined in blue.
2. Repeat as necessary to remove any adhesive or contaminate residue after it dries.

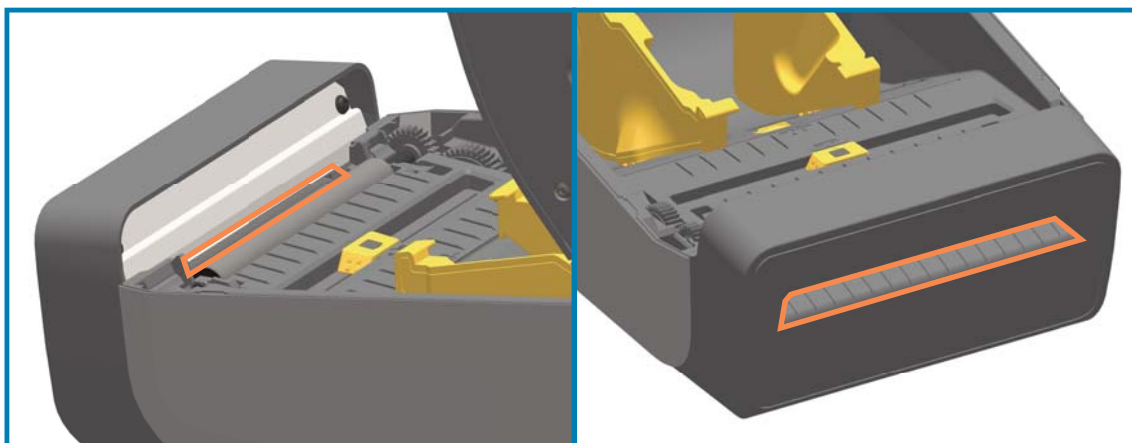

Label Dispenser Option Cleaning

1. Open the door and clean the peel bar, inner surfaces and ridges on the door.
2. Wipe the roller while rotating it. Discard the swab or cloth. Clean again to remove diluted residue.
3. Clean the sensor window. The window should be clear of streaks and residue.

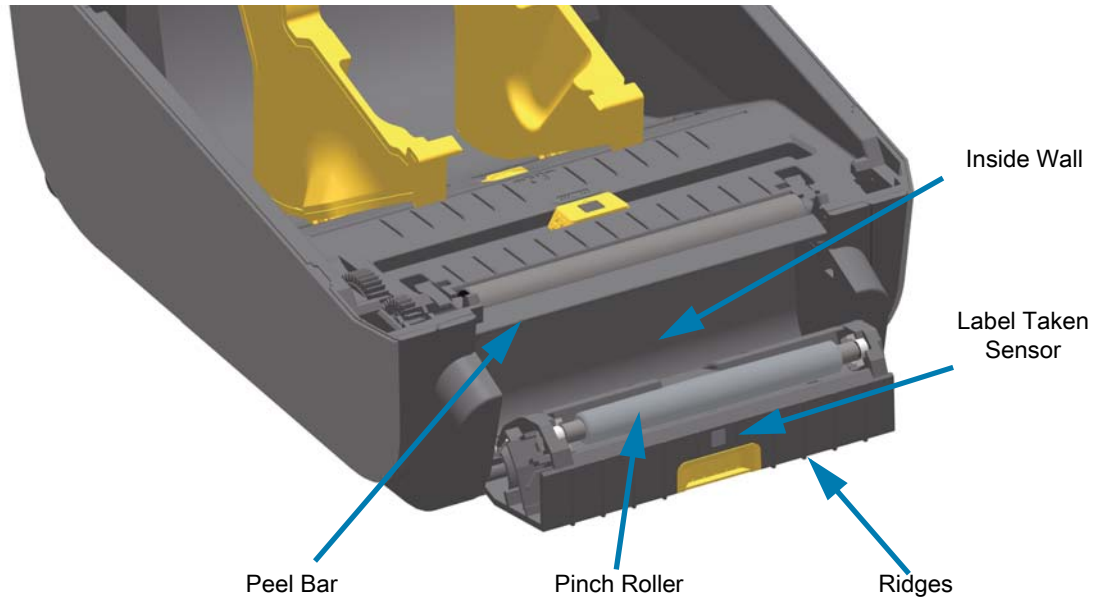

Sensor Cleaning

Dust can accumulate on the media sensors. Do not use an air compressor to remove dust. Compressors add moisture, fine grit, and lubricant which can contaminate your printer.

Lower Half of ZD60/ZD421 Printers

1. Clean the Movable Sensor's window. Gently brush away dust or use a can of compressed air; if necessary, use a dry swab to brush away dust. If adhesives or other contaminants remain, use an alcohol moistened swab to break it up.
2. Use a dry swab to remove any residue that may be left from the first cleaning.
3. Repeat steps 1 and 2 as required until all residue and streaks are removed from the sensor.

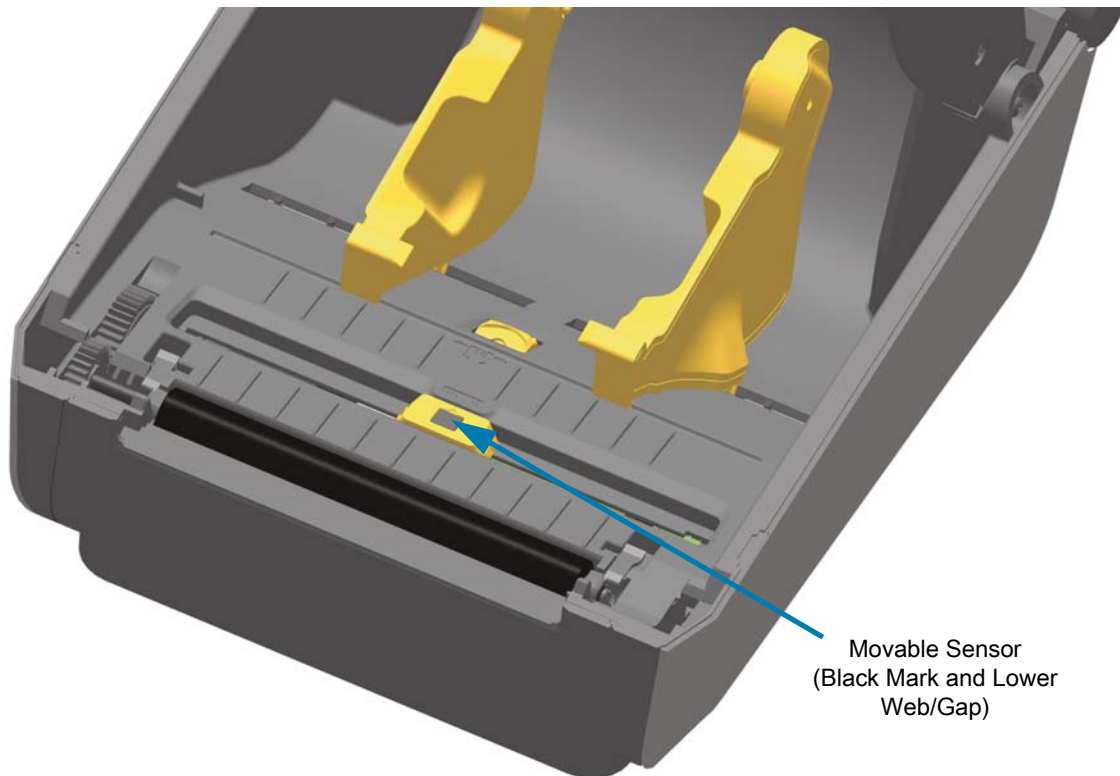

Upper Half of ZD621/ZD421 Direct Thermal Printers

1. Spray the Upper Web (Gap) Array Sensor below the printhead with a can of compressed air. If necessary, use an alcohol moistened swab to break up adhesive or other non-dust contaminants. Use a dry swab to remove any residue that may be left from the first cleaning.

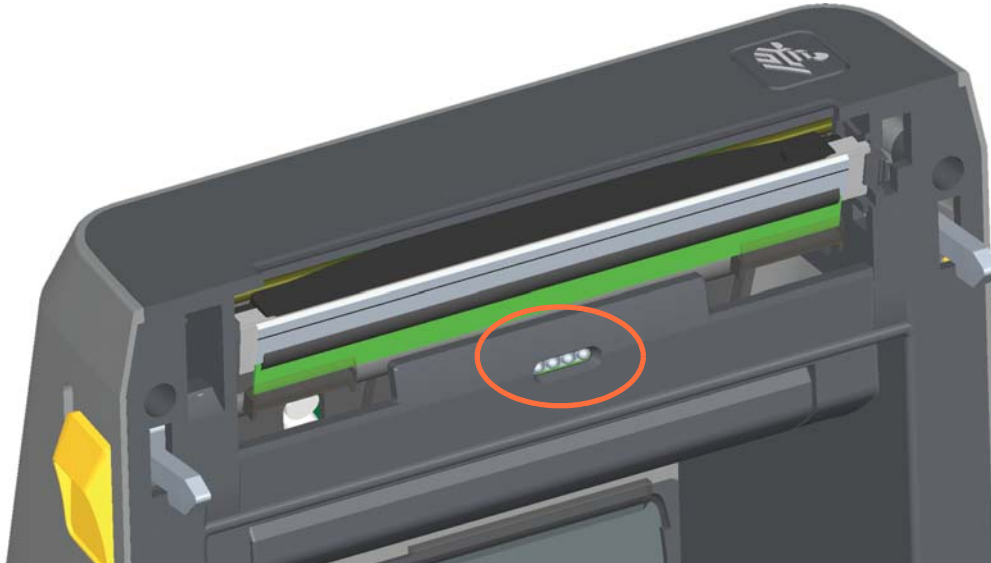

Upper Half of ZD621/ZD421 Thermal Transfer Printers

1. Spray the Upper Web (Gap) Array Sensor below the printhead with a can of compressed air. Complete sensor cleaning (very rare) requires a service technician

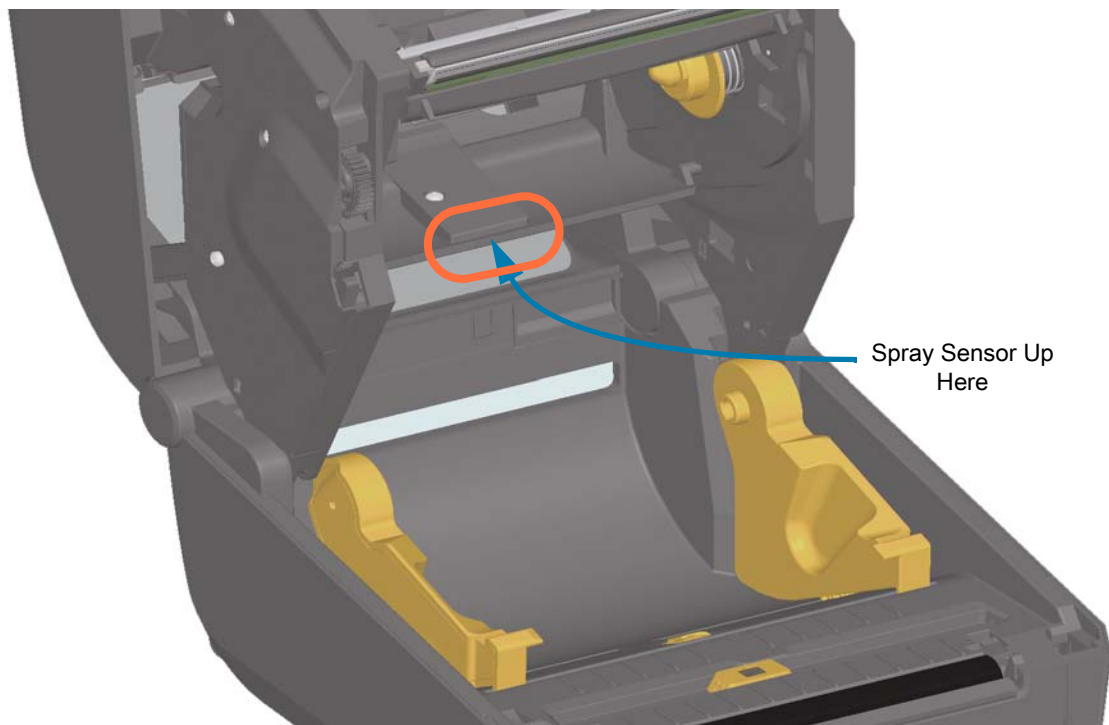

Upper Half of ZD421 Ribbon Cartridge Printers

1. Pull the two (2) Release Arms out to release the Ribbon Drive Transport. Go to [Accessing the Printhead of the Ribbon Cartridge Printer on page 29](#) for more details.
2. Swing the Printhead Actuator Arm up until it touches the printer's top cover. Hold the Printhead Actuator Arm in this position for access to the area below the printhead.
3. Spray the Upper Web (Gap) Array Sensor under the Ribbon Drive Transport and the Ribbon Out Sensor on the underside of the Printhead Actuator Arm with a can of compressed air. If necessary, use an alcohol moistened swab to break it up. Use a dry swab to remove any residue that may be left from the first cleaning.

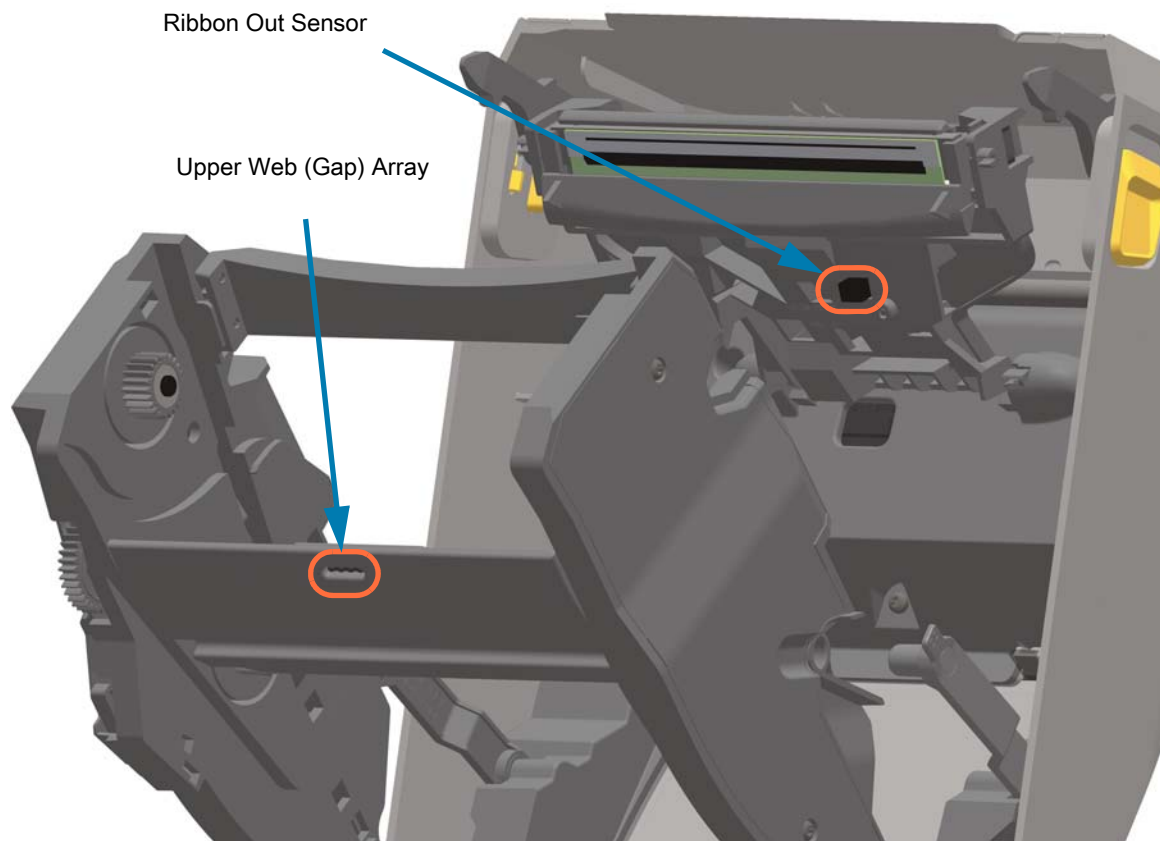

Cleaning Ribbon Cartridge Sensor

1. **Ribbon Cartridge Sensor Pins - Only clean when the cartridges are failing detection.** Clean the Ribbon Cartridge interface pins with a gentle wiping from right to left. Up and down motions may damage the pins.



Platen Cleaning and Replacement

The platen (drive roller) normally does not require cleaning. Normally, paper and liner dust can accumulate without affecting print operations.

Clean the platen (and media path) whenever the printer has significantly poorer performance, print quality or media handling. The platen is the print surface and drive roller for your media. If sticking or jamming continues even after cleaning, you must replace the platen.



IMPORTANT: Contaminants on the platen roller can damage the printhead or cause the media to slip or stick when printing. Adhesive, dirt, general dust, oils and other contaminants should be cleaned immediately off the platen.



CAUTION—PRODUCT DAMAGE: For LINERLESS PLATENS, do not wash or scrub. Only remove adhesive particles by using the adhesive side of linerless media. Lightly touch the platen roller with a linerless label to lift particles off the exposed area of the platen roller and the media path areas.

Removing the Platen Roller

The platen can be cleaned with a fiber-free swab (such as a Texpad swab) or a lint free, clean, damp cloth very lightly moistened with medical grade alcohol (90% pure or better).

1. Open the cover (and dispenser door, if the dispenser is installed). Remove media from platen area.
2. Pull the platen bearing latch release tabs on the right and left sides towards the front of the printer and rotate them up.

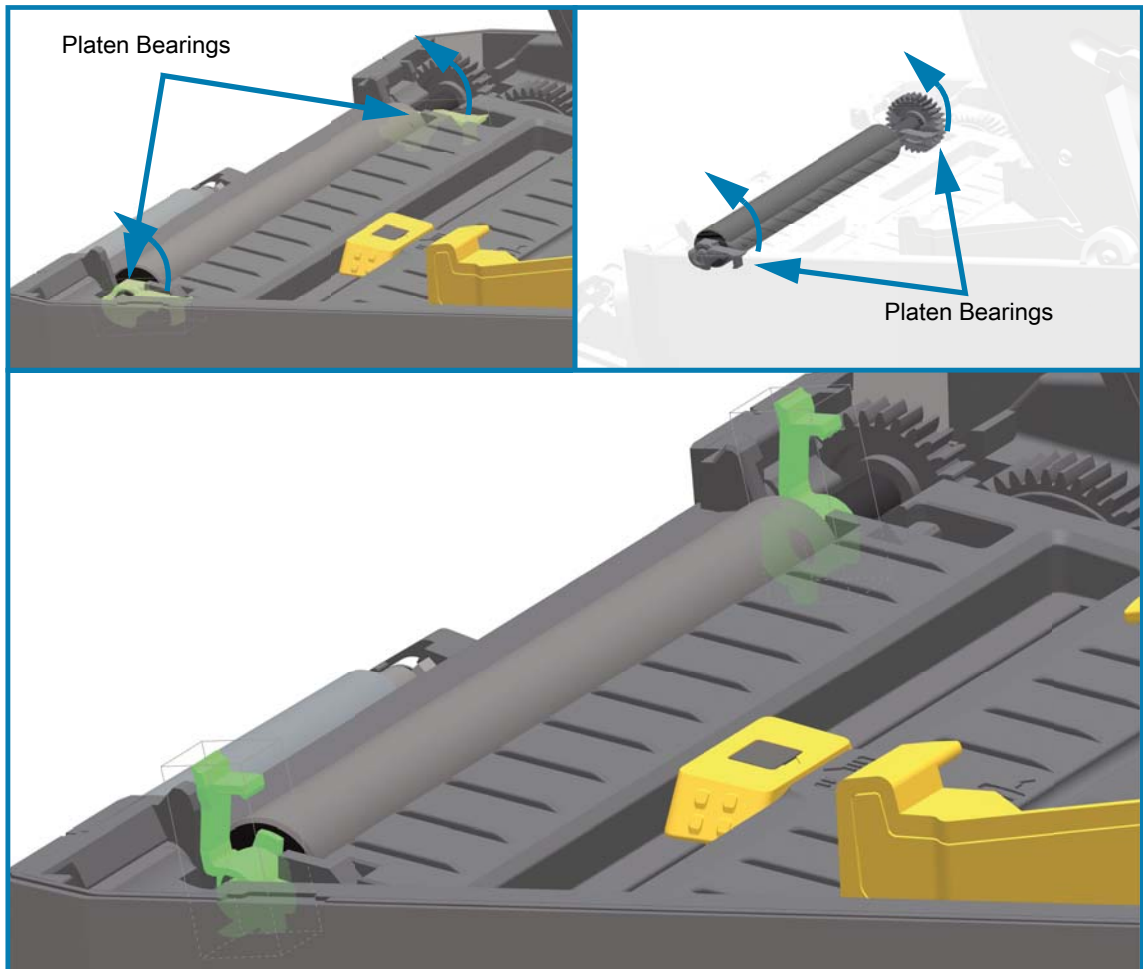

3. Lift the platen out of the printer's bottom frame.

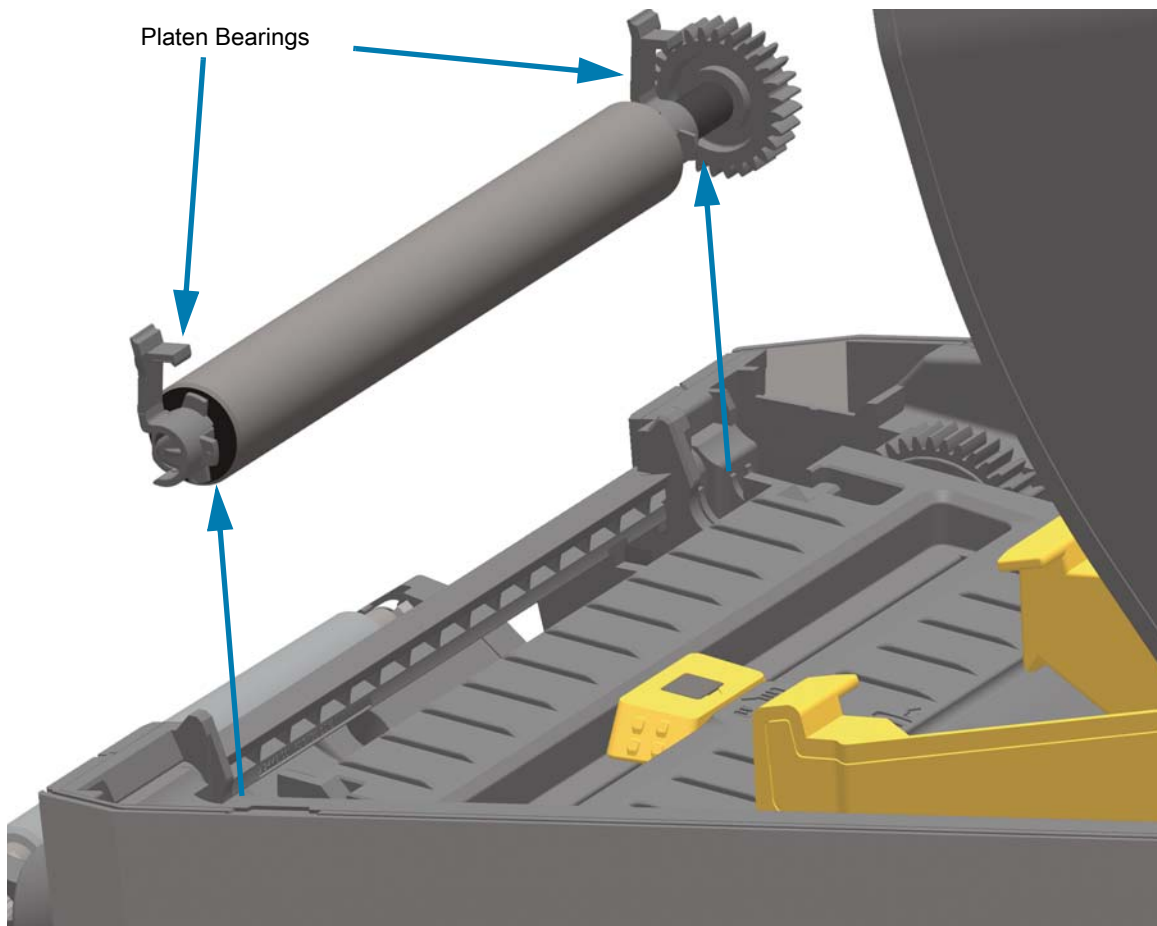

4. Slide the gear and the two (2) bearings off the shaft of the platen roller.

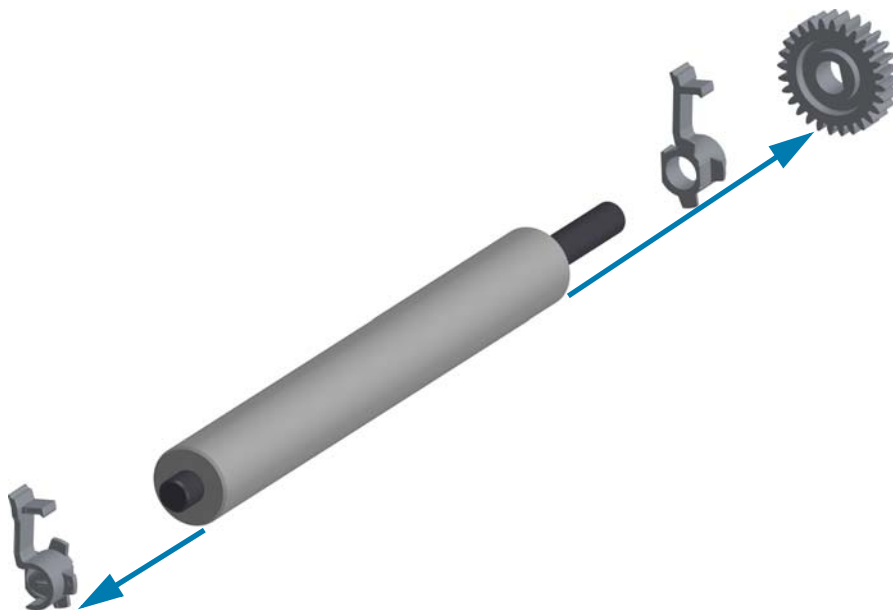

- Cleaning Only** — Clean the platen with the alcohol moistened swab. Clean from the center out. Repeat this process until all of the roller surface has been cleaned.

If there has been heavy adhesive build-up or label jam, repeat with a new swab to remove residual contaminants. Adhesives and oils, for example, may be thinned by the initial cleaning but not completely removed. Discard the cleaning swabs after use - do not reuse.



CAUTION—PRODUCT DAMAGE: For LINERLESS PLATENS, use only the adhesive side of a piece of linerless media to gently lift the particles from the plater roller for cleaning.

- Make sure the bearings and drive gear are on the shaft of the platen roller.

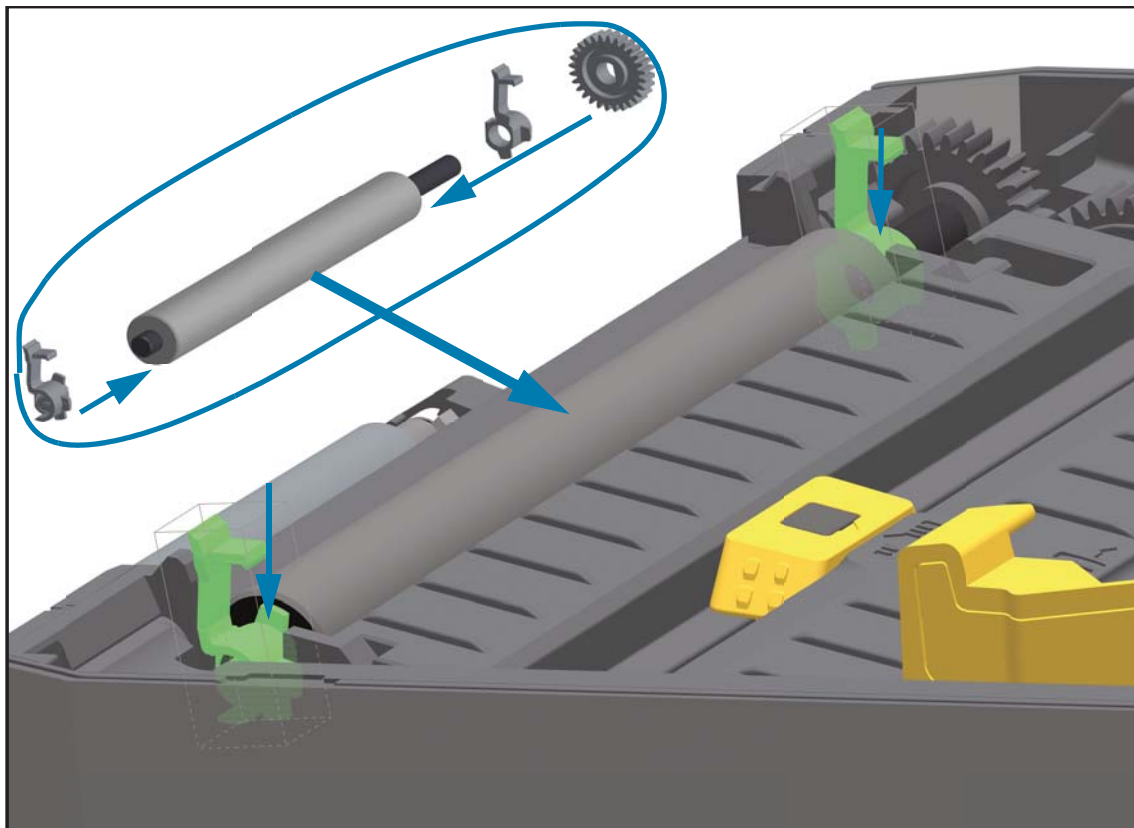

- Align the platen with the gear to the left and lower it into the printer's bottom frame.
- Rotate the platen bearing latch release tabs down on the right and left sides towards the rear of the printer and snap them into place.
- Allow the printer to dry for one minute before closing the dispenser door, media cover or loading labels.

Replacing the Printhead

If you need to replace the printhead, read the procedure and review the removal and installation steps before actually replacing the printhead.



CAUTION—ESD: Prepare your work area by protecting against static discharge. Your work area must be static-safe and include a properly grounded conductive cushioned mat to hold the printer and a conductive wrist strap for yourself.



CAUTION: Unplug the printer from the power supply and allow the printer to cool to prevent injuries or damage to printer circuitry.

Use one of the following model specific procedures to replace the printhead.

- [ZD621 and ZD421 Direct Thermal on page 260](#)
- [ZD621 and ZD421 Thermal Transfer Ribbon Roll on page 264](#)
- [ZD421 Thermal Transfer Ribbon Cartridge on page 269](#)

ZD621 and ZD421 Direct Thermal

Removing the Printhead

1. Turn the printer OFF. Open the printer.



2. Push the printhead release latch away from the printhead. The right side of printhead releases.

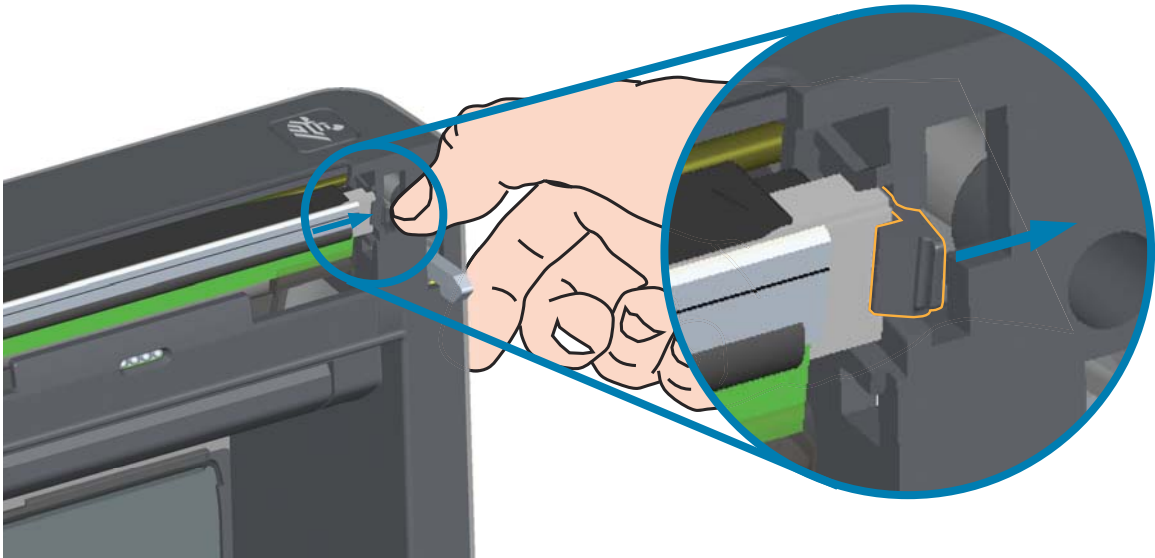

3. Swing the loose right side of the printhead out of the printer. Pull it out and to the right a little to get the left side of the printhead clear. Pull the printhead out and free of the top cover to gain access to its attached cables on the backside of the printhead. Note, the red highlights the left side printhead retainer slot.

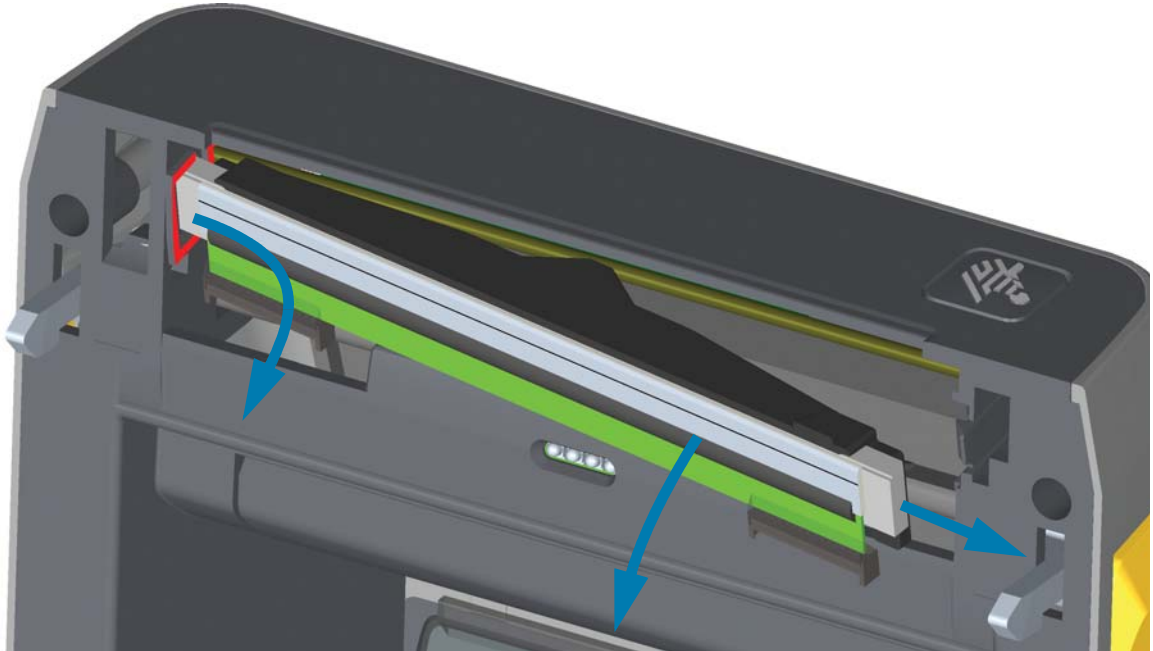

4. Gently but firmly pull the two printhead cable bundle connectors off of the printhead. Pull the ground wire off the printhead.

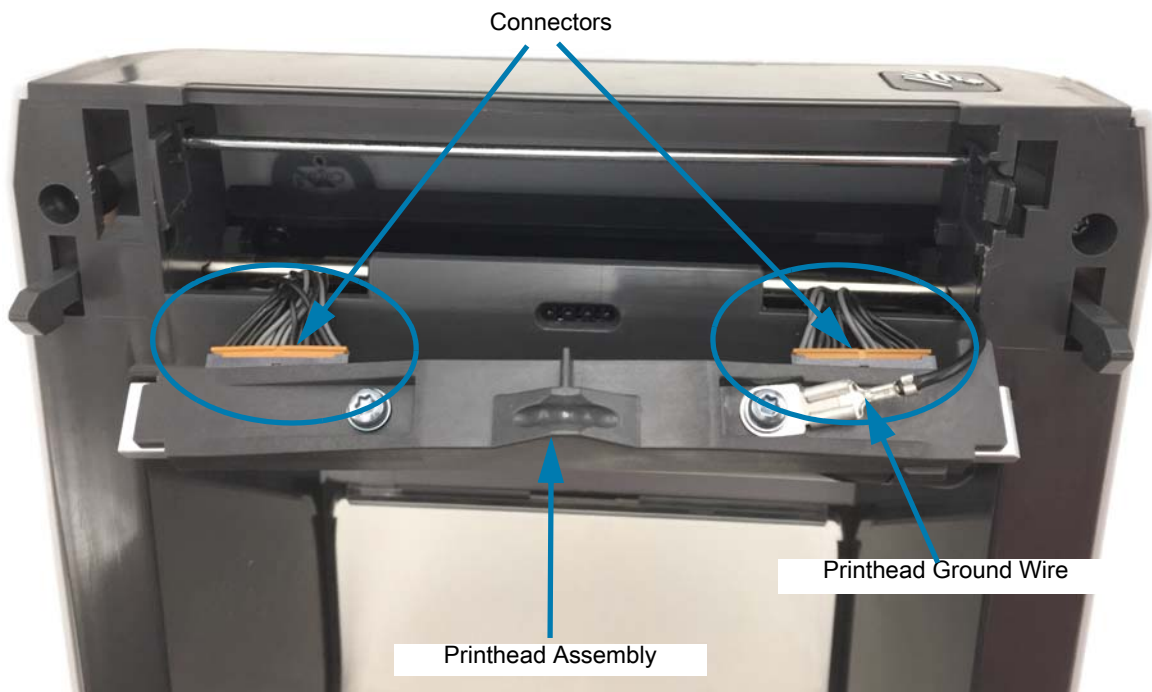

Replacing the Printhead

1. Push the right side printhead cable connector into the printhead. The connector is keyed to only insert one way.
2. Attach the ground wire to the printhead's ground tab.
3. Push the left side printhead cable connector onto the printhead.

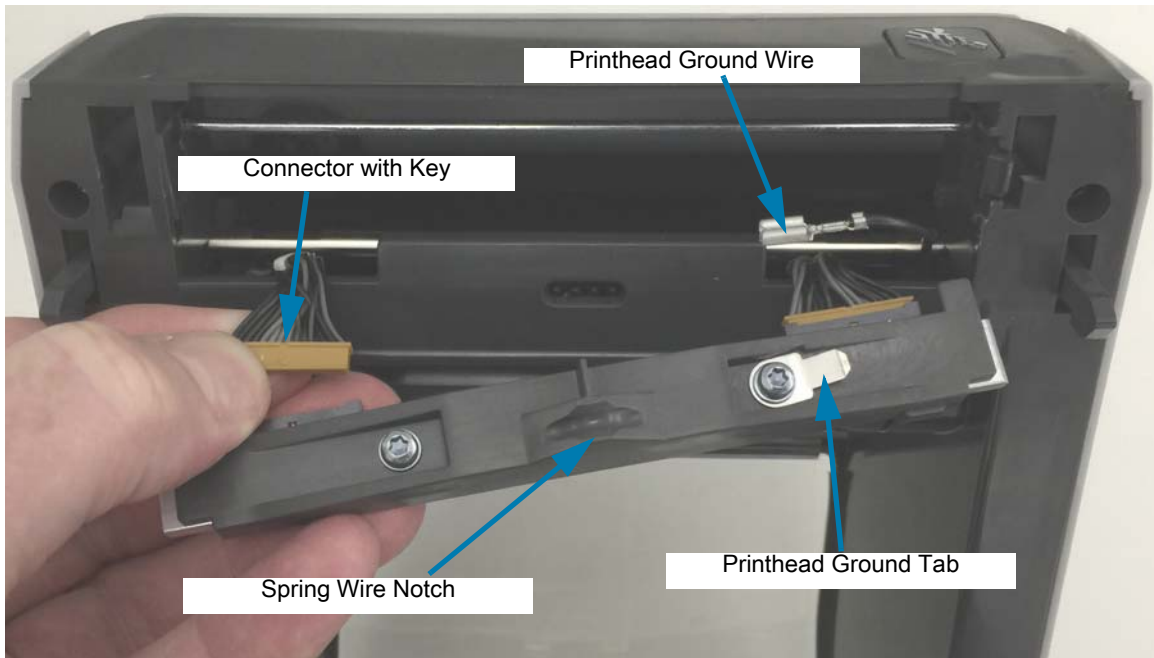

4. Insert the left side of the printhead assembly into the recessed slot (highlighted in red) on the left side of the printer.

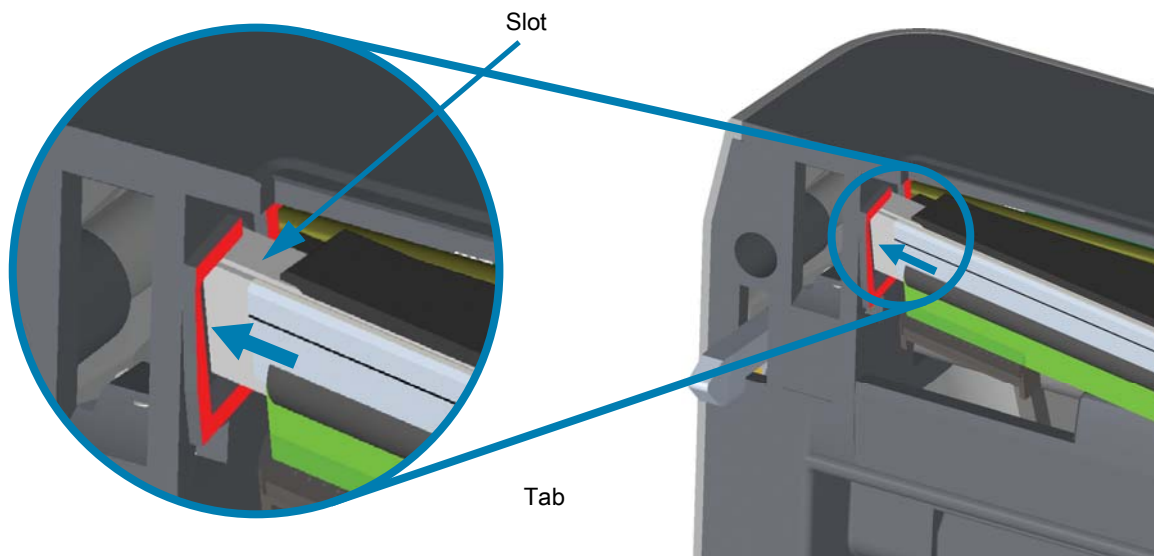

5. Align the Spring Wire Notch on the backside of the printhead to the Spring Wire. Push the right side of the printhead into the printer until the latch locks the right side of the printhead into the printer.

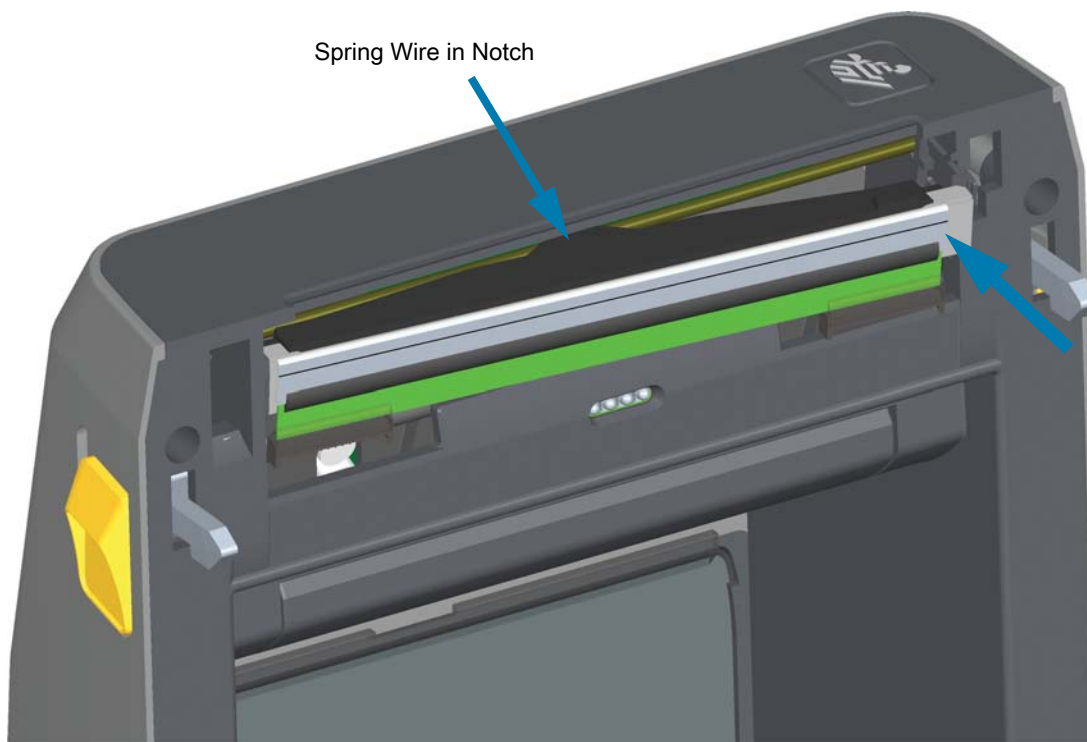

6. Verify that the printhead moves up and down freely when pressure is applied and remains locked when released.

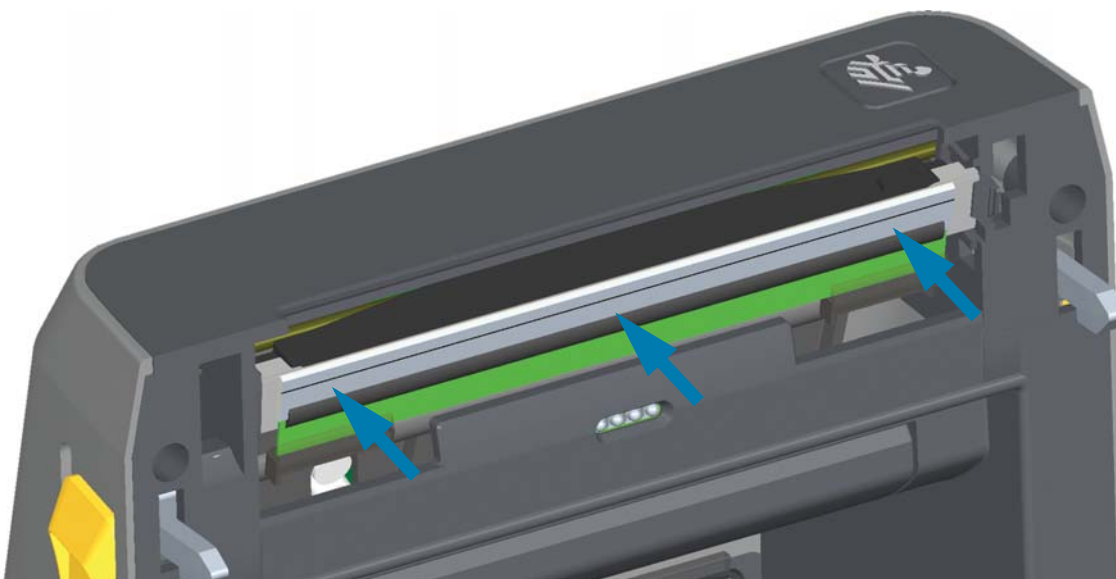

7. Clean the printhead. Use a new pen to wipe body oils (finger prints) and debris of the printhead. Clean from the center of the printhead to the outside. Go to [Cleaning the Printhead on page 243](#).
8. Reload media. Plug in the power cord, turn on the printer and print a status report to ensure proper function. Go to [Test Printing with the Configuration Report on page 178](#).

ZD621 and ZD421 Thermal Transfer Ribbon Roll

Removing the Printhead

1. Turn the printer OFF. Open the printer.

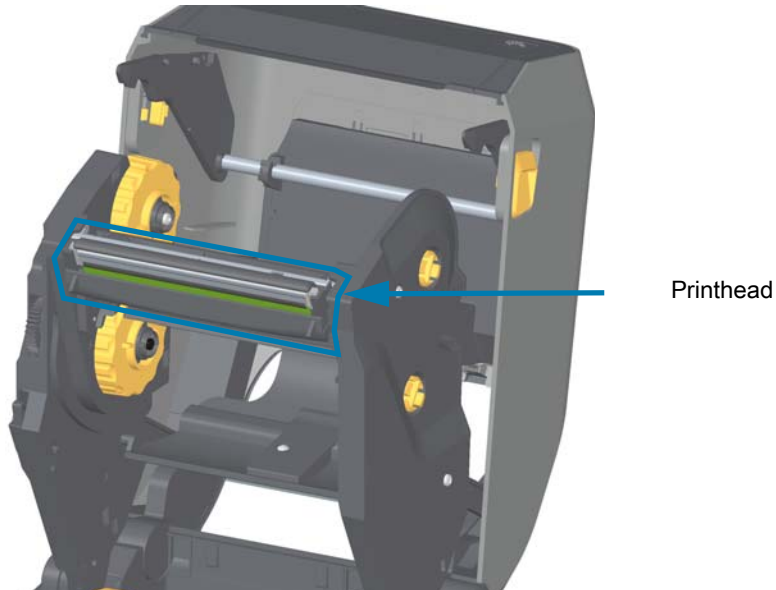

2. Push the printhead release latch toward the printhead (shown as green for visibility). The right side printhead releases down and away from the Printhead Actuator Arm.



3. Swing the loose right side of the printhead out of the printer. Pull it to the right a little to get the left side of the printhead clear. Pull the printhead down and free of the ribbon carriage to gain access to its attached cables.

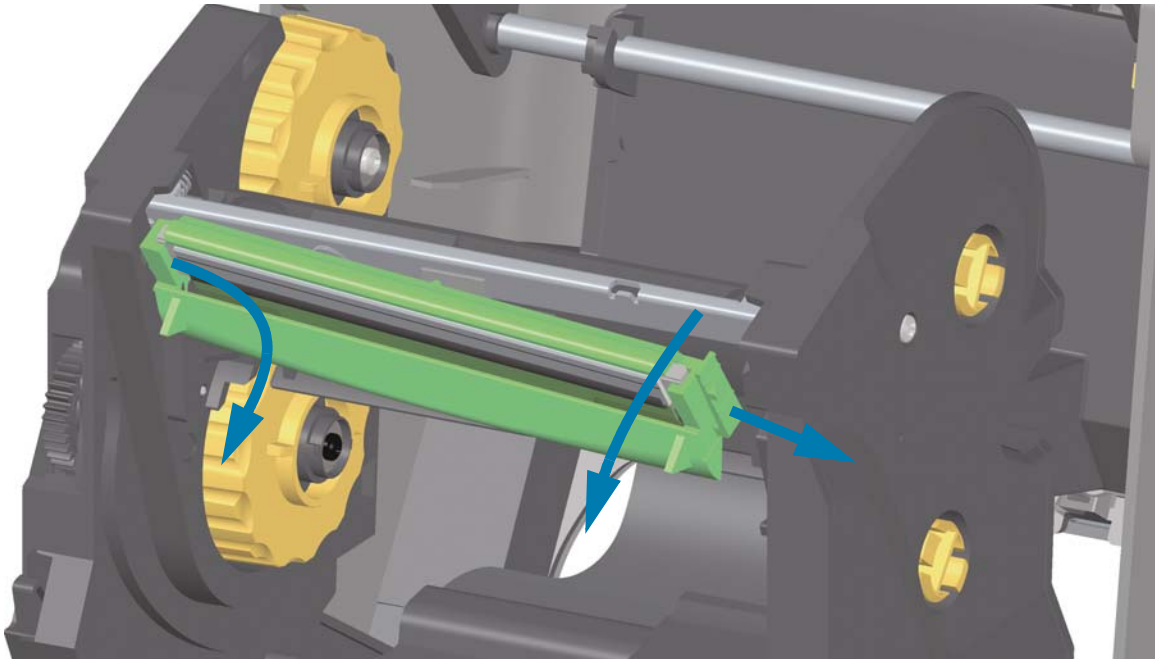

4. Gently but firmly pull the two printhead cable bundle connectors off of the printhead.

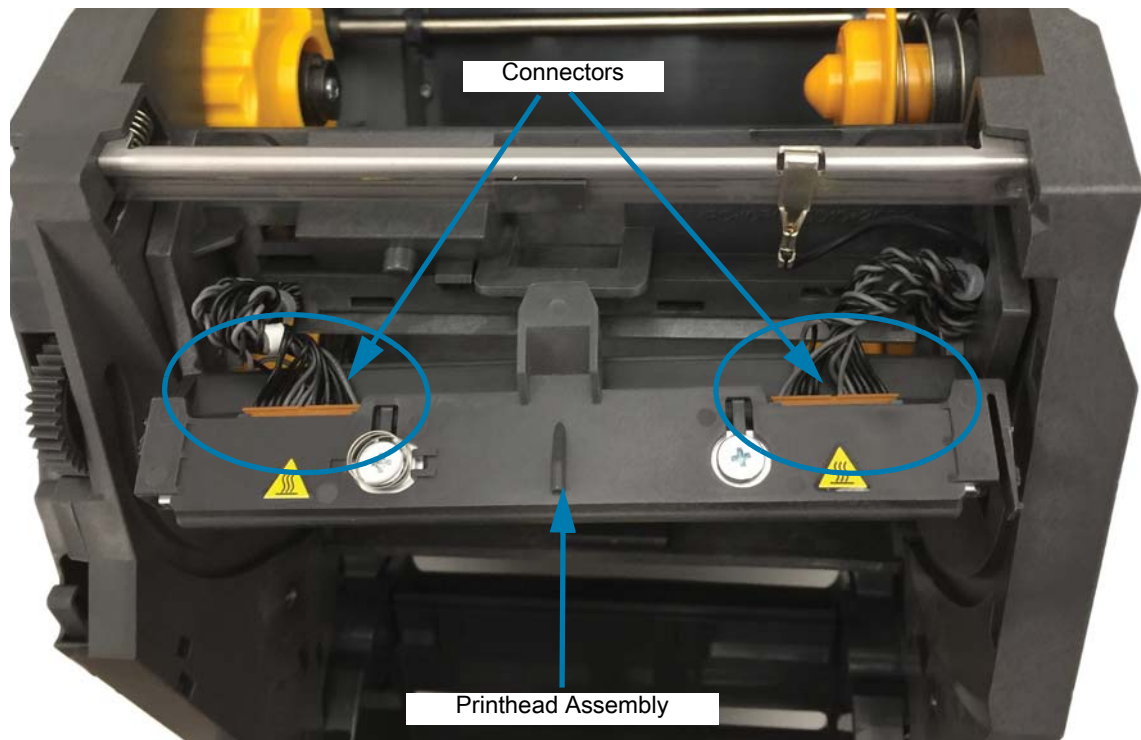

Replacing the Printhead

1. Push the right side printhead cable connector into the printhead. The connector is keyed to only insert one way.
2. Push the left side printhead cable connector onto the printhead.



3. Insert the center tab on the printhead assembly into the center slot on the Printhead Actuator Arm.

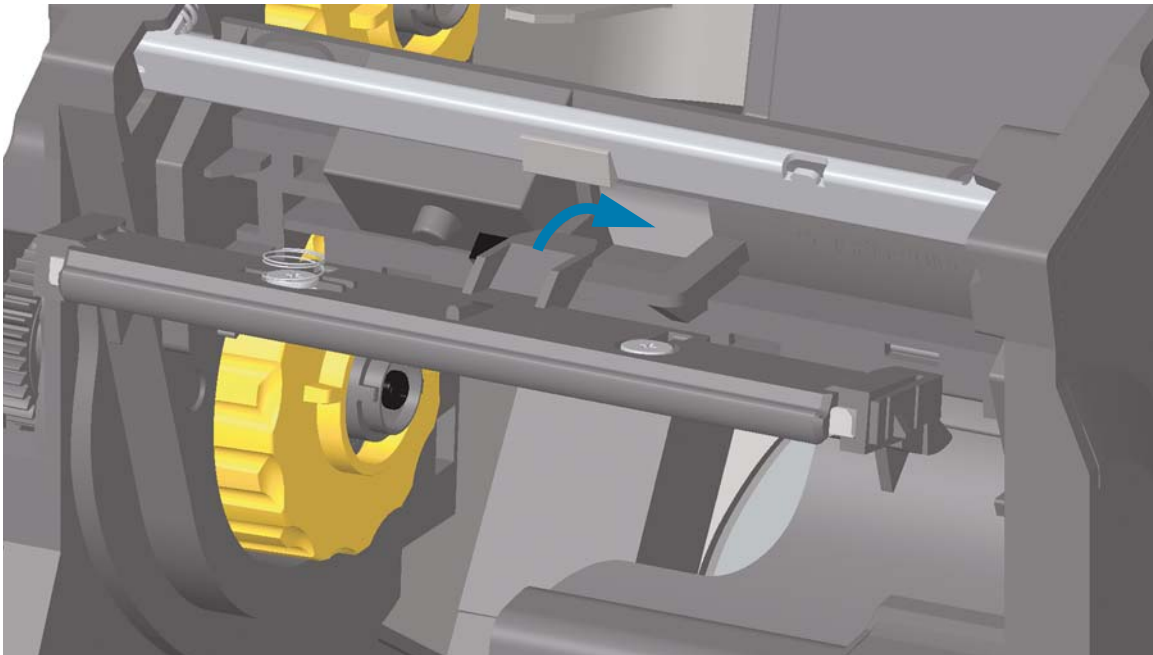

4. Insert the left side tab of the printhead assembly into the recessed slot on the left side of the Printhead Actuator Arm.

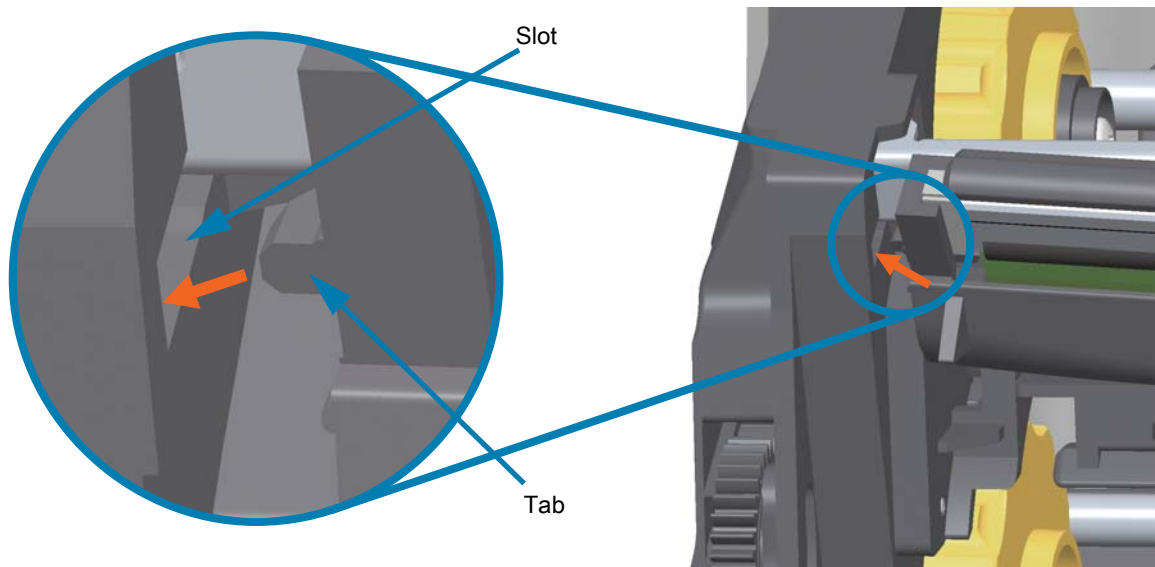

5. Push the right side of the printhead into the printer until the latch locks the right side of the printhead into the printer.

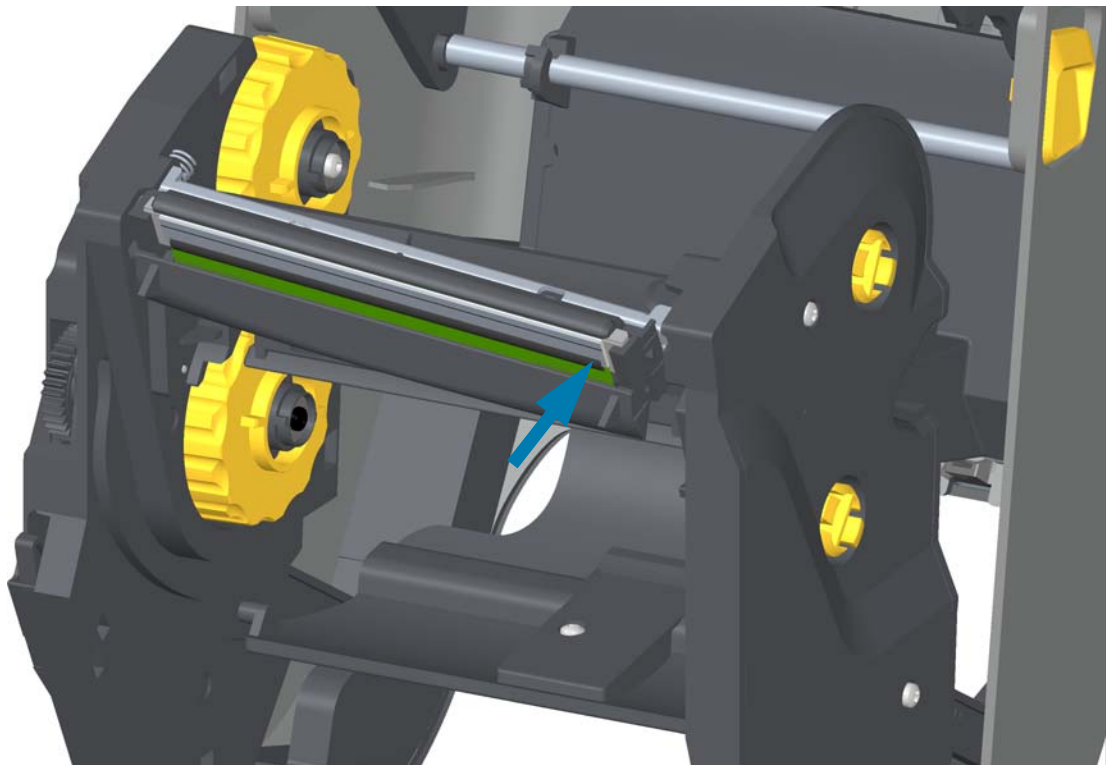

6. Verify that the printhead moves up and down freely when pressure is applied and remains locked when released.

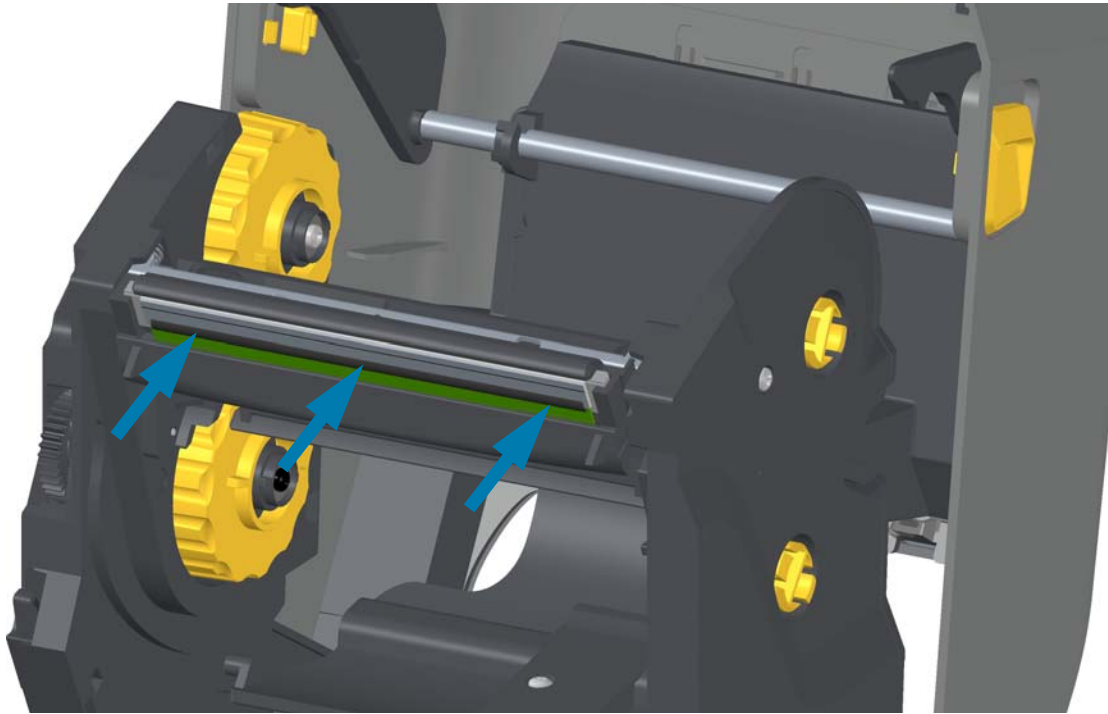

7. Clean the printhead. Use a new pen to wipe body oils (finger prints) and debris of the printhead. Clean from the center of the printhead to the outside. Go to [Cleaning the Printhead on page 243](#).
8. Reload media. Plug in the power cord, turn on the printer and print a status report to ensure proper function. Go to [Test Printing with the Configuration Report on page 178](#).

ZD421 Thermal Transfer Ribbon Cartridge

Printhead Removal

1. Turn the printer OFF. Open the printer.
2. Pull the two (2) Release Arms out to release the Ribbon Drive Transport. Go to [Accessing the Printhead of the Ribbon Cartridge Printer on page 29](#) for more details.
3. Swing the Printhead Actuator Arm up until it touches the printer's top cover. Hold the Printhead Actuator Arm in this position for access to the printhead. Push the printhead release latch toward the printhead (shown as pink for visibility). The right side printhead releases down and away from the Printhead Actuator Arm.

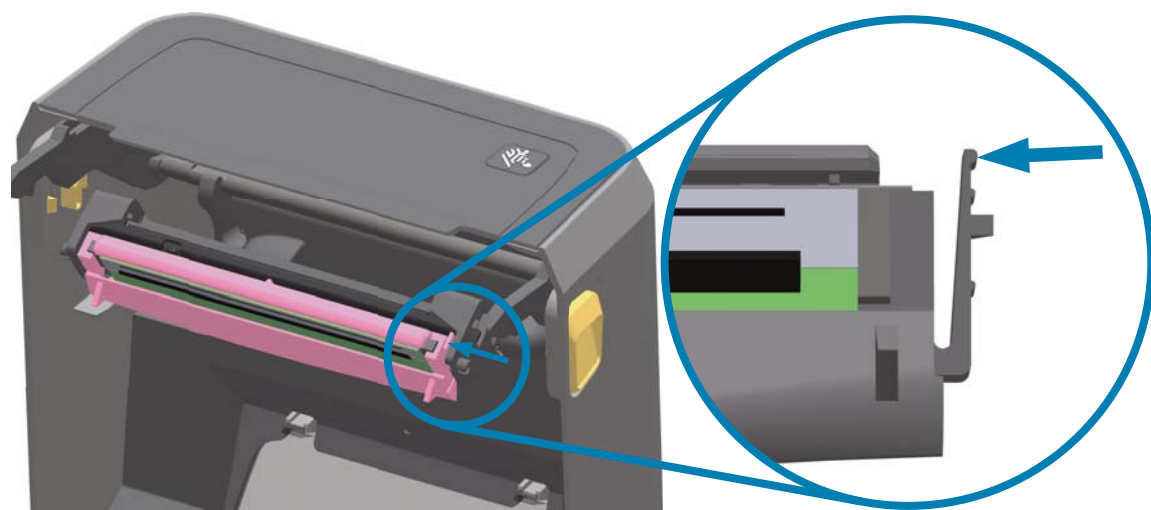

4. Swing the loose right side of the printhead out of the printer. Pull it to the right a little to get the left side of the printhead clear. Pull the printhead down and free of the Printhead Actuator Arm to gain access to its attached cables.

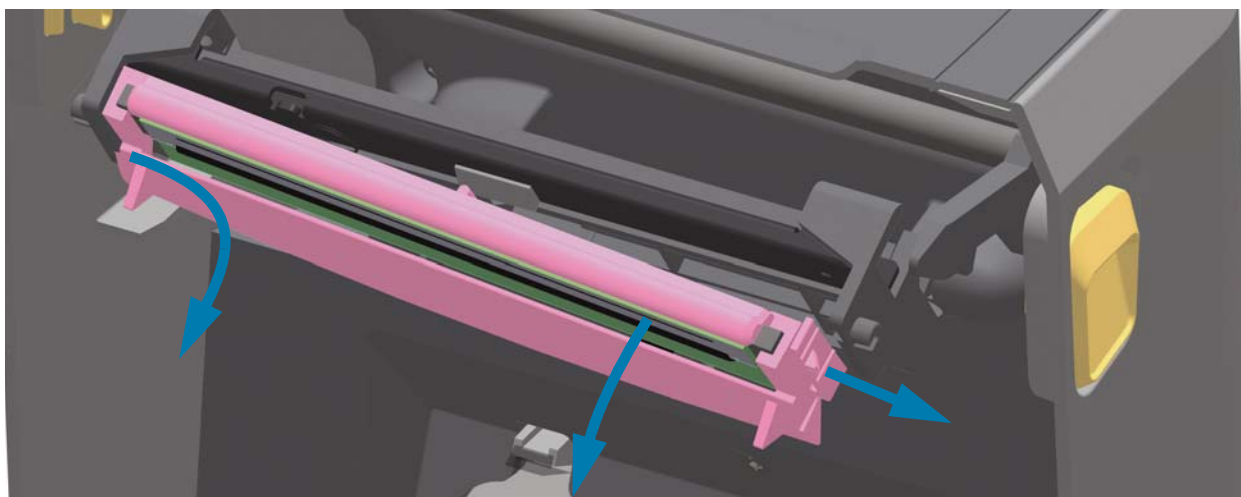

5. Gently but firmly pull the two printhead cable bundle connectors off of the printhead.

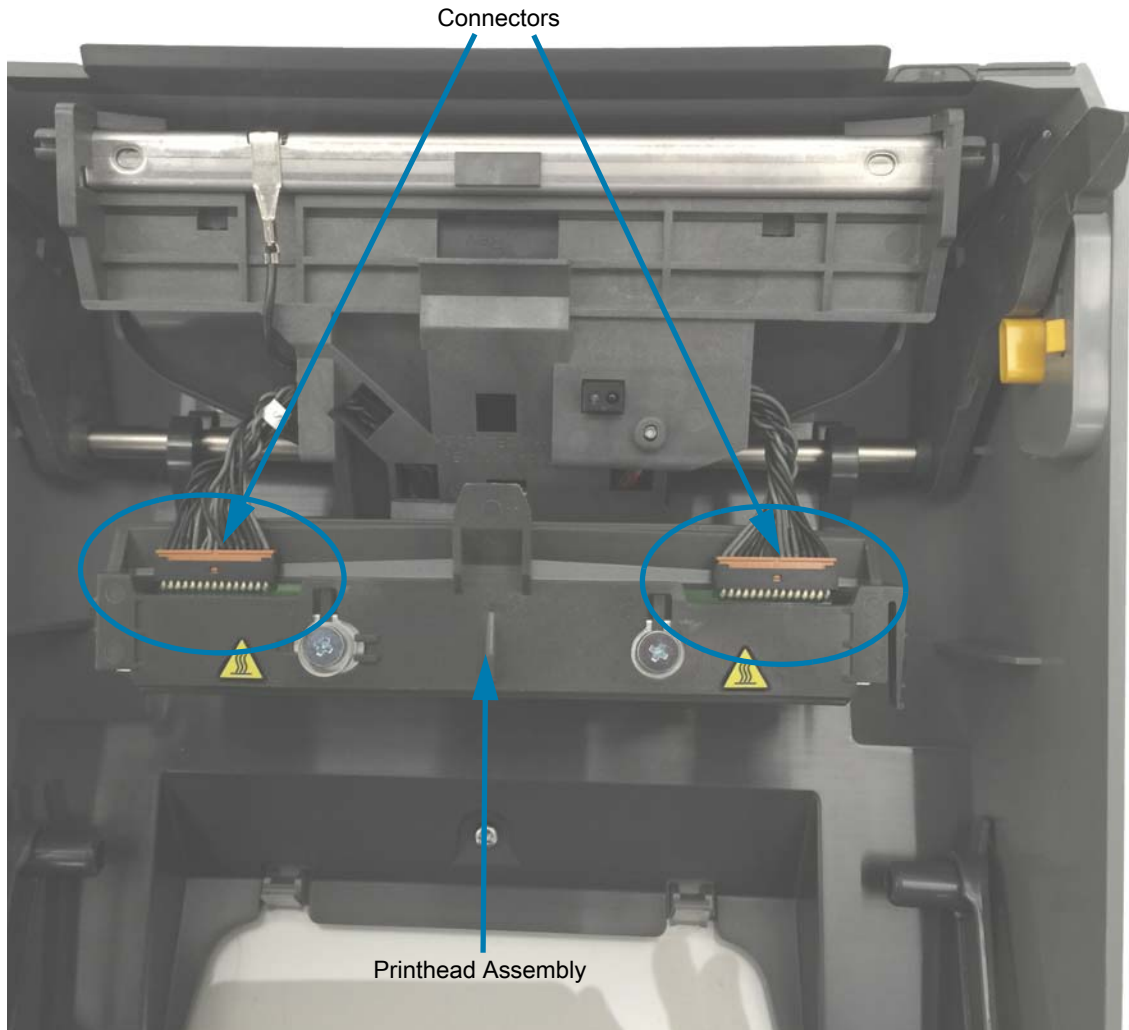

Replacing the Printhead

1. Push the right side printhead cable connector into the printhead. The connector is keyed to only insert one way.
2. Push the left side printhead cable connector onto the printhead.
3. Insert the center tab on the printhead assembly into the center slot on the Printhead Actuator Arm.

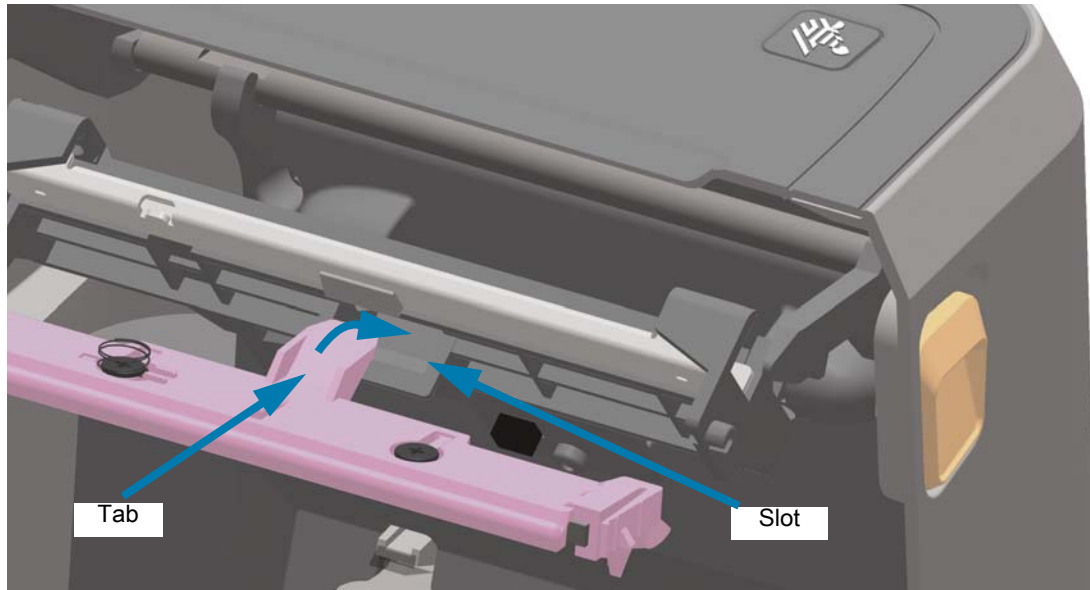

4. Insert the left side tab of the printhead assembly into the recessed slot on the left side of the Printhead Actuator Arm.

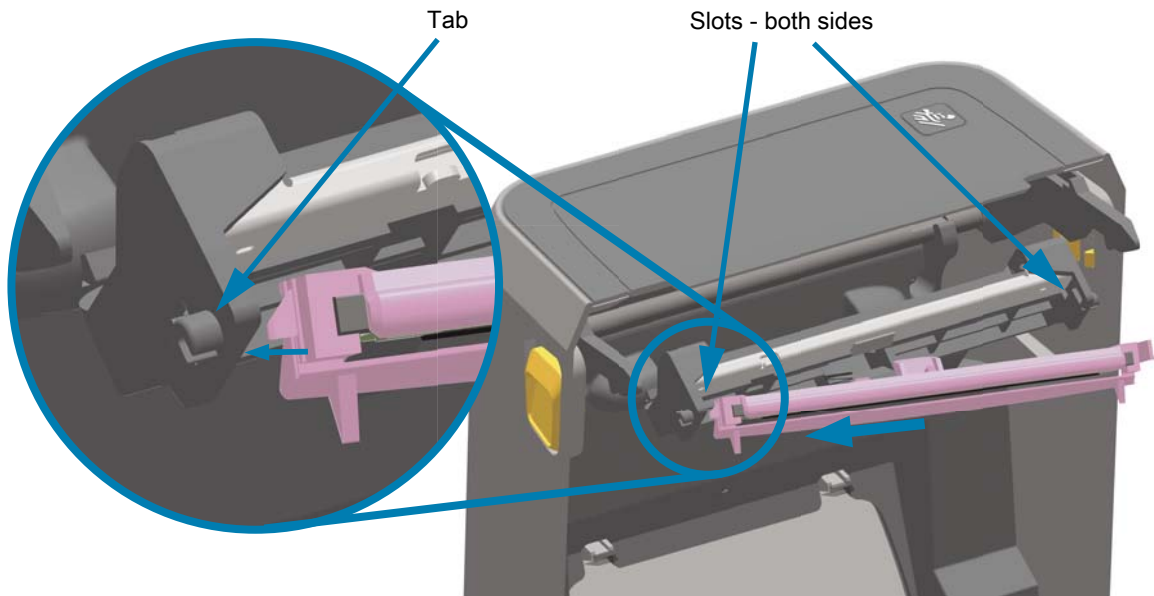

5. Push the right side of the printhead into the printer until the latch locks the right side of the printhead into the printer.

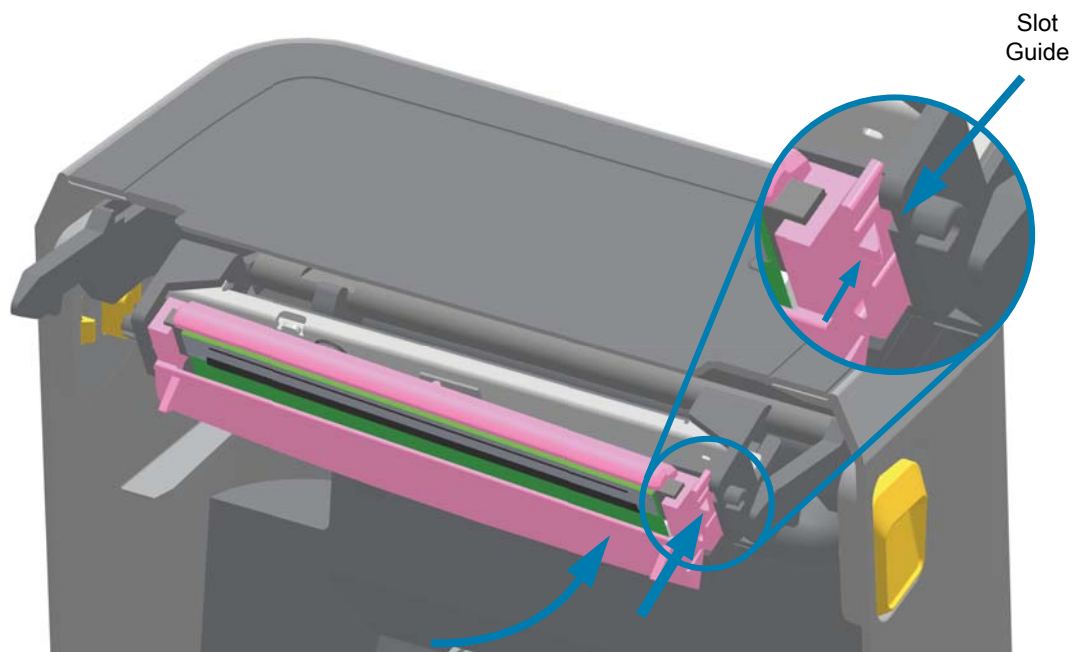

6. Verify that the printhead moves freely into the printer when pressure is applied (see arrow) and remains locked when pressure is released.

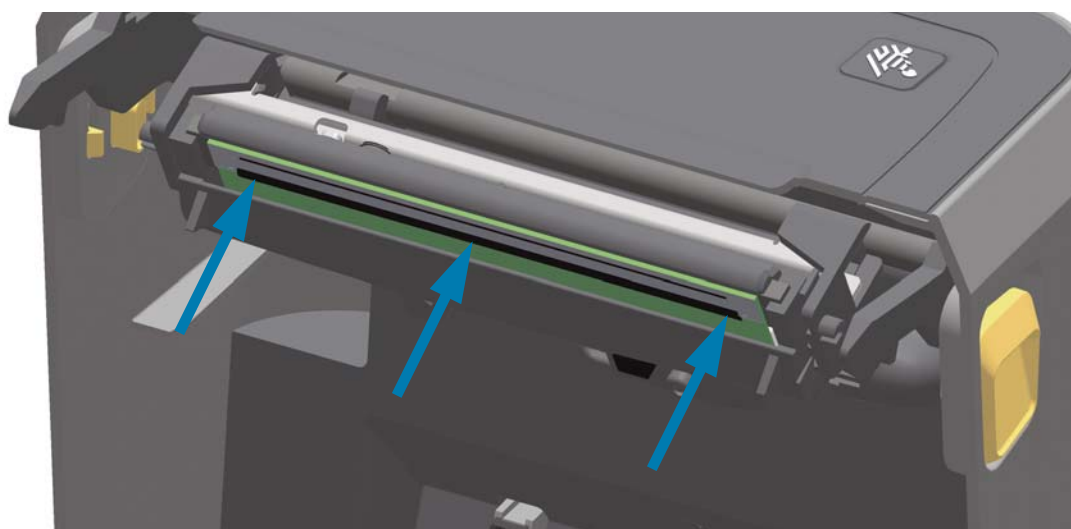

7. Clean the printhead by using a new cleaning pen to wipe body oils (fingerprints) and debris off the printhead. Go to [Cleaning the Printhead on page 243](#).
8. Reload media. Turn on the printer and print a status report to ensure proper function. Go to [Test Printing with the Configuration Report on page 178](#).

Updating Printer Firmware

The printer's firmware may need to be updated periodically to get new features, improvements, and printer upgrades for media handling and communications.

Use Zebra Setup Utilities (ZSU) to load new firmware.

1. Open Zebra Setup Utilities.
2. Select your installed ZD621/ZD421 printer.
3. Click on the **Open Printer Tools** button and a **Tools** window will open.
4. Click on the **Action** tab.
5. Load the printer with media. Go to [Loading Roll Media on page 158](#).
6. Click on **Send file**. The lower half of the window will present a filename and path with a **Browse (...)** button to select the latest firmware file you have downloaded from the Zebra Web site.

7. Observe the user interface and wait.

If the firmware version is different than the version installed on the printer, the firmware will download to the printer. The data indicator will flash green while the firmware is downloading. The printer will restart with all indicators flashing. When the firmware update has completed, the STATUS indicator will display solid Green as the firmware is validated and installed. A printer Configuration Report is automatically printed and the firmware update has been completed.

Other Printer Maintenance

There are no user level maintenance procedures beyond those detailed in this section. Go to [Troubleshooting on page 274](#) for more information on diagnosing printer and print problems.

RTC Battery

A Real Time Clock (RTC) is included with your printer.

The clock's battery is rated to provide approximately ten years of service and is not user replaceable.

Contact a Zebra authorized service technician to replace the battery. Refer to the warranty for your printer for more details at zebra.com/warranty



CAUTION: The printer has a three volt lithium battery. You can discern a low or flat battery if the printer provides a consistently delayed date stamp. Battery replacement must be performed by a qualified service technician. Only use a Zebra approved replacement battery.



IMPORTANT: Recycle batteries according to local your guidelines and regulations. Wrap the battery when disposing (or storing) to avoid a short circuit.



CAUTION: DO NOT short circuit the battery. Short circuiting the battery may result in heat generation, fire or bursting.



CAUTION: DO NOT heat, disassemble or dispose of battery in fire.

Fuses

There are no replaceable fuses in these printers or power supplies.

Troubleshooting

This section provides troubleshooting procedures and information.

Resolving Alerts and Errors

Alert: Printhead Open

A print command or a FEED button has been pressed and the printer has detected that the printhead (cover) is not closed.

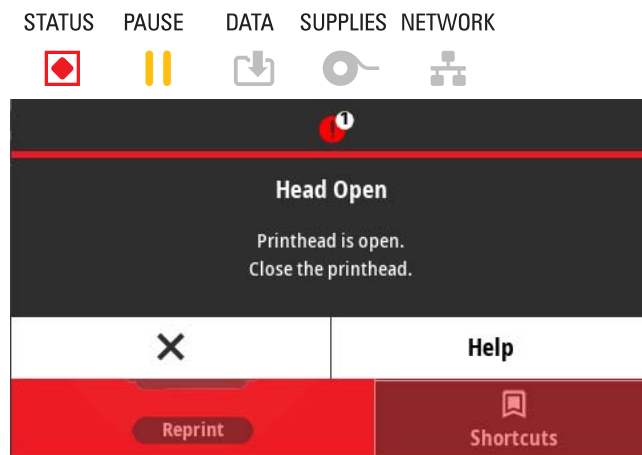

Possible Cause - 1

The cover is open or has not been closed properly.

Resolution

Close the cover/printhead. Push down on the front top corners of the printer's cover. You should normally hear and feel the cover latches snap in place to lock the cover closed for printing. Go to [Close the printer on page 19](#).

Possible Cause - 2

The printer's Head-Open switch needs service.

Resolution

Call a service technician.

Alert: Media Out

A print command, a FEED button has been pressed, or you are printing; and the printer can not detect media in the print path.



Possible Cause - 1

There is no media (roll) in the printer.

Resolution

Load your chosen media in the printer and close the printer. You may need to press the FEED button once or the PAUSE button to get the printer to resume your print operation. Go to [Loading Roll Media on page 158](#).

Possible Cause - 2

Open the printer: If there is a missing label on the roll between two labels at the end of a roll of labels, then this is a method used by the label roll manufacturer to identify the end of the roll. Go to [Detecting a Media Out Condition on page 179](#).

Resolution

Replace the empty media roll and continue printing. Do not power the print off or you will lose your print job. Go to [Detecting a Media Out Condition on page 179](#).

Possible Cause - 3

Misaligned media sensor.

Resolution

Check the position of the media sensor. Go to [Using the Movable Sensor on page 162](#). The printer may need to be calibrated for the media after the adjusting the sensor location. Go to [Run a SmartCal Media Calibration on page 177](#).

Possible Cause - 4

The printer is set for noncontinuous (labels or black mark) media, but continuous media is loaded.

Resolution

Check the position of the media sensor is in the center default location. Go to [Using the Movable Sensor on page 162](#).

The printer may need to be calibrated for the media after the adjusting the sensor location. Go to [Run a SmartCal Media Calibration on page 177](#).

Possible Cause - 5

The media sensor is dirty.

Resolution

Clean the Upper Web (Gap) Sensor Array and the lower Movable Media sensors. Go to [Sensor Cleaning on page 251](#).

Reload your media, adjust the Movable Media sensor's position for your media, and recalibrate the printer for the media. Go to [Loading Roll Media on page 158](#) and [Run a SmartCal Media Calibration on page 177](#).

Possible Cause - 6

The media sensing is not working. Possible data corruption of memory or faulty components.

Resolution

1. Reload the printer's firmware. Go to [Updating Printer Firmware on page 273](#).
2. If this does not fix this issue, call a service technician.

Alert: Ribbon In (ZD421 Cartridge Printer only)

A print command has been sent to the printer and it is in Direct Thermal Mode with Ribbon installed.



NOTE: The printer has two different heat settings - one for Direct Thermal and one for Thermal Transfer. They are designed to have equivalent print density/darkness at the same setting level.

STATUS PAUSE DATA SUPPLIES NETWORK



Possible Cause - 1

There is a Ribbon Cartridge in the printer while the printer is set to Direct Thermal Mode (and printing on direct thermal media).

Resolution

Remove the ribbon cartridge from the printer without turning the printer OFF. Close the printer. You may need to press the FEED button once or the PAUSE button to get the printer to resume your print operation.

Possible Cause - 2

The printer is incorrectly set to Direct Thermal Mode when you are trying to print using Transfer Media and Ribbon Cartridge to print.

Resolution

Change the PRINT METHOD to THERMAL TRANS (Thermal Transfer) mode. The print format/form send for this print job may have Direct Thermal mode set with a ^MTD set instead of ^MTT. Refer to the ZPL Programming Guide for details on printer programming. For printer links to manuals, to [About on page 11](#).

To change this setting:

- Use the printer's color touch display user interface (if present) to change the setting. Go to [Print > Print Quality > Print Type on page 120](#).
- Use an Ethernet (LAN or WLAN) printer's Print Server Web page to access and set the PRINT METHOD to THERMAL TRANS (Thermal Transfer) mode. Go to [Print > Print Quality > Print Type on page 120](#) for navigating the print server users interface.

Alert: Ribbon Out

- The printer is printing and stops while printing.
- A print job has been sent to the printer and the printer immediately reports this Alert.

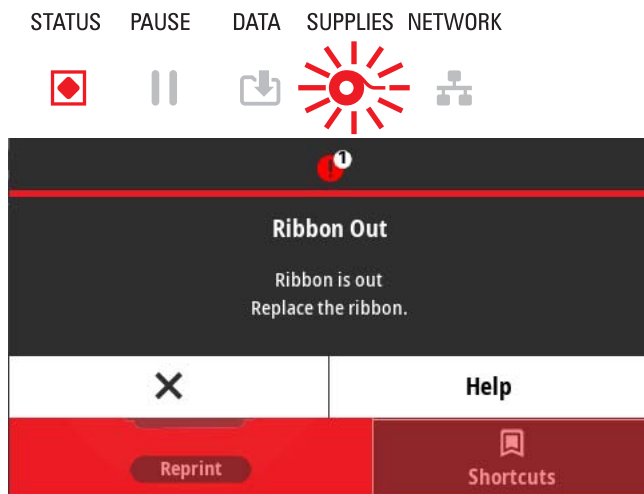

Possible Cause - 1

The printer has detected the end of the ribbon. The end of the ribbon has a reflective trailer on the end of Genuine Zebra Transfer Ribbon that the printer 'sees' as End of Ribbon.

Resolution

Remove the ribbon and replace the ribbon rolls or ribbon cartridge in the printer without turning the printer OFF. Close the printer. You may need to press the FEED button once or the PAUSE button to get the printer to resume your print operation. Go to [Detecting a Ribbon Out Condition on page 180](#).

Possible Cause - 2 (ZD421 Cartridge Printer only)

A ribbon cartridge needs to be loaded in the printer. The printer is set for Thermal Transfer Mode. Go to [Loading the ZD421 Ribbon Cartridge on page 176](#).

Possible Cause - 3 (ZD421 Cartridge Printer only)

The media sensing is not working. Possible dirty ribbon cartridge data chip or cartridge sensor contacts; data corruption of memory; or faulty cartridge or printer components.

Resolution

1. Try another working ribbon cartridge, if available.
2. Clean the Ribbon Cartridge chip with an alcohol moistened swab.
3. Clean the Ribbon Cartridge Sensor's contact pins. Go to [Upper Half of ZD421 Thermal Transfer Ribbon Cartridge Printers on page 248](#) for cleaning instructions.
4. Reload the printer's firmware. Go to [Updating Printer Firmware on page 273](#).
5. If this does not fix this issue, call a service technician.

Possible Cause - 4 (Standard Roll - Thermal Transfer Printers)

The media sensing is not working.

Resolution

1. Reload the printer's firmware. Go to [Updating Printer Firmware on page 273](#).
2. If this does not fix this issue, call a service technician.

Alert: Ribbon Low (ZD421 Cartridge Printer only)

The printer reports this Alert.

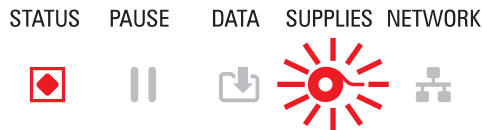

Possible Cause - 1

The printer has calculated that the ribbon cartridge has only 10% of the ribbon left in the cartridge. The ribbon low value can be changed by programming.

Resolution

Check for the availability of ribbon cartridges. To change the Ribbon Low warning point, go to the SGD commands - [Ribbon Cartridge Programming Commands on page 218](#). Refer to the ZPL Programming Guide for details on printer programming. For printer links to manuals, go to [About on page 11](#) .

Alert: CUT ERROR

The cutter blade is bound and is not moving properly.

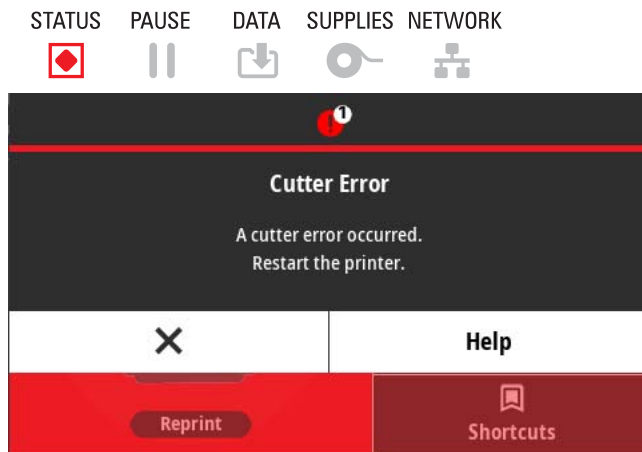

Possible Cause - 1

Media, adhesive, or external object has stopped the cutter blade from operating.

Resolution

1. Turn the printer off by holding the power button down for 5 seconds. Wait for the printer to shutdown completely. Turn the printer on.
2. If the printer does not recover from this error, call a service technician. This is not a operator serviceable item.



CAUTION: There are no operator serviceable parts in the cutter unit. Never remove the cutter cover (bezel). Never attempt to insert objects or fingers in to the cutter mechanism.



NOTE: Using unapproved tools, cotton swabs, solvents (including alcohol), etc. all may damage or shorten the cutter's usable life or cause the cutter to jam.

Alert: PRINTHEAD OVER TEMP

The printhead is over temperature and paused to allow the printhead to cool.

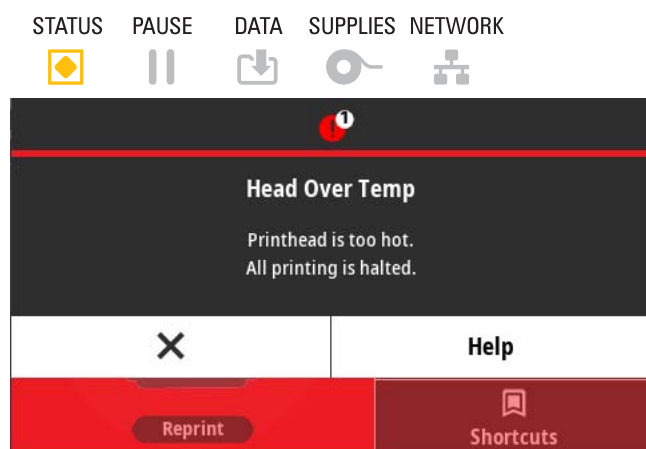

Possible Cause - 1

The printer is printing a large batch job, typically with large amounts of print.

Resolution

The print operation will resume after the printhead has cooled.

Possible Cause - 2

The ambient temperature at the printers location exceeds the specified operating range. Sometimes, ambient temperatures in the printer can be higher if it is in direct sunlight.

Resolution

Move the printer location or cool ambient temperature where the printer is operating.

Alert: PRINTHEAD SHUTDOWN

The printhead is below operating temperature for proper printing.

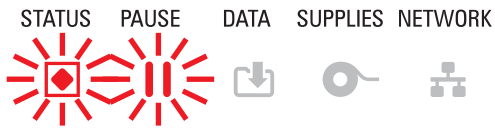

Possible Cause - 1

Printhead has had a critical current or power failure

Resolution

1. Turn the printer off by holding the power using the POWER button down for 5 seconds. Wait for the printer to shutdown completely. Turn the printer on.
2. If the printer does not recover from this error, call a service technician. This is not a operator serviceable item.

Alert: PRINTHEAD UNDER TEMP

The printhead is below operating temperature for proper printing.

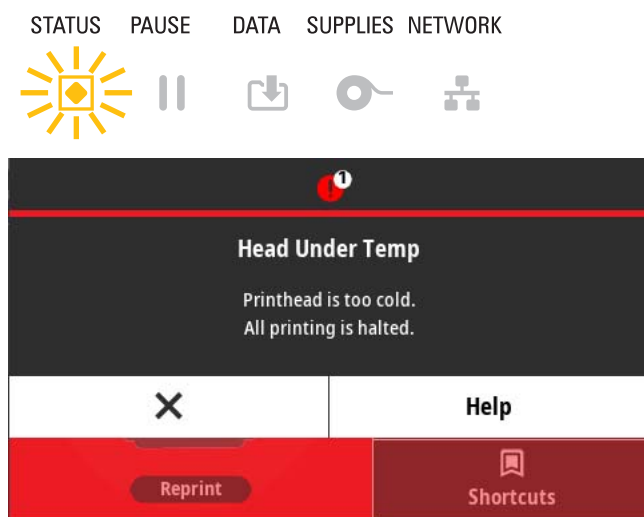

Possible Cause - 1

The ambient temperature at the printers location is below the specified operating range.

Resolution

Turn the printer off. Move the printer location and wait for it to warm naturally. Moisture may condense in and on the printer if the temperature changes too quickly.

Possible Cause - 2

The printhead thermistor has failed.

Resolution

1. Turn the printer off by holding the power button down for 5 seconds. Wait for the printer to shutdown completely. Turn the printer on.
2. If the printer does not recover from this error, call a service technician.

Alert: OUT OF MEMORY

Data can not be stored in the specified memory location. There are four types of storage memory: Graphic, Format, Bitmap and Font. There is not enough memory to perform the function specified on the second line of the error message.

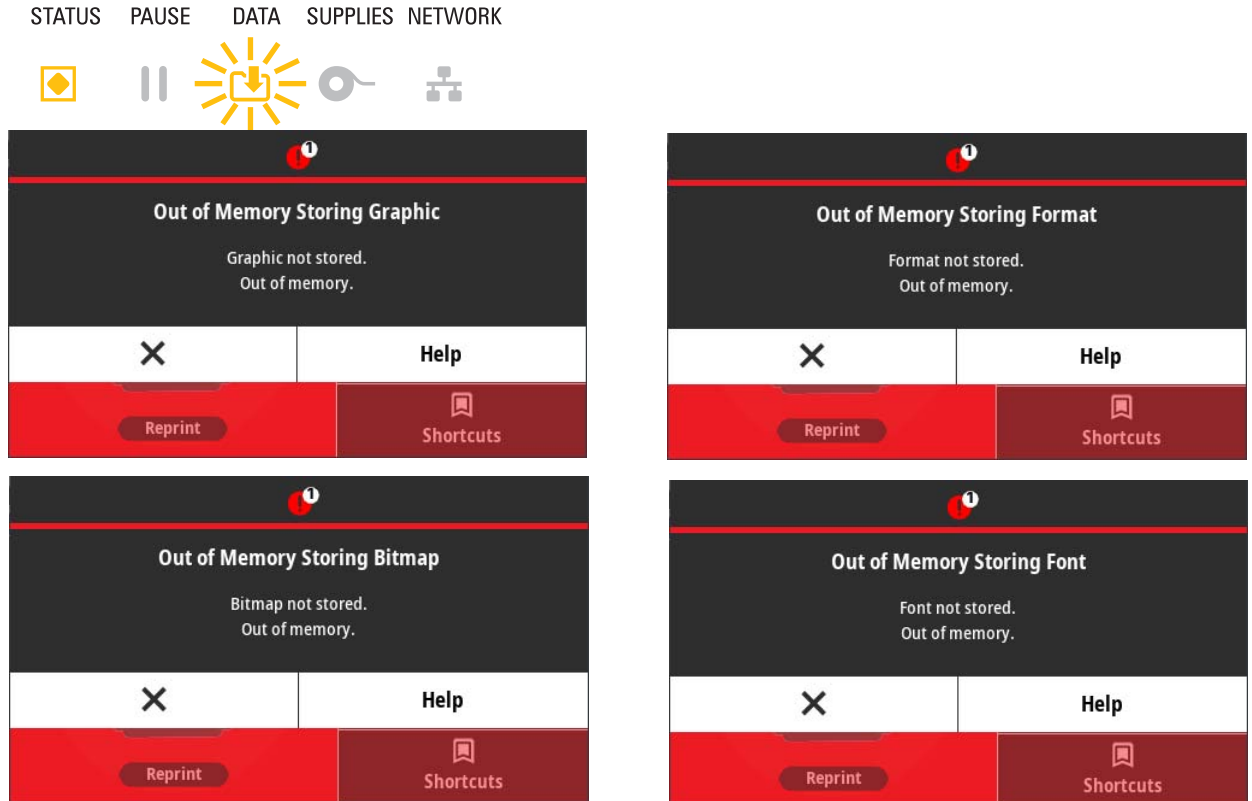

Possible Cause - 1

There is not enough memory to perform the function specified on the second line of the error message.

Resolution

1. Free up some of the printer's memory by adjusting the label format or printer parameters to make the print area smaller.
2. Remove unused graphics, fonts, or formats.
3. Ensure that the data is not directed to a device that is not installed or is unavailable.

Resolving Print Issues

This section helps you identify issues with printing or print quality, the possible causes, and the recommended solutions.

Issue: General Print Quality Issues

The printed image does not look right.

Possible Cause - 1

The printer is set at an incorrect darkness level and/or print speed.

Resolution

Perform the Print Quality Report (FEED self test) to determine the ideal darkness and speed settings for your application. Do not set print speeds above the manufacturer's maximum rated speed for your media (print material and ribbons both). Go to [Print Quality Report \(FEED self test\) on page 296](#) and [Adjusting the Print Quality on page 209](#).

Possible Cause - 2

The printhead is dirty.

Resolution

Clean the printhead. Go to [Cleaning the Printhead on page 243](#).

Possible Cause - 3

The platen roller is dirty or damaged.

Resolution

Clean or replace the platen. Platens can wear out or get damaged. Go to [Platen Cleaning and Replacement on page 255](#).

Possible Cause - 4

The printhead has worn out.

Resolution

Replace the printhead. The printhead can wear out and be damaged. Go to [Replacing the Printhead on page 259](#).

Possible Cause - 5

Thermal Transfer printing - Printing looks fuzzy, has smudge marks, or has voids or holes in print with no particular pattern.

Resolution

The print material (wax, wax-resin, or resin) may not match the material (paper, media coating, or synthetics) in use. Set the printer for no higher than the maximum recommended print speed of the ribbon cartridge. Go to [Ribbon Cartridge Programming Commands on page 218](#) for reading cartridge features.

Possible Cause - 6

You may be using the wrong power supply.

Resolution

Verify you are using the power supply that came with this printer.

Issue: No Print on the Label

The printed image does not look right.

Possible Cause - 1

The media may not be direct thermal media (and is thermal media made for thermal transfer printers).

Resolution

Go to the test procedure [Determining Thermal Media Types on page 334](#).

Possible Cause - 2

Media has been loaded incorrectly.

Resolution

The media printable surface must face up towards the printhead. Go to [Getting Ready to Print on page 157](#) followed by [Loading Roll Media on page 158](#).

Issue: Labels Are Distorted in Size or Print Area Start Position Varies

Includes printed image that skips between labels (mis-registration).

Possible Cause - 1

Media has been loaded incorrectly or the movable media sensor is not set properly.

Resolution

Verify that the sensor is set and positioned correctly for your media type and sensing location. Go to [Loading Roll Media on page 158](#), [Setting Media Sensing by Media type on page 158](#), and [Using the Movable Sensor on page 162](#).

Possible Cause - 2

The media sensors are not calibrated for your media length, physical properties, or sensing type (gap/notch, continuous, or mark).

Resolution

Go to [Run a SmartCal Media Calibration on page 177](#). or if it still skips labels try a [Manual Media Calibration on page 303](#).

Possible Cause - 3

The platen (drive) roller is slipping or damaged.

Resolution

Clean or replace the platen. Platens can wear out or get damaged. Go to [Platen Cleaning and Replacement on page 255](#).

Possible Cause - 4

The printer has communication issues with cables or communication settings.

Resolution

Go to [Communication Issues on page 288](#).

Communication Issues

This section identifies problems with communications, the possible causes, and the recommended solutions.

Issue: Label Job Sent, No Data Transfer

A label format was sent to the printer but was not recognized. The DATA light does not flash.

Possible Cause

The communication parameters are incorrect.

Resolution - 1

Check the printer driver or software communications settings (if applicable).

Resolution - 2

Serial Port Only - Check the printer's handshake protocol and serial port settings. The setting used must match the one being used by the host computer. Go to [Serial Interface on page 183](#) for the printer's default serial port settings.

Resolution - 3

The serial cable you are trying to use may not be a standard DTE or DCE type cable, is damaged, or is too long per the RS-232 Serial ports specifications. Go to [Serial Port Interface on page 308](#).

Issue: Label Job Sent, Skips Labels or Prints Bad Content

A label format was sent to the printer. Several labels print, then the printer skips, misplaces, misses, or distorts the image on the label.

Possible Cause

The serial communication settings are incorrect.

Resolution - 1

Check the printer driver or software communications settings (if applicable). Ensure that the flow control settings and other serial port handshake setting match the host system.

Issue: Label Job Sent, Data Transfers, But No Print

A label format was sent to the printer but was not recognized. The DATA light flashes but no printing occurs.

Possible Cause - 1

The prefix and delimiter characters set in the printer do not match the ones in the label format.

Resolution

Verify the ZPL command prefix (COMMAND CHAR) and delimiter (DELIM./CHAR) characters. [Configuration Setting to Command Cross-reference on page 341.](#)

Possible Cause - 2

Incorrect data is being sent to the printer.

Resolution

Check the communication settings on the computer. Ensure that they match the printer settings.

Possible Cause - 3

Incorrect data is being sent to the printer.

Resolution

Check the label format. Refer to the ZPL Programming Guide for details on printer programming. For printer links to manuals, go to [About on page 11.](#)

Miscellaneous Issues

This section identifies miscellaneous issues with the printer, the possible causes, and the recommended solutions.

Issue: Settings are Lost or Ignored

Some parameters are set incorrectly.

Possible Cause - 1

Printer settings were changed without saving them.

Resolution

The ZPL `^JU` command was not used to save your configuration before turning the printer off. Cycle the printer OFF and then back ON to verify settings have been saved.

Possible Cause - 2

The label format/form commands or commands sent directly to the printer have syntax errors or have been used incorrectly.

- A firmware command turned off the ability to change the parameter.
- A firmware command changed the parameter back to default setting.

Resolution

Refer to the ZPL programmer's guide to verify command usage and syntax. Go to [About on page 11](#) for support links to view the ZPL Programming Guide for your printer model.

Possible Cause - 3

The prefix and delimiter characters set in the printer do not match the ones in the label format.

Resolution

Verify the ZPL programming settings of the Control, Command and Delimiter settings are correct for your system software environment. Print a Configuration Report or use the display Language Menu (if present) for these three (3) menu items and compare it the commands in label format/form you are trying to print. Go to [Test Printing with the Configuration Report on page 178](#), [System > Language on page 76](#), and [ZPL Configuration on page 339](#).

Possible Cause - 4

The Main Logic board may not be working properly. Firmware is corrupted or the printer needs service.

Resolution

1. Reset the printer to factory defaults. Go to [System > Settings > Restore Defaults on page 86](#) or use the Zebra Setup Utility and **Open Printer Tools > Action > Load printer defaults**.
2. Reload printer firmware. Go to [Updating Printer Firmware on page 273](#).
3. If the printer does not recover from this error, call a service technician. This is not a user serviceable item.

Issue: Non-continuous labels act as Continuous labels.

A non-continuous label format with matching media loaded in the printer, was sent to the printer but prints like it is continuous media.

Possible Cause - 1

The printer was not calibrated for the media being used.

Possible Cause - 2

The printer is configured for continuous media.

Resolution

Set the printer for the correct media type (gap/notch, continuous, or mark) and calibrate the printer using [Run a SmartCal Media Calibration on page 177](#), if necessary use [Manual Media Calibration on page 303](#) for hard to calibrate media types. Go to [Print > Print Quality > Label Type on page 121](#) for ZD621 printers with the display to check and set media type.

Issue: Printer Locks-Up

All indicator lights are on and the printer locks up or the printer locks up while restarting.

Possible Cause - 1

The printer memory has been corrupted by an unknown event.

Resolution - 1

1. Reset the printer to factory defaults. Go to [System > Settings > Restore Defaults on page 86](#) or use the Zebra Setup Utility and **Open Printer Tools > Action > Load printer defaults**.
2. Reload printer firmware. Go to [Updating Printer Firmware on page 273](#).
3. If the printer does not recover from this error, call a service technician. This is not a user serviceable item.

Issue: Erroneous Ribbon Cartridge Faults

1. **Ribbon Out** warning, but a ribbon cartridge is installed.
2. **Ribbon Cartridge Authentication** error, but a Genuine Zebra Ribbon Cartridge is installed and has not been refurbished or altered.

Possible Cause

The Ribbon Cartridge Sensor Contact Pins or the Ribbon Cartridge's Smart Chip's contacts may be dirty or the chip may be damaged.

Resolution

1. Clean the ribbon cartridge's smart chip contact, if they look contaminated, with alcohol and a lightly moistened cotton. Try a different cartridge if this does not work.
2. Clean the Ribbon Cartridge Sensor Contact Pins - go to [Cleaning Ribbon Cartridge Sensor on page 254](#).

3. Reload printer firmware. Go to [Updating Printer Firmware on page 273](#).
4. If the printer does not recover from this error, call a service technician. This is not a user serviceable item.

Issue: Battery has a Red Indicator

Battery has a fault.

Possible Cause - 1

The battery has reached its usable life or has a general component failure.

Possible Cause - 2

Battery is too hot or too cold

Resolution

1. Remove the battery from the printer and check charge status by charging the battery.
2. Let the battery cool down or warm up to ambient temperature and recheck the battery charge.
3. Replace the battery.

Tools

This section provides a variety of tools and utilities built into your printer. They are designed to assist you with setup, configuration, and debugging (printer and command programming)

Printer Diagnostics

Diagnostic reports, calibration procedures, restoring factory defaults, and other diagnostics provide specific information about the condition of the printer.



IMPORTANT: Use full-width media when performing self tests. If your media is not wide enough, the test labels may print on the platen (drive) roller.



NOTE: Diagnostic Testing Tips:

- When performing these self tests, do not send data to the printer from the host. If your media is shorter than the label to be printed, the test label continues on the next label.
- When canceling a self test prior to completion, always reset the printer by turning it OFF and then ON.
- If the printer is in dispense mode and the liner is being taken up by the applicator, the operator must manually remove the labels as they become available.

Each self test is enabled by pressing a specific user interface button or combination of buttons while turning ON the printer power. Keep the button(s) pressed until the first indicator light turns off. The selected self test automatically starts at the end of the Power-On Self Test.

Power-On Self Test

A Power-On Self Test (POST) is performed each time the printer power is turned ON. During this test, the control panel indicators turn on and off to ensure proper operation. At the end of this self test, only the STATUS indicator remains lit.

SmartCal Media Calibration

SmartCal is used to quickly calibrate the printer to the media currently loaded. During SmartCal, the printer will automatically determine the media sensing type (gap, black line or notch) and then measure the length of the media.

To activate Smart Calibration, complete these steps:

1. Make sure media is properly loaded, the printer cover is closed, and printer power is ON.
2. Press and hold PAUSE + CANCEL buttons for two seconds.

- The printer will FEED and measure several labels. When done, the printer will return to READY status. If the printer should fail to recognize and correctly calibrate to the media, please refer to the [Manual Media Calibration](#) procedure later in this section.

Configuration Report (CANCEL Self Test)

The Configuration Report diagnostic prints a set of printer and network configuration reports.

To print the configuration report, complete these steps:

- Make sure media is loaded, the printer cover is closed, and printer power is ON.
- If printer power is OFF, press and hold CANCEL button while turning the printer power ON. Hold CANCEL button down until the STATUS indicator is the only indicator lit.
- or -
If printer power is ON, press FEED + CANCEL for two seconds.
- The Printer and Network Configuration Reports (below) will be printed and the printer will return to READY status.

Sample Printer Configuration

PRINTER CONFIGURATION	
Zebra Technologies ZTC ZD620-203dpi ZPL 50J164202531	
+15.0.....	DARKNESS
LOW.....	DARKNESS SWITCH
8.0 IPS.....	PRINT SPEED
+000.....	TEAR OFF ADJUST
TEAR OFF.....	PRINT MODE
CONTINUOUS.....	MEDIA TYPE
TRANSMISSIVE.....	SENSOR SELECT
DIRECT-THERMAL.....	PRINT METHOD
830.....	PRINT WIDTH
2030.....	LABEL LENGTH
39.0 IN.....	MAXIMUM LENGTH
MAINT. OFF.....	EARLY WARNING
CONNECTED.....	USB COMM.
AUTO.....	SER COMM. MODE
9800.....	BAUD
8 BITS.....	DATA BITS
NONE.....	PARITY
XON/XOFF.....	HOST HANDSHAKE
NONE.....	PROTOCOL
NORMAL MODE.....	COMMUNICATIONS
<>> 7EH.....	CONTROL PREFIX
<>> 5EH.....	FORMAT PREFIX
<>> 2CH.....	DELIMITER CHAR
ZPL II.....	ZPL MODE
INACTIVE.....	COMMAND OVERRIDE
NO MOTION.....	MEDIA POWER UP
FEED.....	HEAD CLOSE
DEFAULT.....	BACKFEED
+000.....	LABEL TOP
DISABLED.....	REPRINT MODE
045.....	WEB SENSOR
096.....	MEDIA SENSOR
128.....	TAKE LABEL
062.....	MARK SENSOR
004.....	MARK MED SENSOR
046.....	TRANS GAIN
034.....	TRANS LED
049.....	MARK GAIN
100.....	MARK LED
DP05HFXM.....	MODES ENABLED
.....	MODES DISABLED
832 8/MM FULL.....	RESOLUTION
4.0.20.072P37536.....	LINK-OS VERSION
V84.20.072P37536.....	FIRMWARE
1.3.....	XML SCHEMA
6.5.0.0.770.....	HARDWARE ID
8152k.....	RAM
65536k.....	ONBOARD FLASH
NONE.....	FORMAT CONVERT
FW VERSION.....	IDLE DISPLAY
06/08/17.....	RTC DATE
07:07.....	RTC TIME
DISABLED.....	ZBI
2.1.....	ZBI VERSION
READY.....	ZBI STATUS
178 LABELS.....	NONRESET CNTR
178 LABELS.....	RESET CNTR1
178 LABELS.....	RESET CNTR2
1,290 IN.....	NONRESET CNTR
1,290 IN.....	RESET CNTR1
1,290 IN.....	RESET CNTR2
3,277 CM.....	NONRESET CNTR
3,277 CM.....	RESET CNTR1
3,277 CM.....	RESET CNTR2
002 WIRED.SERIAL.....	SLOT 1
0.....	MASS STORAGE COUNT
0.....	HID COUNT
OFF.....	USB HOST LOCK OUT
FIRMWARE IN THIS PRINTER IS COPYRIGHTED	

Sample Network Configuration

Network Configuration	
Zebra Technologies ZTC ZD620-203dpi ZPL 50J164202531	
Wired.....	PRIMARY NETWORK
PrintServer.....	LOAD LAN FROM?
WIRELESS.....	ACTIVE PRINTSRVR
Wired	
ALL.....	IP PROTOCOL
000.000.000.000.....	IP ADDRESS
000.000.000.000.....	SUBNET
000.000.000.000.....	GATEWAY
000.000.000.000.....	WINS SERVER IP
YES.....	TIMEOUT CHECKING
300.....	TIMEOUT VALUE
000.....	ARP INTERVAL
9100.....	BASE RAW PORT
9200.....	JSON CONFIG PORT
Wireless*	
ALL.....	IP PROTOCOL
172.029.016.028.....	IP ADDRESS
255.255.255.000.....	SUBNET
172.029.016.001.....	GATEWAY
172.029.001.003.....	WINS SERVER IP
YES.....	TIMEOUT CHECKING
300.....	TIMEOUT VALUE
000.....	ARP INTERVAL
9100.....	BASE RAW PORT
9200.....	JSON CONFIG PORT
02dFH.....	CARD INSERTED
9134H.....	CARD MFG ID
ac:3f:a4:b9:17:b8.....	CARD PRODUCT ID
.....	MAC ADDRESS
YES.....	DRIVER INSTALLED
INFRASTRUCTURE.....	OPERATING MODE
125.....	ESSID
18.0.....	CURRENT TX RATE
OPEN.....	WEP TYPE
NONE.....	WLAN SECURITY
1.....	WEP INDEX
000.....	POOR SIGNAL
LONS.....	PREAMBLE
YES.....	ASSOCIATED
ON.....	PULSE ENABLED
15.....	PULSE RATE
OFF.....	INTL MODE
USA/CANADA.....	REGION CODE
USA/CANADA.....	COUNTRY CODE
0x3FFFFFFF.....	CHANNEL MASK
Bluetooth	
4.3.1p1.....	FIRMWARE
02/13/2015.....	DATE
on.....	DISCOVERABLE
3.0/4.0.....	RADIO VERSION
on.....	ENABLED
ac:3f:a4:b9:17:b8.....	MAC ADDRESS
50J164202531.....	FRIENDLY NAME
no.....	CONNECTED
1.....	MIN SECURITY MODE
no.....	CONN SECURITY MODE
supported.....	iOS
FIRMWARE IN THIS PRINTER IS COPYRIGHTED	

Printer Network (and Bluetooth) Configuration Report

ZD-Series printers with Wired or Wireless connectivity options installed will print an additional printer configuration report. This information needed to establish and trouble shoot Ethernet (LAN and WLAN), Bluetooth 4.1 and Bluetooth LE network printing. The following printout is printed with the ZPL `~WL` command.

```

Network Configuration
Zebra Technologies
ZTC ZD620-203dpi ZPL
50J164202531

Wired..... PRIMARY NETWORK
PrintServer..... LOAD LAN FROM?
WIRELESS..... ACTIVE PRINTSRVR

Wired
ALL..... IP PROTOCOL
000.000.000.000... IP ADDRESS
000.000.000.000... SUBNET
000.000.000.000... GATEWAY
000.000.000.000... WINS SERVER IP
YES..... TIMEOUT CHECKING
300..... TIMEOUT VALUE
000..... ARP INTERVAL
9100..... BASE RAW PORT
9200..... JSON CONFIG PORT

Wireless*
ALL..... IP PROTOCOL
172.029.016.028... IP ADDRESS
255.255.255.000... SUBNET
172.029.016.001... GATEWAY
172.029.001.003... WINS SERVER IP
YES..... TIMEOUT CHECKING
300..... TIMEOUT VALUE
000..... ARP INTERVAL
9100..... BASE RAW PORT
9200..... JSON CONFIG PORT
INSERTED..... CARD INSERTED
02dFH..... CARD MFG ID
9194H..... CARD PRODUCT ID
ac:3f:a4:89:17:b8.. MAC ADDRESS
YES..... DRIVER INSTALLED
INFRASTRUCTURE... OPERATING MODE
125..... ESSID
18.0..... CURRENT TX RATE
OPEN..... WEP TYPE
NONE..... WLAN SECURITY
1..... WEP INDEX
000..... POOR SIGNAL
LONG..... PREAMBLE
YES..... ASSOCIATED
ON..... PULSE ENABLED
15..... PULSE RATE
OFF..... INTL MODE
USA/CANADA..... REGION CODE
USA/CANADA..... COUNTRY CODE
0x3FFFFFFF..... CHANNEL MASK

Bluetooth
4.3.1p1..... FIRMWARE
02/13/2015..... DATE
on..... DISCOVERABLE
3.0/4.0..... RADIO VERSION
on..... ENABLED
ac:3f:a4:89:17:b9.. MAC ADDRESS
50J164202531..... FRIENDLY NAME
no..... CONNECTED
1..... MIN SECURITY MODE
nc..... CONN SECURITY MODE
supported..... iOS

FIRMWARE IN THIS PRINTER IS COPYRIGHTED
  
```

iOS Support Setting

iOS Bluetooth Support

- iOS devices have Bluetooth Classic 4.X when the Wi-Fi and Bluetooth Classic wireless connectivity option is installed in your printer and is noted as 'supported' on the bottom of the Bluetooth Configuration report.
- The iOS setting is noted on the bottom of the Bluetooth Configuration report as 'not supported' when the wireless connectivity option is not installed.

Print Quality Report (FEED self test)

Different types of media may require different darkness settings. This section contains a simple but effective method for determining the ideal darkness for printing barcodes that are within specifications.

During the Print Quality Report (FEED self test), a series of labels are printed at different darkness settings at two different print speeds. The relative darkness and the print speed are printed on each label. The barcodes on these labels may be ANSI-graded to check print quality.

During this test, one set of labels is printed at low speed, and another set is printed at the high speed. The darkness value starts at three settings lower than the printer's current darkness value (relative darkness of -3) and increase until the darkness is three settings higher than the current darkness value (relative darkness of +3).

The speed at which labels are printed during this print quality test depends on the dot density of the printhead.

- 300 dpi printers: prints 7 labels at 51mm/sec (2 ips) and 102 mm/sec (4 ips) print speeds.
- 203 dpi printers: prints 7 labels at 51mm/sec (2 ips) and 152 mm/sec (6 ips) print speeds.

To perform a Print Quality Report, complete these steps:

1. Print a configuration report to show the printer's current settings. Press and hold the FEED and CANCEL buttons for two (2) seconds to print the report.
2. Turn OFF the printer.
3. Press and hold FEED while setting the printer power to ON. Hold FEED until the Status indicator is the only indicator lit.

The printer prints a series of labels (Figure 1) at various speeds and darkness settings higher and lower than the darkness value shown on the configuration label.

Figure 1 Print Quality Report



- See [Figure 2](#) and [Table 1](#). Inspect the test labels and determine which one has the best print quality for your application. If you have a barcode verifier, use it to measure bars/spaces and calculate the print contrast. If you do not have a barcode verifier, use your eyes or the system scanner to choose the optimal darkness setting based on the labels printed in this self test.

Figure 2 Barcode Darkness Comparison

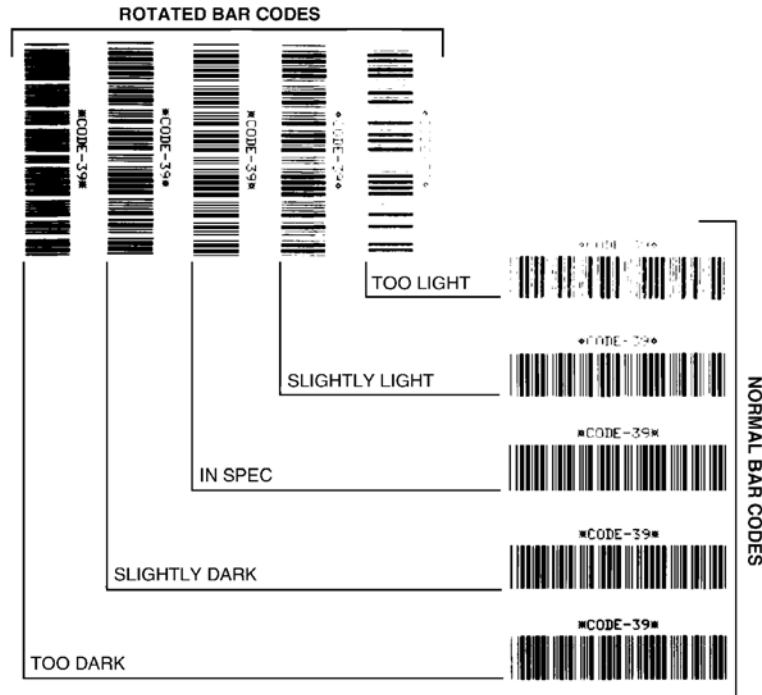

Table 1 Visual Darkness Descriptions

Print Quality	Description
Too dark	<ul style="list-style-type: none"> • Labels that are too dark are fairly obvious. They may be readable but not “in-spec.” • The normal barcode bars increase in size. • The openings in small alphanumeric characters may appear filled in. • Rotated barcode have bars and spaces run together.
Slightly dark	<ul style="list-style-type: none"> • Slightly dark labels are not as obvious. • The normal barcode will be “in-spec.” • Small character alpha numerics will be bold and could be slightly filled in. • The rotated barcode spaces are small when compared to the “in-spec” code, possibly making the code unreadable.
“In-spec”	<ul style="list-style-type: none"> • The “in-spec” barcode can only be confirmed by a verifier, but it should exhibit the following visible characteristics. • The normal barcode will have complete, even bars and clear, distinct spaces. • The rotated barcode will have complete, even bars and clear, distinct spaces. Although it may not look as good as a slightly dark barcode, the barcode will be “in-spec.” • In both normal and rotated styles, small alphanumeric characters look complete.
Slightly light	<ul style="list-style-type: none"> • Slightly light labels are, in some cases, preferred to slightly dark ones for “in-spec” barcodes. • Both normal and rotated barcodes will be in spec, but small alphanumeric characters may not be complete.
Too light	<ul style="list-style-type: none"> • Labels that are too light are obvious. • Both normal and rotated barcodes have incomplete bars and spaces. • Small alphanumeric characters are unreadable.

5. Note the relative darkness value and the print speed printed on the best test label.
6. Add or subtract the relative darkness value from the darkness value specified on the configuration label. The resulting numeric value is the best darkness value for that specific label/ribbon combination and print speed.
7. If necessary, change the current darkness value to the darkness value on the best test label.
8. If necessary, change the current print speed to the speed value on the best test label.

Reset Printer Factory Defaults (PAUSE + FEED Self Test)

This resets the printer configuration to the factory default values for the non-network printer settings. Perform a sensor calibration after this procedure. (Go to [Manual Media Calibration on page 303.](#))

To perform a Reset Printer Factory Defaults procedure, complete these steps:

1. Turn OFF the printer.
2. Press and hold PAUSE + FEED while turning ON the printer.
3. Hold PAUSE + FEED until the STATUS indicator () is the only indicator lit.

The printer configuration is reset to the factory default values. No labels print at the end of this action.



NOTE: The printer has a reset button under the printer, Go to [Reset Button on page 300.](#)

Reset Network Factory Defaults (PAUSE + CANCEL Self Test)

This procedure resets the network configuration settings only to the factory default values.

To perform a Reset Network Factory Defaults procedure, complete these steps:

1. Turn OFF the printer.
2. Press and hold PAUSE + CANCEL while turning ON the printer.
3. Hold PAUSE + CANCEL until the STATUS indicator () is the only indicator lit.

The printer's network configuration is reset to the factory default values. No labels print at the end of this action.

Reset Button

In addition to the power on configurations described previously, the ZD-Series printer has a dedicated reset button located on the bottom of the printer which can be pressed with a paperclip or similar small object.

Pressing the button has the following results based on the length of the button press:

0-1 second	No action
1-5 seconds	Printer reset – Printer performs a factory reset and will automatically print a configuration label (and network label if present)
6-10 seconds	Network reset – Printer drops connection to the network, and a network factory default reset occurs. Upon completion of the reset, a configuration and network configuration label are automatically printed.
More than 10 seconds	Exits the factory defaults function without resetting the printer or making changes

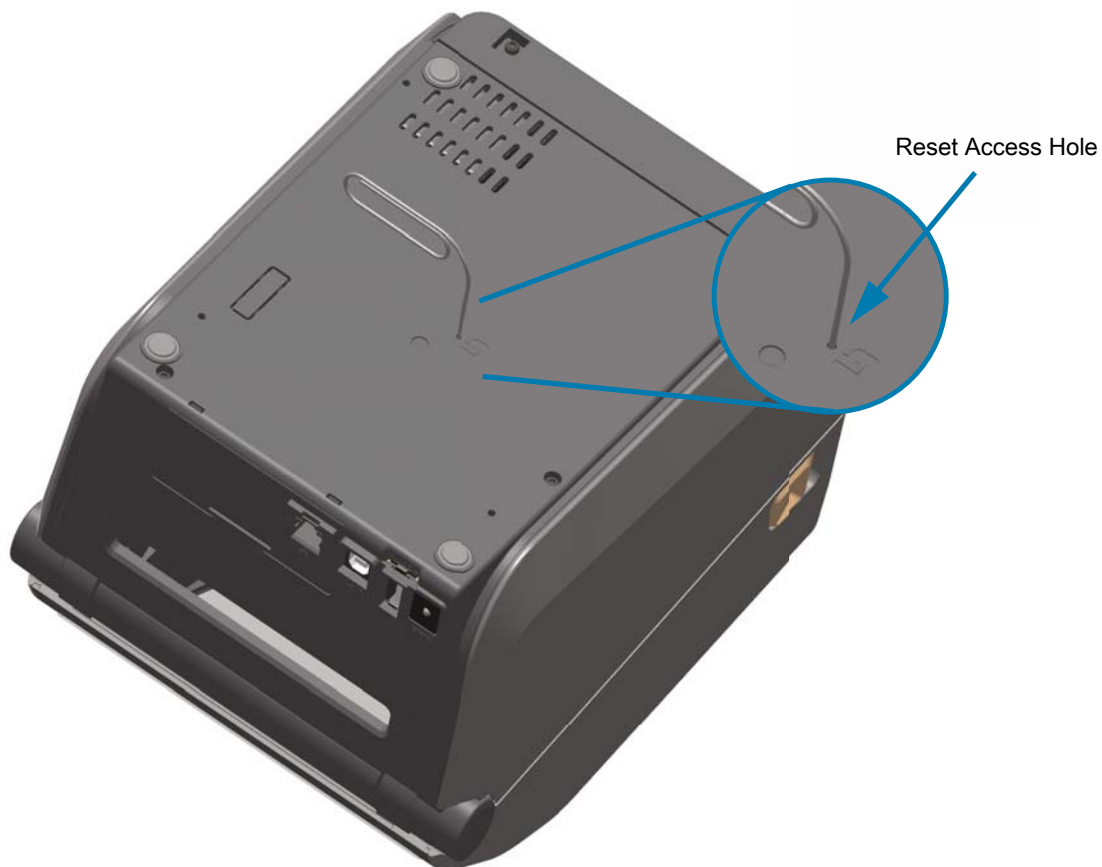

Communication Diagnostics Test

The communication diagnostics test is a troubleshooting tool for checking the connection between the printer and the host computer. When the printer is in diagnostics mode, it prints all data received from the host computer as straight ASCII characters with the hex values below the ASCII text. The printer prints all characters received, including control codes such as CR (carriage return). [Figure 3](#) shows a typical test label from this test.



NOTE: The test label prints upside-down as it exits the printer.

Figure 3 Communications Diagnostics Test Label

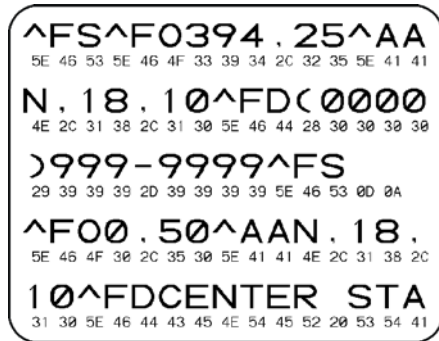

To use communications diagnostics mode, complete these steps:

1. Ensure media is loaded and printer power is ON.
2. Set the print width equal to or less than the label width being used for the test.
3. Press and hold Pause + FEED for two seconds. When active, the STATUS indicator will alternate between green and yellow.
The printer enters diagnostics mode and prints any data received from the host computer on a test label.
4. Check the test label for error codes. For any errors, check that your communication parameters are correct.
Errors show on the test label as follows:
 - **FE** indicates a framing error.
 - **OE** indicates an overrun error.
 - **PE** indicates a parity error.
 - **NE** indicates noise.
5. Press and hold Pause + FEED for two seconds or turn the printer power off (O) and then back ON to exit this self test and return to normal operation.

Sensor Profile

Use the sensor profile image (which will extend across several labels or tags) to troubleshoot the following situations:

- The printer experiences difficulty in determining gaps (web) between labels.
- The printer incorrectly identifies preprinted areas on a label as gaps (web).
- The printer cannot detect ribbon.

With the printer in the Ready state, print a sensor profile in one of these ways:

<p>Using the buttons on the user interface</p>	<ol style="list-style-type: none"> 1. Turn OFF the printer. 2. Press and hold FEED + CANCEL while turning ON the printer. 3. Hold FEED + CANCEL until the STATUS indicator is the only indicator lit.
<p>Using ZPL</p>	<p>Send the ~JG command to the printer. Refer to the Zebra Programming Guide for more information about this command.</p>

Compare your results to the examples shown earlier in this section. If the sensitivity of the sensors must be adjusted, calibrate the printer (go to [Manual Media Calibration on page 303](#)).

Media Sensor Profile (Figures 5 and 6)

The line labeled MEDIA (1) on the sensor profile indicates the media sensor readings. The media sensor threshold settings is indicated by WEB (2). The media out threshold is indicated by OUT (3). The upward spikes (4) indicate gaps between labels (the web), the lines between the spikes (5) indicate where labels are located, and the numbered line at the top (6) provides measurement in dots from the start of the printout.

If you compare the sensor profile printout to a length of your media, the spikes should be the same distance apart as the gaps on the media. If the distances are not the same, the printer may be having difficulty determining where the gaps are located.

Figure 4 Sensor Profile (Gap Media)

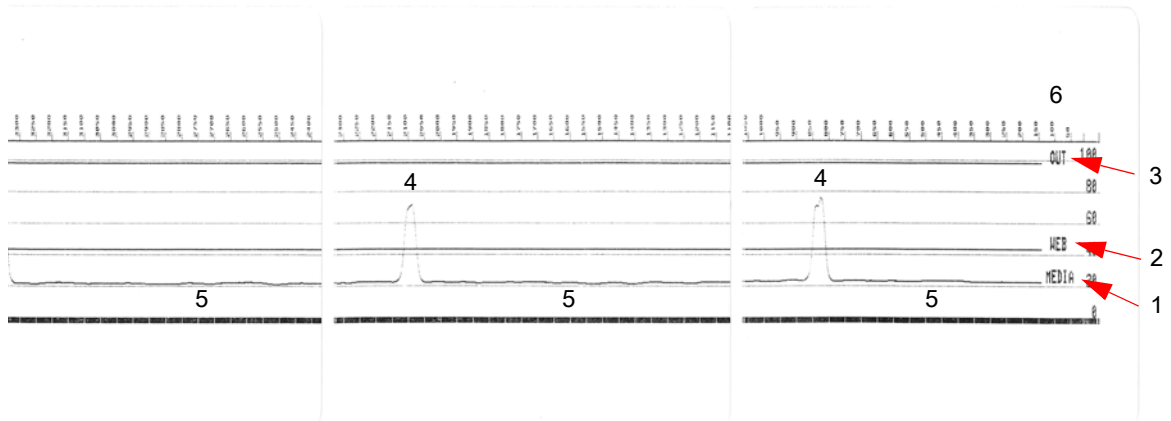
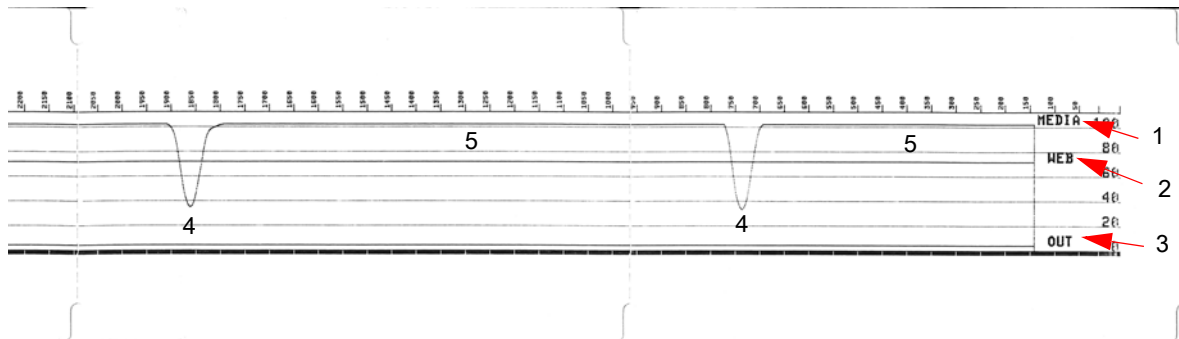

Figure 5 Sensor Profile (Black Mark Tag Media)

Advanced Mode

Advanced Mode is used to access several manual adjustment modes in the printer. Each manual adjustment mode is described in detail in the following sections.

To activate Advanced Mode, complete these steps:

1. Ensure media is loaded and printer power is ON.
2. Press PAUSE for two seconds, all indicators will flash yellow.
3. The STATUS indicator will show solid yellow, indicating the currently selected mode is: Manual Media Calibration.
4. Pressing FEED will sequentially cycle through all available modes.
5. Pressing PAUSE will activate the selected mode.
6. Pressing CANCEL will exit Advanced Mode.

Manual Media Calibration

While in Advanced Mode, pressing PAUSE while the Status indicator is illuminated yellow will start Manual Media Calibration.

1. The MEDIA indicator will flash yellow then the Pause indicator will flash. Open the printer and verify the media sensor is in the center position for label gap (transmissive) sensing. Remove 3 in. or 80mm of labels from the liner. Place the label-less area of the liner over the platen (drive) roller with the leading edge of the first label under the media guides.
2. Close the printer and press PAUSE once. The MEDIA indicator will flash as the media liner is measured. When complete, the Pause indicator will begin flashing.
3. Open the printer and reposition the media so that a label is located directly above the movable sensor. Close the printer.
4. Press PAUSE once. The printer will FEED and measure several labels. If the printer is able to determine the correct media type (gap, black mark or notch) and measure the media length, the printer will return to the READY state.

This advanced mode is typically used to calibrate the printer to media that is not correctly recognized during Smart Calibration. If your media uses black mark or notch sensing, ensure the media sensor is in to the proper location to “see” the mark or notch. If your media is pre-printed, either on the front of the label or on the back of the liner, position the sensor so that it is in a position with minimal printing. You may need to perform Manual Media Calibration several times, moving the media sensor, until the printer completes the calibration process and returns to the READY state.

Manual Print Width Adjustment

While in Advanced Mode, pressing the PAUSE button while the Pause indicator is illuminated yellow will start Manual Print Width Adjustment while in Advanced mode, go to [Advanced Mode on page 303](#). The printer will print a 16mm (0.63 in.) box and pause momentarily. The printer will then print a slightly larger box and again pause. When you see the printer print a box that matches the width of your media, press FEED to set the print width and return to READY state.

To return to the maximum print width setting, allow the printer to proceed without pressing the FEED button.

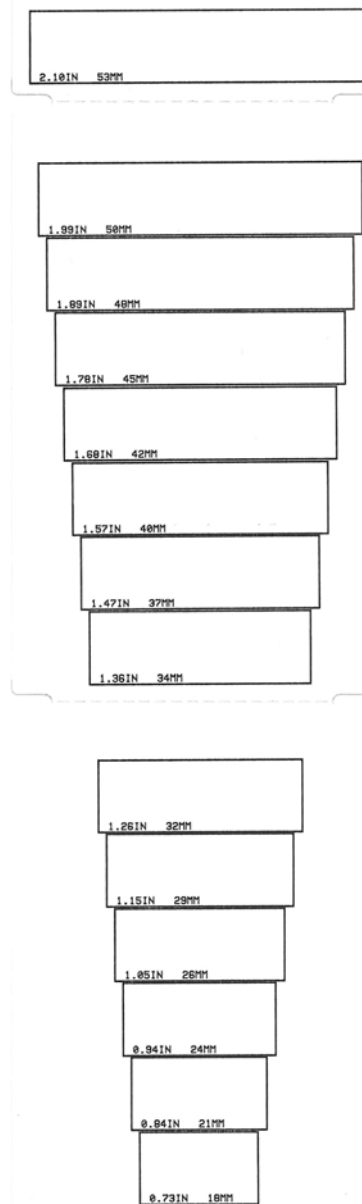

Manual Print Darkness Adjustment

Pressing PAUSE while the DATA indicator () is illuminated yellow will start Manual Print Darkness Adjustment. The printer will print a test pattern showing the current darkness number and several barcode patterns and then pause momentarily. The printer will then repeat the pattern with the next darkness level. When you see the printer print a pattern with solid even black lines, press FEED to set the darkness value and return to the READY state.



Factory Test Modes

The printer includes print modes that are intended for factory test only.

Test mode 1

Initiated by holding PAUSE button while turning ON printer power. When activated, the printer will begin printing various test patterns used to evaluate printer performance.

Test mode 2

Initiated by holding PAUSE + FEED + CANCEL button for two seconds while printer power is ON. When activated, the printer will begin printing various test patterns used to evaluate printer performance.



NOTE: Both of these test modes will consume a considerable amount of media as the tests are performed.

You can exit either of these test modes by pressing and holding POWER button until the printer power is switched OFF.

Interface Wiring

Universal Serial Bus (USB) Interface

The figure below displays the cable wiring required to use the printer's USB two interfaces.



IMPORTANT: When using third party cables, the printer requires USB cables or the cable packaging that bears the “Certified USB™” mark to guarantee USB 2.0 compliance.

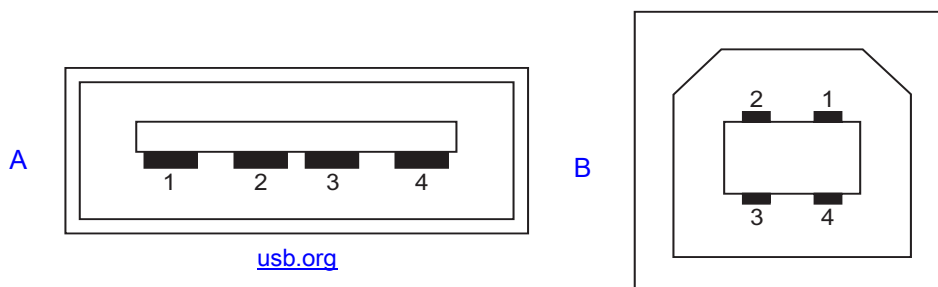

Wiring - USB Connector “A” Style for “connecting to” the printer or device

Pin 1 — Vbus (+5VDC). (Pin 2 — D- (Data Signal, Negative Side)
Pin 3 — D+ (Data Signal, Positive Side)
Pin 4 — Shell (Shield/Drain Wire) Shell

Wiring - USB Connector “B” Style for “connecting to” the printer or device

Pin 1 — Vbus (Not Connected)
Pin 2 — D- (Data Signal, Negative Side)
Pin 3 — D+ (Data Signal, Positive Side)
Pin 4 — Shell (Shield/Drain Wire) Shell



IMPORTANT: USB Host +5 VDC power source is shared with serial port phantom power. It is limited to 0.5mA per USB Specification and with on-board current limiting. The maximum current available through the serial port and USB port will not exceed a total of 0.75 Amps.

Serial Port Interface

Zebra Auto-Detecting DTE and DCE for 9-Pin RS-232 Interface

Pin	DTE	DCE	Description (DTE)
1	—	5V	Not used
2	RXD	TXD	RXD (receive data) input to the printer
3	TXD	RXD	TXD (transmit data) output from the printer
4	DTR	DSR	DTR (data terminal ready) output from the printer -- controls when the host may send data
5	GND	GND	Circuit ground
6	DSR	DTR	DSR (data set ready) input to the printer
7	RTS	CTS	RTS (request to send) output from the printer -- always in the ACTIVE condition when the printer is turned on
8	CTS	RTS	CTS (clear to send) - Not used by the printer
9	5V	—	+5 V @ 0.75 A - FET Circuit current limited



IMPORTANT: The maximum current available through the serial port, USB port or both will not exceed a total of 0.75 Amps.

When XON/XOFF handshaking is selected in the printer driver, data flow is controlled by the ASCII control codes DC1 (XON) and DC3 (XOFF). The DTR control lead will have no effect.

Connecting the Printer to a DTE Device

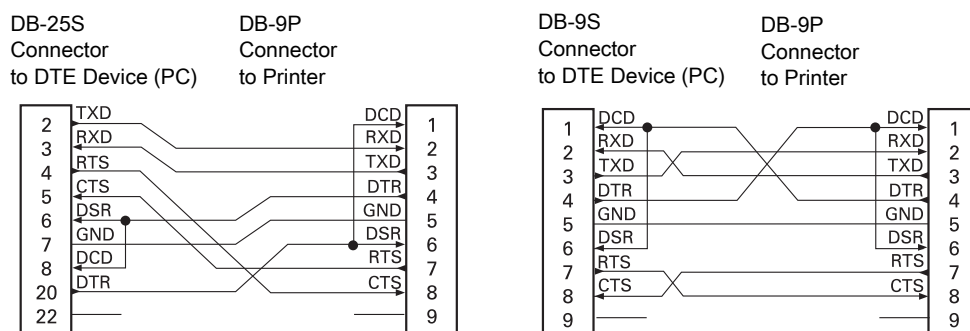

Interconnecting to DTE Devices — The printer is configured as data terminal equipment (DTE). To connect the printer to other DTE devices (such as the serial port of a personal computer), use an RS-232 null modem (crossover) cable.

Connecting the Printer to a DCE Device

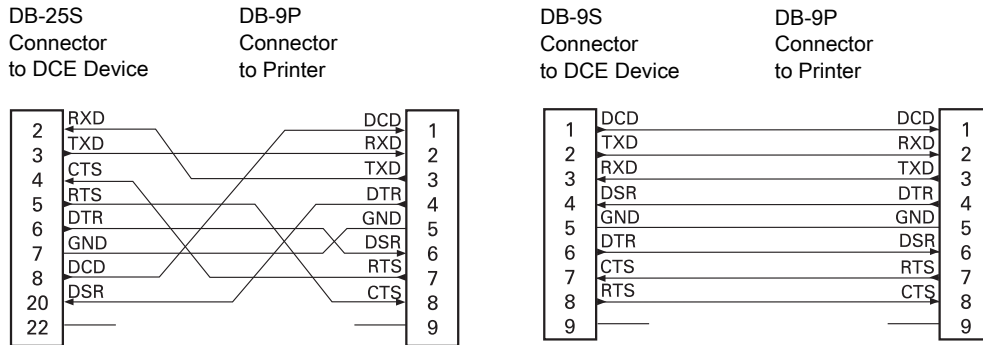

Interconnecting to DCE Devices — When the printer is connected via its RS-232 interface to data communication equipment (DCE) such as a modem, a STANDARD RS-232 (straight-through) interface cable must be used.

Dimensions

This section provides external printer dimensions for the following printers:

- [ZD621 / ZD421 Thermal Transfer Models on page 311.](#)
- [ZD421 Ribbon Cartridge Thermal Transfer Models on page 319.](#)
- [ZD621 / ZD421 Direct Thermal Models on page 327.](#)

ZD621 / ZD421 Thermal Transfer Models

All dimension are in millimeters

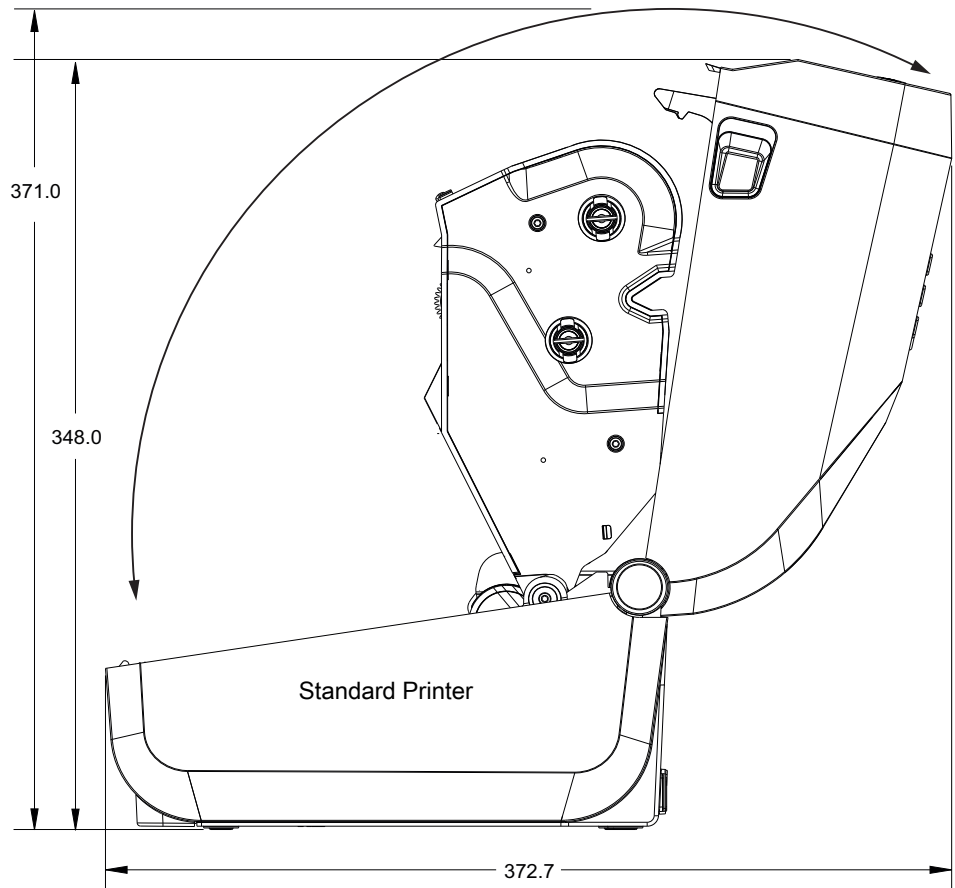
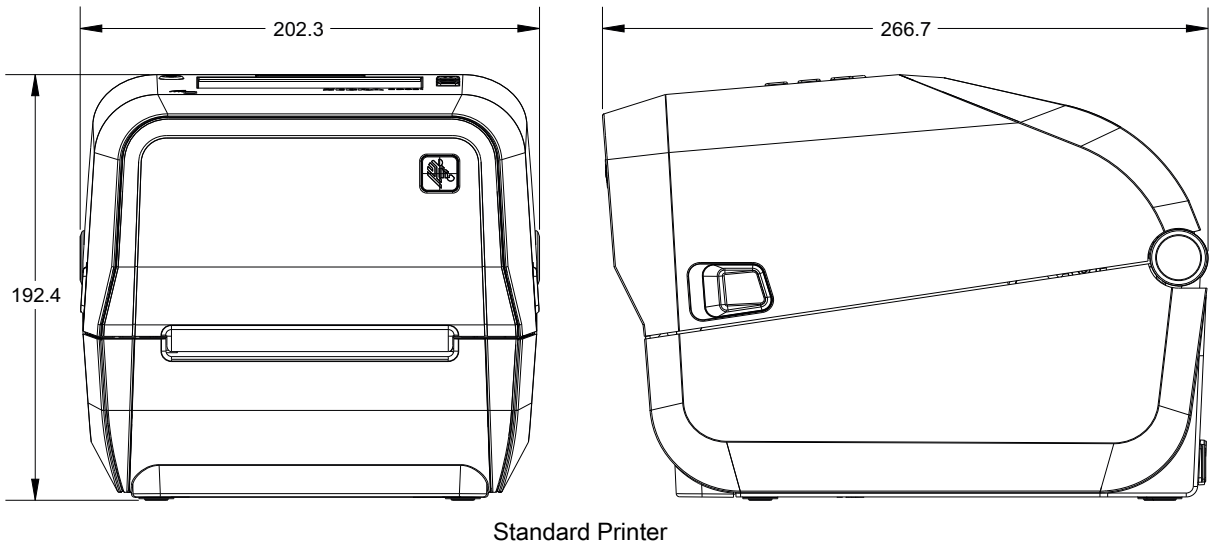

ZD621 / ZD421 Thermal Transfer Models

All dimension are in millimeters

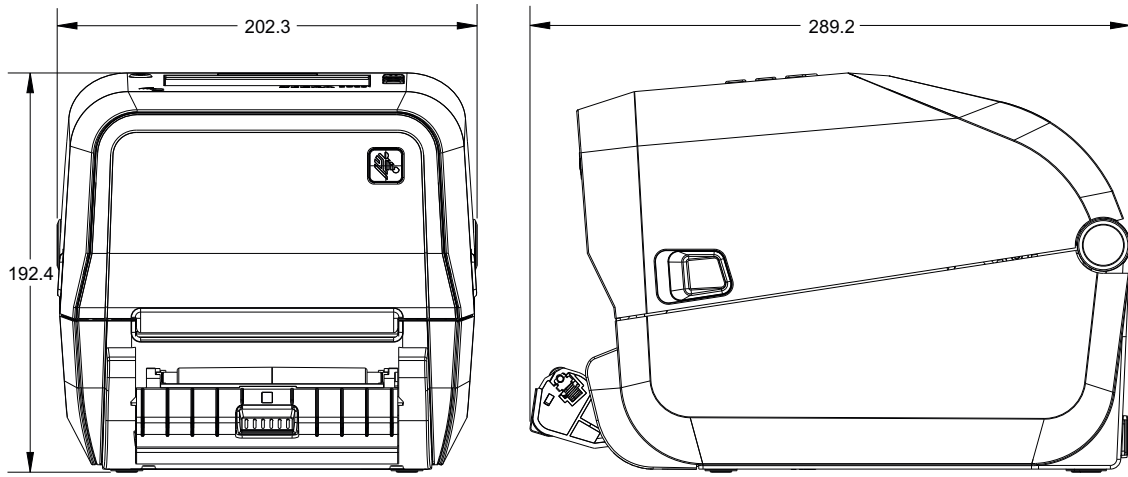

Printer with Label Dispenser (open)

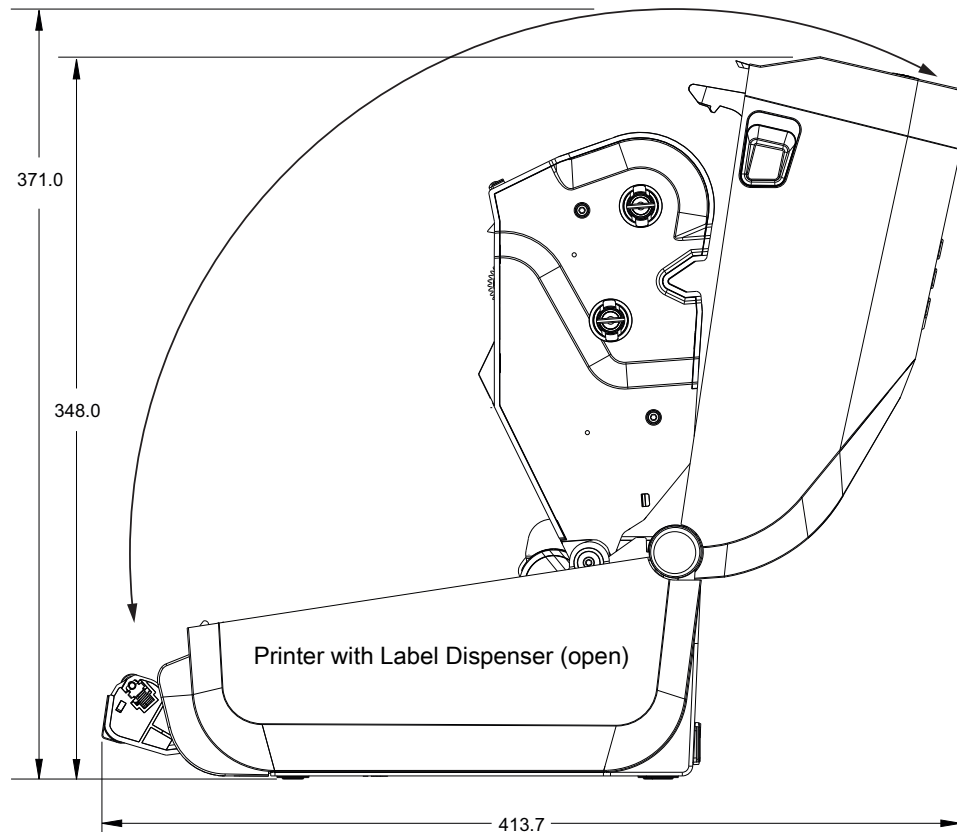

ZD621 / ZD421 Thermal Transfer Models

All dimension are in millimeters

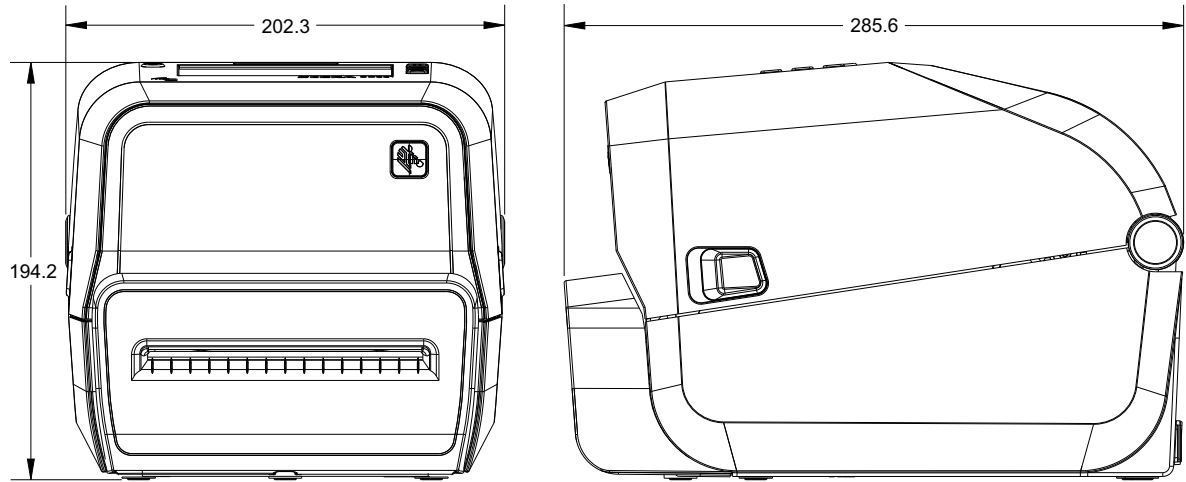

Printer with Cutter

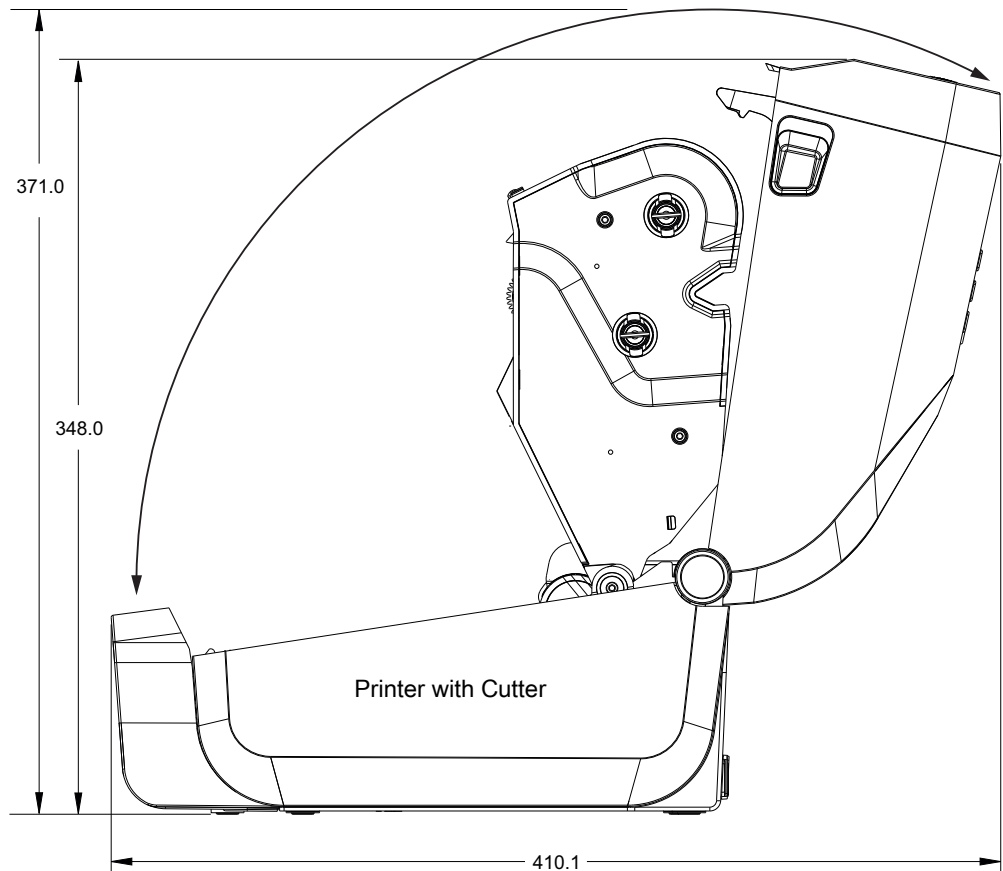

Dimensions

ZD621 / ZD421 Thermal Transfer Models

All dimension are in millimeters

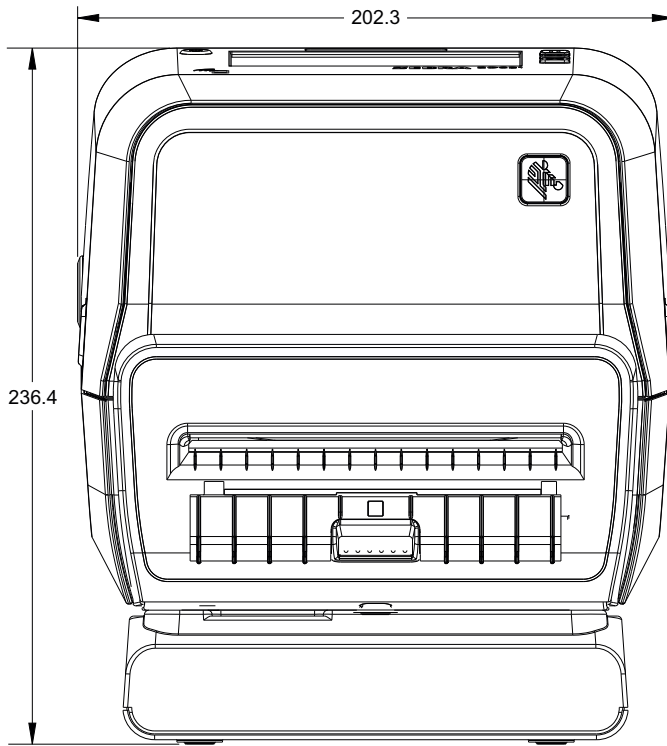

Printer with Attached Power Supply Base

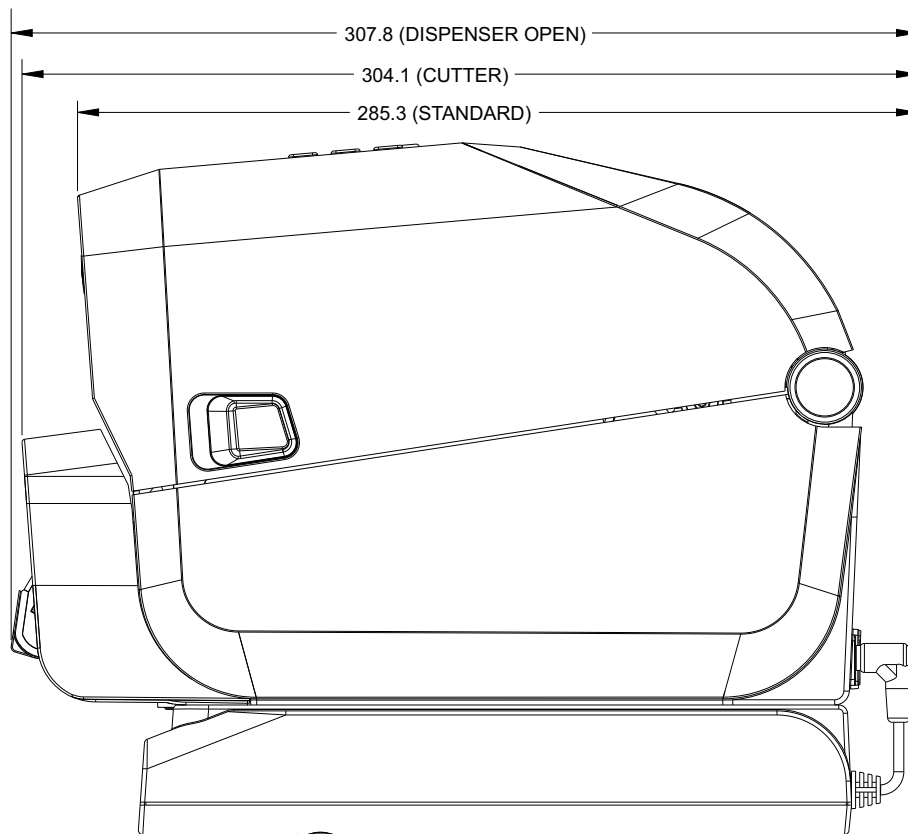

ZD621 / ZD421 Thermal Transfer Models

All dimension are in millimeters

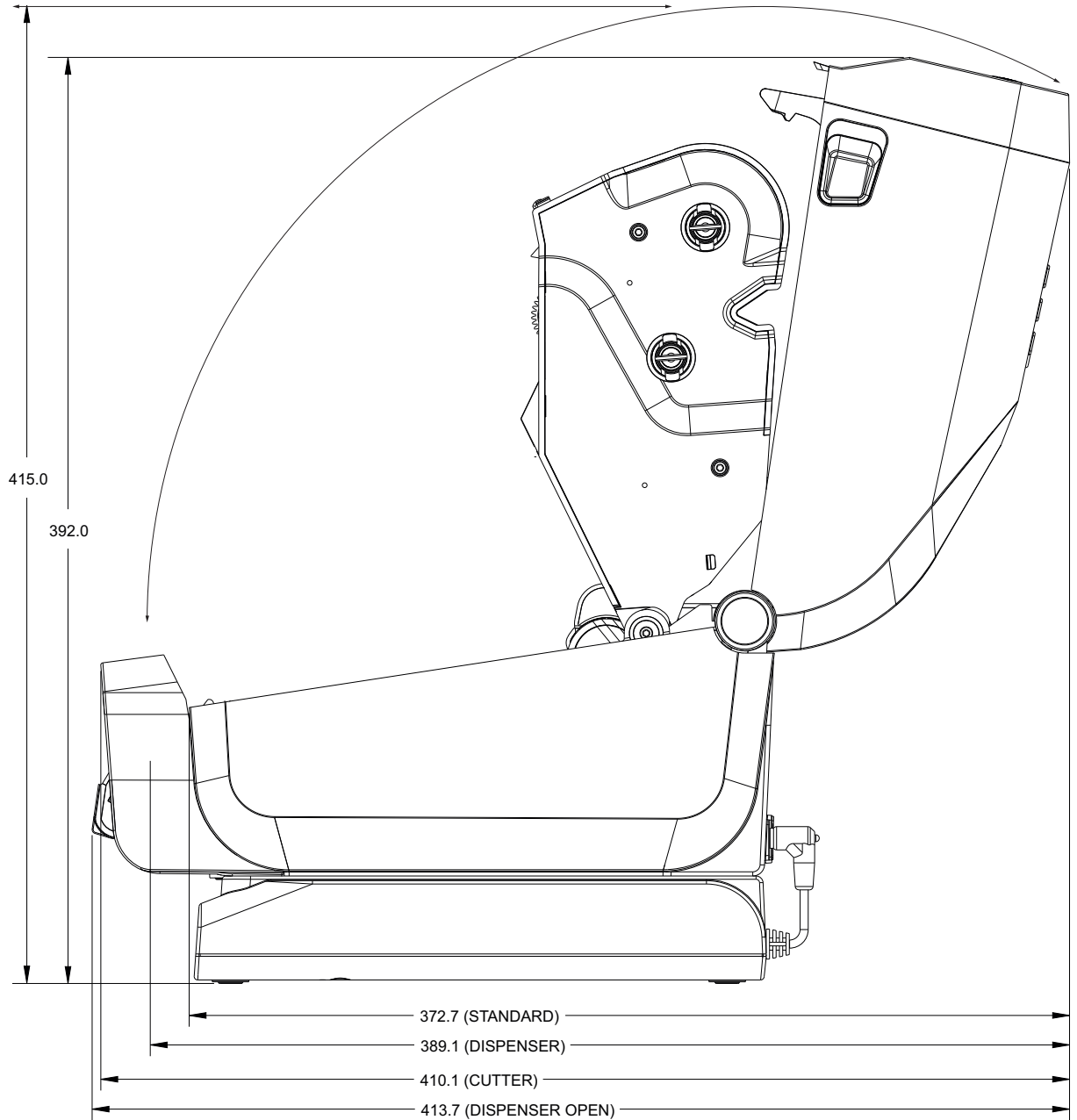

ZD621 / ZD421 Thermal Transfer Models

All dimension are in millimeters

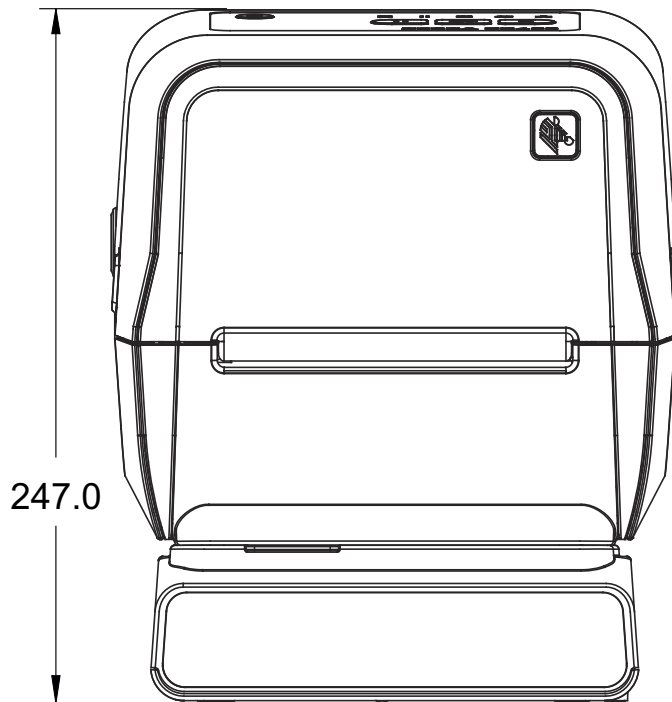

Printer with Attached Battery Base and Battery

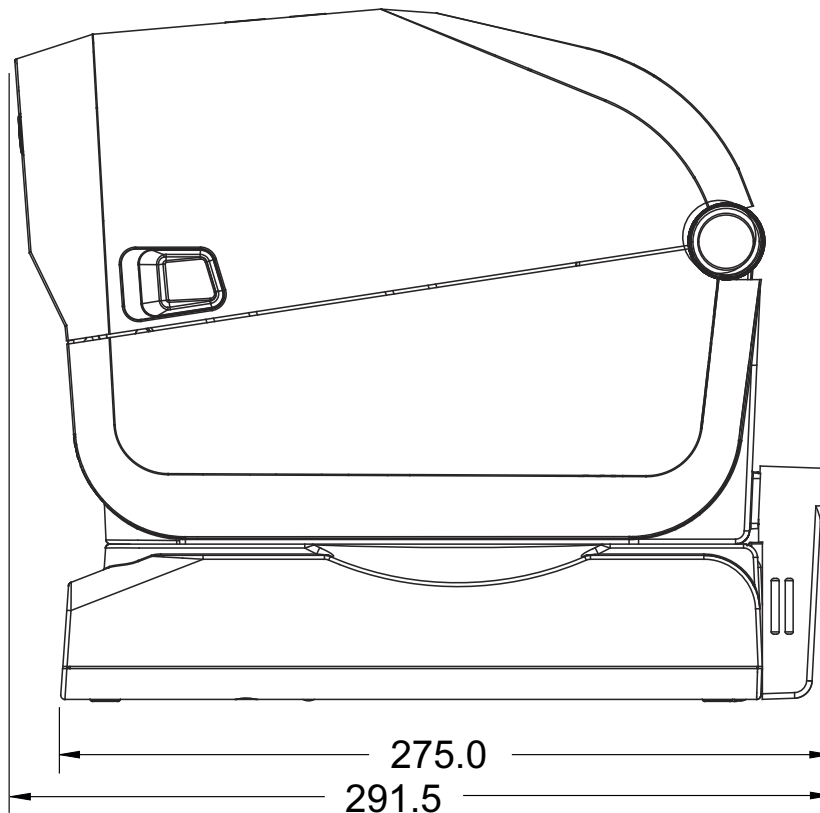

Dimensions

ZD621 / ZD421 Thermal Transfer Models

All dimension are in millimeters

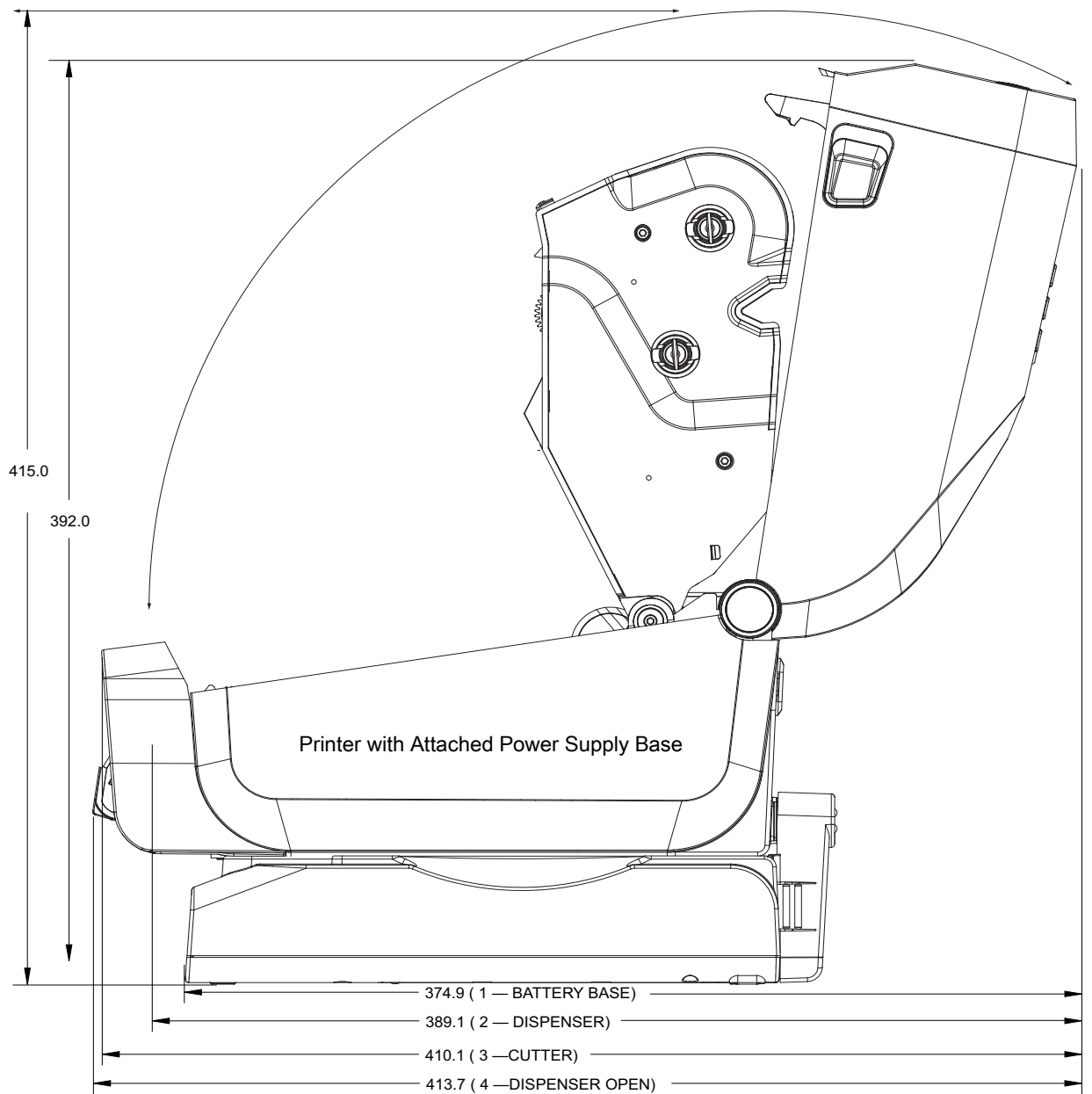

Loremipsum

Dimensions

ZD621 / ZD421 Thermal Transfer Models

Dimensions are in millimeters (mm)

Use M3 thread forming screws with maximum hole depth of 6 mm into the printer body.

Note - Do not remove the rubber feet or the printer can overheat.

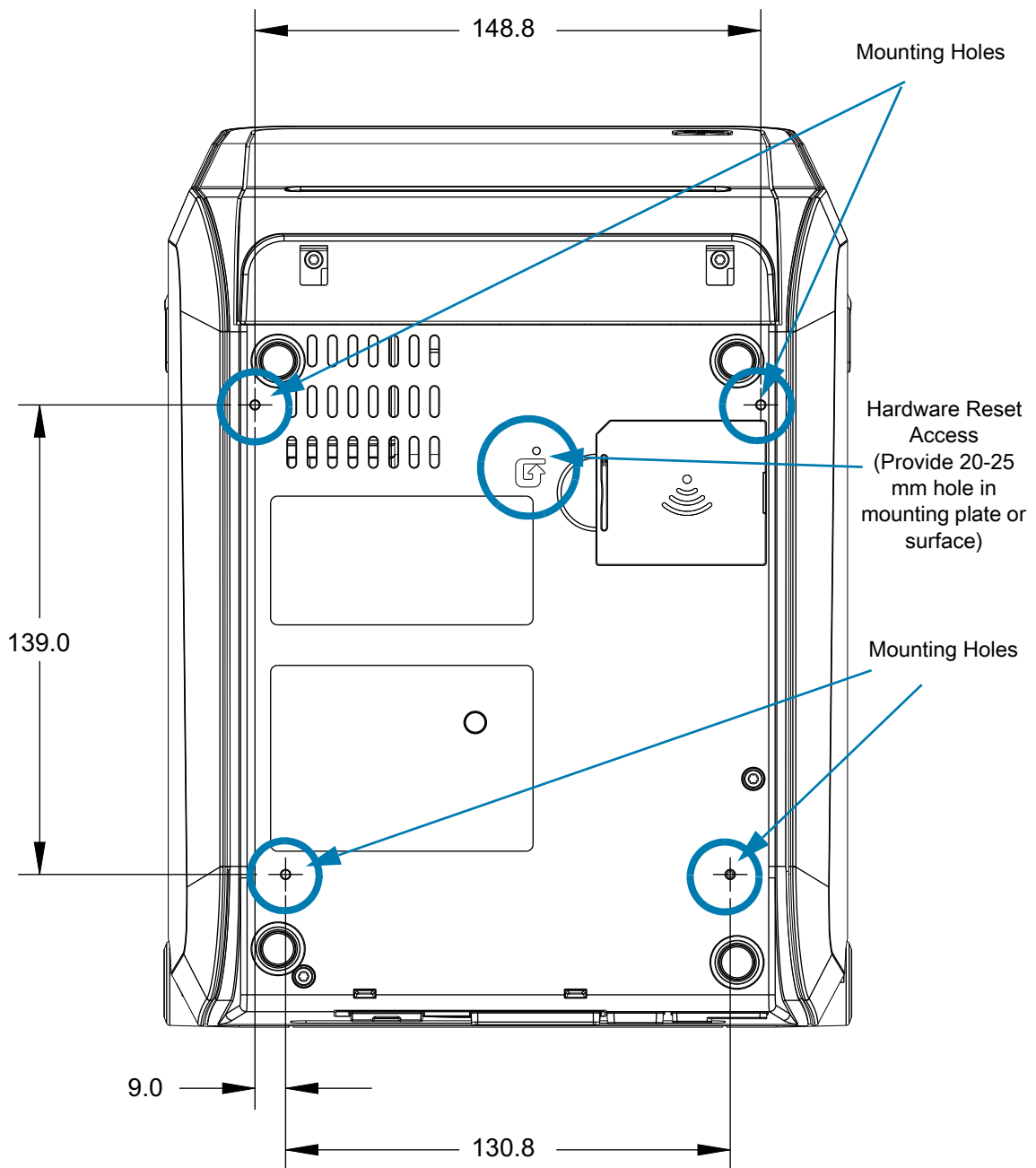

ZD421 Ribbon Cartridge Thermal Transfer Models

All dimension are in millimeters

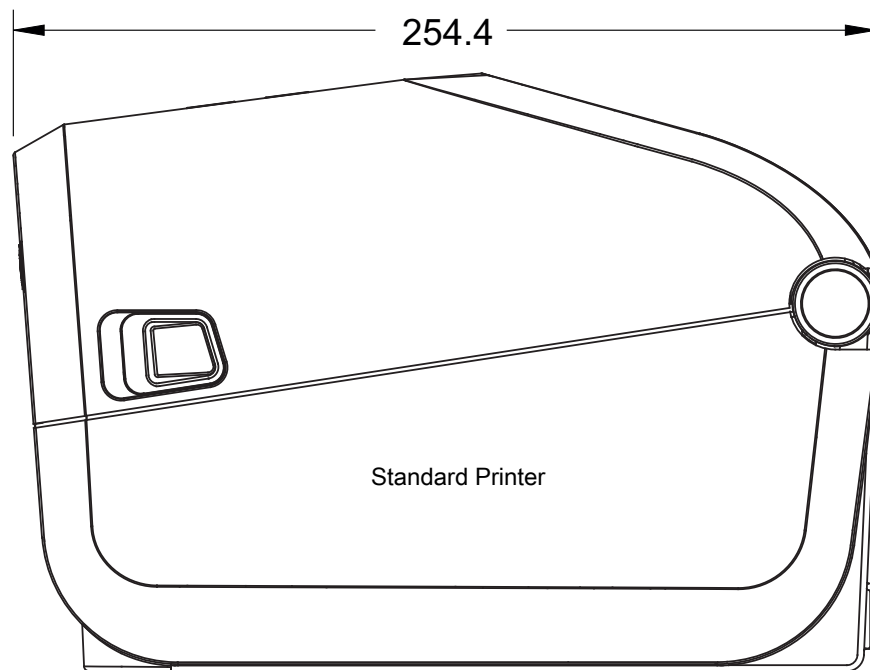
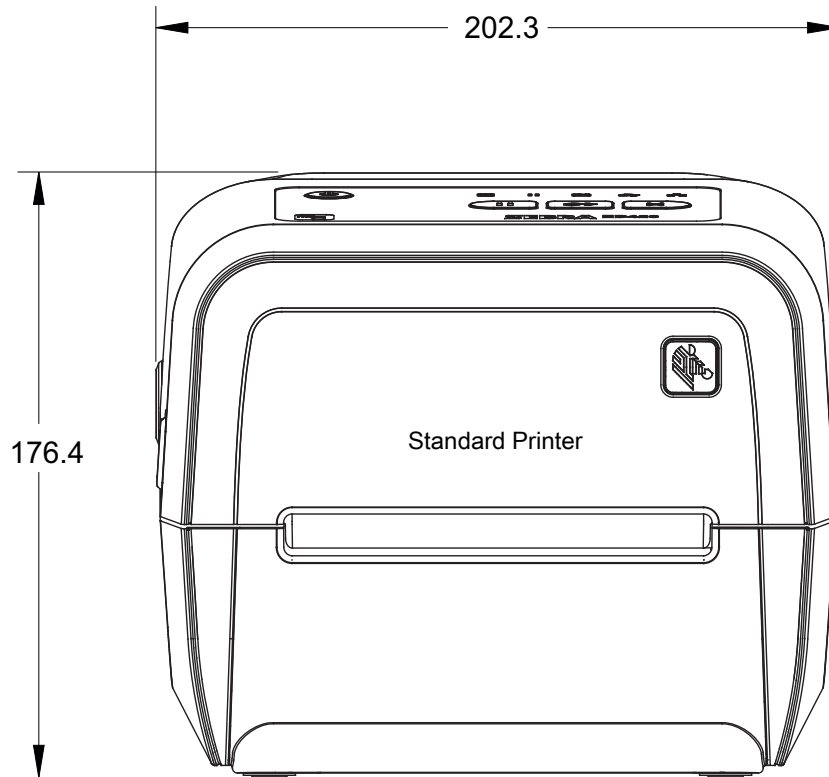

ZD421 Ribbon Cartridge Thermal Transfer Models

All dimension are in millimeters

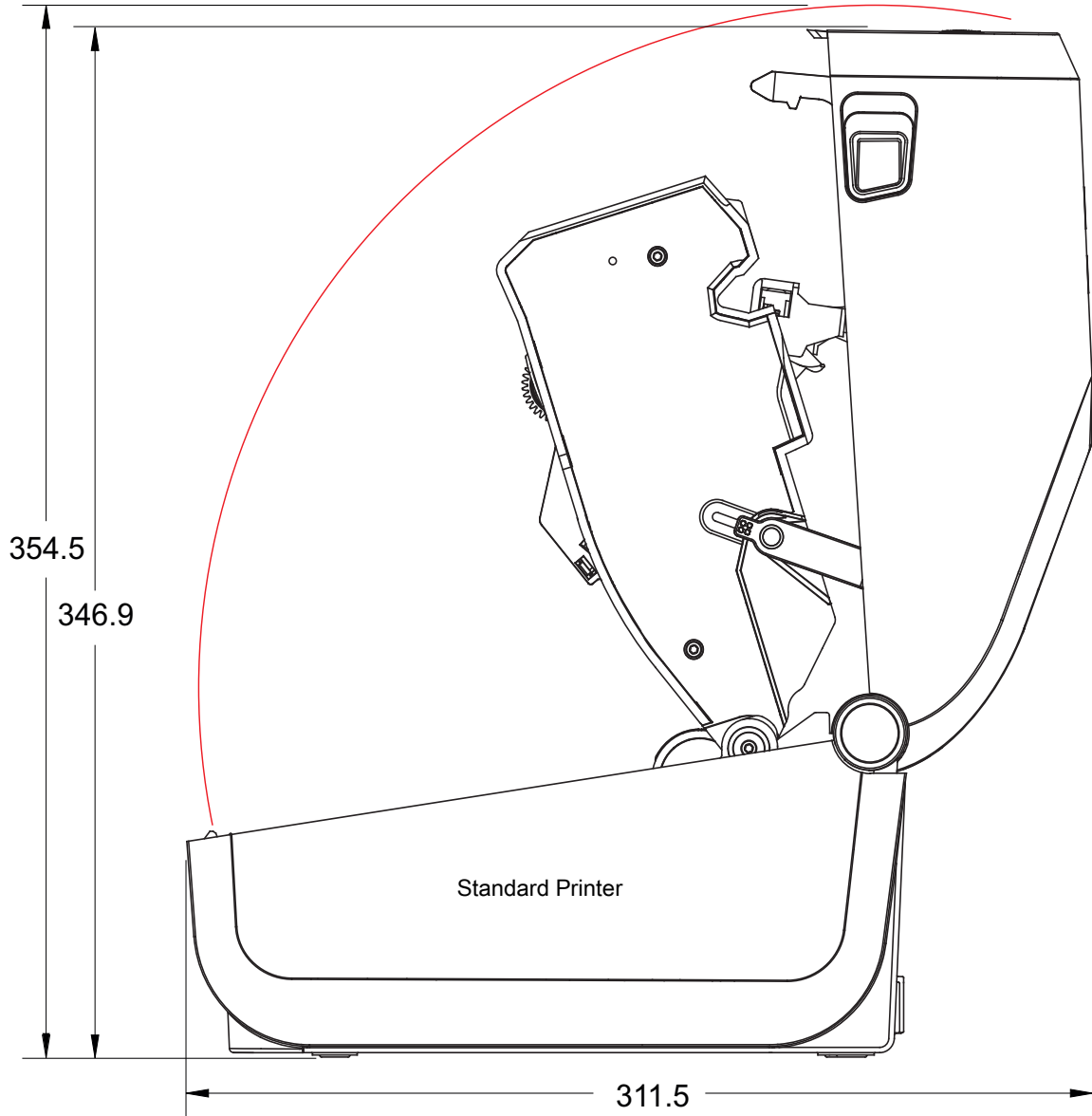

Dimensions

ZD421 Ribbon Cartridge Thermal Transfer Models

All dimension are in millimeters

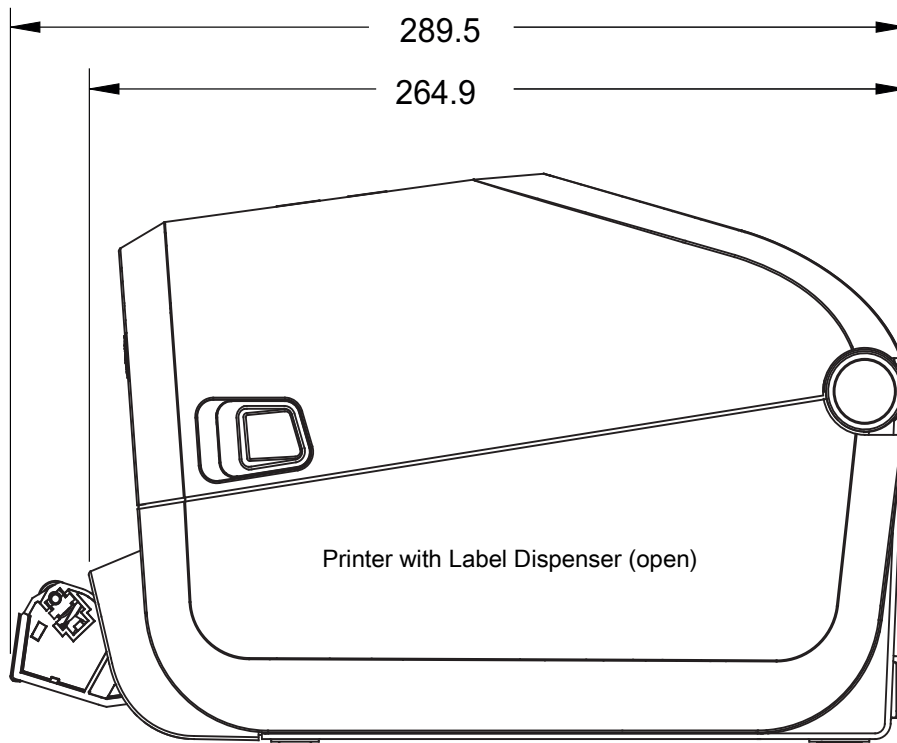
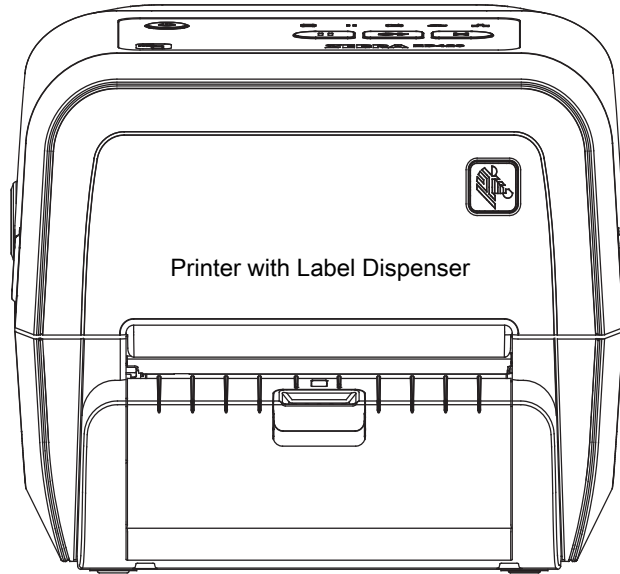

ZD421 Ribbon Cartridge Thermal Transfer Models

All dimension are in millimeters

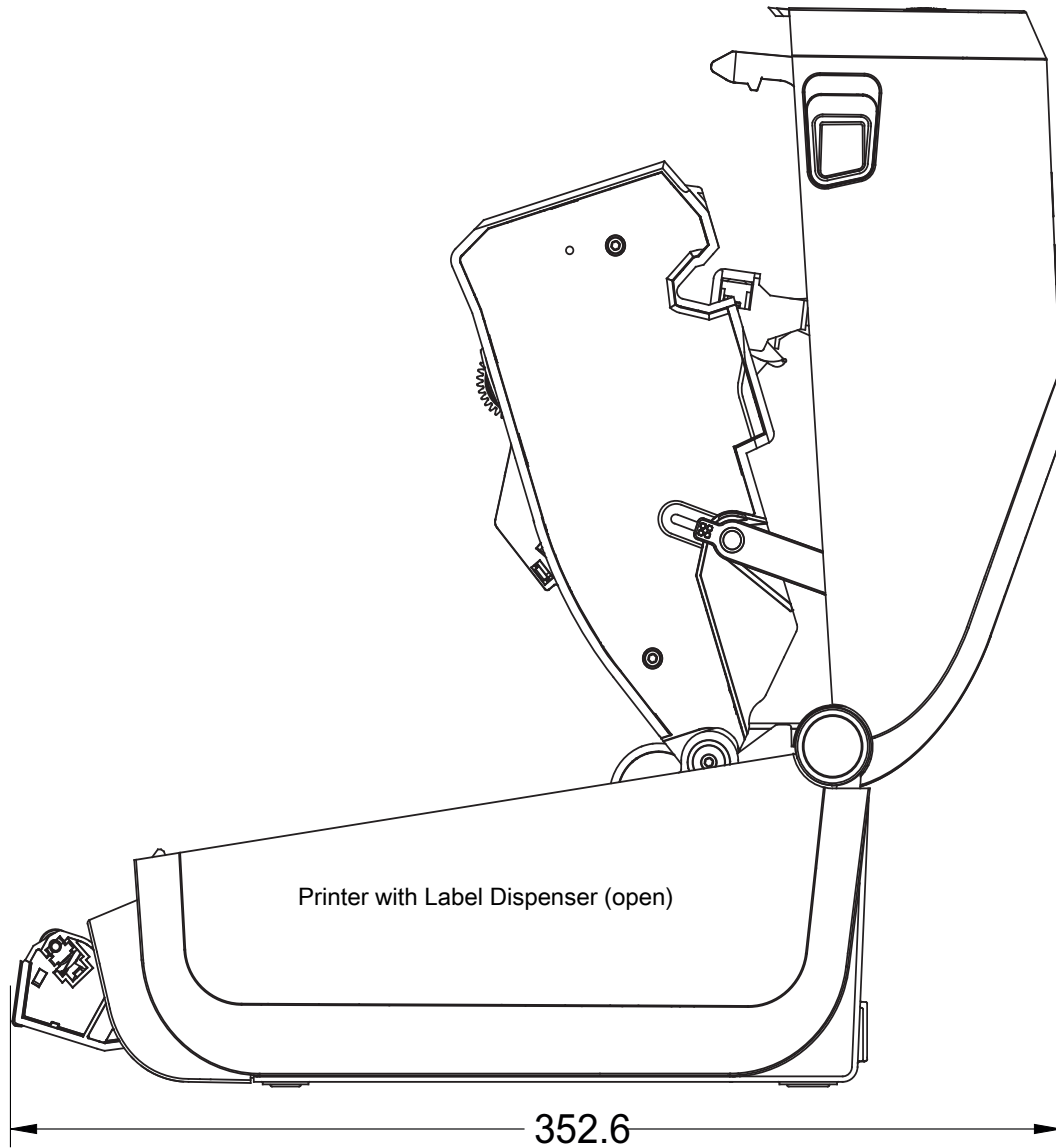

Dimensions

ZD421 Ribbon Cartridge Thermal Transfer Models

All dimension are in millimeters

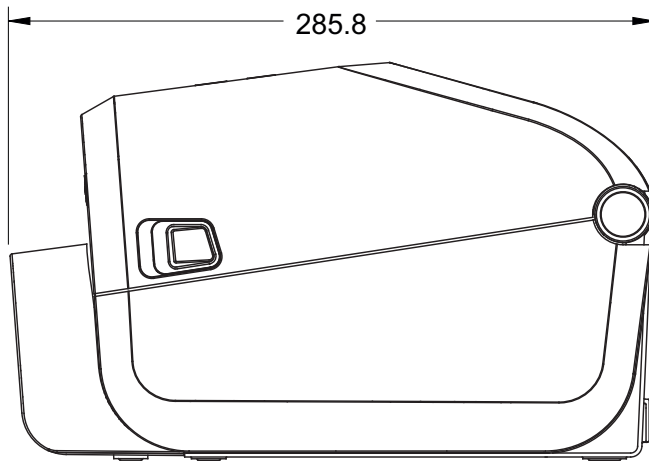

Printer with Cutter

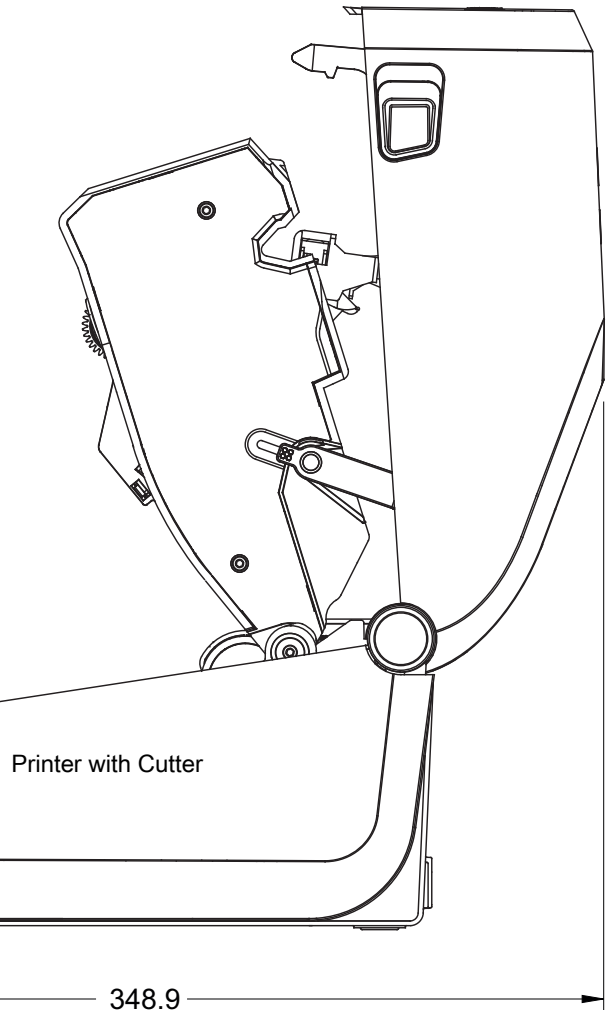
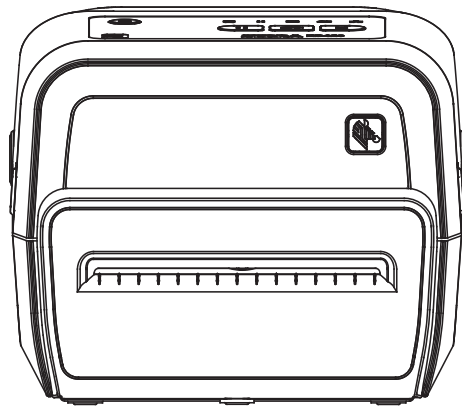

Printer with Cutter

Dimensions

ZD421 Ribbon Cartridge Thermal Transfer Model

All dimension are in millimeters

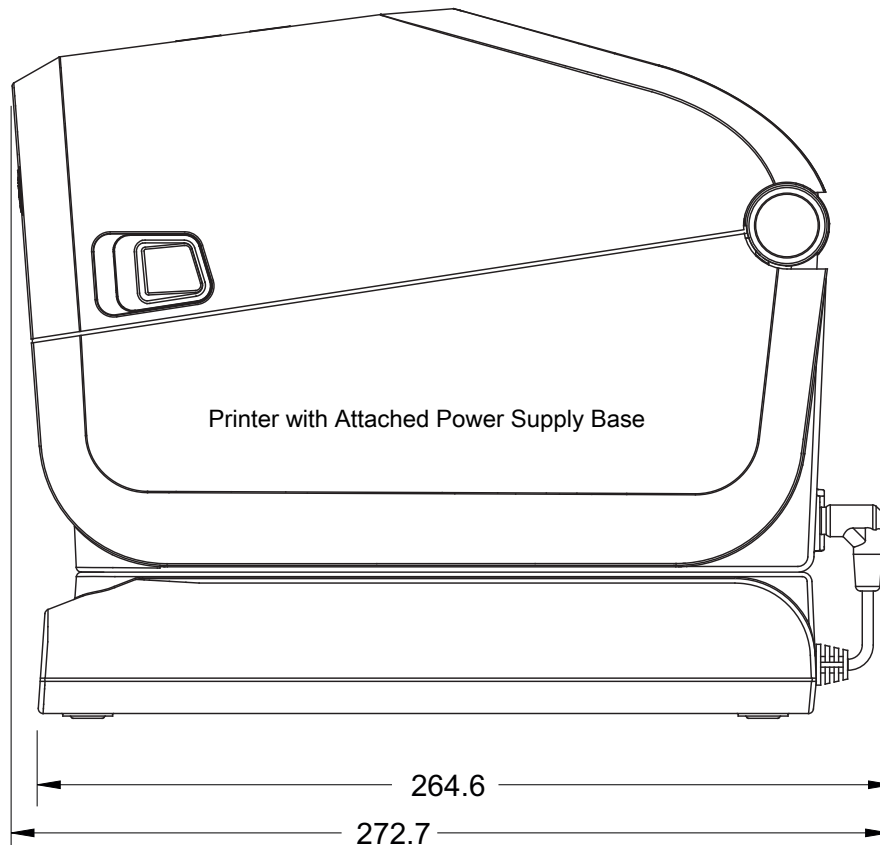
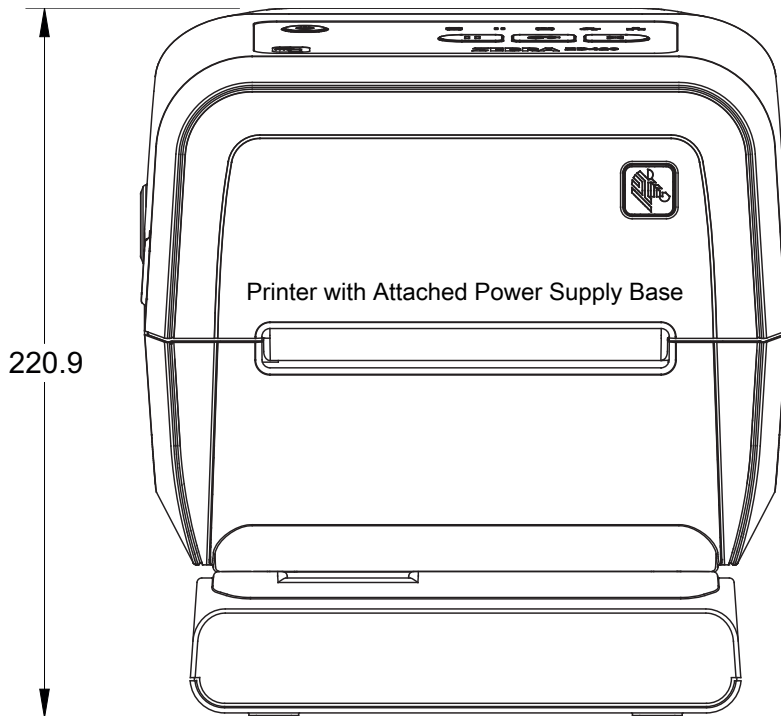

Dimensions

ZD421 Ribbon Cartridge Thermal Transfer Model

All dimension are in millimeters

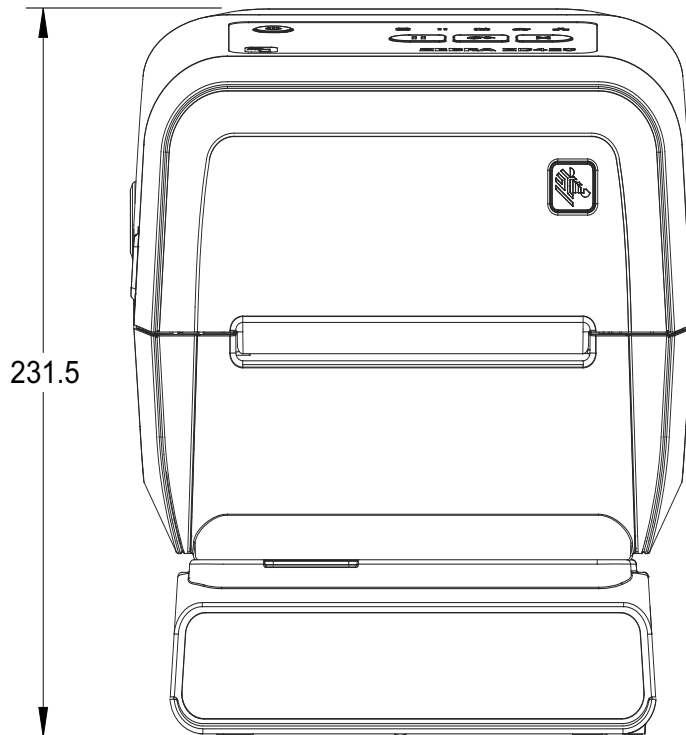

Printer with Attached Battery Base with Battery

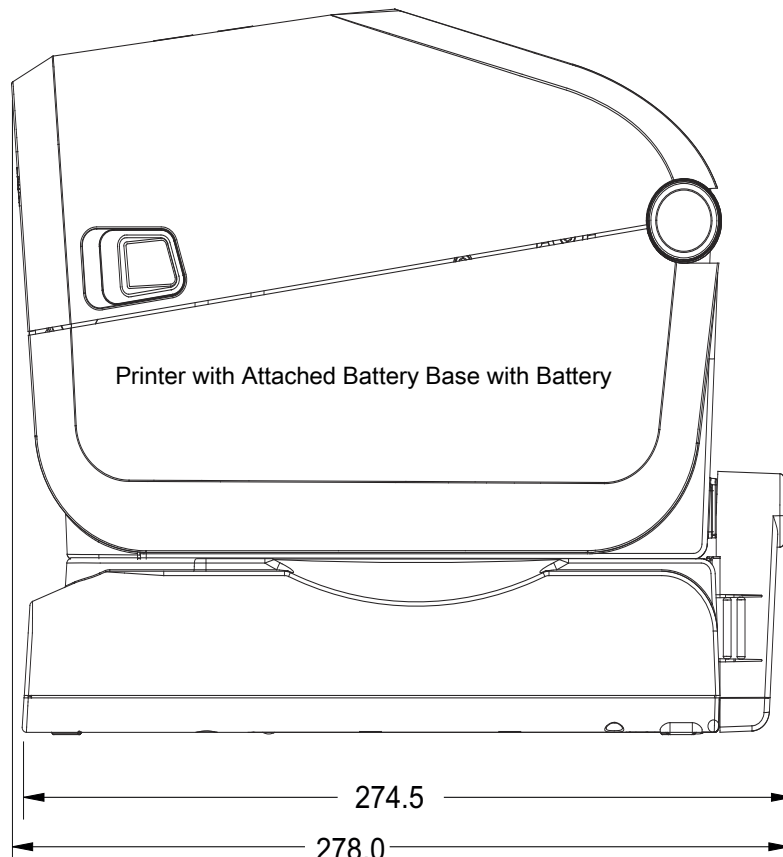

ZD421 Ribbon Cartridge Thermal Transfer Models

Dimensions are in millimeters (mm)

- 1 Hardware Reset Access — Provide 20-25 mm hole in mounting plate or surface.
- 2 Mounting Holes

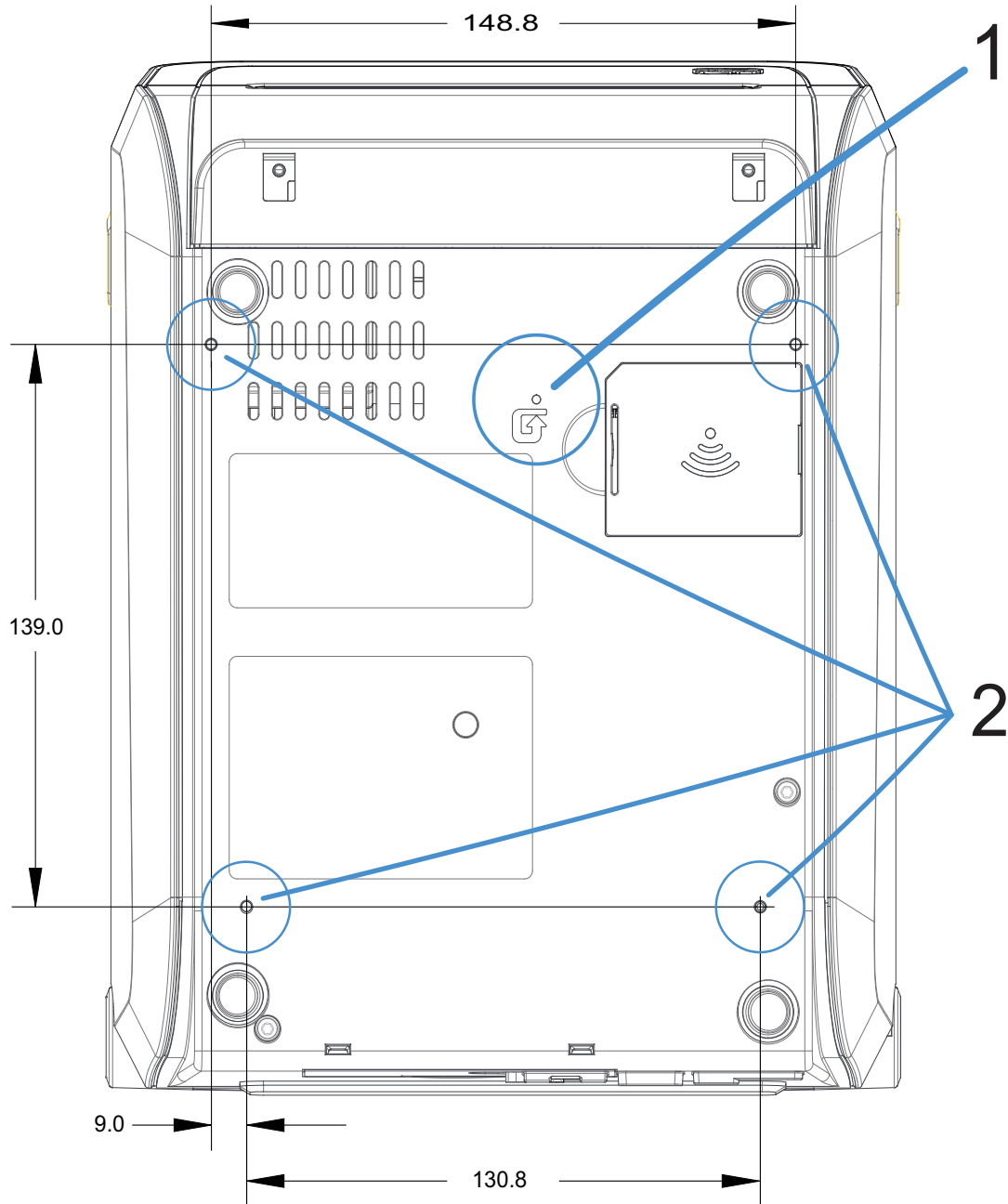

Use M3 thread forming screws with maximum hole depth of 6 mm into the printer body.

Note - Do not remove the rubber feet or the printer can overheat.

ZD621 / ZD421 Direct Thermal Models

All dimension are in millimeters

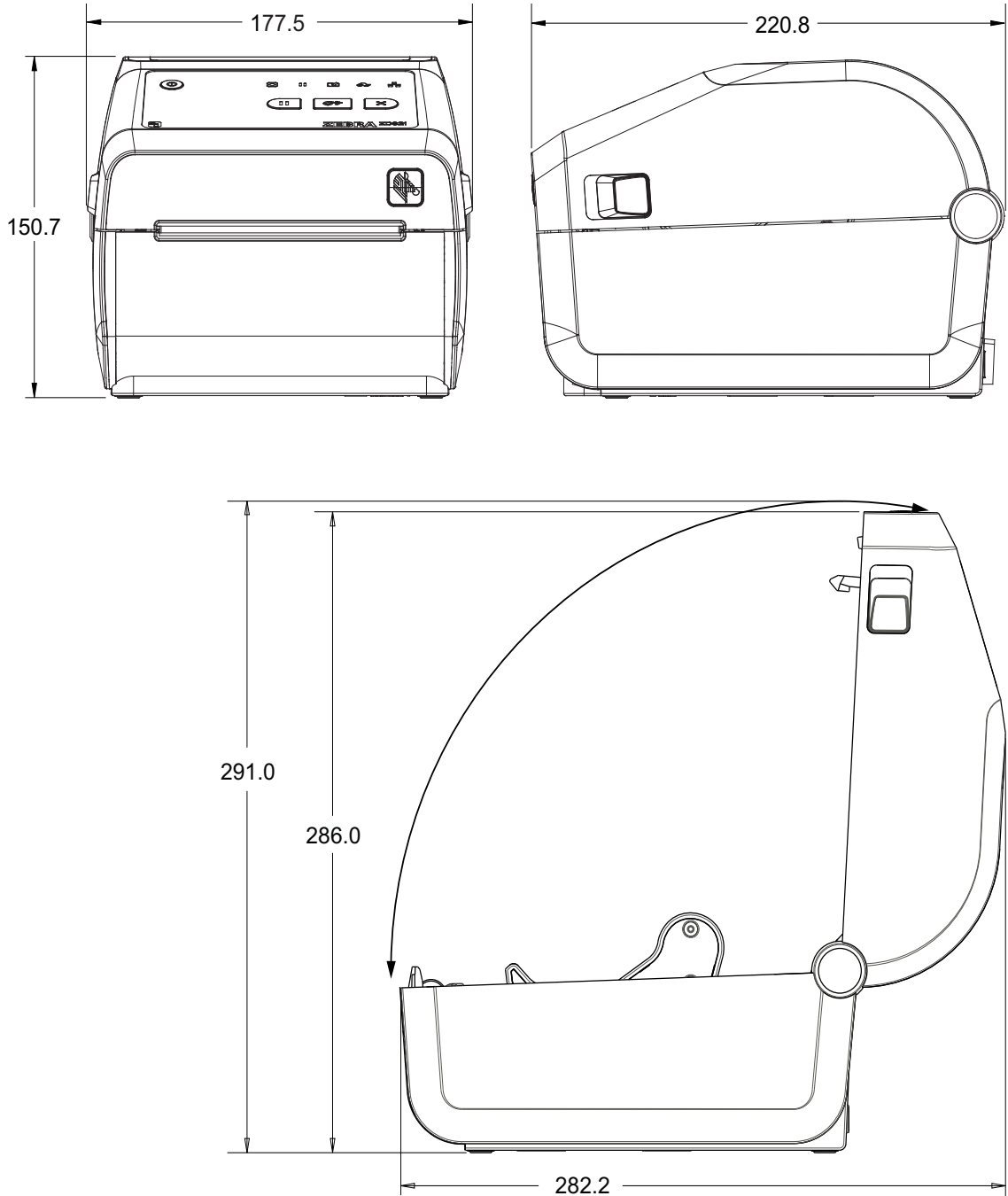

Dimensions

ZD621 / ZD421 Direct Thermal Models

All dimension are in millimeters

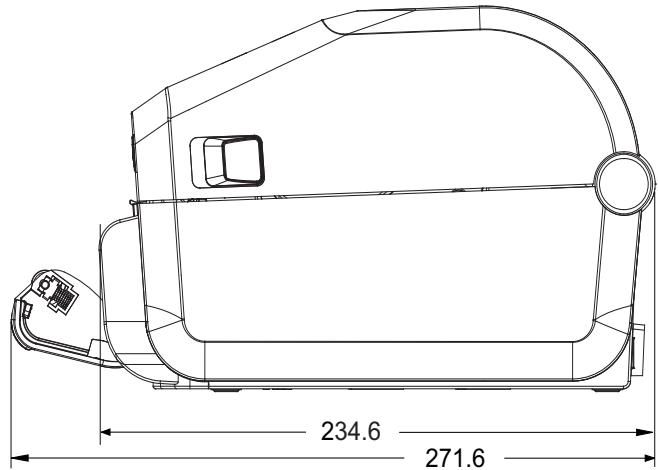
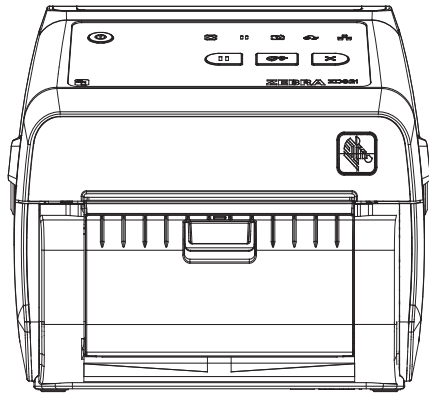

Printer with Label Dispenser

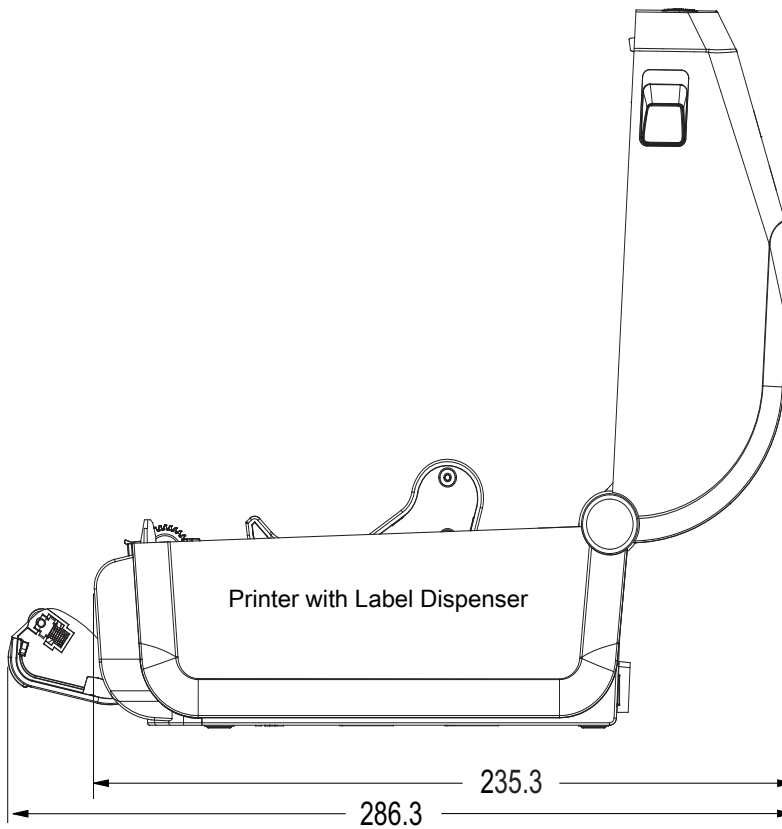

Dimensions

ZD621 / ZD421 Direct Thermal Models

All dimension are in millimeters

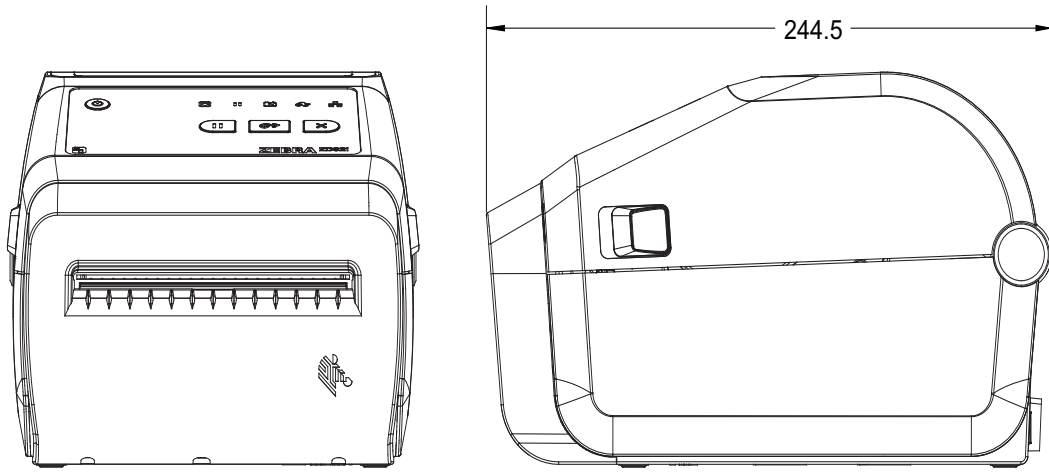

Printer with Cutter

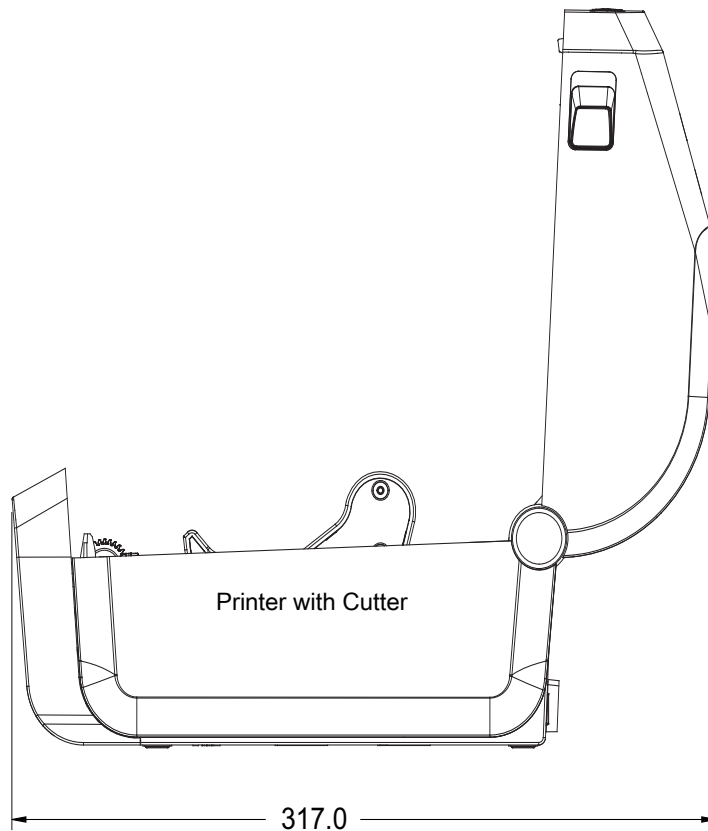

Dimensions

ZD621 / ZD421 Direct Thermal Models

All dimension are in millimeters

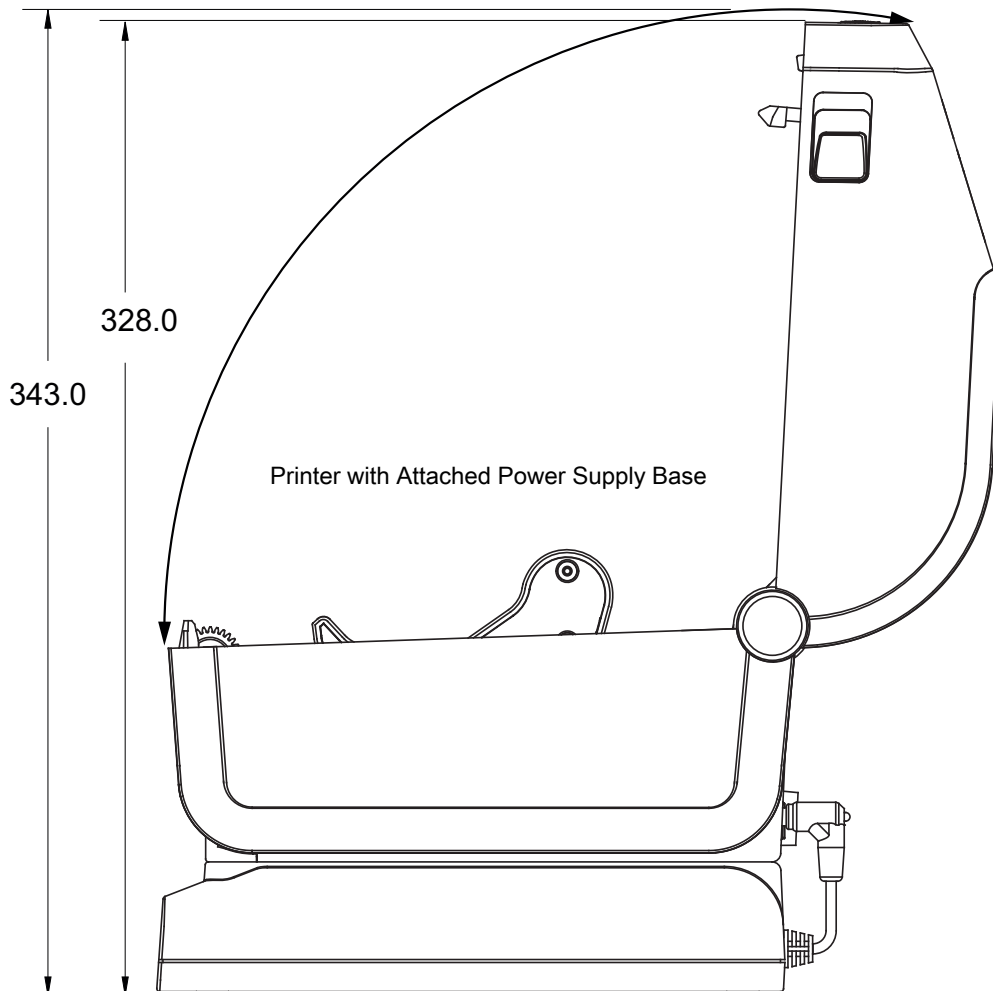
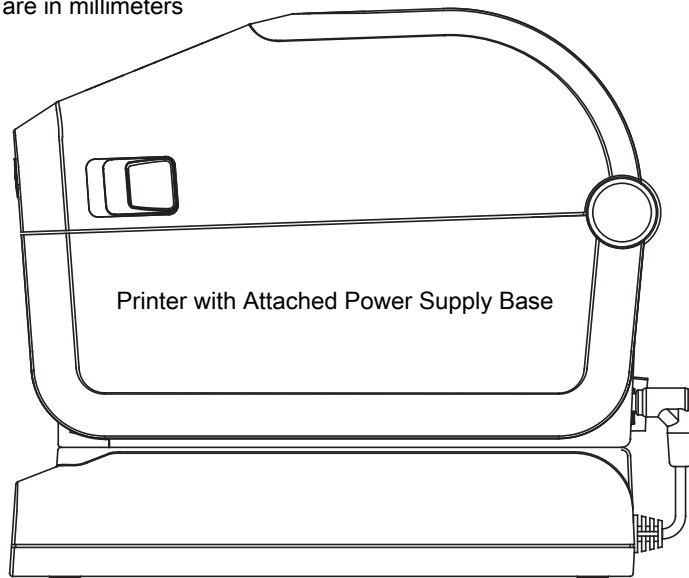

Dimensions

ZD621 / ZD421 Direct Thermal Models

All dimension are in millimeters

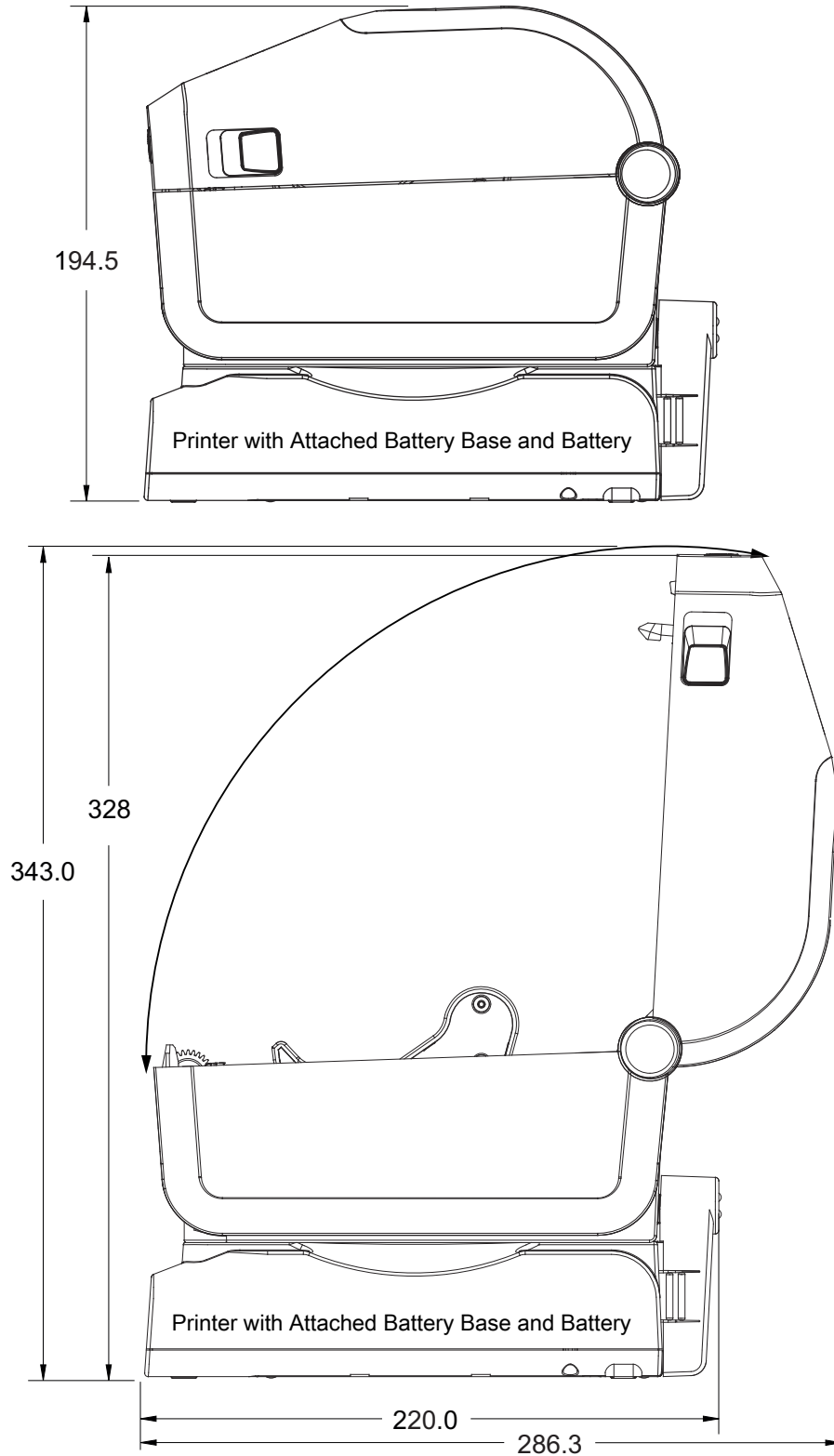

Dimensions

ZD621 / ZD421 Direct Thermal Models

All dimension are in millimeters

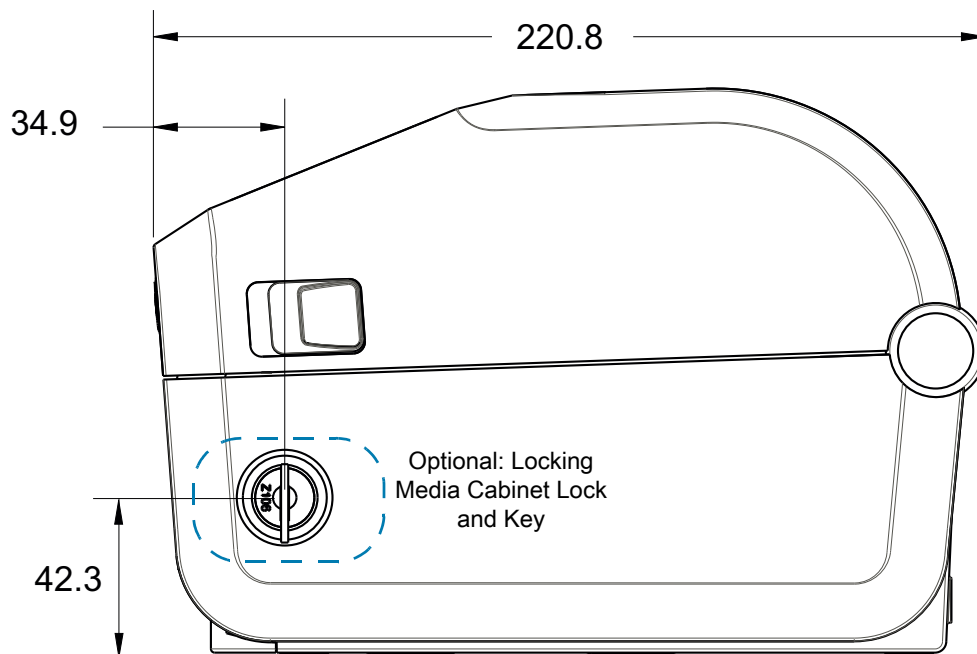
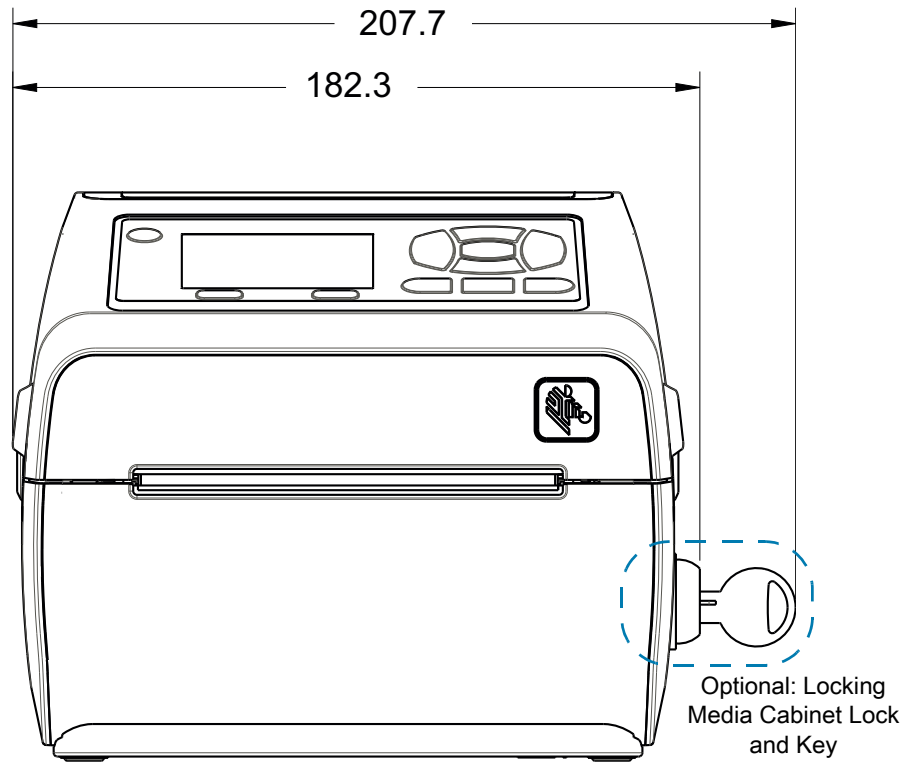

Dimensions

ZD621ZD621 / ZD421 Direct Thermal Models

Dimensions are in millimeters (mm)

- 1 Mounting Holes
- 2 Hardware Reset Access — Provide 20-25 mm hole in mounting plate or surface.

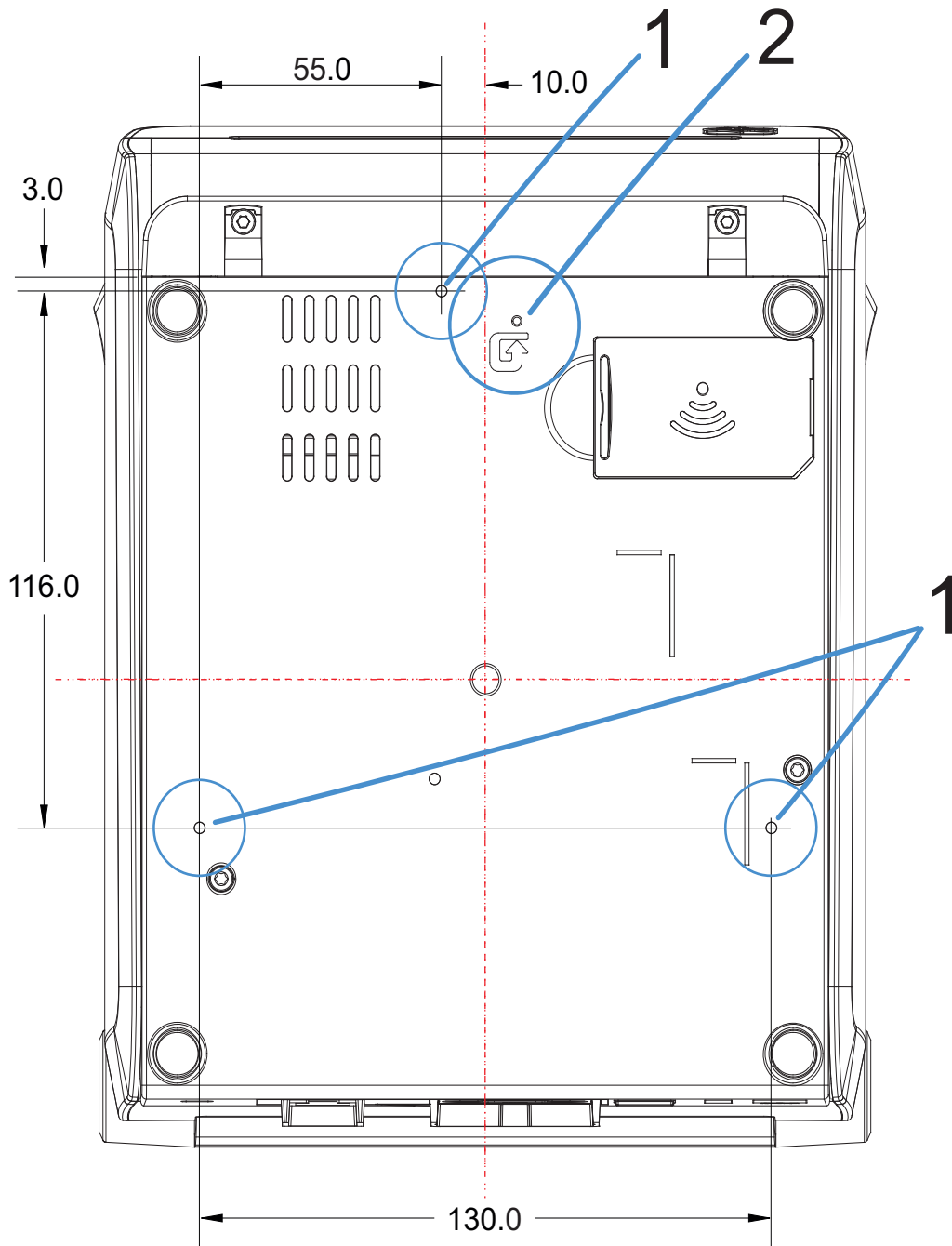

Use M3 thread forming screws with maximum hole depth of 6 mm into the printer body.



IMPORTANT: Do not remove the rubber feet or the printer can overheat.

Media

This section provides a simple media overview for your printer.

Types of Thermal Media



IMPORTANT: Zebra strongly recommends the use of Zebra-brand supplies in order to ensure consistent high-quality printing. A wide range of paper, polypropylene, polyester, and vinyl stock has been specifically engineered to enhance the printing capabilities of the printer and to prevent premature printhead wear.

To purchase supplies, go to zebra.com/howtobuy.

- Your printer can use various types of media:
- **Standard media**—Most standard (non-continuous) media uses an adhesive backing that sticks individual labels or a continuous length of labels to a liner.
- **Continuous roll media**—Most continuous roll media is direct thermal media (similar to FAX paper) and is used for receipt or ticket style printing.
- **Tag stock**—Tags are usually made from a heavy paper (up to 0.0075in./0.19mm thick). Tag stock does not have adhesive or a liner, and it is typically perforated between tags.

For more information on basic media types, go to [Table 2 on page 338](#).

The printer typically uses roll media, but you can use fan-fold or other continuous media too.

Determining Thermal Media Types

Thermal transfer media requires ribbon for printing while direct thermal media does not. To determine if ribbon must be used with a particular media, perform a media scratch test.

To perform a media scratch test, complete these steps:

1. Scratch the print surface of the media with a finger nail or pen cap. Press firmly and quickly while dragging it across the media surface. Direct thermal media is chemically treated to print (expose) when heat is applied. This test method uses friction heat to expose the media.
2. Did a black mark appear on the media?

Appears on the media

Direct thermal. No ribbon is required.

Does not appear on the media

Thermal transfer. A ribbon is required.
Not supported by this printer.

General Media and Print Specifications

- Direct Thermal — Max. Media width: 108mm (4.25 in.)
- Thermal Transfer ZD621, ZD621R, ZD421 Cartridge — Max. Media width: 112mm (4.09 in.)
- Thermal Transfer ZD421, ZD421CN — Max. Media width: 118mm (4.65 in.)
- All Printers — Min. Media width: 15mm (0.585 in.)
- Media length:
 - 990mm (39 in.) max.
 - 6.35mm (0.25 in.) min. – Tear Off or Label
 - 12.7mm(0.50 in.) min. – Peel
 - 12.7mm (0.50 in.) min. - Cutter
- Media thickness:
 - 0.06mm (0.0024 in.) min. – all requirements
 - 0.1905mm (0.0075 in.) max. – all requirements
- Media Roll Outer Diameter (O.D.) max.: 127mm (5.0 in.)
- Media Roll Core Inner Diameter (I.D.):
 - 12.7mm (0.5 in.) I.D. - Standard roll configuration
 - 25.4mm (1 in.) I.D. - Standard roll configuration
 - 38.1mm (1.5 in.) I.D. - with optional media roll adapter
 - 50.8mm (2.0 in.) I.D. - with optional media roll adapter
 - 76.2mm (3.0 in.) I.D. - with optional media roll adapter
- Ribbon Rolls - 74 meter
 - Ribbon Length - 74 m (243 feet)
 - Ribbon Width Max. - 110 mm (4.33 in.)
 - Ribbon Width Min. - 33 mm (1.3 in.) ‡
 - Ribbon Core I.D. - 12.7mm (0.5 in.)
 - Wax, Wax/Resin, and Resin transfer materials
- Ribbon Rolls - 300 meter
 - Ribbon Length - 300 m (984 feet)
 - Ribbon Width Max. - 110 mm (4.33 in.)
 - Ribbon Width Min. - 33 mm (1.3 in.) ‡
 - Wax, Wax/Resin, and Resin transfer materials



CAUTION—PRODUCT DAMAGE: Transfer ribbon should always cover the entire width of the media (and liner) to prevent damaging the printhead.

- ZD421 Ribbon Cartridges

- Ribbon Length - 74 m (243 feet)
- Ribbon Width Max. - 110 mm (4.33 in.)
- Ribbon Width Min. - 33 mm (1.3 in.) ‡
- Colors available in Black - Wax, Wax Resin, and Resin transfer materials
- Dot pitch:
 - 203 dpi: 0.125mm (0.0049 in.)
 - 300 dpi: 0.085mm (0.0033 in.)
- Barcode modulus x-dim:
 - 203 dpi: 0.005-0.050 in.
 - 300 dpi: 0.00327 - 0.03267 in.

Label Dispenser (Peeler)

The printer supports a field installed label dispense option with label taken sensor for batch processing of labels.

- Paper Thickness:
 - Min. 0.06 mm (0.0024 in.)
 - Max. 0.1905 mm (0.0075 in.)
- Media Width:
 - Min. 15 mm (0.585 in.)
 - Thermal Transfer ZD621, ZD621R, and ZD421 Cartridge Max. 118 mm (4.65 in.)
 - Thermal Transfer ZD421 and ZD421CN Max. 112 mm (4.09 in.)
 - Direct Thermal Printers Max. 108 mm (4.25 in.)
- Label Length:
 - All Printers Max. (theoretical): 990mm (39 in.)
 - Thermal Transfer Printers Max. (tested): 279.4mm (11 in.)
 - Direct Thermal Printers Max. (tested): 330mm (13 in.)
 - All Printers Min.: 12.7mm (0.5 in.)

Standard (Media) Cutter

The printer supports a field installed media cutter option for full width cutting of label liner, tag or receipt media.



- A medium duty cutter for cutting label liner and light tag media (LINER/TAG). Do not cut through labels, adhesive or embedded circuitry.
- Paper Thickness:
 - Min. 0.06 mm (0.0024 in.)
 - Max. 0.1905 mm (0.0075 in.)
- Cut Width:
 - Min. 15 mm (0.585 in.)
 - Thermal Transfer ZD621, ZD621R, and ZD421 Cartridge Max. 118 mm (4.65 in.)
 - Thermal Transfer ZD421 and ZD421CN Max. 118 mm (4.65 in.)
 - Direct Thermal Printers Max. 109 mm (4.29 in.)
- Minimum distance between cuts (label length): 25.4 mm (1 in.). Cutting shorter media lengths between the cuts may cause the cutter to jam or error.
- By design, the cutter is self cleaning and does not require preventive maintenance of the internal cutter mechanism.

Linerless (Media) Cutter - Direct Thermal only

The printer supports a field installed media cutter option for full width cutting of linerless media.

- A full width linerless media cutter (LINERLESS CUT).
- Paper Thickness:
 - Min. 0.06 mm (0.0024 in.)
 - Max. 0.1905 mm (0.0075 in.)
- Cut Width:
 - Min. 15 mm (0.585 in.)
 - Max. 109 mm (4.29 in.)
- Minimum distance between cuts (label length): 25.4 mm (1 in.). Cutting shorter media lengths between the cuts may cause the cutter to jam or error.
- By design, the cutter is self cleaning and does not require preventive maintenance of the internal cutter mechanism. Go to [Linerless Platen \(Drive\) Roller on page 241](#) cleaning and [Media Path Cleaning on page 246](#) to maintain optimal linerless media cut operation.

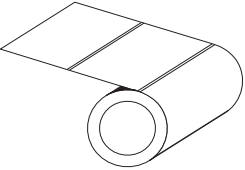
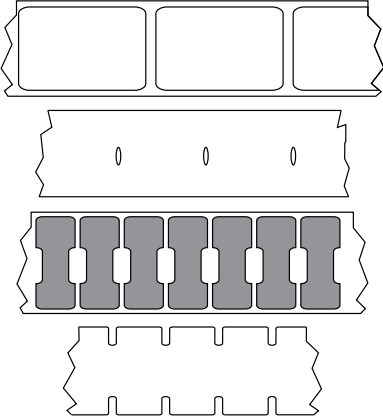
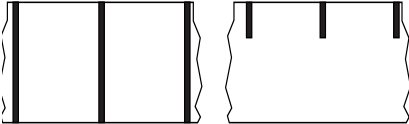
Table 2 Types of Media Roll and Fanfold Media

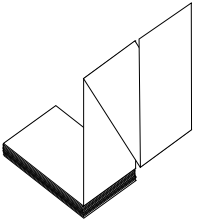
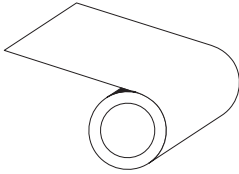
Media Type	How It Looks	Description
<p>Non-Continuous Roll Media</p>		<p>Labels have adhesive backing that sticks them to a liner. Tags (or tickets) are separated by perforations.</p> <p>Individual labels or tags are tracked and position controlled by one or more of the following methods:</p> <ol style="list-style-type: none"> Web media separates labels by gaps, holes, or notches. <div style="text-align: center;">  </div> Black mark media uses pre-printed black marks on the back side of the media to indicate label separations. <div style="text-align: center;">  </div> Perforated media has perforations that allow the labels or tags to be separated from each other easily in addition to position control marks, notches, or label gaps. <div style="text-align: center;">  </div>
<p>Non-Continuous Fanfold Media</p>		<p>Fan-Fold media is folded in a zigzag pattern. Fanfold media can have the same label separations as non-continuous roll media. The separations would fall on or near the folds.</p> <p>This type of media uses black marks or notches to track media format positioning.</p>
<p>Continuous Roll Media</p>		<p>Continuous roll media does not have gaps or typically holes, notches, or black marks either to indicate label separations. This allows the image to be printed anywhere on the label. A cutter can be used to cut apart individual labels. With continuous media, use the transmissive (gap) sensor so the printer can detect when the media runs out.</p>

ZPL Configuration

This section provides an overview of managing printer configuration, the Configuring Status Report, and Printer and Memory Printouts.

Managing the ZPL Printer Configuration

The ZPL printer is designed to allow you to change printer settings dynamically for fast first label out printing. Printer parameters that are persistent will be retained for future formats to use. Those settings will remain in effect until they are changed by subsequent commands, the printer is reset, power is cycled, or when you restore a parameter that has a factory default by resetting the printer to factory defaults. The ZPL Configuration Update command (^JU) saves and restores printer configurations to initialize (or re-initialize) the printer with pre-configured settings.

- To keep settings after a power cycle or printer reset, a ^JUS can be sent to the printer to save all current persistent settings.
- The values are recalled with a ^JUR command to restore the last saved values to the printer.

ZPL stores all parameters at once with a single command mentioned above. The legacy EPL programming language (supported by this printer) changes and saves individual commands immediately. Most printer settings are shared between ZPL and EPL. For example, changing the speed setting with EPL will also change the speed set for ZPL operations. The changed EPL setting will persist even after a power cycle or reset issued by either printer language.

A printer Configuration Report is available to assist the developer. The Configuration Report lists operating parameters, sensor settings, and printer status. It can be accessed by using the procedure in [Test Printing with the Configuration Report](#). The Zebra Setup Utility and the ZebraDesigner™ Windows driver also print this report and other printer reports to help you manage your printer.

ZPL Printer Configuration Format

Managing more than one printer can be done by creating a printer configuration programming file to send to one or more printers or ZebraNet™ Bridge can be used to clone a printer's setup. Figure 1 below shows the basic structure of a ZPL programming configuration file.

Refer to the ZPL programmer's guide and the [Configuration Setting to Command Cross-reference](#) to create a programming file. The Zebra Setup Utility (ZSU) can be used to send programming files to the printer. Windows Notepad (text editor) can be used to create programming files.

Figure 6 Configuration Parameter Format Structure

^XA — Start Format Command

Format Commands are order sensitive

- a) General Print and command settings
- b) Media handling and behaviors
- c) Media print size

^JUS command to save

^XZ — End Format Command

Configuration Setting to Command Cross-reference

The Printer Configuration Report, shown below, provides a listing of a majority of the configurations settings that can be set by ZPL command.

Figure 7 Configuration Report Printout

PRINTER CONFIGURATION	
Zebra Technologies ZTC ZD620-203dpi ZPL 50J164202531	
+15.0.....	DARKNESS
LOW.....	DARKNESS SWITCH
8.0 IPS.....	PRINT SPEED
+000.....	TEAR OFF ADJUST
TEAR OFF.....	PRINT MODE
CONTINUOUS.....	MEDIA TYPE
TRANSMISSIVE.....	SENSOR SELECT
DIRECT-THERMAL.....	PRINT METHOD
830.....	PRINT WIDTH
2030.....	LABEL LENGTH
39.0IN 988MM.....	MAXIMUM LENGTH
MAINT. OFF.....	EARLY WARNING
CONNECTED.....	USB COMM.
AUTO.....	SER COMM. MODE
9600.....	BAUD
8 BITS.....	DATA BITS
NONE.....	PARITY
XON/XOFF.....	HOST HANDSHAKE
NONE.....	PROTOCOL
NORMAL MODE.....	COMMUNICATIONS
<~> 7EH.....	CONTROL PREFIX
<^> SEH.....	FORMAT PREFIX
<,> 2CH.....	DELIMITER CHAR
ZPL II.....	ZPL MODE
INACTIVE.....	COMMAND OVERRIDE
NO MOTION.....	MEDIA POWER UP
FEED.....	HEAD CLOSE
DEFAULT.....	BACKFEED
+000.....	LABEL TOP
+0000.....	LEFT POSITION
DISABLED.....	REPRINT MODE
045.....	WEB SENSOR
096.....	MEDIA SENSOR
128.....	TAKE LABEL
062.....	MARK SENSOR
004.....	MARK MED SENSOR
046.....	TRANS GAIN
034.....	TRANS LED
049.....	MARK GAIN
100.....	MARK LED
DPCSWFXM.....	MODES ENABLED
.....	MODES DISABLED
832 8/MM FULL.....	RESOLUTION
4.0.....	LINK-OS VERSION
V84.20.07ZP37536 <-	FIRMWARE
1.3.....	XML SCHEMA
6.5.0 0.770.....	HARDWARE ID
8192k.....	R: RAM
65536k.....	E: ONBOARD FLASH
NONE.....	FORMAT CONVERT
FW VERSION.....	IDLE DISPLAY
06/08/17.....	RTC DATE
07:07.....	RTC TIME
DISABLED.....	ZBI
2.1.....	ZBI VERSION
READY.....	ZBI STATUS
178 LABELS.....	NONRESET CNTR
178 LABELS.....	RESET CNTR1
178 LABELS.....	RESET CNTR2
1,290 IN.....	NONRESET CNTR
1,290 IN.....	RESET CNTR1
1,290 IN.....	RESET CNTR2
3,277 CM.....	NONRESET CNTR
3,277 CM.....	RESET CNTR1
3,277 CM.....	RESET CNTR2
002 WIRED,SERIAL...	SLOT 1
0.....	MASS STORAGE COUNT
0.....	HID COUNT
OFF.....	USB HOST LOCK OUT
FIRMWARE IN THIS PRINTER IS COPYRIGHTED	

Sensor Settings used
for
Service Purposes

Table 3 ZPL Commands and Configuration Report Callout Cross-Reference

Command	Listing Name	Description
~SD	DARKNESS	Default: 10.0
-	DARKNESS SWITCH	LOW (Default), MEDIUM, or HIGH
^PR	PRINT SPEED	Default: 152.4 mm/s / 6 IPS (max.) - 203 dpi 101.6 mm/s / 4 IPS (max.) - 300 dpi
~TA	TEAR OFF	Default: +000
^MN	MEDIA TYPE	Default: GAP/NOTCH
	SENSOR SELECT	Default: AUTO (^MNA - Auto-Detect)
^MT	PRINT METHOD	THERMAL-TRANS or DIRECT-THERMAL
^PW	PRINT WIDTH	Default: 448 (dots for 203 dpi) or 640(dots for 300 dpi)
^LL	LABEL LENGTH	Default: 1225 (dots) (dynamically updated while printing)
^ML	MAXIMUM LENGTH	Default: 39.0IN 989MM
-	USB COMM.	Connection Status: Connected / Not Connected
^SCa	BAUD	Default: 9600
^SC,b	DATA BITS	Default: 8 BITS
^SC,,c	PARITY	Default: NONE
^SC,,,,e	HOST HANDSHAKE	Default: AUTO
^SC,,,,,f	PROTOCOL	Default: NONE
- SGD -**	COMMUNICATIONS	Default: NORMAL MODE
	SER COMM. MODE	Default: AUTO
^CT / ~CT	CONTROL CHAR	Default: <~> 7EH
^CC / ~CC	COMMAND CHAR	Default: <^> 5EH
^CD / ~CD	DELIM./CHAR	Default: <, > 2CH
^SZ	ZPL MODE	Default: ZPL II
- SGD -**	COMMAND OVERRIDE	Default: INACTIVE
^MFa	MEDIA POWER UP	Default: NO MOTION
^MF,b	HEAD CLOSE	Default: FEED
~JS	BACKFEED	Default: DEFAULT
^LT	LABEL TOP	Default: +000
^LS	LEFT POSITION	Default: +0000
~JD / ~JE	HEXDUMP	Default: NO (~JE)
	REPRINT MODE	Default: DISABLED

From this point in the Configuration Receipt listing, the printout has sensor settings and values displayed to troubleshoot sensor and media operations. These are typically used by Zebra Tech Support to diagnose printer problems.

** - Not supported with a ZPL command, uses the Set Get Do command in the ZPL manual. Refer to **device.command_override.xxxxx** in the ZPL Programmer's manual.

ZPL Configuration

The configuration settings listed here resume after the **TAKE LABEL** sensor value. These listings contain printer features seldom changed from default or provide status information.

Table 4 ZPL Commands and Configuration Receipt Callout Cross-Reference

Command	Listing Name	Description
^MP	MODES ENABLED	Default: CWF (refer to ^MP Command)
	MODES DISABLED	Default: (nothing set)
^JM	RESOLUTION	Default: 448 8/mm (203 dpi); 640 8/mm (300 dpi)
—	FIRMWARE	Lists ZPL Firmware Version
—	XML SCHEMA	1.3
—	HARDWARE ID	Lists Firmware Boot-block Version
	LINK-OS VERSION	
—	CONFIGURATION	CUSTOMIZED (after first use)
—	RAM	2104k..... R:
—	ONBOARD FLASH	6144k.....E:
^MU	FORMAT CONVERT	NONE
	RTC DATE	Date Displayed
	RTC TIME	Time Displayed
^JI / ~JI	ZBI	DISABLED (Requires key to enable)
	ZBI VERSION	2.1 (Displayed if installed)
	ZBI STATUS	READY
^JH ^MA ~RO	LAST CLEANED	X,XXX IN
	HEAD USAGE	X,XXX IN
	TOTAL USAGE	X,XXX IN
	RESET CNTR1	X,XXX IN
	RESET CNTR2	X,XXX IN
	NONRESET CNTR0 (1, 2)	X,XXX IN
	RESET CNTR1	X,XXX IN
	RESET CNTR2	X,XXX IN
	SLOT1	EMPTY / SERIAL / WIRED
	MASS STORAGE COUNT	0
	HID COUNT	0
	USB HOST LOCK OUT	OFF /ON
—	SERIAL NUMBER	XXXXXXXXXXXX
^JH	EARLY WARNING	MAINT. OFF

The printer has the ability to set a command or a group of commands once for all receipts (or labels) that follow. Those settings will remain in effect until they are changed by subsequent commands, the printer is reset, or you restore factory defaults.

Printer Memory Management and Related Status Reports

To help you manage printer resources, the printer supports a variety of format commands to manage memory, transfer objects (between memory areas, import and export), object naming, and provide various printer operating status reports. They are very similar to the old DOS commands like DIR (directory listing) and DEL (delete file). The most common reports are also part of the Zebra Setup Utility and ZebraDesigner™ Windows driver.

It is recommended that a single command be processed within this type of format (form). A single command is easily reused as a maintenance and development tool.

^XA — Start Format Command

A Single Format Command is recommended for purposes of reuse

^XZ — End Format Command

Many of the commands that transfer objects, manage and report on memory are control (~) commands. They do not need to be within a format (form). They will be processed immediately upon receipt by the printer whether in a format (form) or not.

ZPL Programming for Memory Management

ZPL has various printer memory locations that are used to run the printer, assemble the print image, store formats (forms), graphics, fonts and configuration settings.

- ZPL treats Formats (Forms), Fonts, and Graphics like files; and memory locations like disk drives in the DOS operating system environment:
 - Memory Object Naming: Up to sixteen (16) alphanumeric characters followed by a three (3) alphanumeric character file extension, for example: **123456789ABCDEF.TTF**
Legacy ZPL printers with V60.13 firmware and earlier can only use the 8.3 file name format versus today's 16.3 file name format.
- Allows moving objects between memory locations and deleting objects.
- Supports DOS directory style file list reports as printouts or status to the host.
- Allows use of 'wild cards' (*) in file access

Table 5 Object Management and Status Report Commands

Command	Name	Description
^WD	Print Directory Label	Prints a list of objects and resident barcodes and fonts in all addressable memory locations
~WC	Print Configuration Label	Prints a configuration Status Receipt (Label) Same as FEED Button mode one flash routine
^ID	Object Delete	Deletes objects from printer memory
^TO	Transfer Object	Used to copy an object or group of objects from one memory area to another.
^CM	Change Memory Letter Designation	Reassigns a letter designation to a printer memory area.
^JB	Initialize Flash memory	Similar to formatting a disk - erases all objects from the specified memory locations B: or E:.
~JB	Reset Optional Memory	Similar to formatting a disk - erases all objects from the B: memory (factory option).
~DY	Download Objects	Downloads and installs wide variety of printer usable programming objects: fonts (OpenType and TrueType), graphics, and other object data types. Recommendation: Use ZebraNet™ Bridge for downloading graphics and fonts in the printer.
~DG	Download Graphic	Downloads an ASCII Hex representation of a graphic image. This is used by ZebraDesigner™ (label creation application) for graphics.
^FL	Font Linking	Appends secondary TrueType font or fonts to the primary TrueType font to add glyphs (characters).
^LF	List Font Links	Prints a list of the linked fonts
^CW	Font Identifier	Assigns a single alphanumeric character as an alias to a font stored in memory.



IMPORTANT: Some factory installed ZPL fonts in your printer cannot be copied, cloned or restored to your printer by reloading or updating firmware. If these license restricted ZPL fonts are removed by an explicit ZPL object delete command, they must be repurchased and reinstalled via a font activation and installation utility. EPL fonts do not have this restriction.

