

ULINE H-965, H-1066
RUBBERMAID®
FLAT HANDLE CARTS

1-800-295-5510
uline.com

Para Español, vea páginas 3-4.
Pour le français, consulter les pages 5-6.

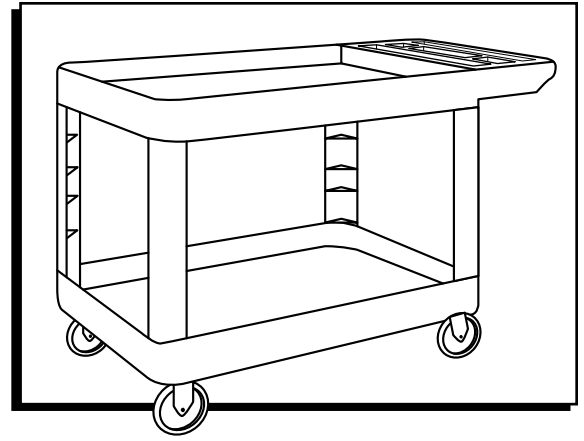

TOOLS NEEDED

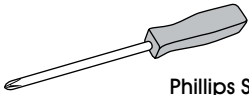

Phillips Screwdriver



Rubber Mallet

PARTS



Swivel Caster x 2

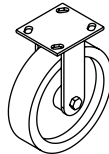

Rigid Caster x 2

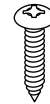

Screw x 24

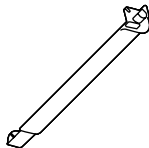

Support x 4

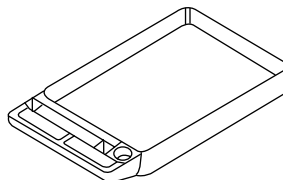

Top Shelf x 1

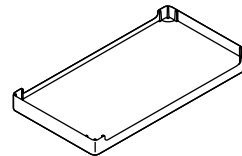

Bottom Shelf x 1

ASSEMBLY

Figure 1

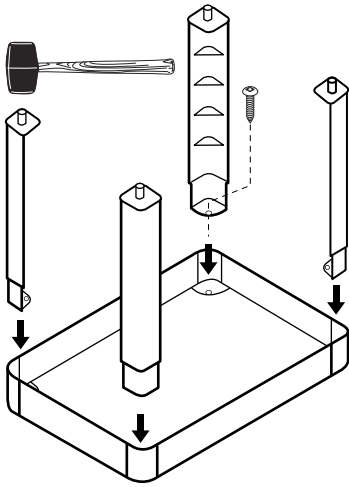

1. Tap supports into the top of the bottom shelf using the rubber mallet. Screw supports into place using four screws. (See Figure 1)

Figure 2

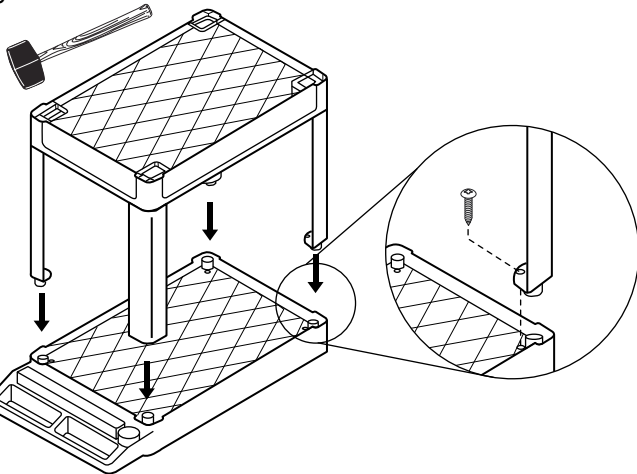

2. Flip bottom shelf over and tap bottom shelf and supports into underside of top shelf using rubber mallet. Screw supports into place using four screws. (See Figure 2)

Figure 3

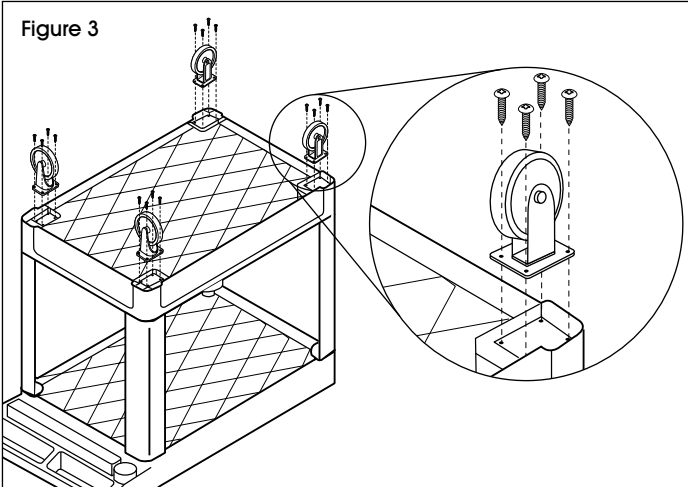

3. Screw the casters into the underside of the bottom shelf using 16 screws. Attach rigid casters at the front of the cart and swivel casters at the rear. (See Figure 3)

ULINE

1-800-295-5510

uline.com

ULINE H-965, H-1066

RUBBERMAID®
CARRITOS CON
ASA PLANA

800-295-5510
uline.mx

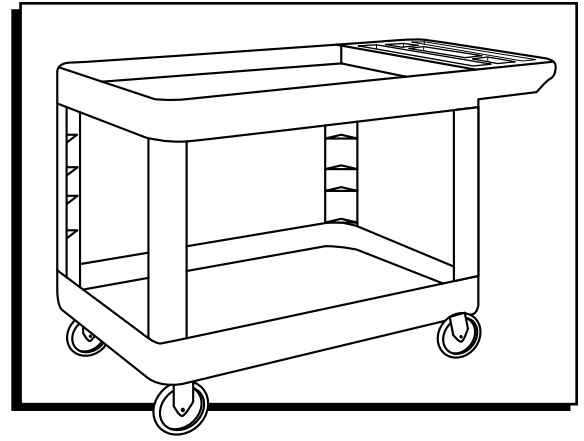

HERRAMIENTAS NECESARIAS

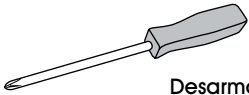

Desarmador Phillips



Mazo de Hule

PARTES



2 Ruedas Giratorias



2 Ruedas Fijas

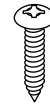

24 Tornillos

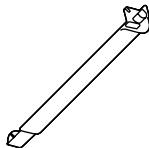

4 Soportes

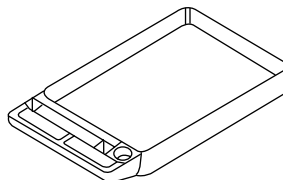

1 Repisa Superior

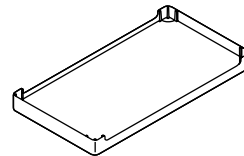

1 Repisa Inferior

ENSAMBLE

Diagrama 1

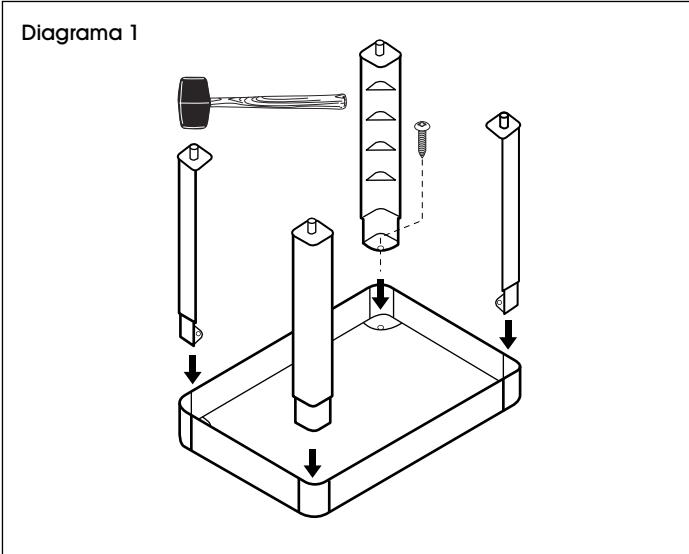

1. Golpee ligeramente los soportes para colocarlos en la parte superior de la repisa inferior usando un mazo de hule. Atornille los soportes en su lugar usando cuatro tornillos. (Vea Diagrama 1)

Diagrama 2

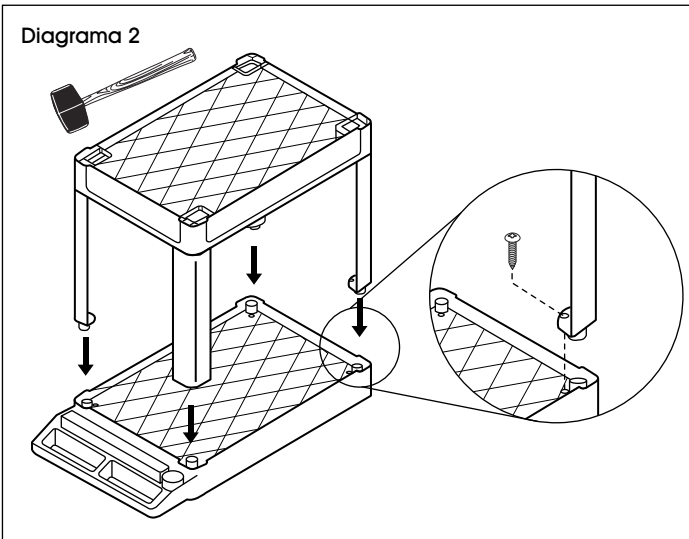

2. Voltee la repisa y golpee ligeramente la repisa inferior y soportes a la repisa superior usando un mazo de hule. Atornille los soportes en su lugar usando cuatro tornillos. (Vea Diagrama 2)

Diagrama 3

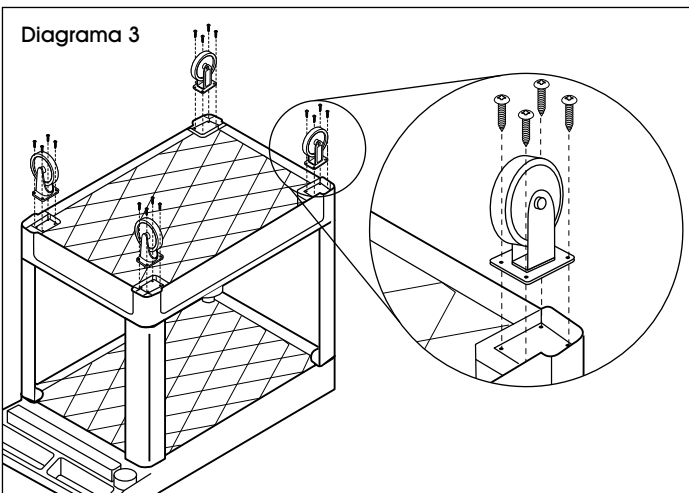

3. Atornille las ruedas a la parte de abajo de la repisa inferior usando 16 tornillos. Coloque las ruedas fijas en la parte delantera del carrito y ruedas giratorias en la parte trasera. (Vea Diagrama 3)

ULINE

800-295-5510
uline.mx

ULINE H-965, H-1066

**RUBBERMAID^{MD} -
CHARIOT À
POIGNÉE PLATE**

1-800-295-5510
uline.ca

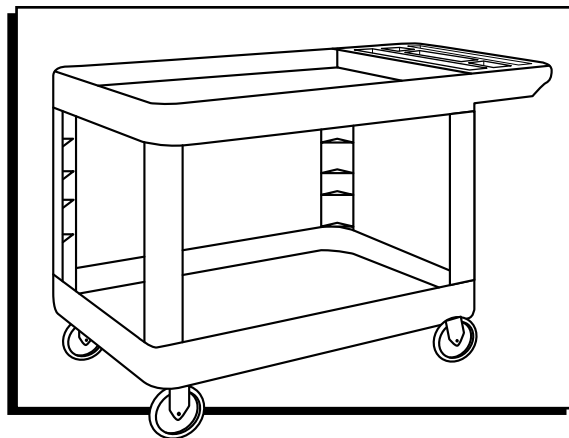

OUTILS REQUIS

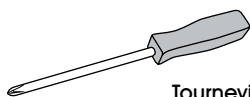

Tournevis cruciforme



Maillet en caoutchouc

PIÈCES



Roulette pivotante x 2

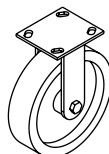

Roulette fixe x 2

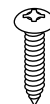

Vis x 24

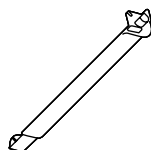

Support x 4

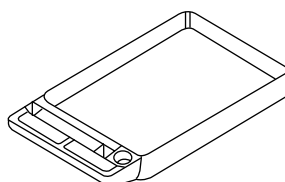

Tablette supérieure x 1

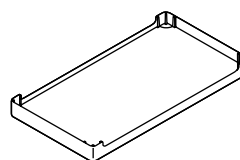

Tablette inférieure x 1

ASSEMBLAGE

Figure 1

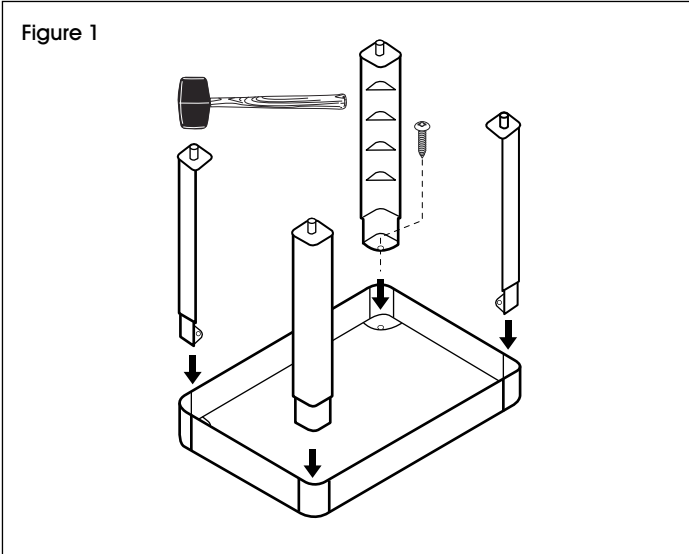

1. Introduisez les supports sur le dessus de la tablette inférieure en tapotant à l'aide du maillet en caoutchouc. Vissez les supports en place à l'aide de quatre vis. (Voir Figure 1)

Figure 2

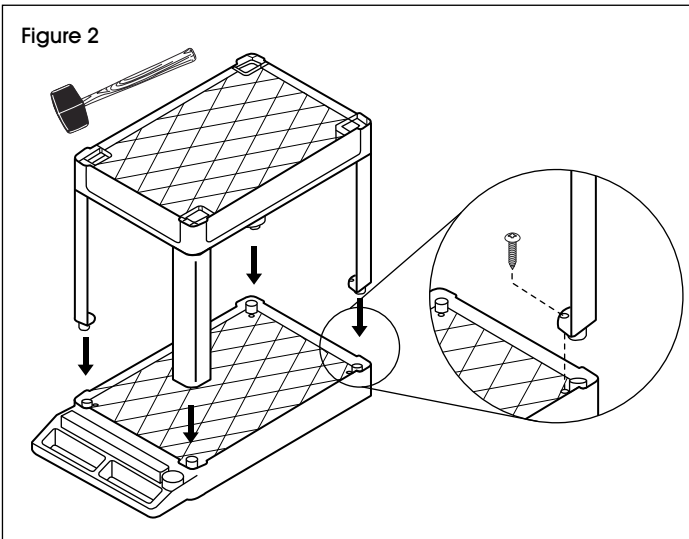

2. Retournez la tablette inférieure et emboîtez ses supports avec le côté bas de la tablette supérieure en tapotant à l'aide du maillet en caoutchouc. Vissez les supports en place à l'aide de quatre vis. (Voir Figure 2)

Figure 3

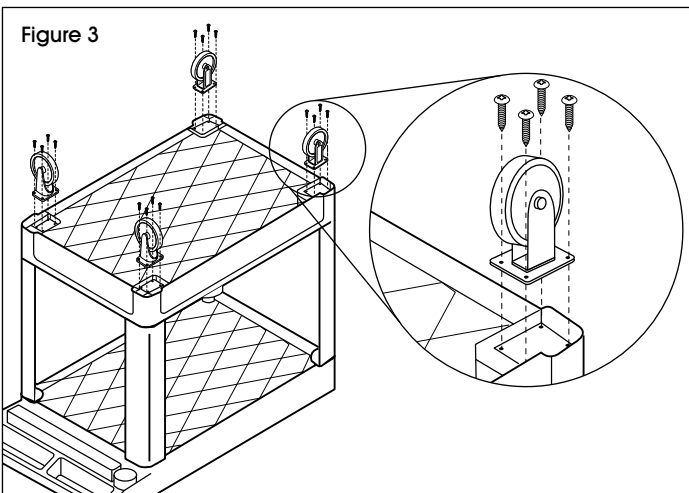

3. Vissez les roulettes sous la tablette inférieure à l'aide de 16 vis. Installez les roulettes fixes à l'avant du chariot et les roulettes pivotantes à l'arrière. (Voir Figure 3)

ULINE

1-800-295-5510
uline.ca