

ULINE H-966, H-2401

CONVERTIBLE STEEL HAND TRUCK

1-800-295-5510
uline.com

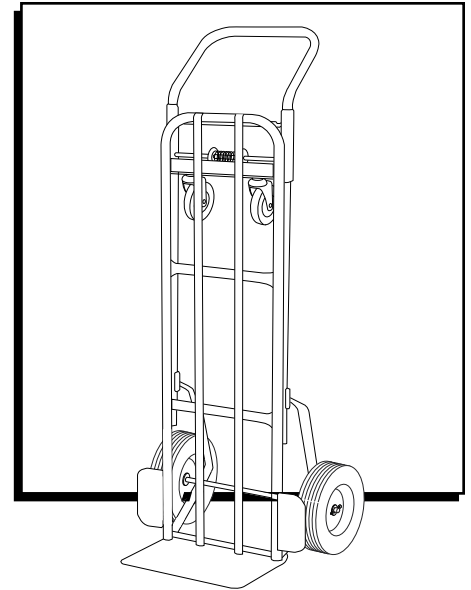

OPERATION

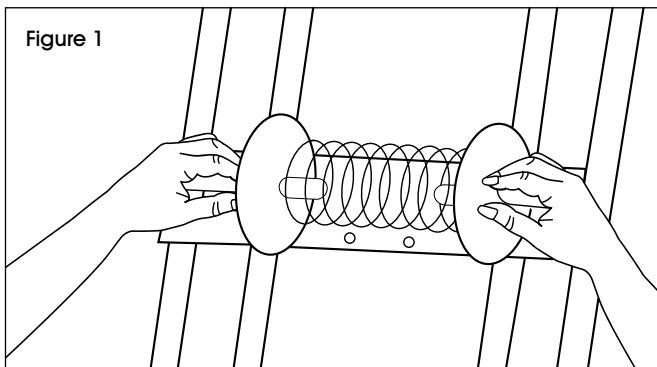

1. Facing the rear of the hand truck, squeeze spring until thumb plates hit button stops. (See Figure 1) Lift handle to fully extended position.

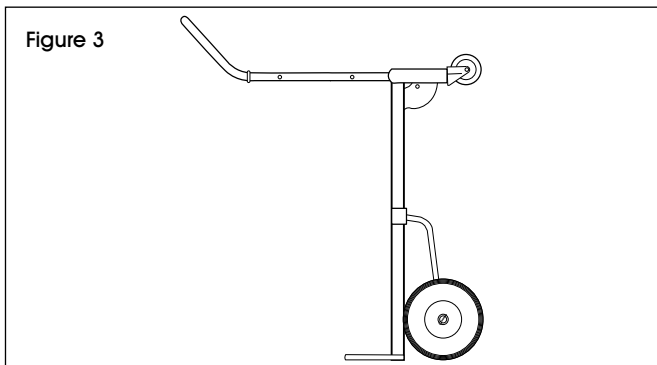

2. Holding thumb plates against button stops, swing the extended handle forward to horizontal position. (See Figure 2)



WARNING! Handle must lock in this position.

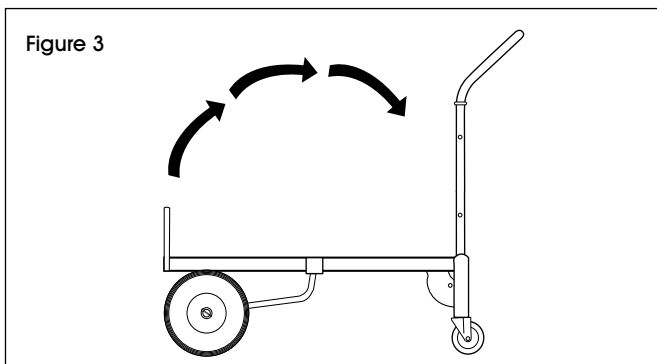

3. Carefully lower truck to four-wheel position. (See Figure 3)



NOTE: Reverse procedure to return to hand truck position.

ULINE H-966, H-2401

DIABLITO CONVERTIBLE DE ACERO

800-295-5510
uline.mx

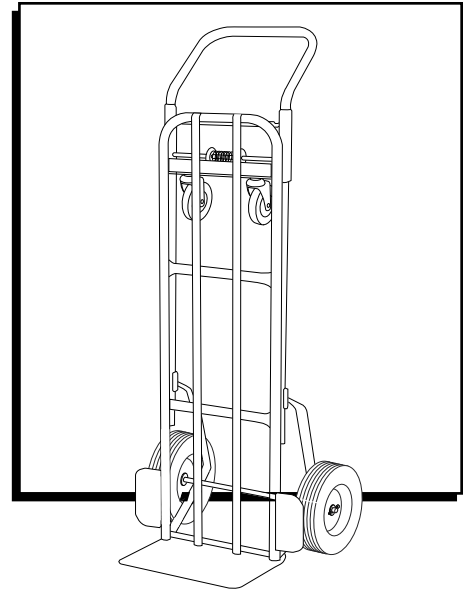

FUNCIONAMIENTO

Diagrama 1



Diagrama 3



Diagrama 3

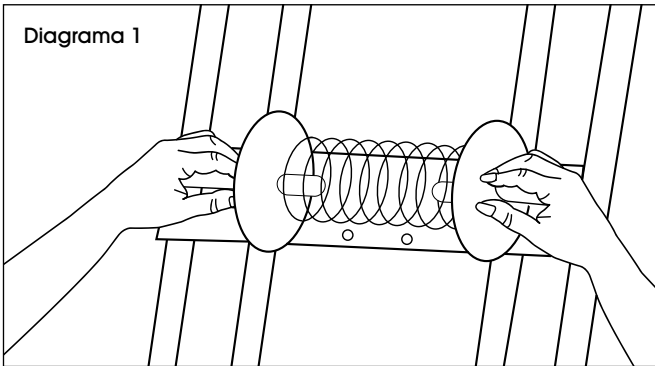

1. Mirando hacia la parte posterior del diablito, comprima el resorte hasta que las placas de los pulgares lleguen a los toques de los botones. (Vea Diagrama 1) Levante el asa hasta la posición en que quede completamente estirada.

2. Sosteniendo las placas de los pulgares contra los toques de los botones, gire el asa estirada hacia adelante para colocarla en posición horizontal. (Vea Diagrama 2)

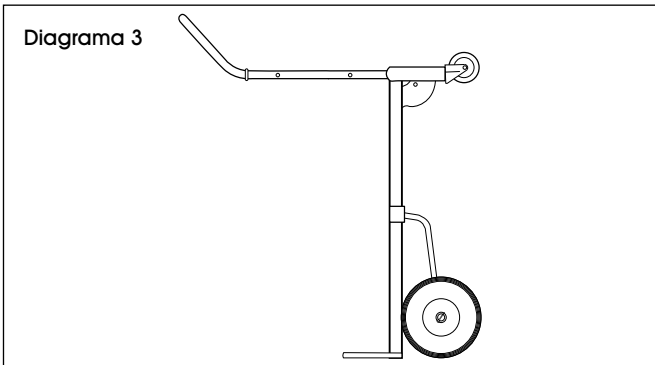
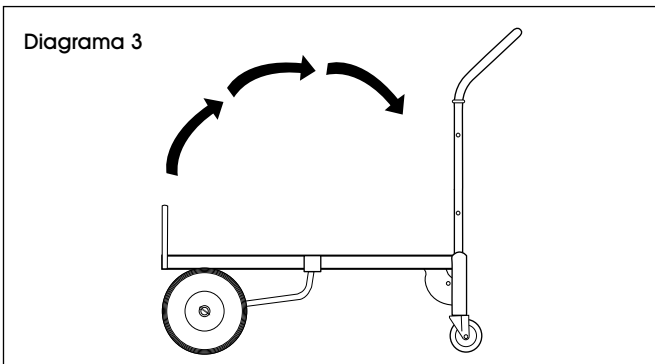

¡ADVERTENCIA! El asa deberá quedarse trabada en esta posición.

3. Con cuidado baje el diablito hasta la posición en que apoya sobre las 4 llantas. (Vea Diagrama 3)



NOTA: Realice el proceso de manera inversa para regresar a la posición de diablito.

ULINE H-966, H-2401
**DIABLE DE MANUTENTION
TRANSFORMABLE EN
ACIER**

1-800-295-5510
uline.ca

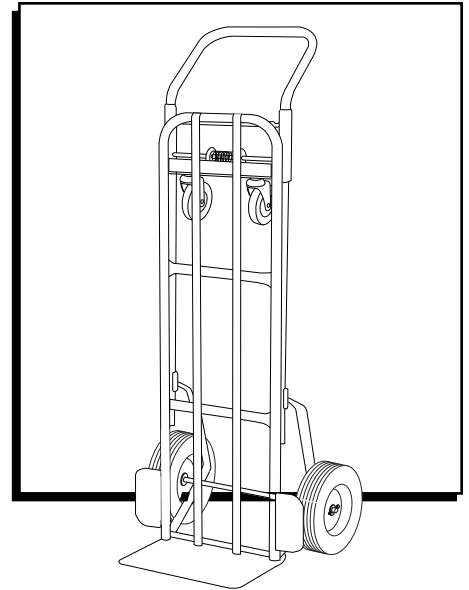

FUNCTIONNEMENT

Figure 1

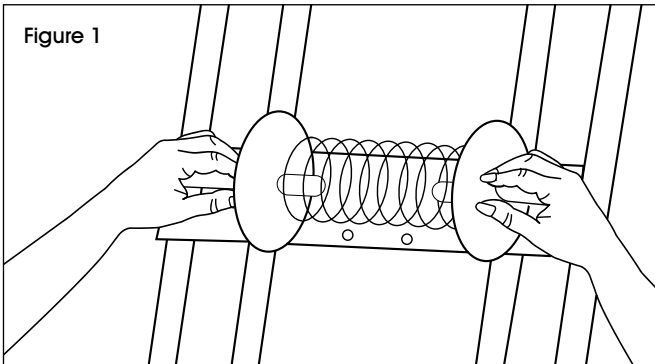

Figure 3

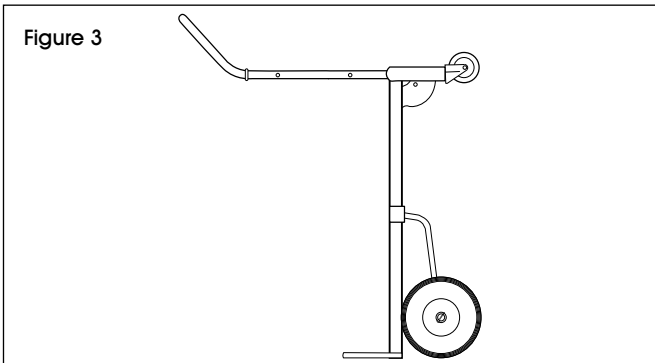
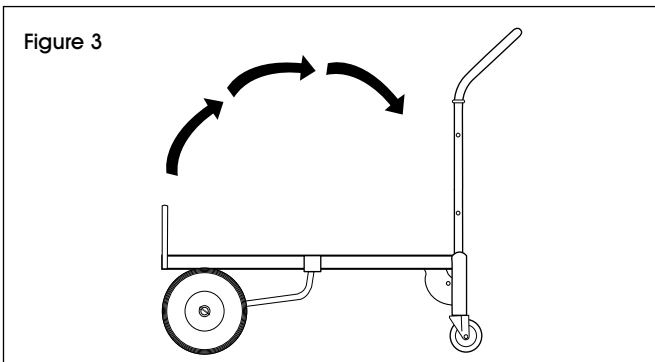

Figure 3



1. À l'arrière du diable de manutention, serrez le ressort jusqu'à ce que les plaques à tige touchent le bouton d'arrêt. (Voir Figure 1) Soulevez la poignée jusqu'à ce qu'elle soit complètement déployée.

2. En maintenant les plaques à tige appuyées contre le bouton d'arrêt, déplacez la poignée déployée vers l'avant en position horizontale. (Voir Figure 2)



AVERTISSEMENT! La poignée doit se verrouiller dans cette position.

3. Abaissez soigneusement le diable de manutention sur les quatre roues. (Voir Figure 3)



REMARQUE : Suivez la procédure inverse pour revenir à la position de diable de manutention.