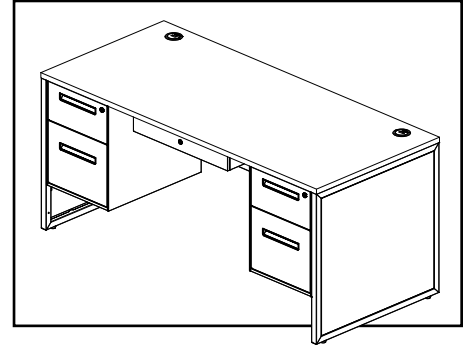
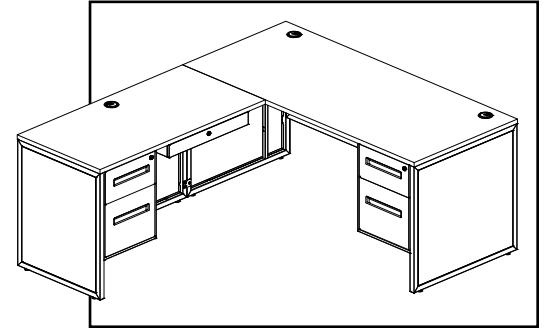

TABLE OF CONTENTS**DESK**

Pages 2-4

H-9730**L-DESK**

Pages 5-9

H-9731**U-DESK, U-DESK WITH HUTCH**

Pages 10-21

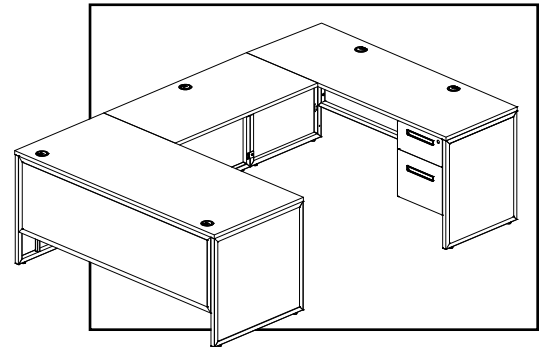
H-12038
H-12039

ULINE H-9730 OFFICE DESK

1-800-295-5510
uline.com

TOOLS NEEDED

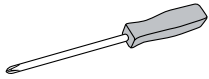

Phillips
Screwdriver



Allen Wrench
(Included)

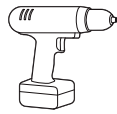

Drill
(Optional)



Two Person Assembly
Recommended

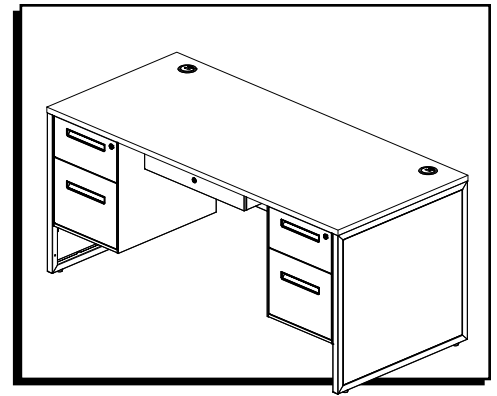

HARDWARE

A



Grommet Cap x 2

B

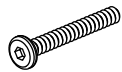

M6 x 45 mm
Bolt x 18

C

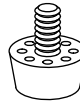

Adjustable Glide x 4

D

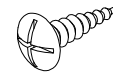

ST5 x 16 mm Wood Screw x 4

F



M6 x 15 mm Bolt x 16

I

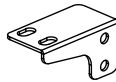

Left L-Bracket x 2

J

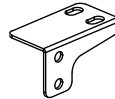

Right L-Bracket x 2

K

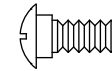

M6 x 14 mm
Shoulder Screw x 8

PARTS

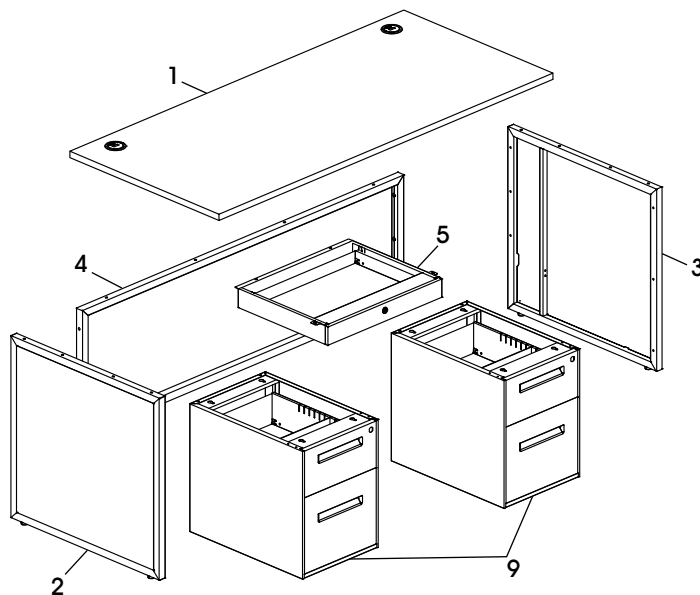

DESK PARTS

#	DESCRIPTION	QTY.
1	Desktop Panel	1
2	Left Side Panel	1
3	Right Side Panel	1
4	Modesty Panel	1
5	Center Drawer	1
9	Pedestal File	2

DESK INSTRUCTIONS



IMPORTANT! Assemble on smooth, non-marring surface to avoid scratching.

NOTE: Check that all parts are included.

NOTE: Use Allen wrench to tighten bolts.

NOTE: Use Phillips screwdriver to tighten screws.

NOTE: Adjustable glides and grommet caps come pre-attached.

1. Align modesty panel (4) with holes in side panel (2). Use three M6 x 45 mm bolts (B) to secure. Repeat for remaining side panel. (See Figure 1)

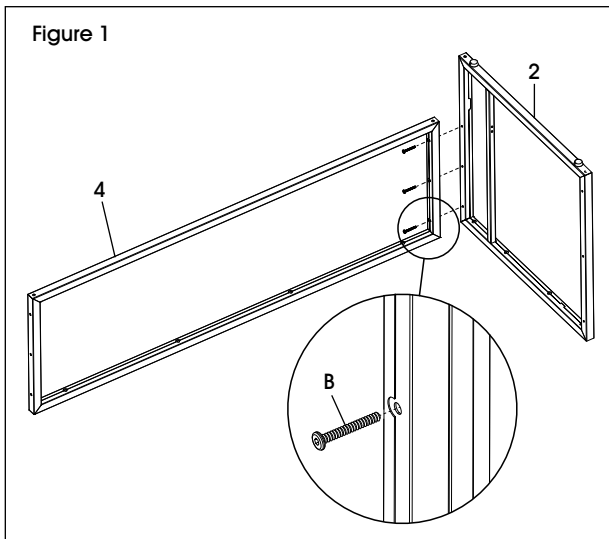

2. Place desktop panel (1) upside down on non-marring surface with holes facing up. With second person, turn assembled desk frame upside down. Use 12 M6 x 45 mm bolts (B) to secure desk frame to desktop. (See Figure 2)

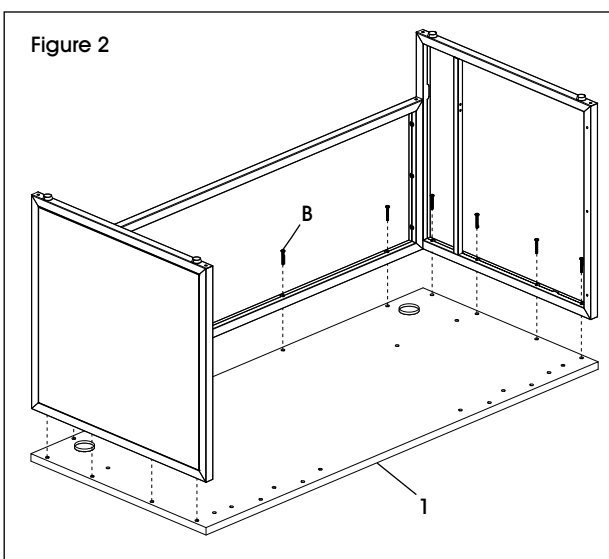

3. Insert four M6 x 14 mm shoulder screws (K) in desktop (1). (See Figure 3)



NOTE: Shoulder screws will not be flush with desktop. Screws stick out slightly from desktop for connection to pedestal file.

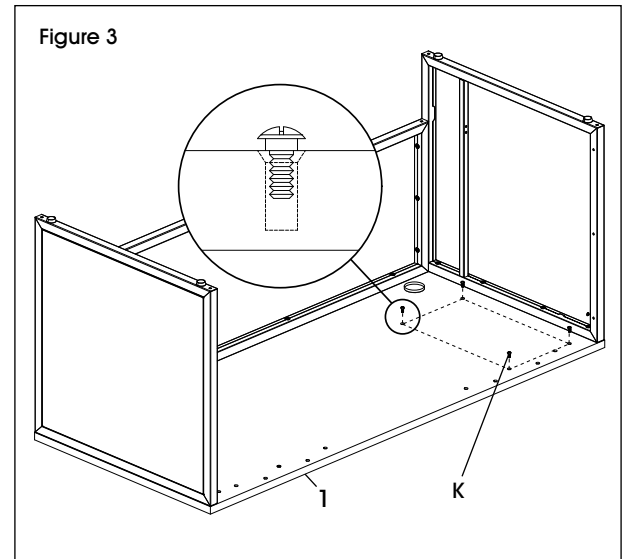

4. With second person, turn pedestal file (9) upside down. Carefully lower pedestal file and align keyhole tabs in pedestal file with shoulder screws (K) in desktop panel (1). (See Figure 4)



NOTE: Pedestal file should rest on the desktop panel and slightly hang over front edge.

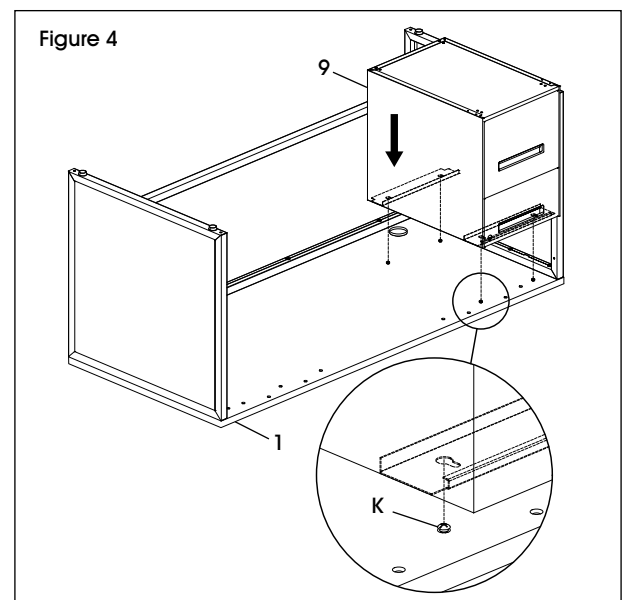

DESK INSTRUCTIONS CONTINUED

5. Push pedestal file (9) toward modesty panel (4) to hook keyhole tabs on shoulder screws (K). (See Figure 5)

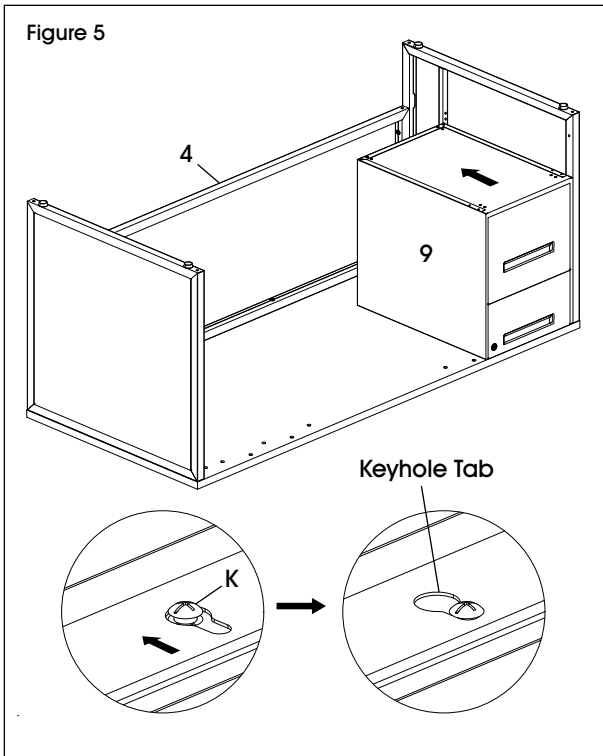

6. Attach back of pedestal file (9) to side panel with left L-Bracket (I) and four M6 x 15 mm bolts (F). Repeat at front of pedestal file with right L-Bracket (J) and four M6 x 15 mm bolts. (See Figure 6)

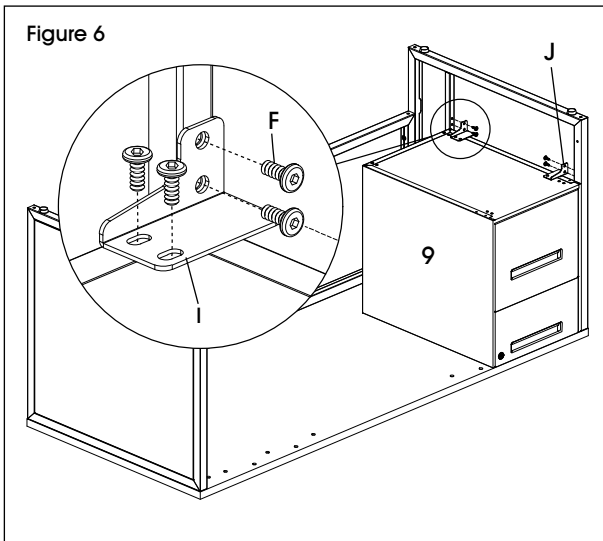

7. Repeat steps 4-7 to install remaining pedestal file on opposite side.

8. Place center drawer (5) upside down in desired location on the desktop. Use four ST 5 x 16 mm self-tapping wood screws (D) to secure. (See Figure 7)

- NOTE:** Pre-threaded holes in desktop are not used for drawer connection.
- NOTE:** Drawer holes can be started with drill (optional).
- NOTE:** It is recommended to have drawer flush with front edge of desktop panel.

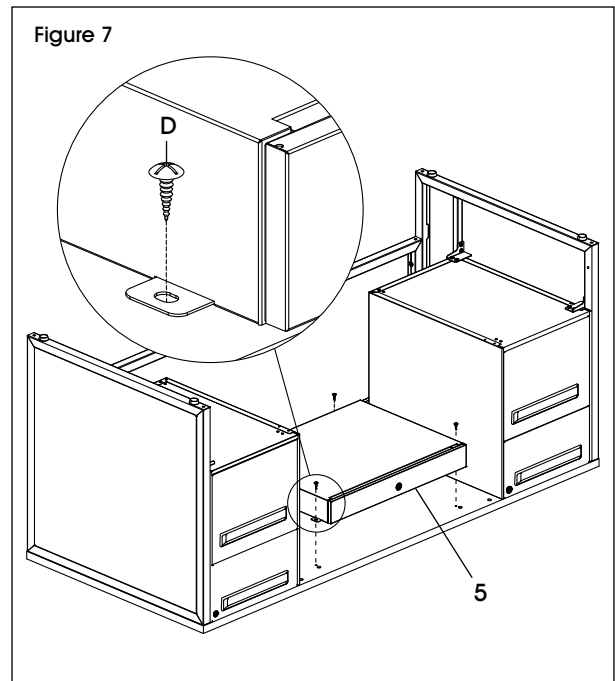

9. With second person, set desk upright. Adjust glides to compensate for uneven floors. Assembly is now complete. (See Figure 8)

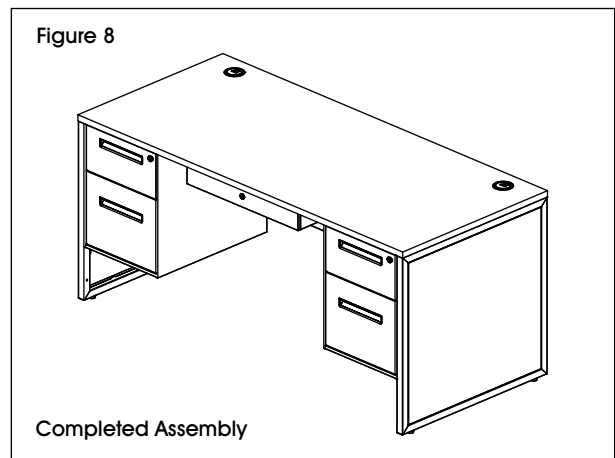

ULINE

1-800-295-5510
uline.com

ULINE H-9731 OFFICE L-DESK

1-800-295-5510
uline.com

TOOLS NEEDED

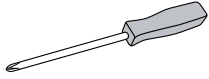

Phillips
Screwdriver



Allen Wrench
(Included)



Drill
(Optional)



Two Person Assembly
Recommended

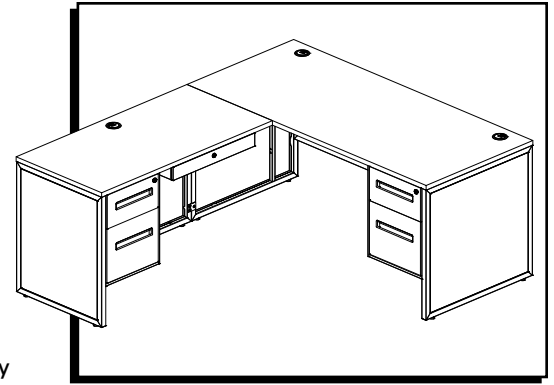

HARDWARE

A



Grommet Cap x 4

B



M6 x 45 mm
Bolt x 28

C

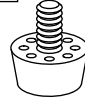

Adjustable Glide x 8

D

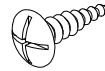

ST 5 x 16 mm
Wood Screw x 4

F

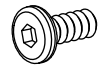

M6 x 15 mm
Bolt x 33

G

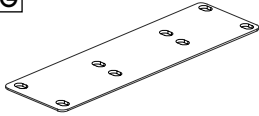

Connector Plate x 1

H

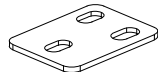

I-Bracket x 3

I

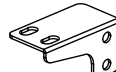

Left L-Bracket x 2

J

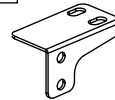

Right L-Bracket x 2

K

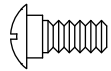

M6 x 14 mm
Shoulder Screw x 8

PARTS

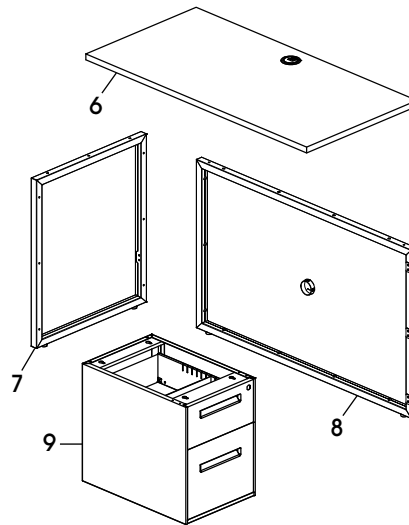
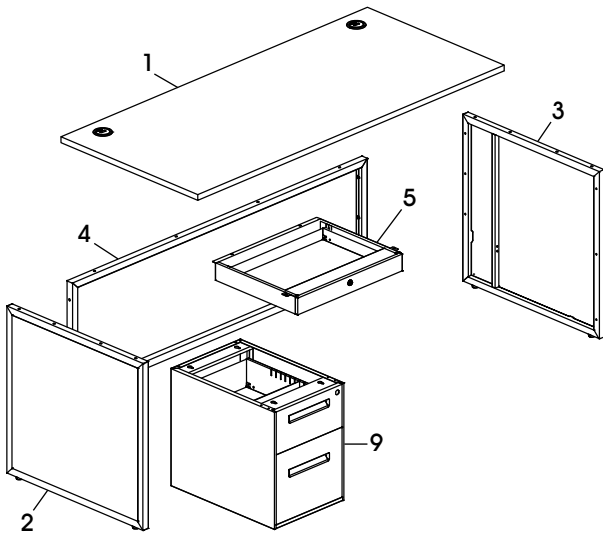

L-DESK PARTS

#	DESCRIPTION	QTY.
1	Desktop Panel	1
2	Left Side Panel	1
3	Right Side Panel	1
4	Modesty Panel	1
5	Center Drawer	1
9	Pedestal File	1

RETURN PARTS

#	DESCRIPTION	QTY.
6	Return Desktop Panel	1
7	Return Side Panel	1
8	Return Modesty Panel	1
9	Pedestal File	1

L-DESK INSTRUCTIONS



IMPORTANT! Assemble on smooth, non-marring surface to avoid scratching.

NOTE: Check that all parts are included.

NOTE: Use Allen wrench to tighten bolts.

NOTE: Use Phillips screwdriver to tighten screws.

NOTE: Adjustable glides and grommet caps come pre-attached.



STOP: Determine whether the L-desk will be set up for right-hand or left-hand configuration. This will impact how the return is assembled. Assembly of a right-hand L-desk is shown in the following figures.

3. Attach the pedestal file to the right side of the desktop (1) when it is upside down. Insert four M6 x 14 mm shoulder screws (K) into the desktop and tighten using a Phillips screwdriver. (See Figure 3)



NOTE: Shoulder screws will not be flush with desktop. Screws stick out slightly from desktop for connection to pedestal file.

DESK ASSEMBLY

1. Align modesty panel (4) with holes in side panel (2). Use three M6 x 45 mm bolts (B) to secure. Repeat for opposite side panel. (See Figure 1)

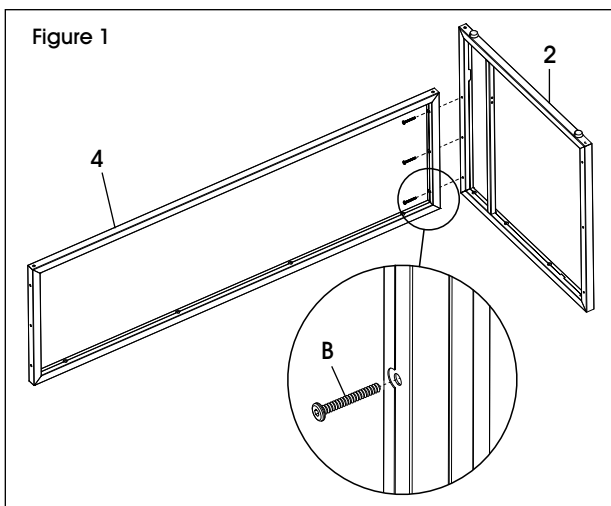

2. Place desktop panel (1) upside down on non-marring surface with holes facing up. With second person, turn assembled desk frame upside down. Use 12 M6 x 45 mm bolts (B) to secure desk frame to desktop. (See Figure 2)

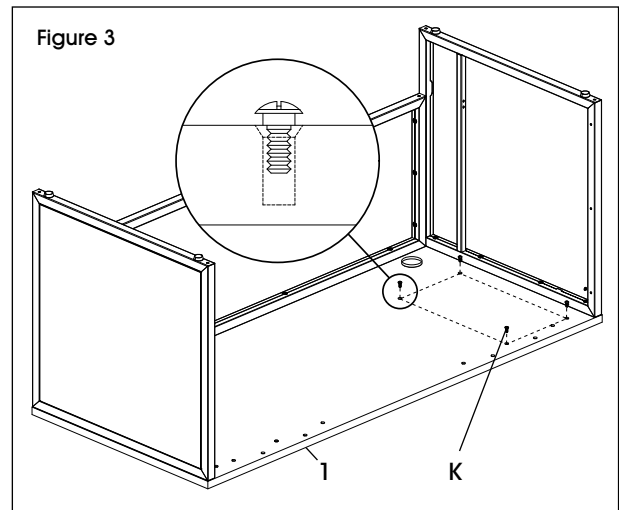
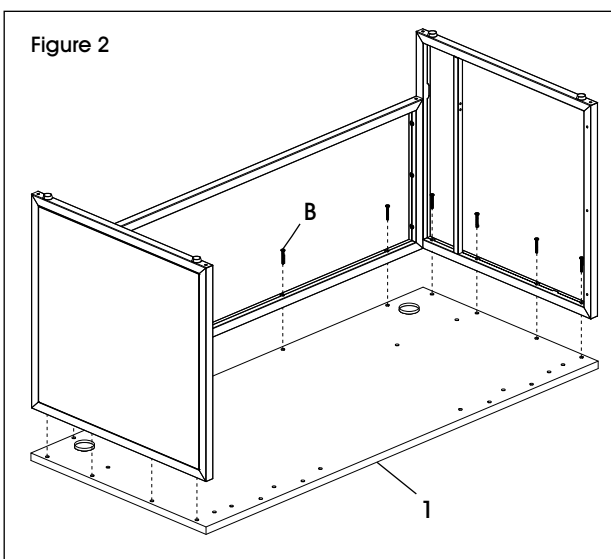

4. With second person, turn pedestal file (9) upside down. Carefully lower pedestal file and align keyhole tabs in pedestal file with shoulder screws (K) in desktop panel (1). (See Figure 4)



NOTE: Pedestal file should rest on the desktop panel and slightly hang over front edge.

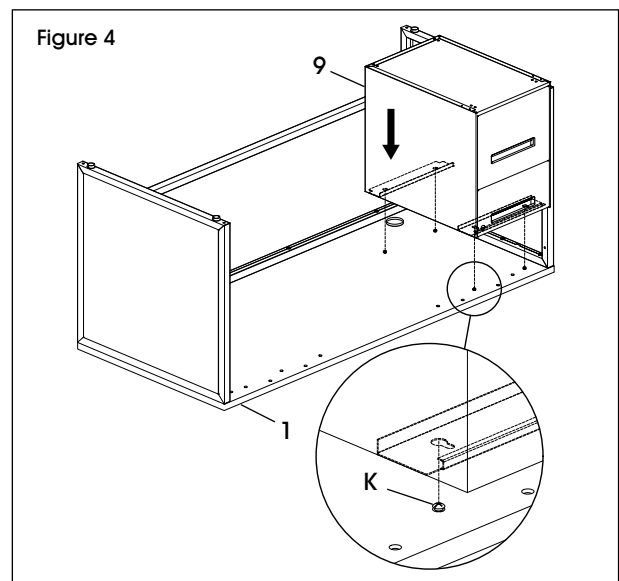

L-DESK INSTRUCTIONS CONTINUED

- Attach back of pedestal file (9) to side panel with left L-Bracket (I) and four M6 x 15 mm bolts (F). Repeat at front of pedestal file with right L-Bracket (J) and four M6 x 15 mm bolts. (See Figure 5)

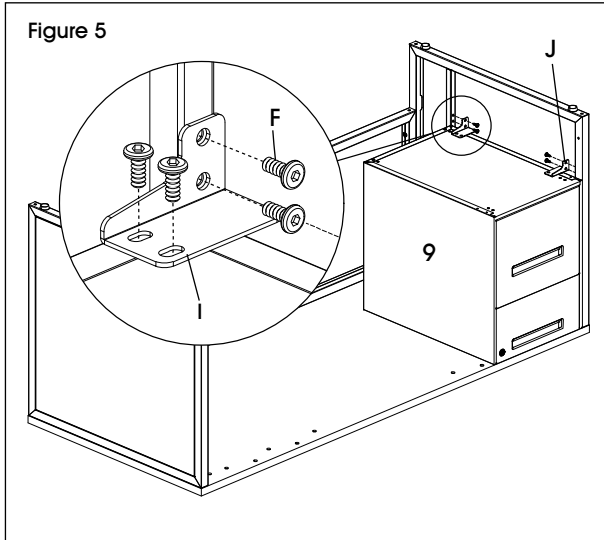

- Attach connector plate (G) to desktop panel (1) with four M6 x 15 mm bolts (F). (See Figure 6)

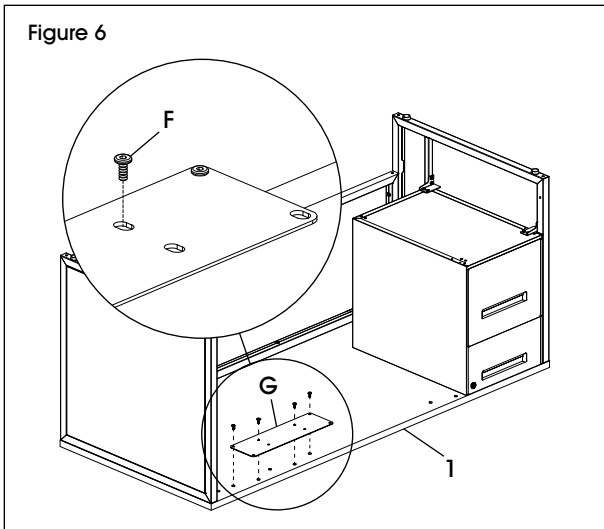

- With second person, set desk upright.

 **NOTE:** Before proceeding, ensure desk is positioned where it is intended to be used. It is difficult to move when fully assembled.

RETURN ASSEMBLY

- Align return modesty panel (8) with holes in return side panel (7). Use three M6 x 45 mm bolts (B) to secure. (See Figure 7)

 **NOTE:** For left-hand L-desk configuration, return side panel should be attached to opposite side of the return modesty panel.

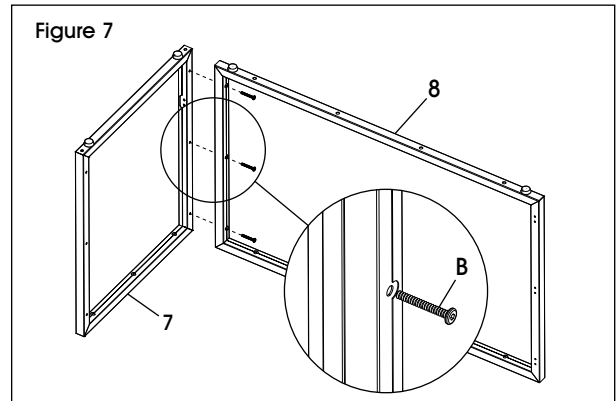

- Place return desktop panel (6) upside down with holes facing up. With second person, turn assembled L-desk frame upside down. Use seven M6 x 45 mm bolts (B) to secure desk frame to desktop. (See Figure 8)

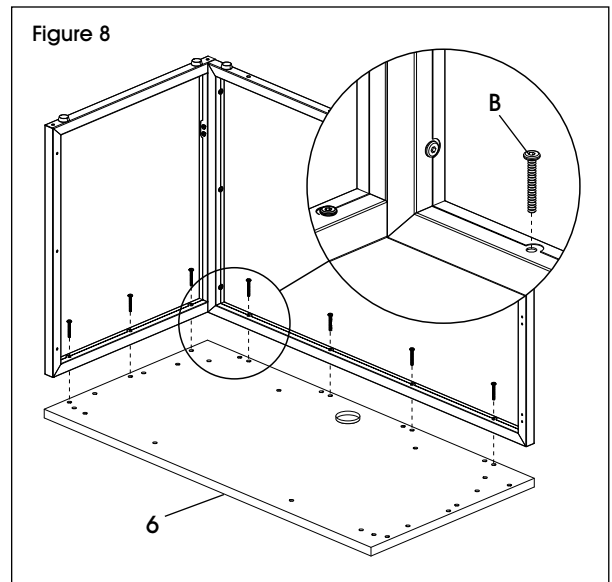

L-DESK INSTRUCTIONS CONTINUED

3. Install four M6 x 14 mm pedestal file shoulder screws (K) in return desktop panel (6). (See Figure 9)

 **NOTE:** Shoulder screws (K) will not be flush with desktop (6). Screws stick out slightly from desktop for connection to pedestal file.

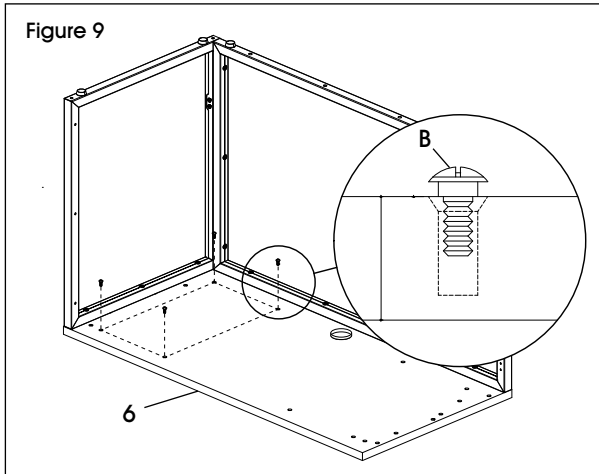

4. With second person, turn pedestal file (9) upside down. Carefully lower pedestal file and align keyhole tabs in pedestal file with shoulder screws (K) in return desktop panel (6). (See Figure 10)

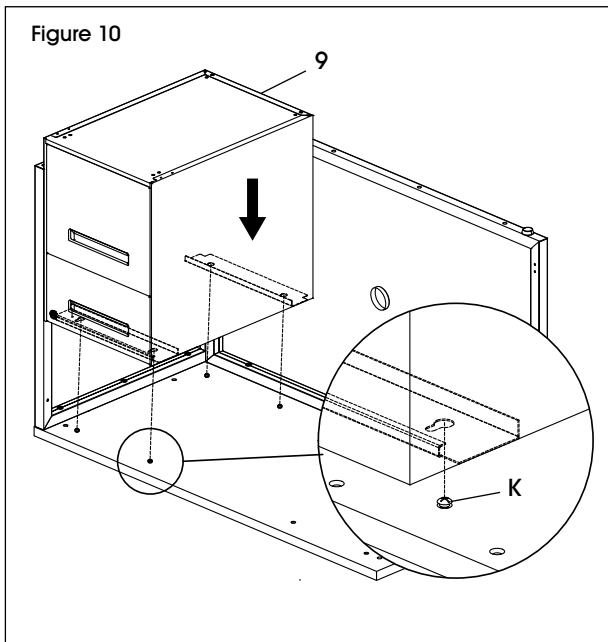

5. Push pedestal file (9) toward return modesty panel (8) to hook keyhole tabs on shoulder screws (K). (See Figure 11)

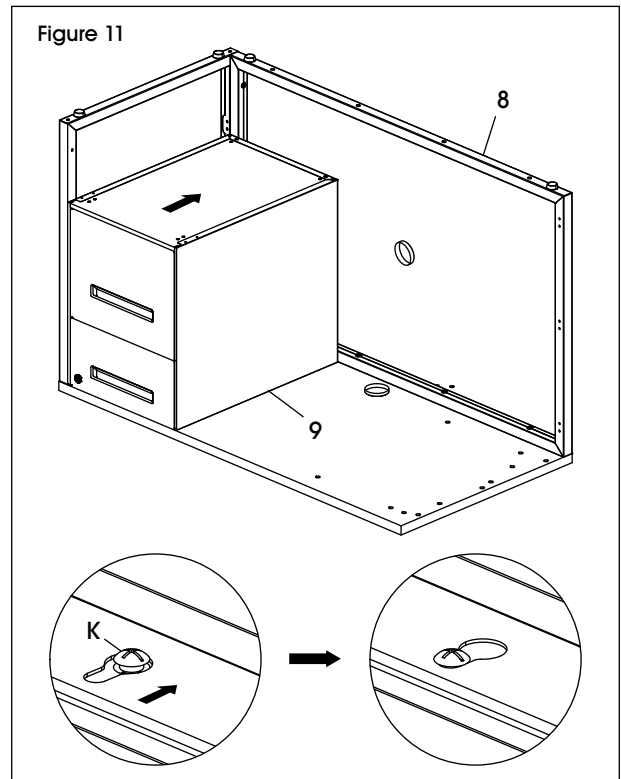

6. Attach back of pedestal file (9) to return side panel with right L-Bracket (J) and four M6 x 15 mm bolts (F). Repeat at front of pedestal file with left L-Bracket and four M6 x 15 mm bolts. (See Figure 12)

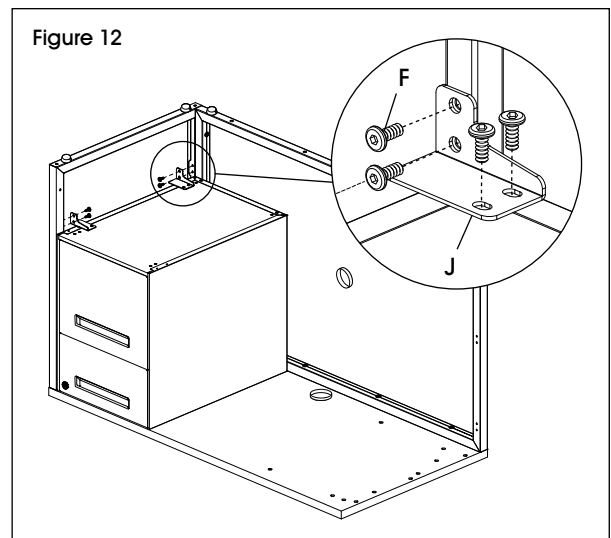

L-DESK INSTRUCTIONS CONTINUED

FINAL ASSEMBLY

1. With second person, set L-desk return upright and position next to assembled desk. Attach connector plate (G) to return desktop panel (6) with four M6 x 15 mm bolts (F). (See Figure 13)

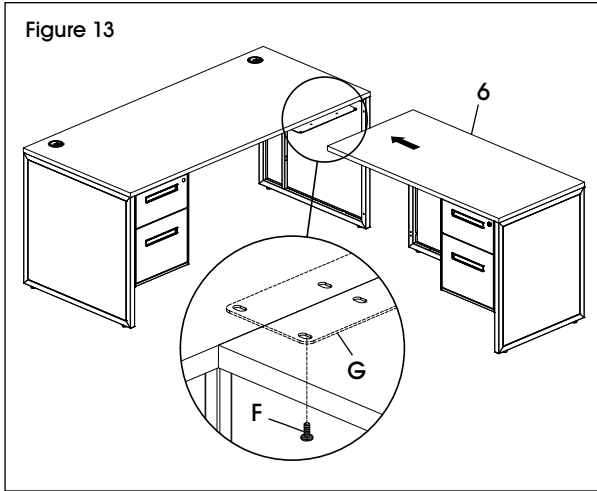

2. Attach one I-bracket (H) with three M6 x 15 mm bolts (F) to secure return modesty panel to adjacent side panel. Repeat for two remaining I-brackets. (See Figure 14)

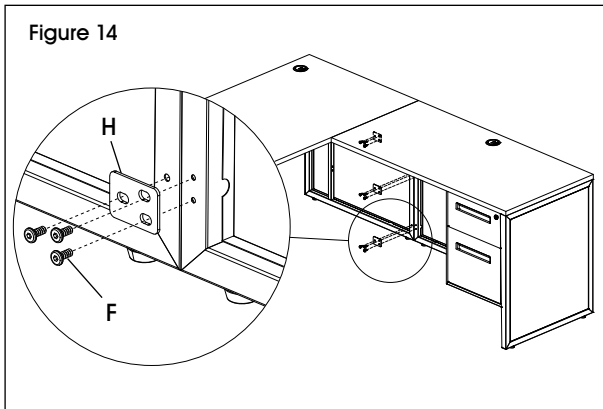

3. With second person, hold center drawer (5) in the desired location on the desktop or return top. Use four ST 5 x 16 mm self-tapping wood screws (D) to secure. (See Figure 15)



NOTE: Pre-threaded holes in desktop are not used for drawer connection.



NOTE: Drawer holes can be started with drill. (optional)



NOTE: It is recommended to have drawer flush with front edge of desktop panel.

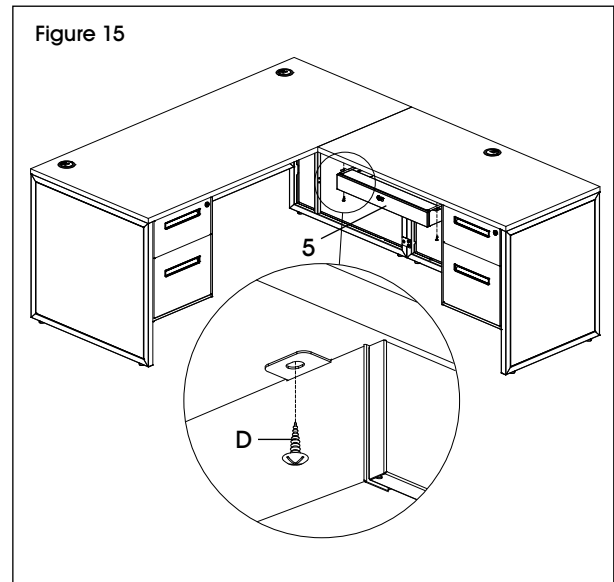

4. Adjust glides to compensate for uneven floors. Assembly is now complete. (See Figure 16)

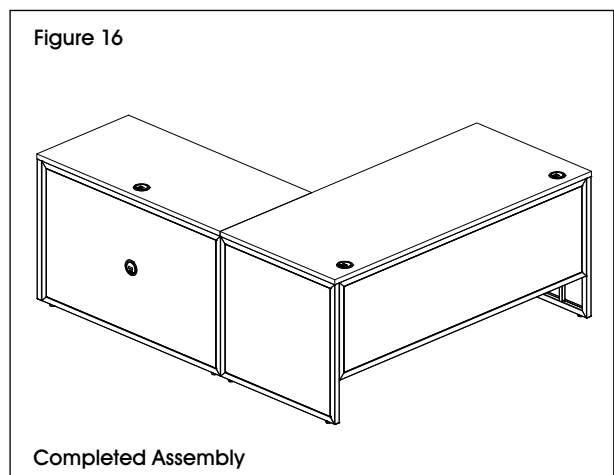

ULINE

1-800-295-5510

uline.com

ULINE H-12038, H-12039

U-DESK

1-800-295-5510
uline.com

TOOLS NEEDED

 Two Person Assembly Recommended

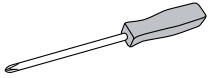
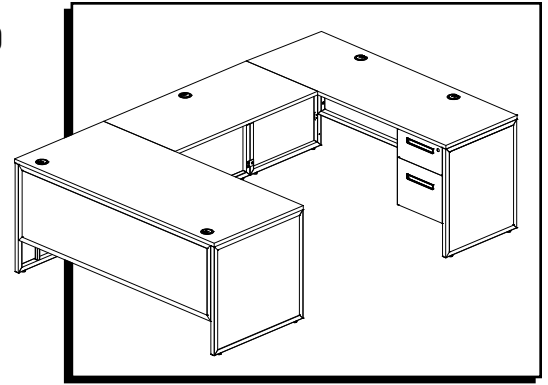

Phillips
Screwdriver

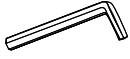

Allen Wrench
(Included)

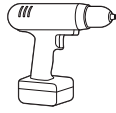

Drill
(Optional)



Rubber Mallet

HARDWARE

A



Grommet Cap x 6

B

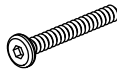

M6 x 45 mm
Bolt x 36

C

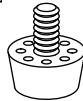

Adjustable Glide x 10

D

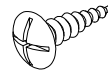

ST 5 x 16 mm
Wood Screw x 4

F



M6 x 15 mm
Bolt x 50

G

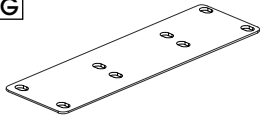

Connector Plate x 2

H

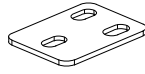

I-Bracket x 6

I



Left L-Bracket x 2

J

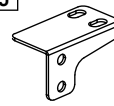

Right L-Bracket x 2

K

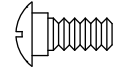

M6 x 14 mm
Shoulder Screw x 8

PARTS

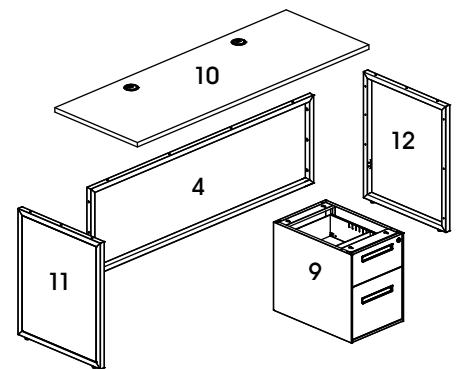
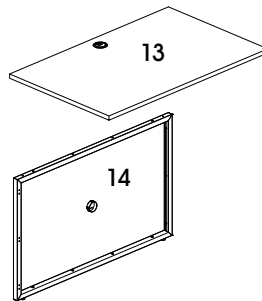
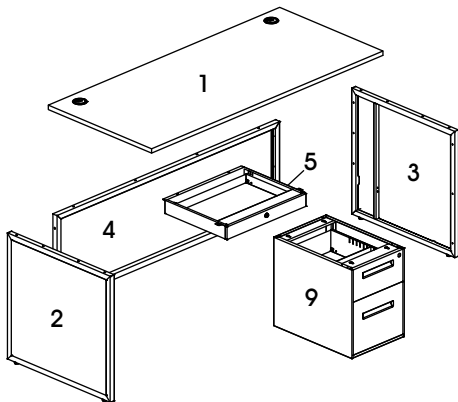

DESK PARTS

#	DESCRIPTION	QTY.
1	66 x 30" Desktop Panel	1
2	30" W Left Side Panel	1
3	30" W Right Side Panel	1
4	Modesty Panel	1
5	Center Drawer	1
9	Pedestal File	1

BRIDGE PARTS

#	DESCRIPTION	QTY.
13	Bridge Desktop Panel	1
14	Bridge Modesty Panel	1

CREDENZA PARTS

#	DESCRIPTION	QTY.
4	Modesty Panel	1
9	Pedestal File	1
10	66 x 24" Credenza Top Panel	1
11	24" W Left Side Panel	1
12	24" W Right Side Panel	1

U-DESK INSTRUCTIONS



IMPORTANT! Assemble on smooth, non-marring surface to avoid scratching.

NOTE: Check that all parts are included.

NOTE: Use Allen wrench to tighten bolts.

NOTE: Use Phillips screwdriver to tighten screws.

NOTE: Adjustable glides and grommet caps come pre-attached.

DESK ASSEMBLY

1. Align modesty panel (4) with holes in 30" side panel (2). Use three M6 x 45 mm bolts (B) to secure. Repeat with second side panel. (See Figure 1)

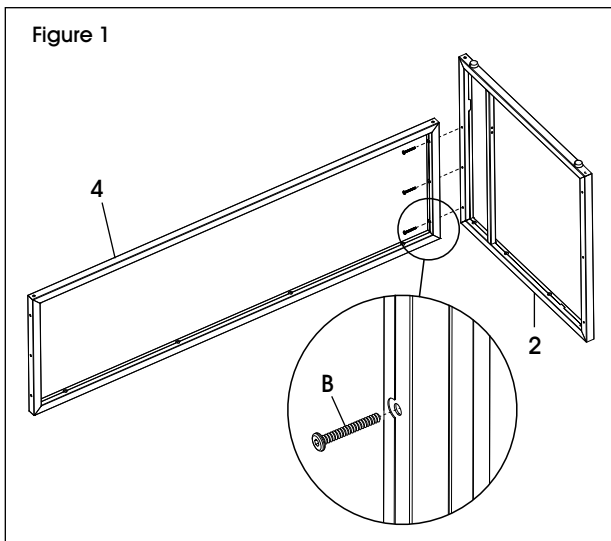

2. Place 66 x 30" desktop panel (1) upside down with holes facing up. With second person, turn assembled desk frame upside down. Use 12 M6 x 45 mm bolts (B) to secure desk frame to desktop. (See Figure 2)

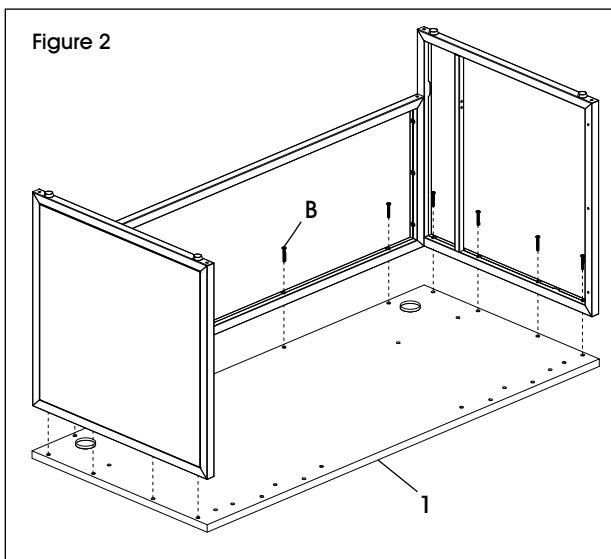

STOP: Determine whether the U-desk will be set up for right-hand or left-hand configuration. Assembly of a right-hand U-desk is shown in the following figures.

3. Insert four M6 x 14 mm shoulder screws (K) into the desktop (1) and tighten using a Phillips screwdriver. (See Figure 3)



NOTE: For left-hand L-desk configuration, insert screws onto opposite side of desktop.



NOTE: Shoulder screws will not be flush with desktop. Screws stick out slightly from desktop for connection to pedestal file.

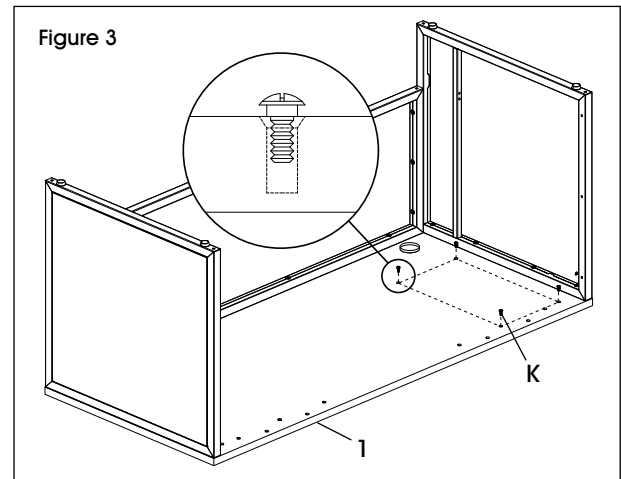

4. With second person, turn pedestal file (9) upside down. Carefully lower pedestal file and align keyhole tabs in pedestal file with shoulder screws (K) in desktop panel (1). (See Figure 4)



NOTE: Pedestal file should rest on the desktop panel and slightly hang over front edge.

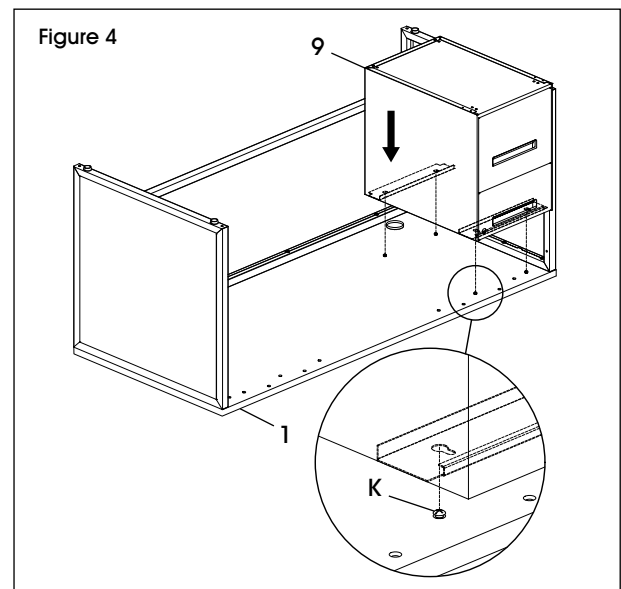

U-DESK INSTRUCTIONS CONTINUED

5. Push pedestal file (9) toward modesty panel (4) to hook keyhole tabs on shoulder screws (K). (See Figure 5)

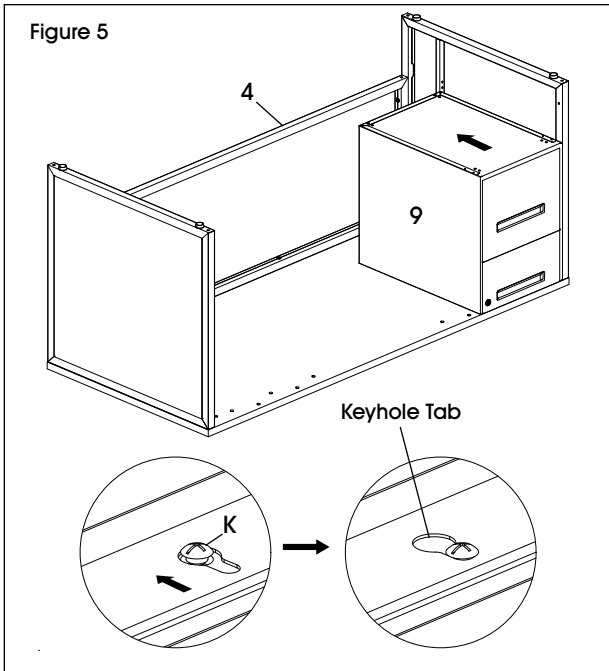

6. Attach back of pedestal file (9) to side panel with left L-Bracket (I) and four M6 x 15 mm bolts (F). Repeat at front of pedestal file with right L-Bracket (J) and four M6 x 15 mm bolts. (See Figure 6)

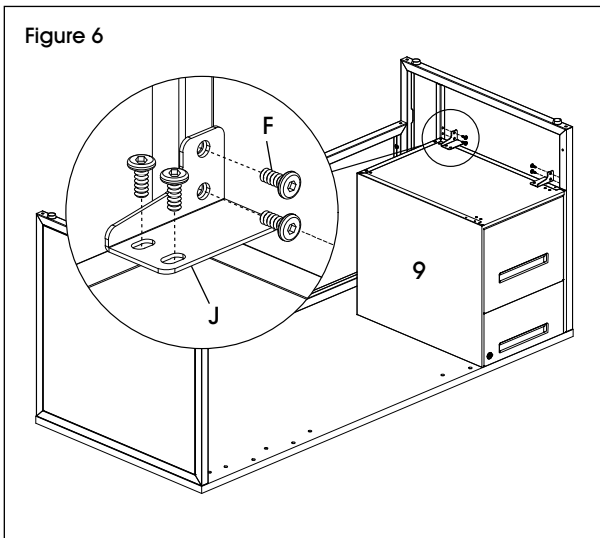

7. Place center drawer (5) upside down in desired location on desktop. Use four ST 5 x 6 mm wood screws (D) to secure. (See Figure 7)



NOTE: Pre-threaded holes in desktop are not used for drawer connection.



NOTE: Drawer holes can be started with drill (optional).



NOTE: It is recommended to have drawer flush with front edge of desktop panel.

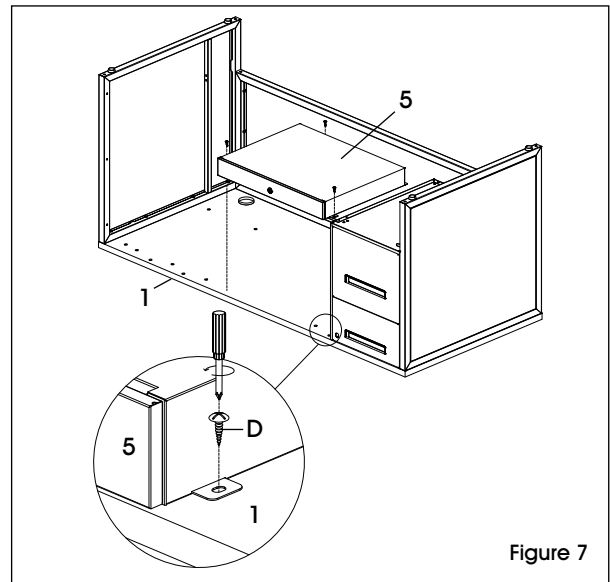

8. Attach connector plate (G) to desktop panel (1) using four M6 x 15 mm bolts (F). (See Figure 8)

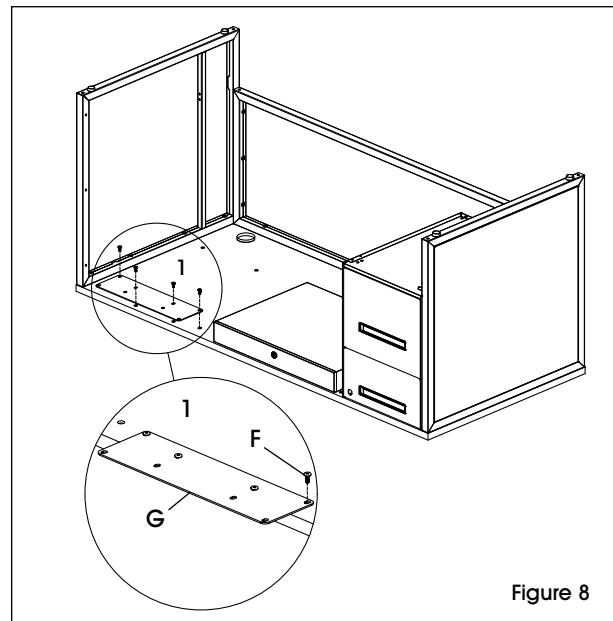

U-DESK INSTRUCTIONS CONTINUED

BRIDGE ASSEMBLY

Attach bridge modesty panel (14) to bridge desktop panel (13) using four M6 x 45 mm bolts (B). (See Figure 9)

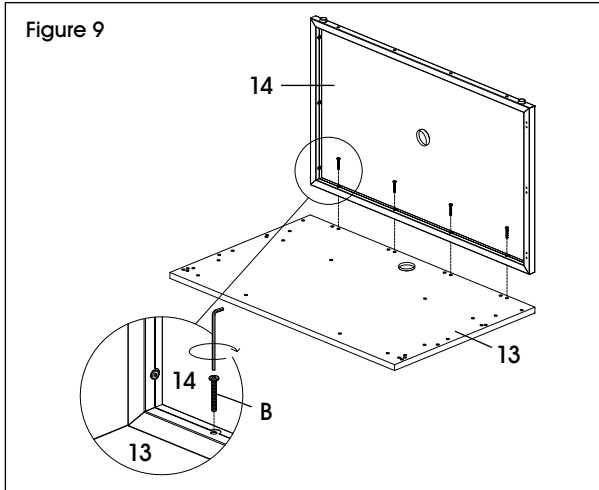

CREDENZA ASSEMBLY

1. Align modesty panel (4) with holes in left 24" side panel (11). Use three M6 x 45 mm bolts (B) to secure. Repeat with right 24" panel (12). (See Figure 10)

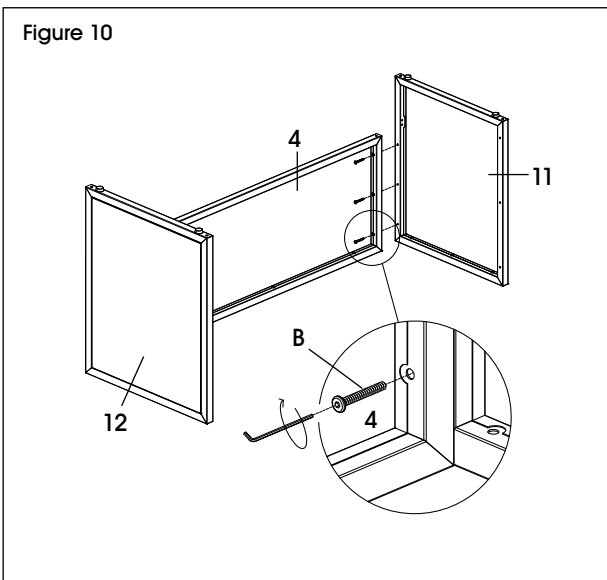

2. Place 66 x 24" credenza top panel (10) upside down with holes facing up. With second person, turn assembled credenza frame upside down and align with holes in credenza top panel. Use 12 M6 x 45 mm bolts (B) to secure. (See Figure 11)

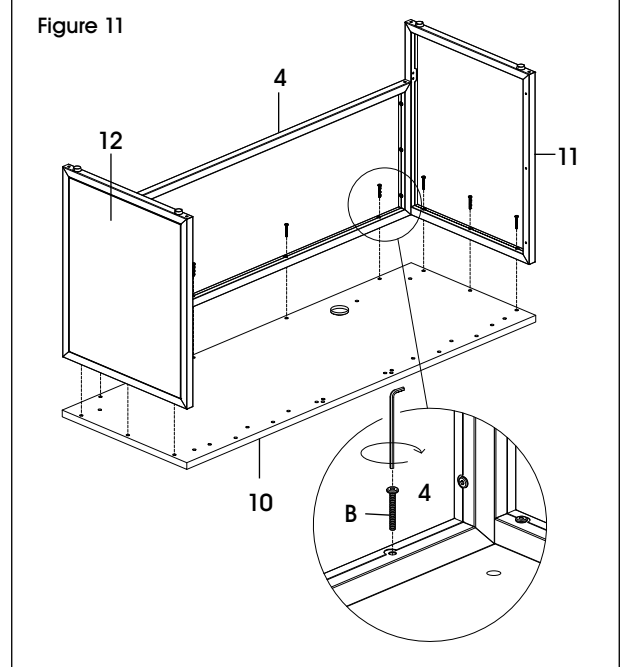

3. Insert four M6 x 14 mm shoulder screws (K) in credenza top panel (10). (See Figure 12)

 **NOTE:** Shoulder screws will not be flush with desktop. Screws stick out slightly from desktop for connection to pedestal file.

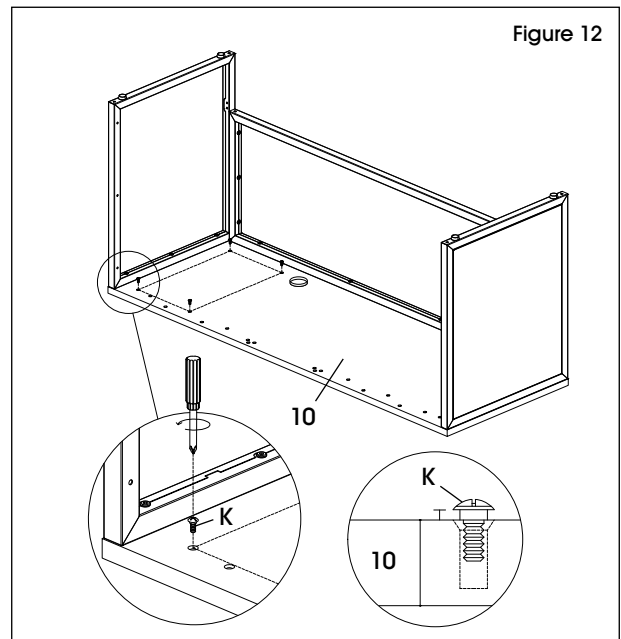

U-DESK INSTRUCTIONS CONTINUED

- With a second person, turn pedestal file (9) upside down. Carefully lower and align keyhole tabs in pedestal file with shoulder screw (K) in credenza top panel (10). (See Figure 13)

 **NOTE:** Pedestal file should rest on the credenza top panel and slightly overhang front edge.

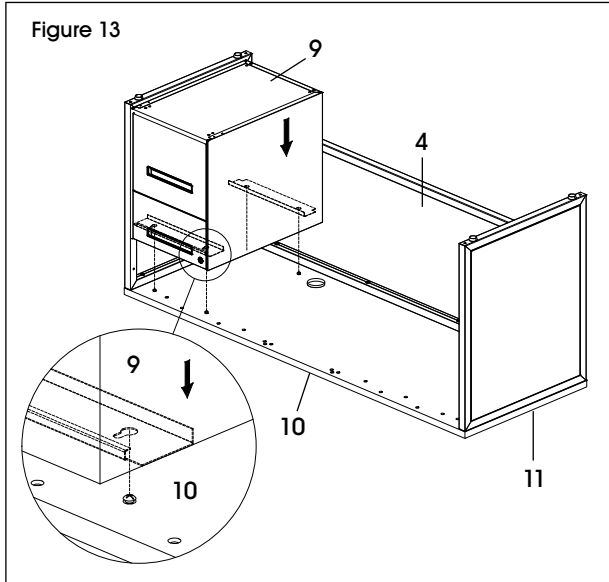

- Push pedestal file (9) toward modesty panel (4) to hook keyhole tabs on shoulder screws (K). (See Figure 14)

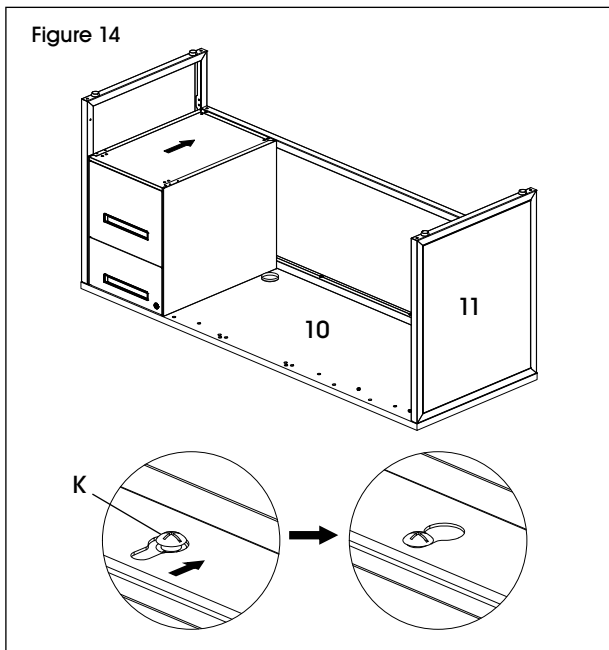

- Attach back of pedestal file (9) to side panel with right L-Bracket (J) and four M6 x 15 mm bolts (F). Repeat at front of pedestal file with left L-Bracket (I) and four M6 x 15 mm bolts. (See Figure 15)

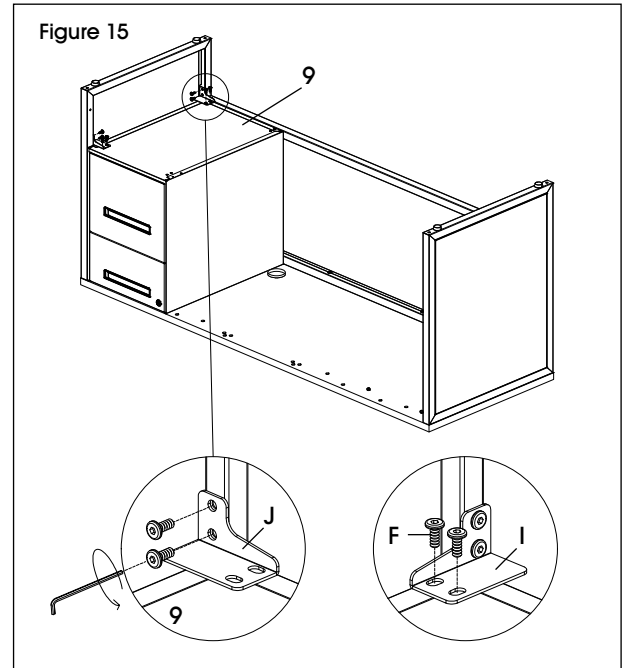

- Install connector plate (G) to credenza top panel (10) using four M6 x 15 mm bolts (F). (See Figure 16)

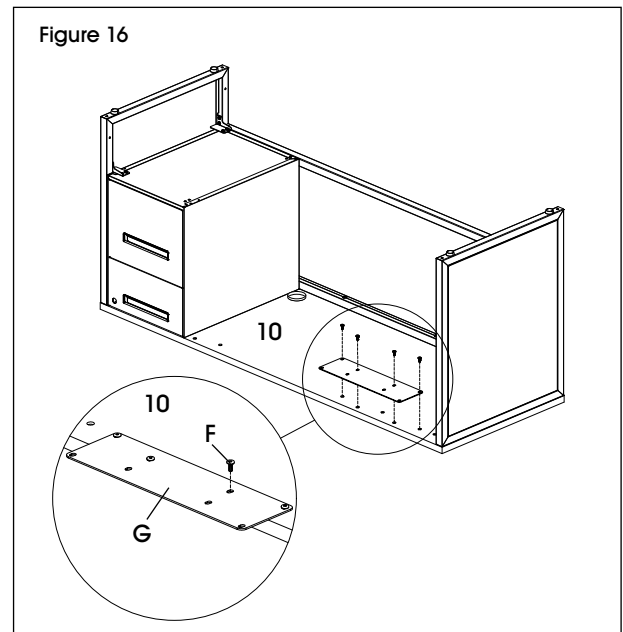

U-DESK INSTRUCTIONS CONTINUED

FINAL ASSEMBLY

 **NOTE:** Position assembled components near desired location.

1. With second person, set assembled credenza upright. Attach connector plate (G) on credenza to bridge top panel (13) using four M6 x 15 mm bolts (F). (See Figure 17)

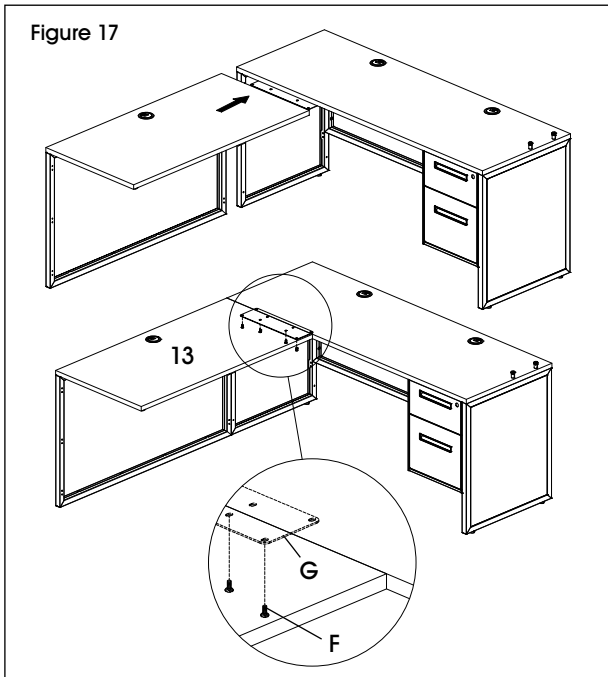

2. Attach one I-Bracket (H) with three M6 x 15 mm bolts (F) to secure the bridge modesty panel to adjacent credenza side panel. Repeat for two remaining I-Brackets. (See Figure 18)

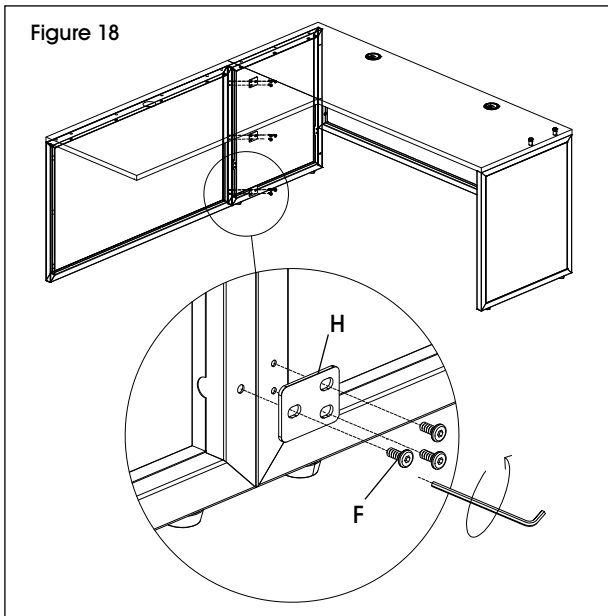

3. With second person, set assembled desk upright and position next to bridge. Attach connector plate (G) to bridge top panel (13) using four M6 x 15 mm bolts (F). (See Figure 19)

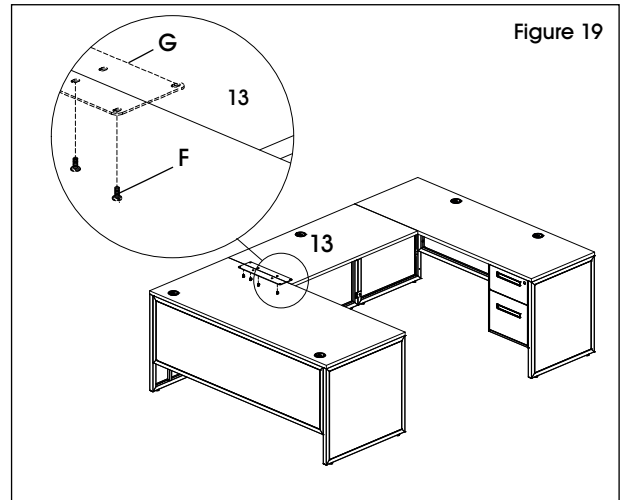

4. Secure bridge to modesty panel (14) and adjacent desk side panel with I-Bracket (H) and three M6 x 15 mm bolts (F). Repeat for two remaining I-Brackets. (See Figure 20)

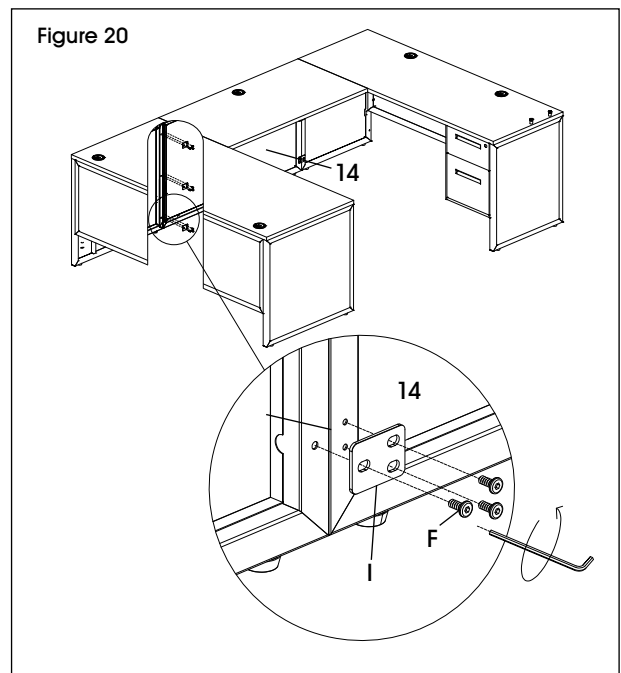

 **STOP!** If assembling hutch, proceed to next page. If not, assembly is complete.

HUTCH HARDWARE

B

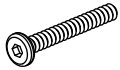

M6 x 45 mm
Bolt x 36

F



M6 x 15 mm
Bolt x 32

M

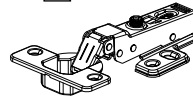

Hinge x 4

N



ST 3.5 x 14 mm
Hinge Screw x 8

O



M4 x 10 mm
Hinge Bolt x 8

P

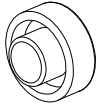

Door Wheel x 4

Q

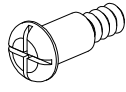

M6 x 14 mm
Door Bolt x 4

R

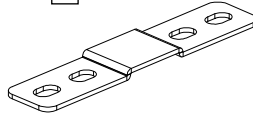

Hutch Bracket x 2

S

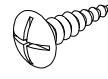

ST 4 x 18 mm
Wood Screw x 4

T

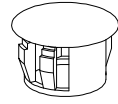

Plastic Cap x 4

Lock and Keys Set x 2

U



Screw x 1

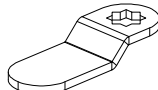

Lock Plate x 1

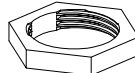

Hex Nut x 1

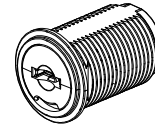

Cylinder x 1

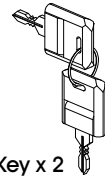

Key x 2

HUTCH PARTS

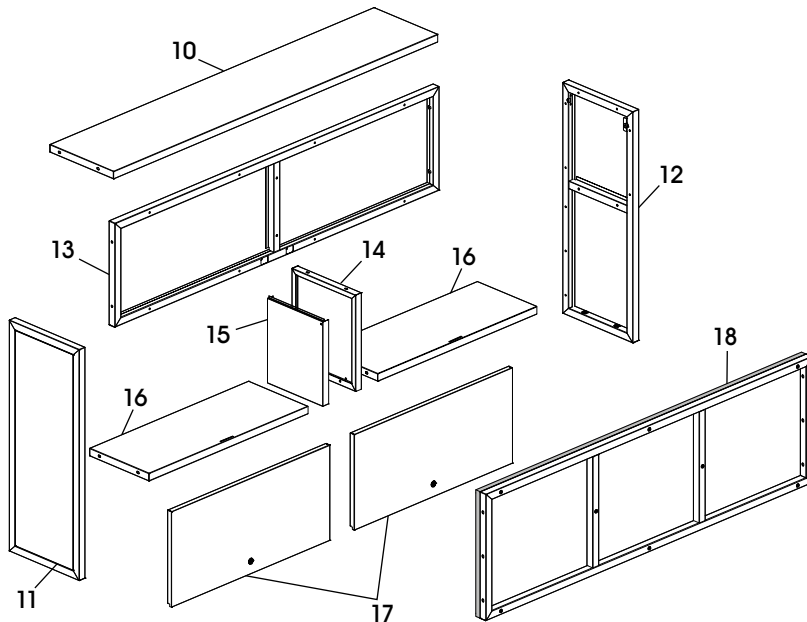

HUTCH PARTS

#	DESCRIPTION	QTY.
10	Top Panel	1
11	Left Side Panel	1
12	Right Side Panel	1
13	Back Panel	1
14	Outer Divider Panel	1
15	Inner Divider Panel	1
16	Bottom Panel	2
17	Door	2
18	Tackboard	1

HUTCH INSTRUCTIONS

ASSEMBLY

1. Place top panel (10) upside down. Align back panel (13) with holes in top panel. Loosely tighten four M6 x 15 mm bolts (F). (See Figure 21)

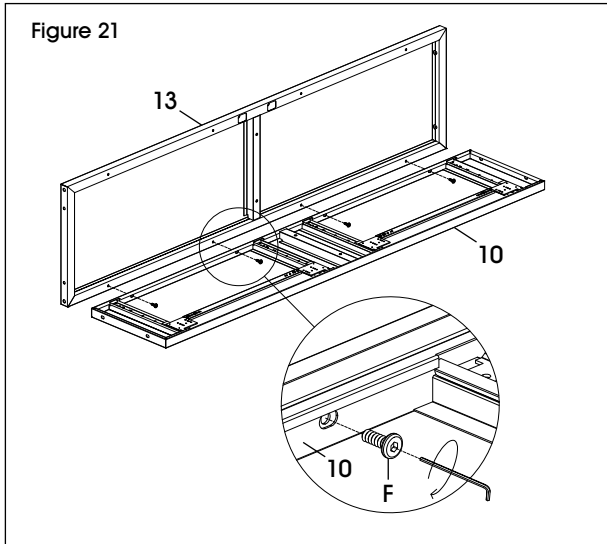

2. Partially insert two M6 x 15 mm bolts (F) into left side panel (11). Approximately 1/8" of space should remain between bolt heads and panel. Align bolts in left side panel with keyhole tabs in top panel (10). Insert both bolts through keyhole tabs. Pull left side panel toward front of top panel to lock bolts into keyhole tabs. Fully tighten bolts. Repeat for right side panel (12). (See Figure 22)

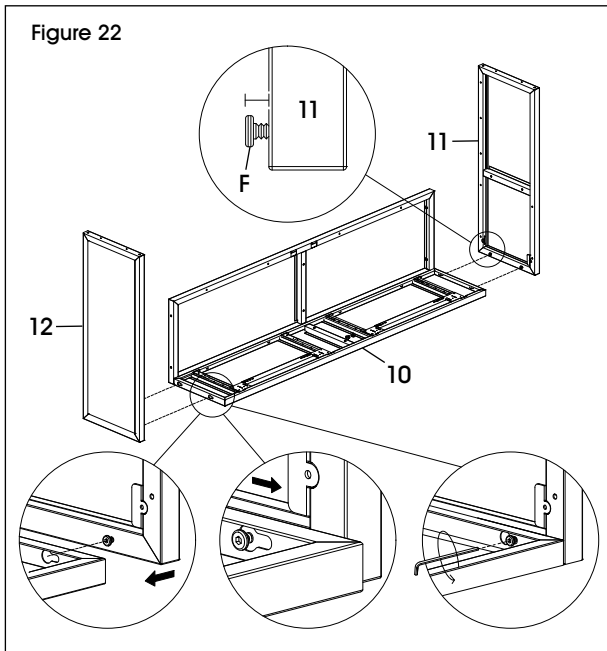

3. Insert two M6 x 45 mm bolts (B) to attach left side panel (11) to back panel (13). Tighten to secure. Repeat for right side panel (12). Fully tighten four M6 x 15 mm bolts from step 1 in top panel (10). (See Figure 23)

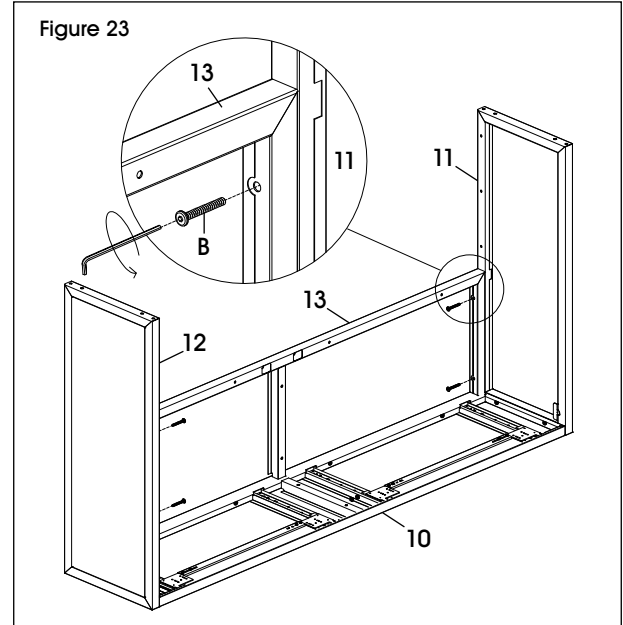

4. Place outer divider panel (14) in center of hutch and align with holes in top panel (10) and back panel (13). Use four M6 x 15 mm bolts (F) to secure. (See Figure 24)

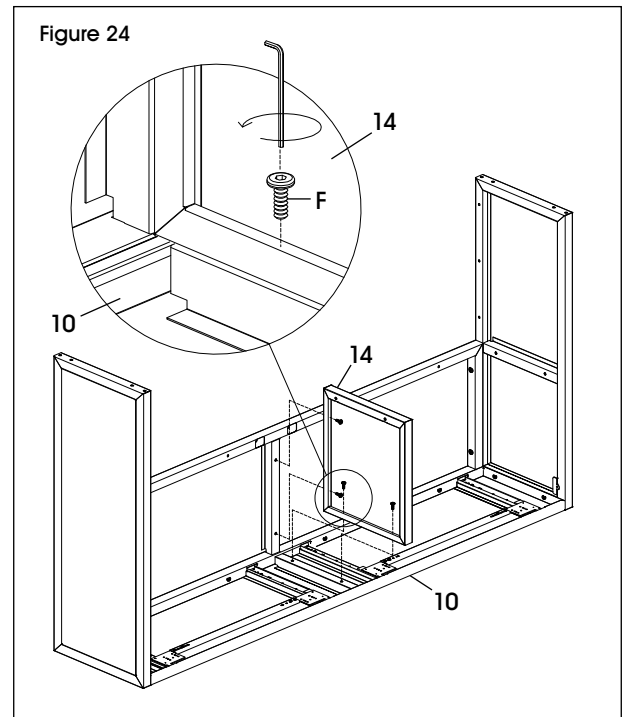

HUTCH INSTRUCTIONS CONTINUED

- Place inner divider panel (15) inside outer divider panel (14). Gently tap with rubber mallet to secure. Ensure edges of divider panels are flush with each other. (See Figure 25)

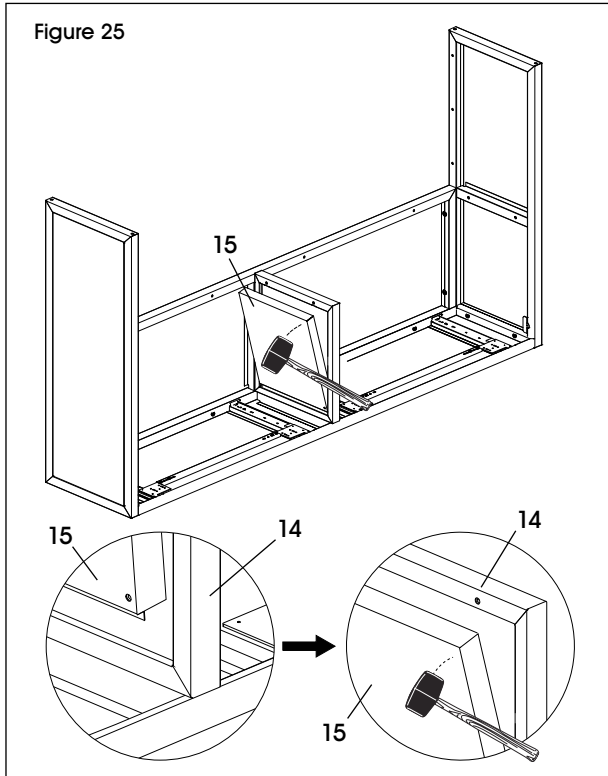

- Align bottom panels (16) with holes in side panels, back panel (13) and outer divider panel (14). (See Figure 26)

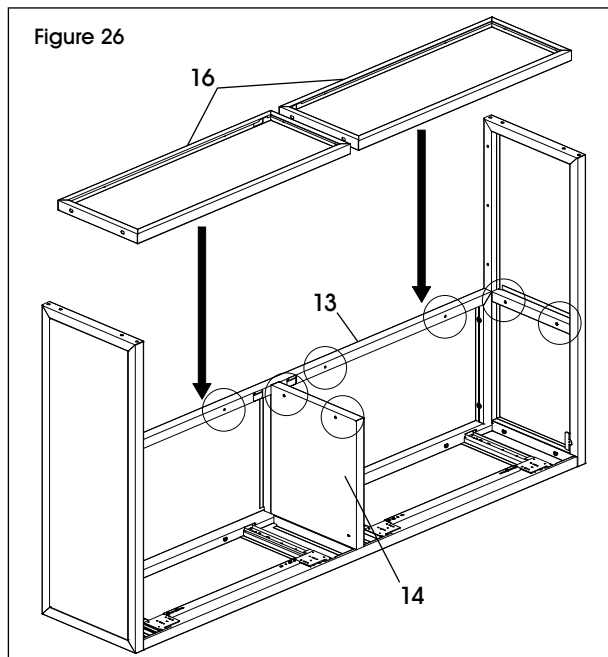

- Secure bottom panels (16) using 12 M6 x 15 mm bolts (F). (See Figure 27)

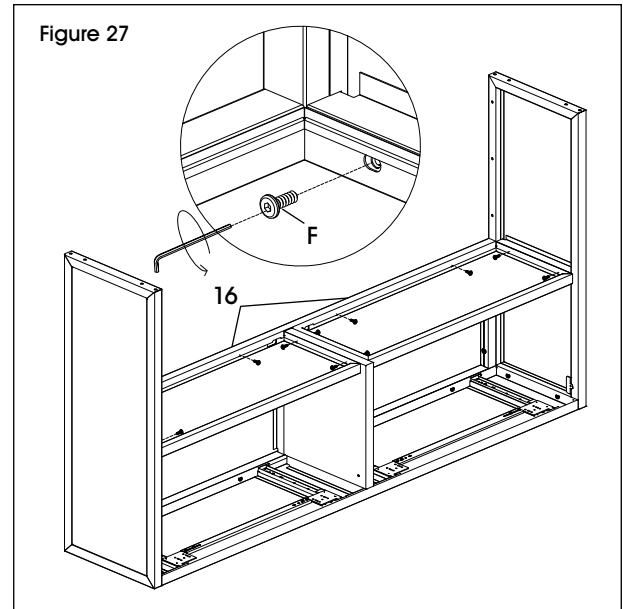

- Attach door wheels (P) to inside of the hutch using four M6 x 14 mm door bolts (Q). (See Figure 28)

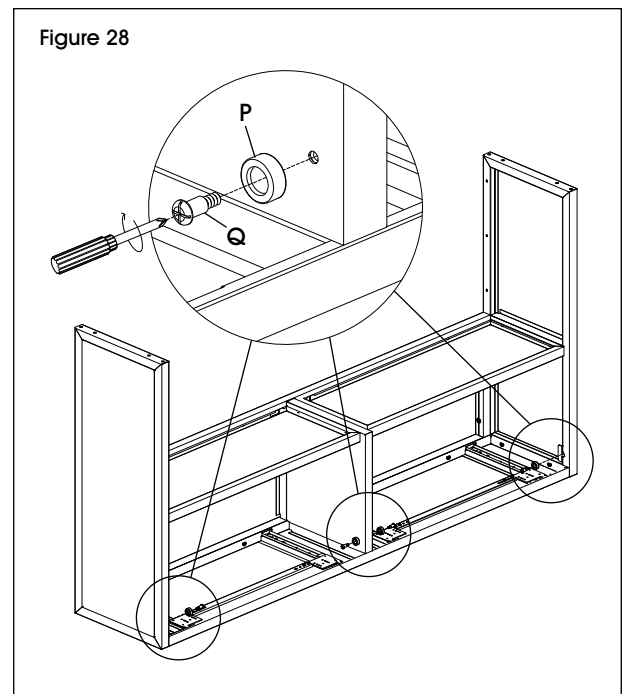

HUTCH INSTRUCTIONS CONTINUED

9. Attach hinges (M) to doors (17) using eight ST 3.5 x 14 mm hinge screws (N). (See Figure 29)

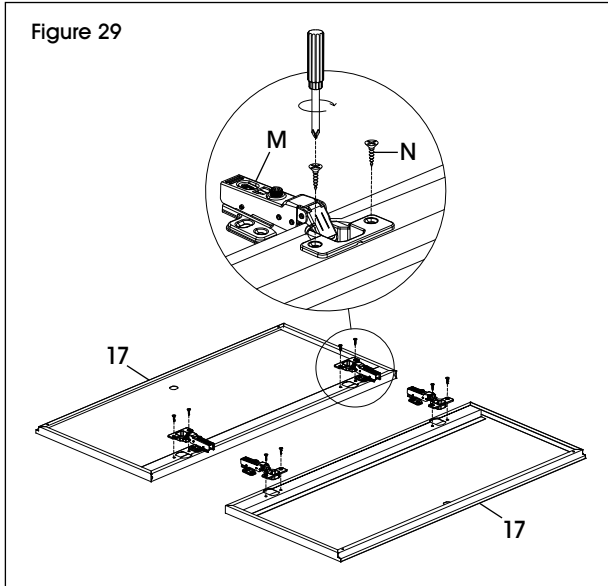

10. Remove lock plate and hex nut from cylinder (U). Insert the cylinder through the hole in door and tighten hex nut around the cylinder (U). Align the lock plate on the end of the cylinder and secure using screw (U). Repeat for remaining door. (See Figure 30)



IMPORTANT! Ensure lock plates are installed facing down in the "locked" position and facing up in the "unlocked" position.

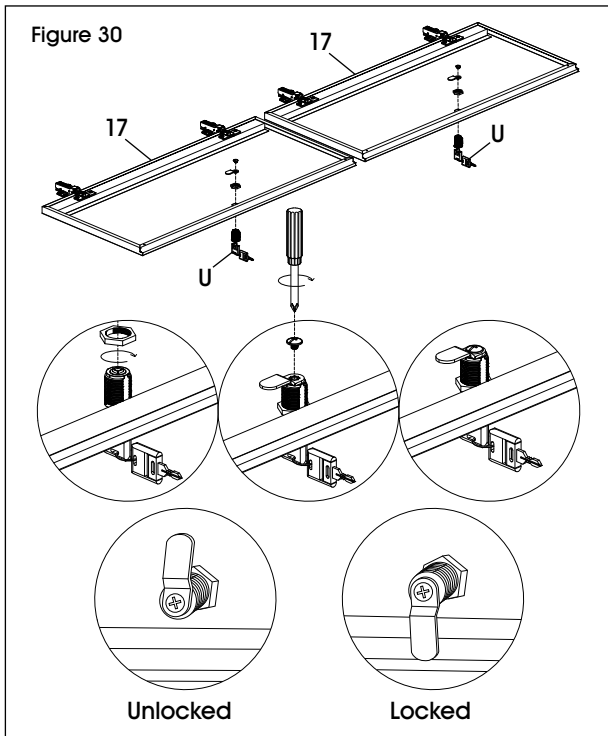

11. Align hinge (M) with holes in top panel (10). Use two M4 x 10 mm hinge bolts (O) to secure. Repeat for remaining three hinges. (See Figure 31)

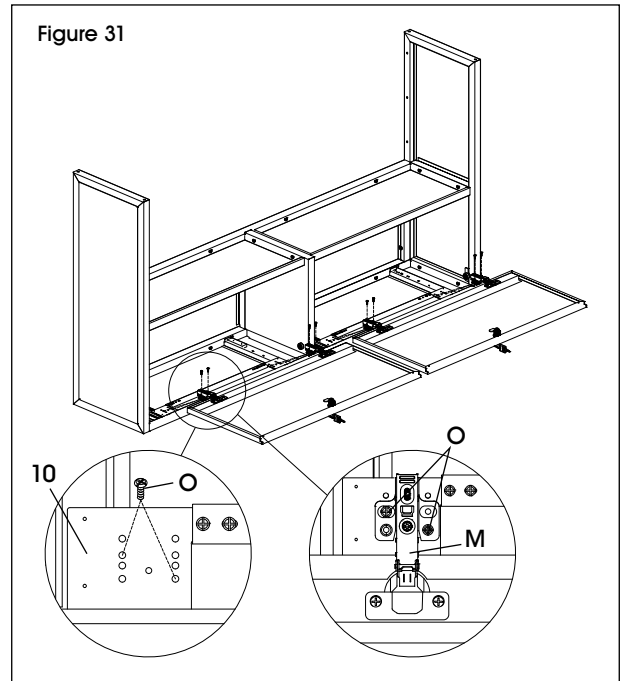

12. Adjust hinges to align the doors correctly. (See Figure 32)

- **Door angle:** Loosen hinge side screws, slide door left or right, then tighten screw to secure.
- **Door depth:** Loosen rear screw in hinge, slide door forward or backward, then tighten screw to secure.
- **Door height:** Tighten center screw to lower, or loosen center screw to raise.

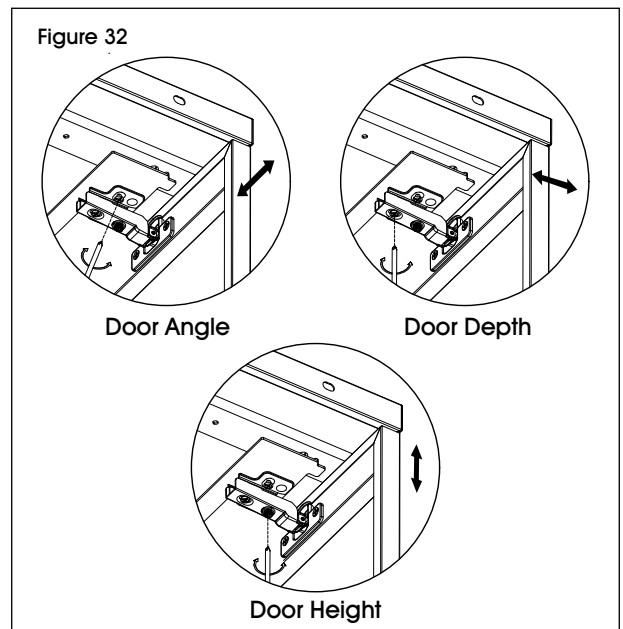

HUTCH INSTRUCTIONS CONTINUED



If attaching Uline model # H-10813 Tackboard, proceed to step 13. If not, continue to step 14.

13. Align tackboard (18) with holes in side panels. Use six M6 x 45 mm bolts (B) to secure. (See Figure 33)



NOTE: If necessary, tap tackboard with rubber mallet to position between side panels.

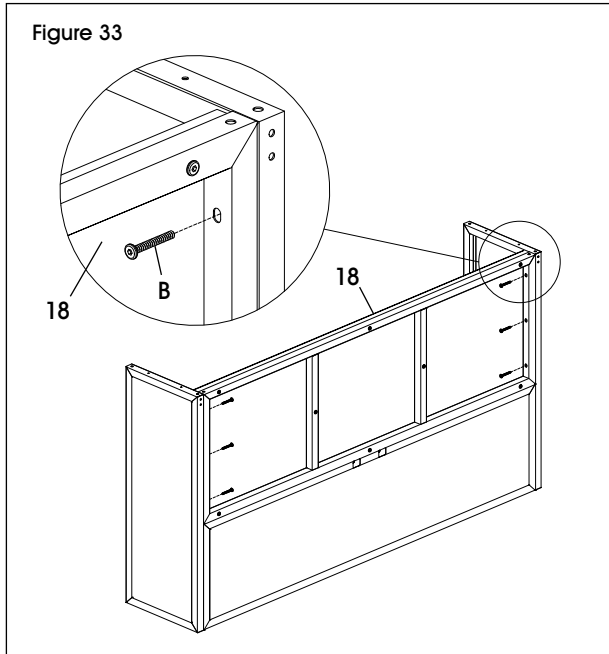

14. With second person, set hutch upright. Carefully place hutch onto desktop (1), flush with rear part of credenza. Attach hutch brackets (R) to credenza side panels and hutch side panels with eight M6 x 15 mm bolts (F). (See Figure 34)

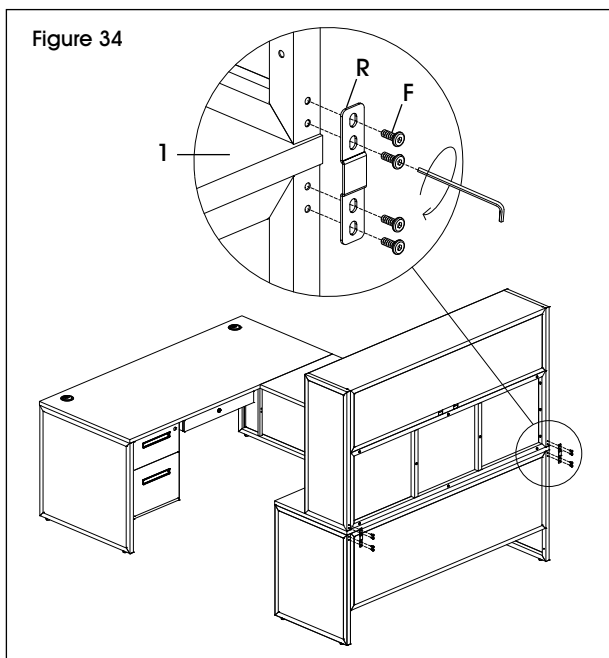

15. Secure hutch using four ST4 x 18 mm screws (S) through holes in hutch side panels and into desktop. Tighten with Phillips screwdriver. (See Figure 35)

Figure 35

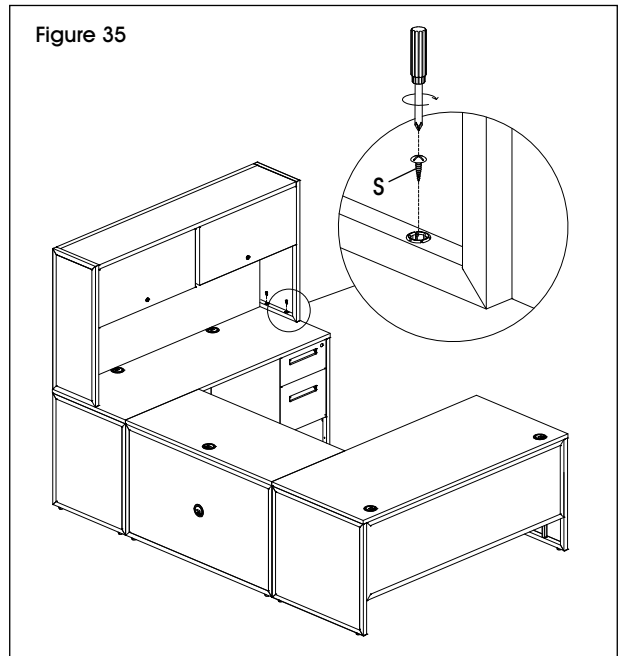

16. Insert plastic caps (T) into screw holes on inside of hutch side panels. Assembly is complete. (See Figure 36)



NOTE: If attaching light, proceed to next page. If not, assembly is complete.

Figure 36

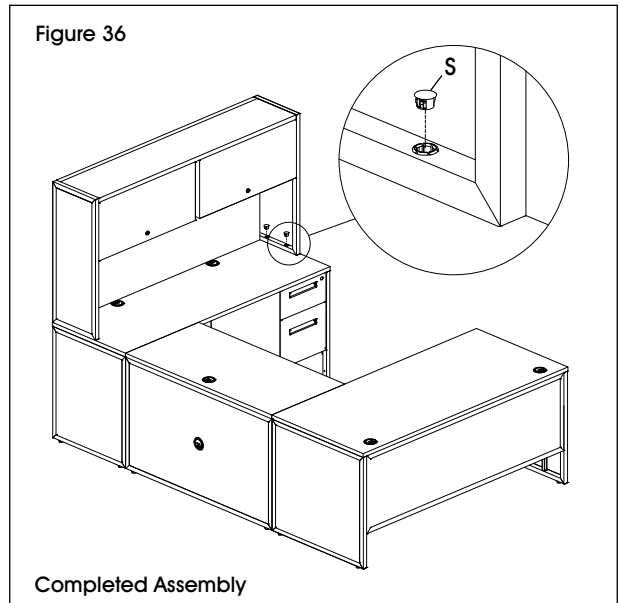

Completed Assembly

HUTCH INSTRUCTIONS CONTINUED

LIGHT INSTALLATION

Magnetic LED Light (Uline model # H-7162) can be attached underneath each overhead cabinet using the integrated mounting magnets.

1. Align light under overhead cabinet and magnets will secure in place. (See Figure 37)

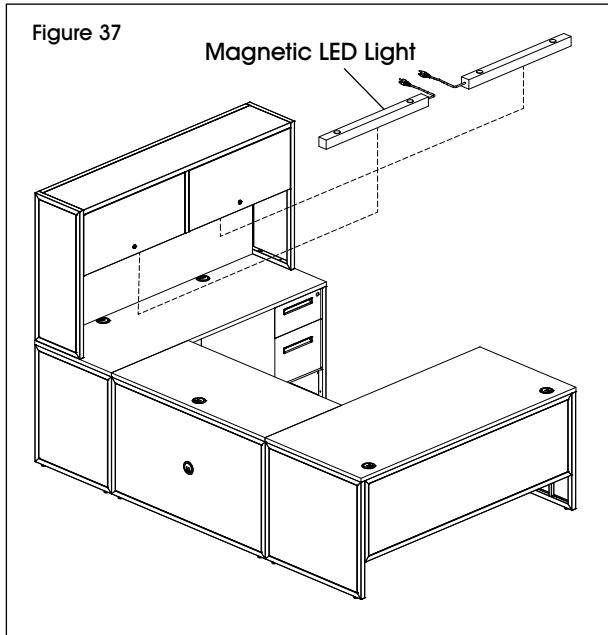

2. Feed plug ends through openings in back of hutch. (See Figure 38)

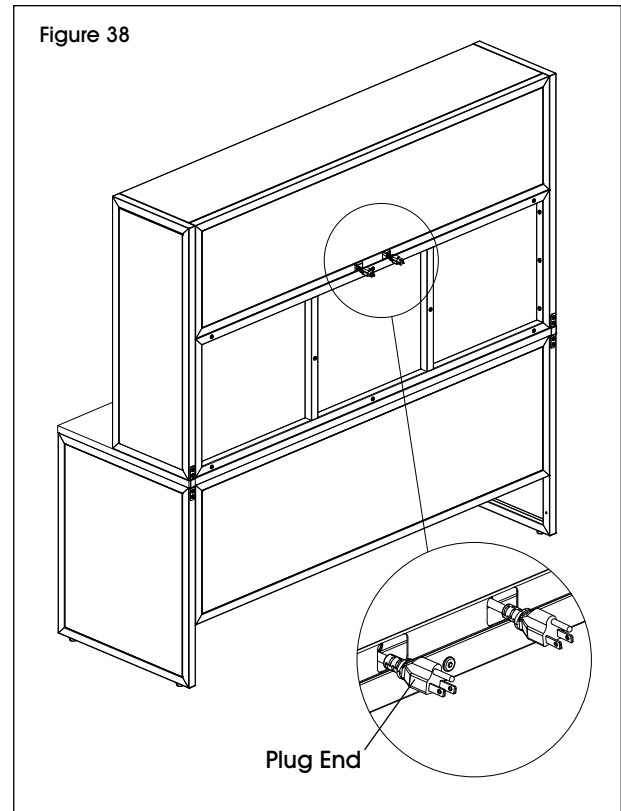

ULINE

1-800-295-5510
uline.com

LISTA DE CONTENIDO**ESCRITORIO**

Páginas 23-25

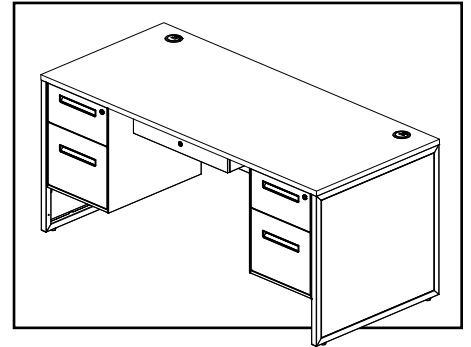
H-9730**ESCRITORIO EN L**

Páginas 26-30

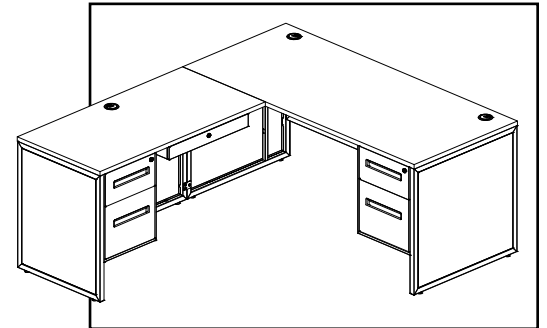
H-9731**ESCRITORIO EN U, ESCRITORIO EN U CON LIBRERO**

Páginas 31-42

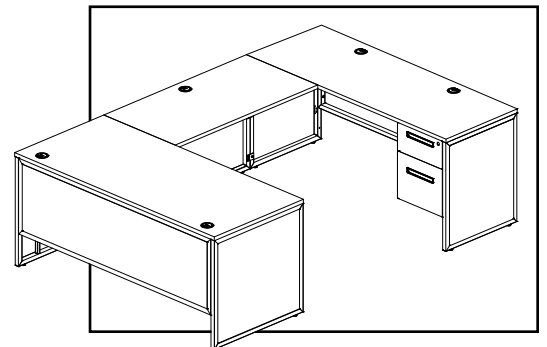
H-12038**H-12039**

ULINE H-9730

ESCRITORIO DE OFICINA

800-295-5510
uline.mx

HERRAMIENTAS NECESARIAS

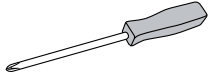

Desarmador de Cruz



Llave Allen (Incluida)



Taladro (Opcional)



Se recomienda Armar Entre Dos Personas

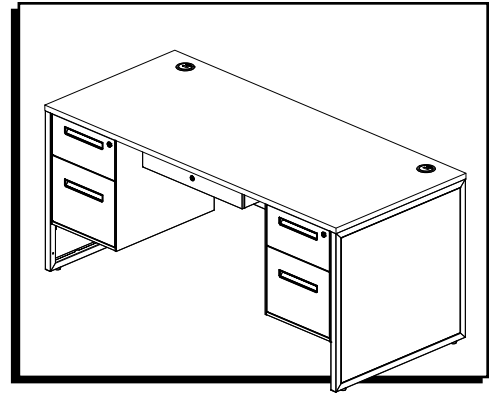

TORNILLERÍA

A



2 Tapas de Ojal

B

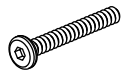

18 Pernos M6 x 45 mm

C

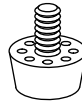

4 Tapas Niveladoras

D

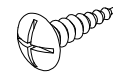

4 Tornillos para Madera ST5 x 16 mm

F



16 Pernos M6 x 15 mm

I

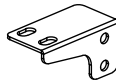

2 Soportes Izquierdos en L

J

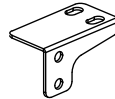

2 Soportes Derechos en L

K

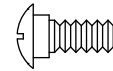

8 Tornillos de Hombro M6 x 14 mm

PARTES

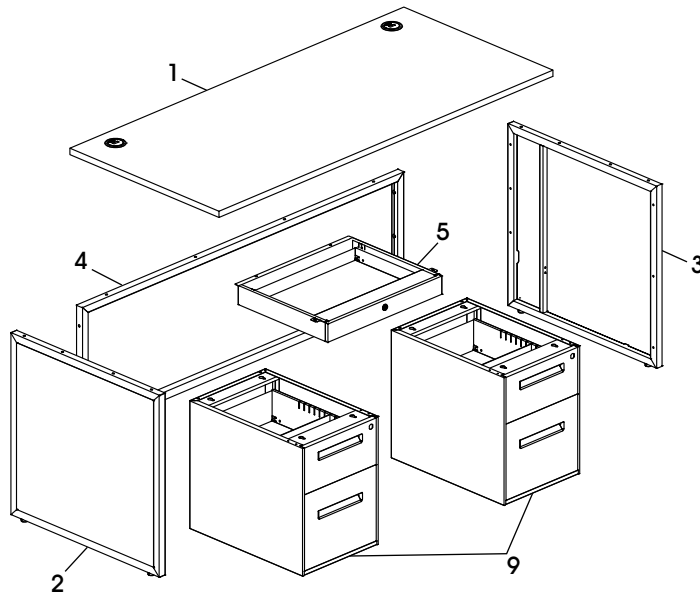

PARTES DEL ESCRITORIO

#	DESCRIPCIÓN	CANT.
1	Cubierta	1
2	Panel Lateral Izquierdo	1
3	Panel Lateral Derecho	1
4	Recato	1
5	Cajón Central	1
9	Archivero de Pedestal	2

INSTRUCCIONES DEL ESCRITORIO



¡IMPORTANTE! Ensamble sobre una superficie lisa que no deje marcas para evitar rayones.

NOTA: Revise que todas las partes estén incluidas.

NOTA: Utilice la llave Allen para apretar los pernos.

NOTA: Utilice un desarmador de cruz para apretar los tornillos.

NOTA: Tapas niveladoras y de ojal vienen preinstaladas.

1. Alinee el recato (4) con los orificios del panel lateral (2). Use tres pernos M6 x 45 mm (B) para fijarlos. Repita la operación con el panel lateral que falta. (Vea Diagrama 1)

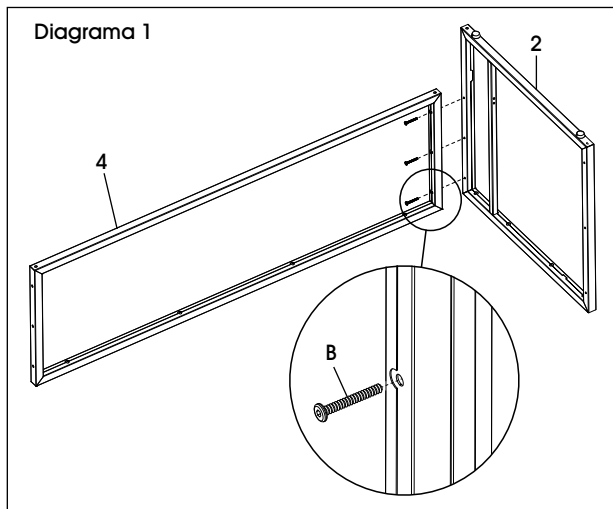

2. Coloque la cubierta del escritorio (1) boca abajo en una superficie que no deje marcas con los orificios hacia arriba. Con ayuda de otra persona, voltee el escritorio ensamblado. Use 12 pernos M6 x 45 mm (B) para fijar el escritorio a la cubierta. (Vea Diagrama 2)

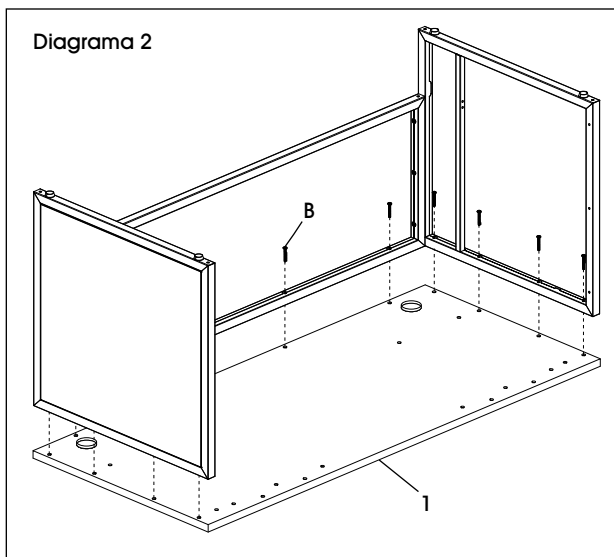

3. Inserte cuatro tornillos de hombro M6 x 14 mm (K) en la cubierta del escritorio. (Vea Diagrama 3)



NOTA: Los tornillos de hombro no quedarán a ras con la cubierta del escritorio. Los tornillos sobresalen un poco de la cubierta para conectarlos con el archivero de pedestal.

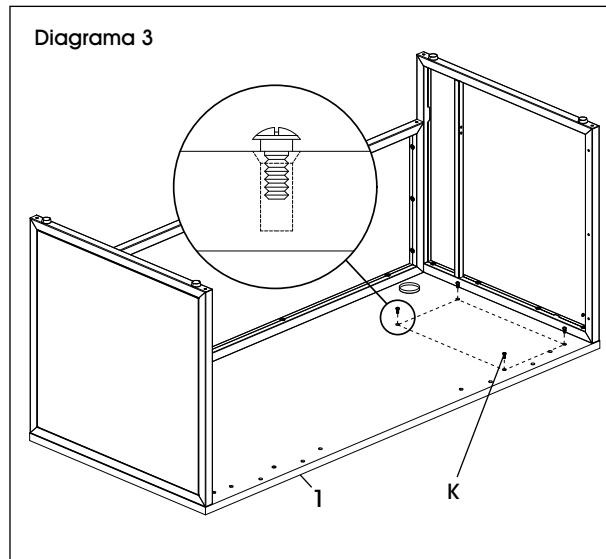

4. Con la ayuda de otra persona, voltee el archivero de pedestal (9). Baje el archivero de pedestal con cuidado y alinee las pestañas con ranura tipo llave del archivero con los tornillos de hombro (K) en la cubierta (1). (Vea Diagrama 4)



NOTA: El archivero de pedestal debe descansar sobre la cubierta y colgar un poco sobre el borde frontal.

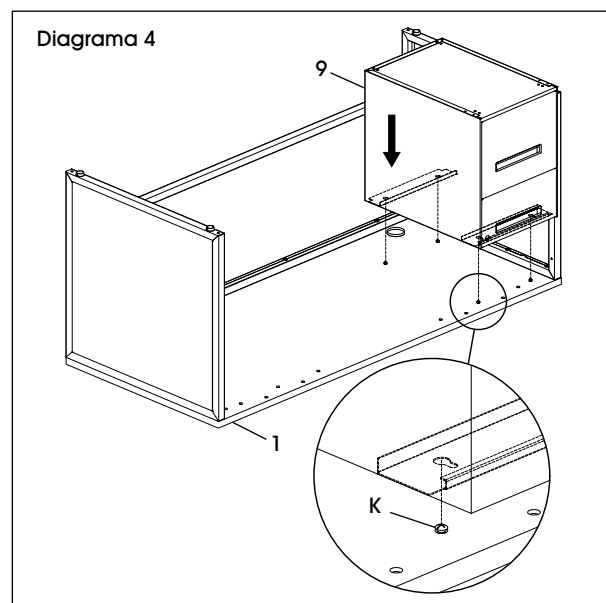

CONTINUACIÓN DE LAS INSTRUCCIONES DEL ESCRITORIO

5. Empuje el archivero de pedestal (9) hacia el recato (4) para enganchar las pestañas con ranura tipo llave en los tornillos de hombro (K). (Vea Diagrama 5)

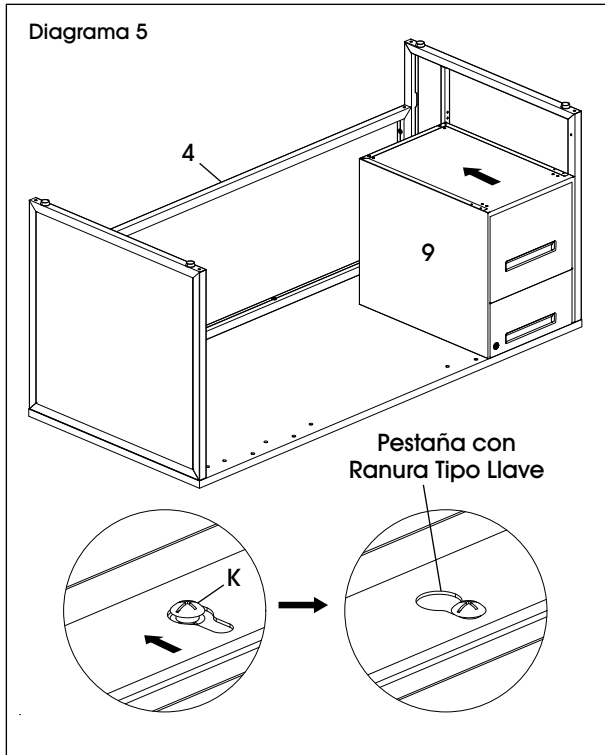

6. Fije la parte posterior del archivero de pedestal (9) al panel lateral con el Soporte en L izquierdo (I) y cuatro pernos M6 x 15 mm (F). Repita la operación en la parte frontal del archivero de pedestal con el Soporte en L derecho (J) y cuatro pernos M6 x 15 mm. (Vea Diagrama 6)

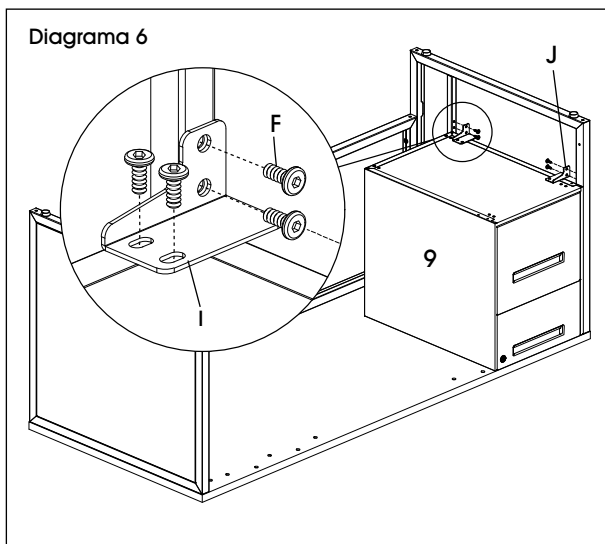

7. Repita los pasos 4-7 para instalar el archivero de pedestal restante en el otro lado.

8. Coloque el cajón central (5) al revés en la ubicación deseada del escritorio. Use cuatro tornillos autoperforantes para madera ST 5 x 16 mm (D) para fijarlo. (Vea Diagrama 7)

- NOTA: Los orificios prerroscados de la cubierta no se usan para conectar los cajones.
- NOTA: Los orificios del cajón se pueden hacer con taladro (opcional).
- NOTA: Se recomienda que el cajón esté a ras con el borde frontal de la cubierta del escritorio.

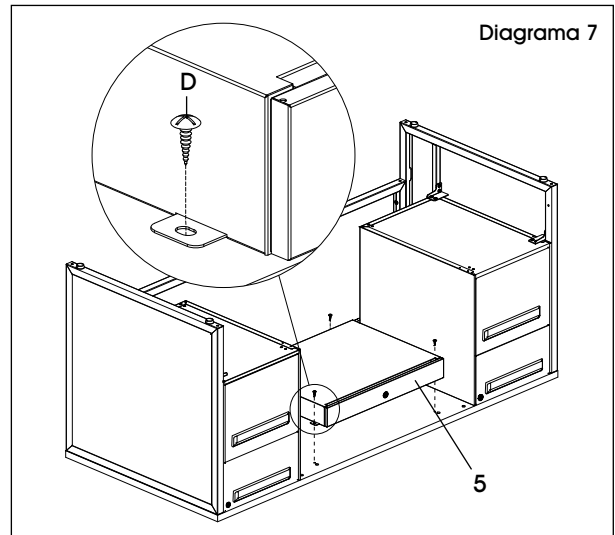

9. Con ayuda de otra persona, enderece el escritorio. Ajuste las patas niveladoras para compensar los pisos desnivelados. El ensamble ya está terminado. (Vea Diagrama 8)

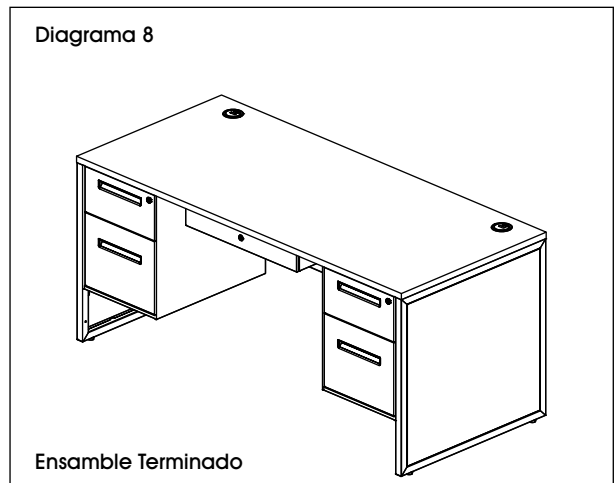

ULINE

800-295-5510
uline.mx

ULINE H-9731

800-295-5510

uline.mx

ESCRITORIO EN L DE OFICINA

HERRAMIENTAS NECESARIAS

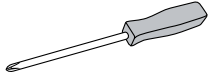

Desarmador de Cruz



Llave Allen (Incluida)



Taladro (Opcional)



Se recomienda Armar Entre Dos Personas

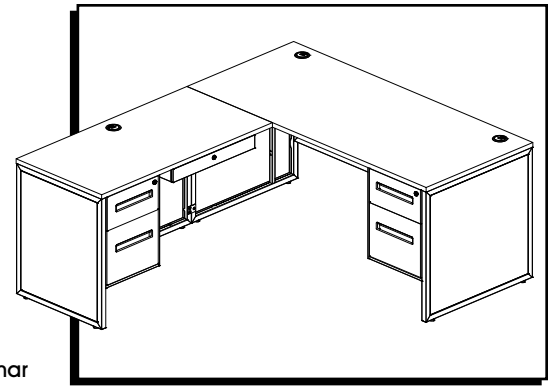

TORNILLERÍA

A



4 Tapas de Ojal

B

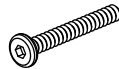

28 Pernos M6 x 45 mm

C



8 Tapas Niveladoras

D

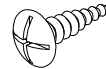

4 Tornillos para Madera ST 5 x 16 mm

F

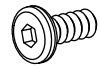

33 Pernos M6 x 15 mm

G

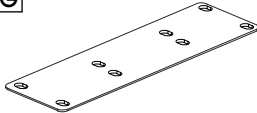

1 Placa Conectora

H

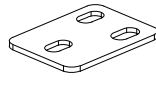

3 Soportes en L

I

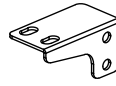

2 Soportes Izquierdos en L

J

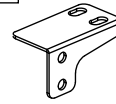

2 Soportes Derechos en L

K

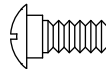

8 Tornillos de Hombro M6 x 14 mm

PARTES

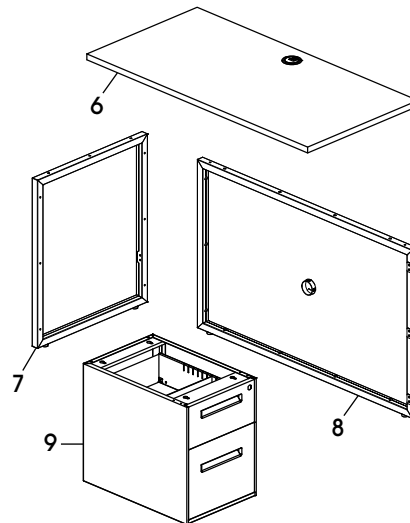
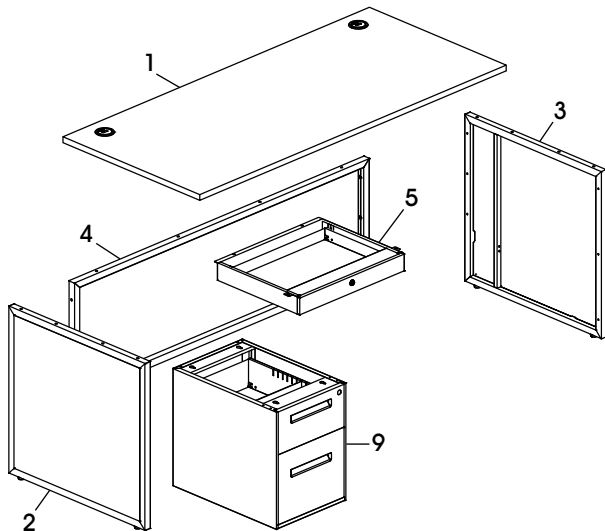

PARTES DEL ESCRITORIO EN L

#	DESCRIPCIÓN	CANT.
1	Cubierta	1
2	Panel Lateral Izquierdo	1
3	Panel Lateral Derecho	1
4	Recato	1
5	Cajón Central	1
9	Archivero de Pedestal	1

PARTES DEL RETORNO

#	DESCRIPCIÓN	CANT.
6	Cubierta para Retorno de Escritorio	1
7	Panel Lateral del Retorno	1
8	Recato del Retorno	1
9	Archivero de Pedestal	1

INSTRUCCIONES DEL ESCRITORIO EN L



¡IMPORTANTE! Ensamble sobre una superficie lisa que no deje marcas para evitar rayones.

NOTA: Revise que todas las partes estén incluidas.

NOTA: Utilice la llave Allen para apretar los pernos.

NOTA: Utilice un desarmador de cruz para apretar los tornillos.

NOTA: Tapas niveladoras y de ojal vienen preinstaladas.



ALTO: Determine si el escritorio L estará configurado para zurdos o diestros. Esto impactará el ensamble del retorno. Se muestra el ensamble de un escritorio en L para diestros en los siguientes diagramas.

3. Fije el archivero de pedestal al lado derecho de la cubierta del escritorio (1) cuando esté al revés. Inserte cuatro tornillos de hombro M6 x 14 mm (K) en la cubierta del escritorio y apriételos utilizando un desarmador de cruz. (Vea Diagrama 3)



NOTA: Los tornillos de hombro no quedarán a ras con la cubierta del escritorio. Los tornillos sobresalen un poco de la cubierta para conectarlos con el archivero de pedestal.

ENSAMBLE DEL ESCRITORIO

1. Alinee el recato (4) con los orificios del panel lateral (2). Use tres tornillos M6 x 45 mm (B) para asegurarlo. Repita la operación con el panel lateral opuesto. (Vea Diagrama 1)

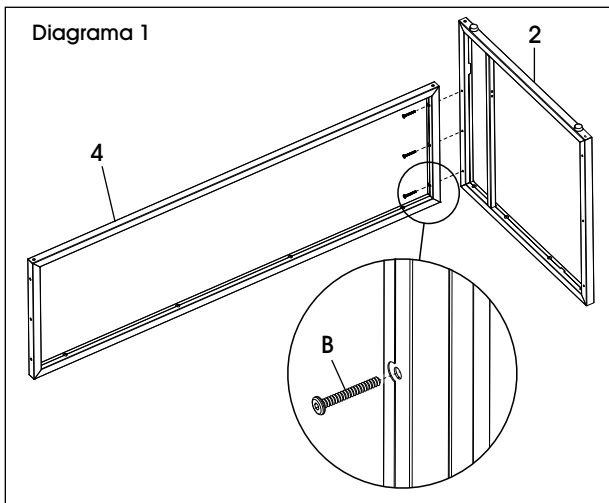

2. Coloque la cubierta del escritorio (1) boca abajo en una superficie que no deje marcas con los orificios hacia arriba. Con ayuda de otra persona, voltee el armazón ensamblado del escritorio. Use 12 pernos M6 x 45 mm (B) para fijar el armazón del escritorio a la cubierta. (Vea Diagrama 2)

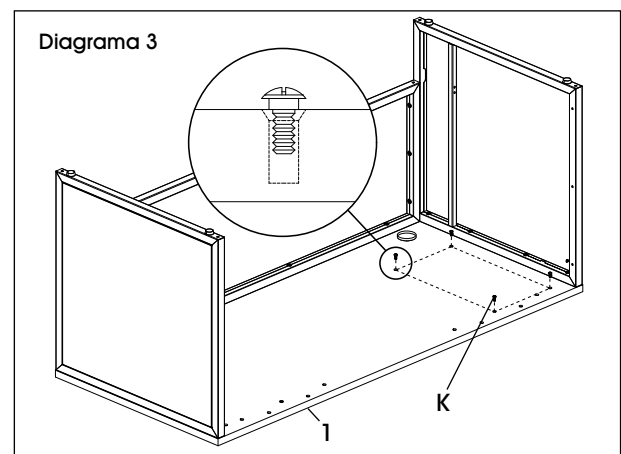
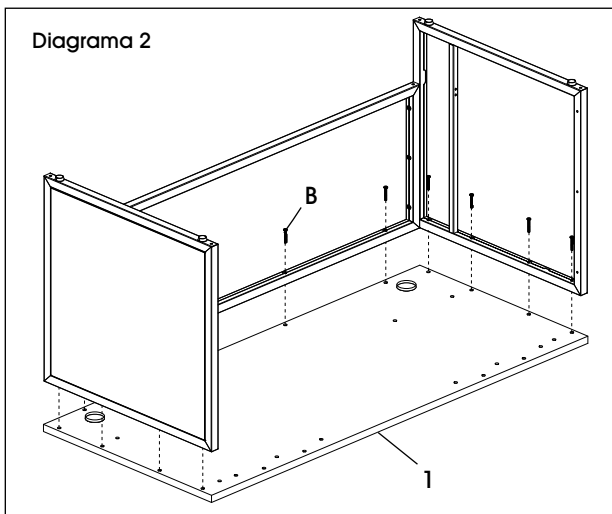

4. Con la ayuda de otra persona, voltee el archivero de pedestal (9) al revés. Baje el archivero de pedestal con cuidado y alinee las pestañas con ranura tipo llave del archivero con los tornillos de hombro (K) en la cubierta (1). (Vea Diagrama 4)



NOTA: El archivero de pedestal debe descansar sobre la cubierta y colgar un poco del borde frontal.

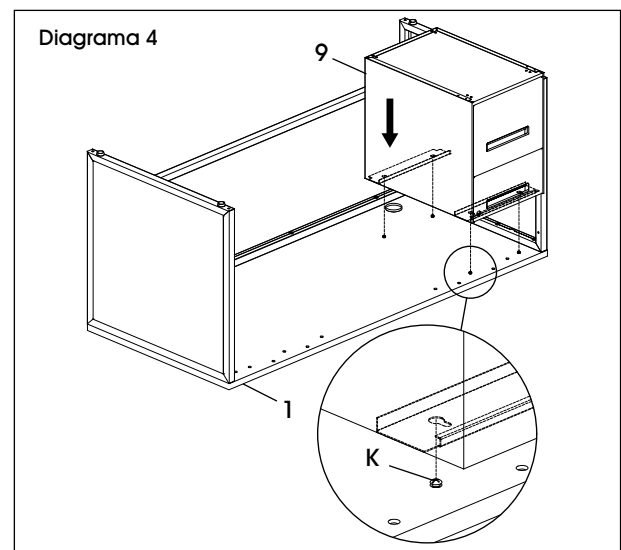

CONTINUACIÓN DE LAS INSTRUCCIONES DEL ESCRITORIO EN L

5. Fije la parte posterior del archivero de pedestal (9) al panel lateral con el Soporte en L izquierdo (I) y cuatro pernos M6 x 15 mm (F). Repita la operación en la parte frontal del archivero de pedestal con el Soporte en L derecho (J) y cuatro pernos M6 x 15 mm. (Vea Diagrama 5)

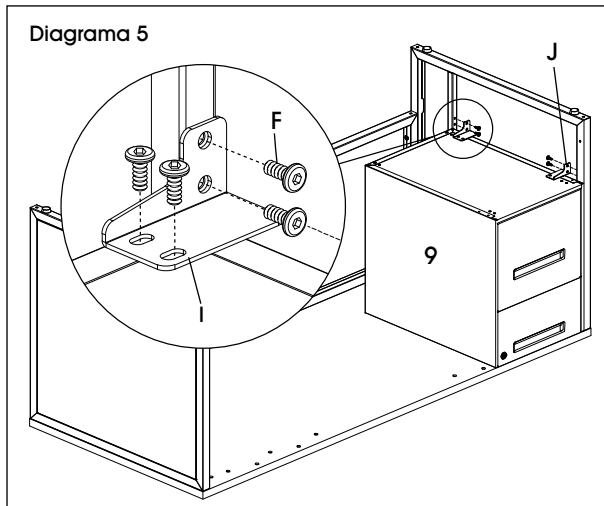

6. Fije la placa de unión (G) a la cubierta del escritorio (1) con cuatro pernos M6 x 15 mm (F). (Vea Diagrama 6)

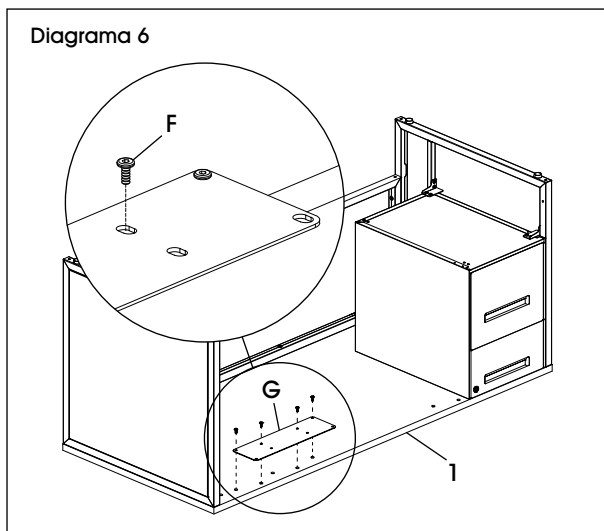

7. Con ayuda de otra persona, enderece el escritorio.

 **NOTA:** Antes de proceder, asegúrese de que el escritorio se encuentre en la ubicación deseada. Es difícil de mover cuando está completamente ensamblado.

ENSAMBLE DEL RETORNO

1. Alinee el recato del retorno (8) con los orificios del panel lateral del retorno (7). Utilice tres pernos M6 x 45 mm (B) para asegurarlo. (Vea Diagrama 7)

 **NOTA:** Para la configuración del Escritorio en L para zurdos, debe fijar el panel lateral del retorno al lado opuesto del recato del retorno.

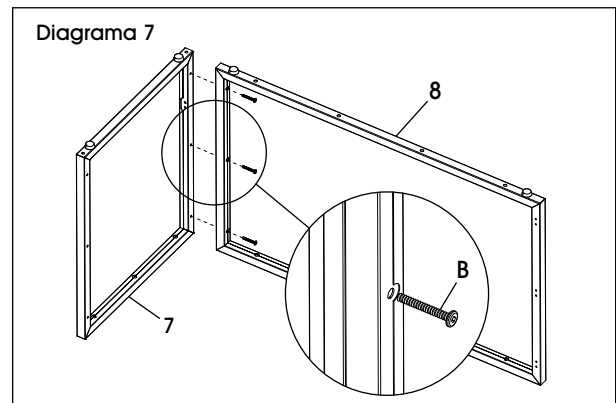

2. Coloque la cubierta del escritorio (6) boca abajo con los orificios hacia arriba. Con ayuda de otra persona, voltee el armazón ensamblado del escritorio en L al revés. Use siete pernos M6 x 45 mm (B) para asegurar el armazón del escritorio a la cubierta. (Vea Diagrama 8)

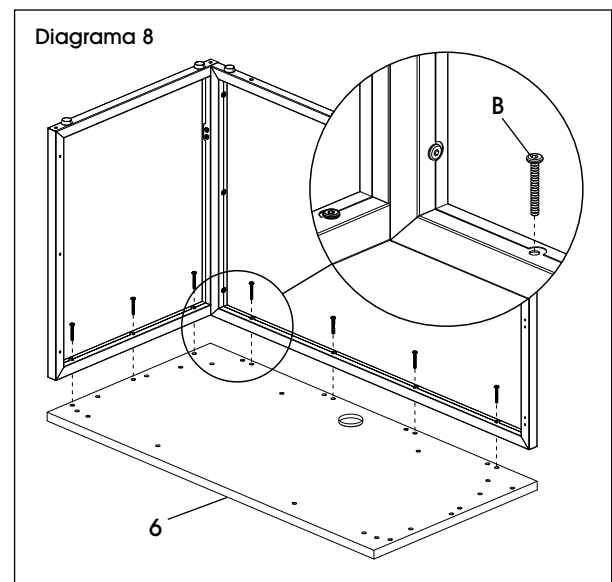

CONTINUACIÓN DE LAS INSTRUCCIONES DEL ESCRITORIO EN L

3. Instale cuatro tornillos de hombro M6 x 14 mm para archivero de pedestal (K) en la cubierta del escritorio (6). (Vea Diagrama 9)



NOTA: Los tornillos de hombro (K) no quedarán a ras con la cubierta del escritorio (6). Los tornillos sobresalen un poco de la cubierta para la conexión al archivero de pedestal.

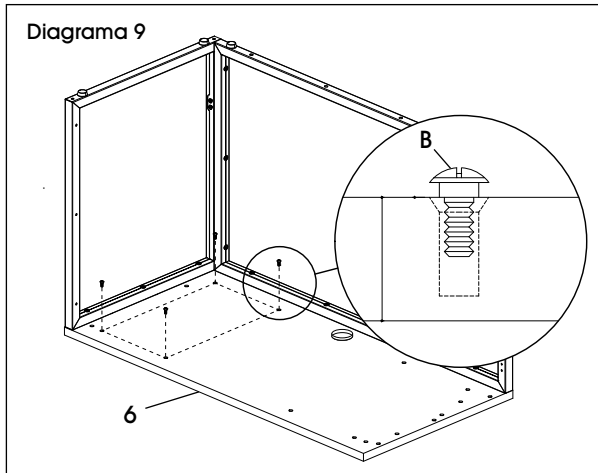

4. Con la ayuda de otra persona, voltee el archivero de pedestal (9). Baje el archivero de pedestal con cuidado y alinee las pestañas con ranura tipo llave del archivero con los tornillos de hombro (K) en la cubierta del retorno (6). (Vea Diagrama 10)

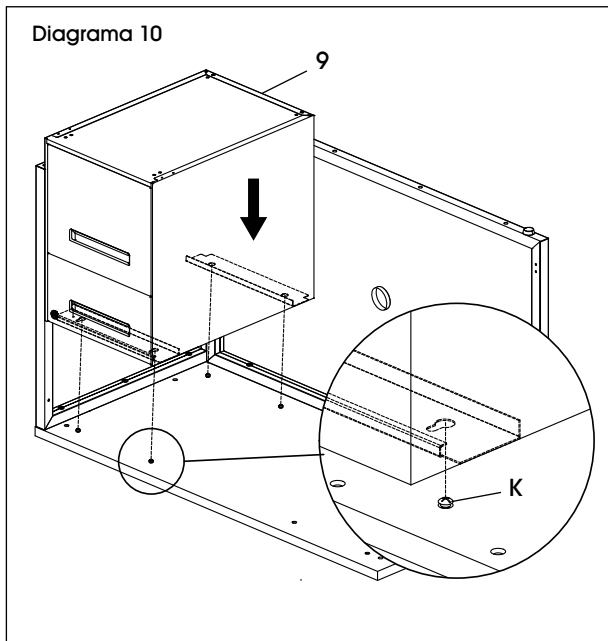

5. Empuje el archivero de pedestal (9) hacia el recato del retorno (8) para enganchar las pestañas con ranura tipo llave en los tornillos de hombro (K). (Vea Diagrama 11)

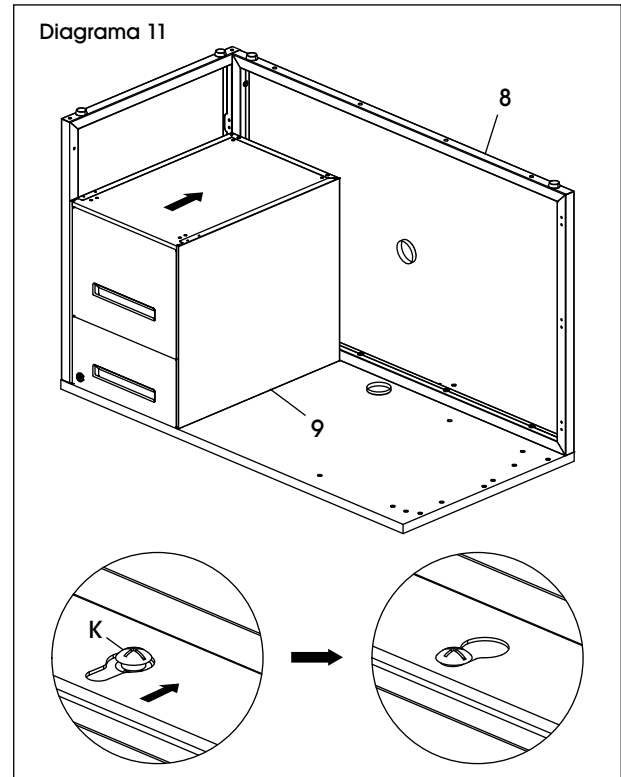

6. Fije la parte posterior del archivero de pedestal (9) al panel lateral del retorno con el Soporte en L derecho (J) y cuatro pernos M6 x 15 mm (F). Repita la operación en la parte frontal del archivero de pedestal con el Soporte en L izquierdo (J) y cuatro pernos M6 x 15 mm. (Vea Diagrama 12)

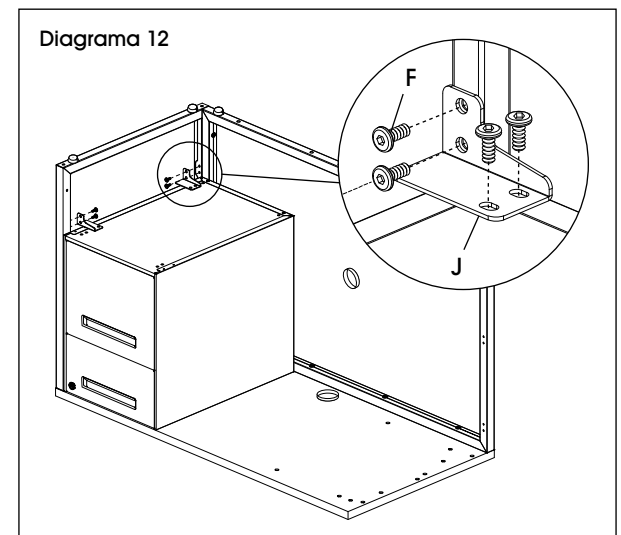

ENSAMBLE FINAL

1. Con ayuda de otra persona, enderece el retorno del Escritorio en L y colóquelo a lado del escritorio ensamblado. Fije la placa de unión (G) a la cubierta del escritorio de retorno (6) con cuatro pernos M6 x 15 mm (F). (Vea Diagrama 13)

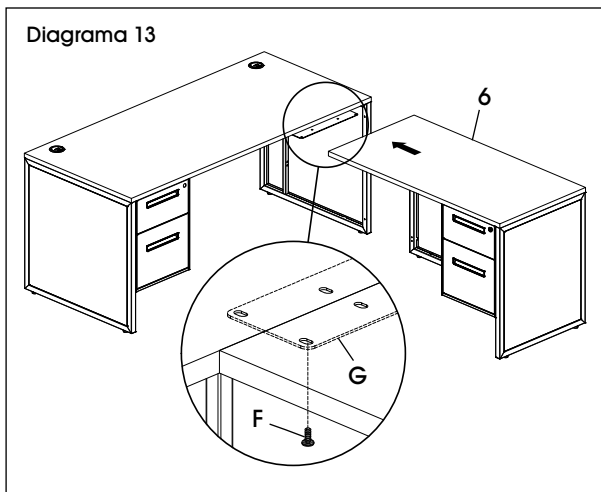

2. Fije un Soporte en I (H) con tres pernos M6 x 15 mm (F) para asegurar el recato del retorno al panel lateral adyacente. Repita la operación con los dos soportes en I restantes. (Vea Diagrama 14)

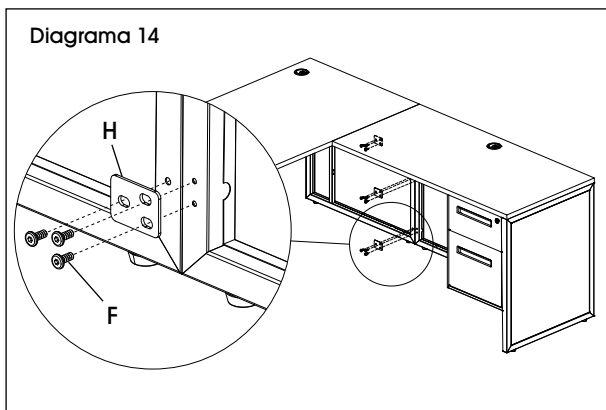

3. Con la ayuda de otra persona, sostenga el cajón central (5) en la ubicación deseada de la cubierta del escritorio o del retorno. Utilice cuatro tornillos auto perforantes para madera ST 5 x 16 mm (D) para fijarlo. (Vea Diagrama 15)

NOTA: Los orificios prerroscados de la cubierta no se utilizan para conectar los cajones.

NOTA: Los orificios para el cajón se pueden hacer con taladro. (opcional)

NOTA: Se recomienda que el cajón esté a ras con el borde frontal de la cubierta del escritorio.

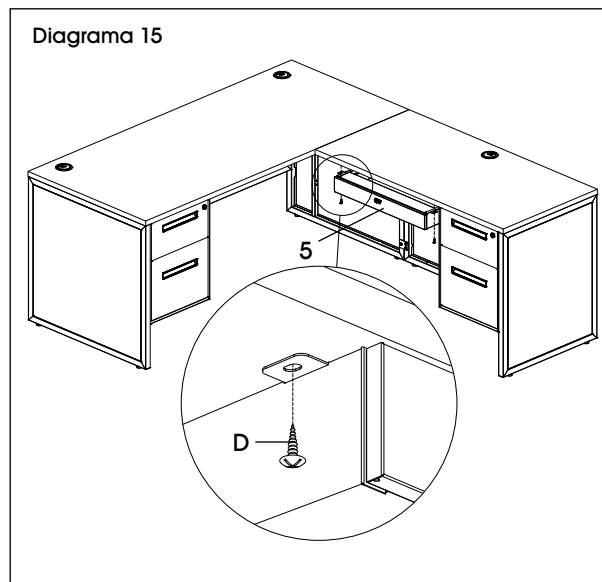

4. Ajuste las patas niveladoras para compensar los pisos desnivelados. El ensamble ya está terminado. (Vea Diagrama 16)

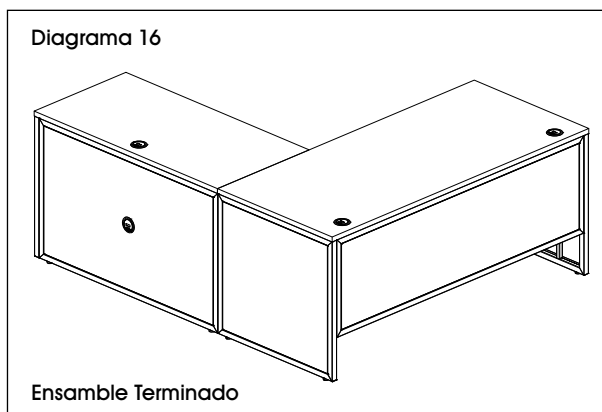

ULINE

800-295-5510
uline.mx

ULINE H-12038, H-12039

ESCRITORIO EN U

800-295-5510
uline.mx

HERRAMIENTAS NECESARIAS



Se Recomendamos Armar
Entre Dos Personas

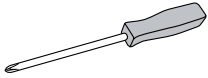
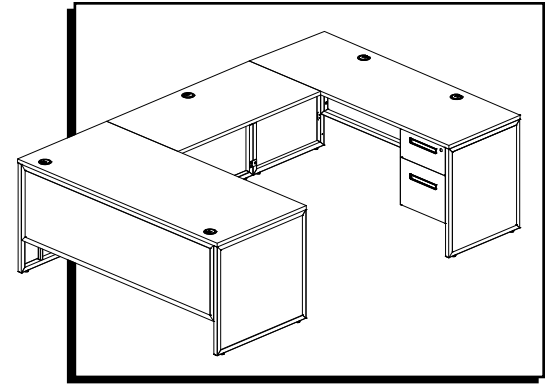

Desarmador
de Cruz



Llave Allen
(Incluida)



Taladro
(Opcional)



Mazo de Caucho

TORNILLERÍA

A



6 Tapas de Ojal

B

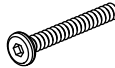

36 Pernos
M6 x 45 mm

C



10 Tapas Niveladoras

D

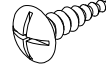

4 Tornillos para Madera
ST 5 x 16 mm

F



50 Pernos
M6 x 15 mm

G

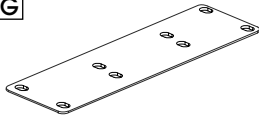

2 Placas Conectoras

H

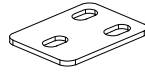

6 Soportes en I

I

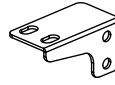

2 Soportes
Izquierdos en L

J

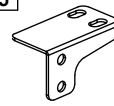

2 Soportes
Derechos en L

K

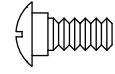

8 Tornillos de Hombro
M6 x 14 mm

PARTES

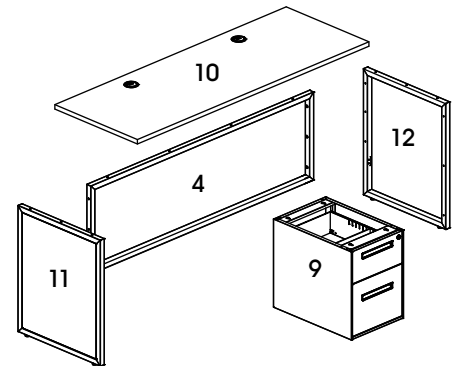
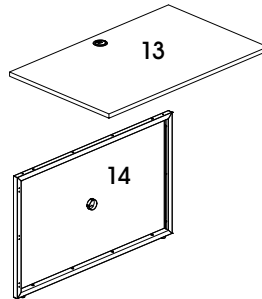
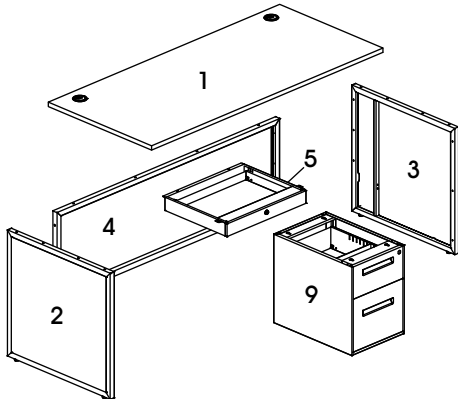

PARTES DEL ESCRITORIO

#	DESCRIPCIÓN	CANT.
1	Panel de Cubierta 66 x 30"	1
2	Panel Lateral Izquierdo de 30" de ancho	1
3	Panel Lateral Derecho de 30" de ancho	1
4	Recato	1
5	Cajón Central	1
9	Archivero de Pedestal	1

PARTES DEL PUENTE

#	DESCRIPCIÓN	CANT.
13	Panel de Cubierta del Puente	1
14	Recato del Puente	1

PARTES DE LA CREDENZA

#	DESCRIPCIÓN	CANT.
4	Recato	1
9	Archivero de Pedestal	1
10	Panel Superior de la Credenza - 66 x 24"	1
11	Panel Lateral Izquierdo de 24" de ancho	1
12	Panel Lateral Derecho de 24" de ancho	1

INSTRUCCIONES DEL ESCRITORIO EN U



¡IMPORTANTE! Ensamble sobre una superficie lisa que no deje marcas para evitar rayones.

NOTA: Revise que todas las partes estén incluidas.

NOTA: Utilice la llave Allen para apretar los pernos.

NOTA: Utilice un desarmador de cruz para apretar los tornillos.

NOTA: Tapas niveladoras y de ojal vienen preinstaladas.

ENSAMBLE DEL ESCRITORIO

1. Alinee el recato (4) con los orificios del panel lateral de 30" (2). Utilice tres pernos M6 x 45 mm (B) para fijarlo. Repita con el segundo panel lateral. (Vea Diagrama 1)

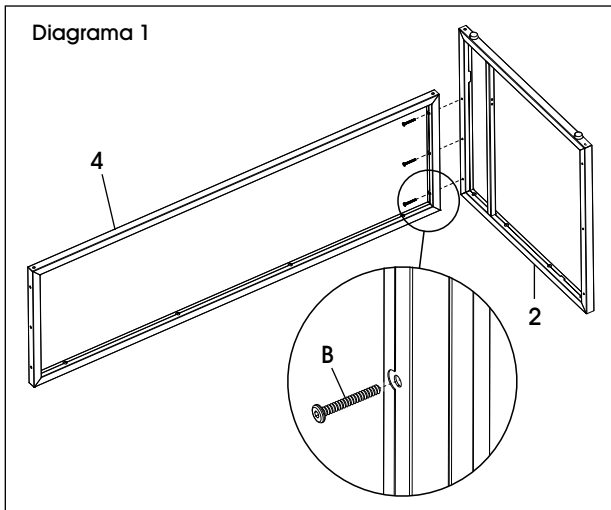

2. Coloque la cubierta de 66 x 30" (1) boca abajo con los orificios hacia arriba. Con ayuda de otra persona, voltee el armazón ensamblado del escritorio. Use 12 pernos M6 x 45 mm (B) para fijar el armazón del escritorio a la cubierta. (Vea Diagrama 2)

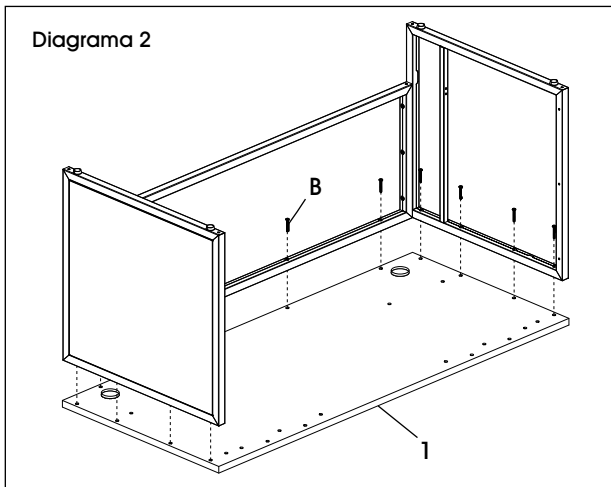

ALTO: Determine si el escritorio en U estará configurado para zurdos o diestros. Se muestra el ensamble de un escritorio en U para diestros en los siguientes diagramas.

3. Inserte cuatro tornillos de hombro M6 x 14 mm en la cubierta del escritorio (1) y apriételes utilizando un desarmador de cruz. (Vea Diagrama 3)



NOTA: Para la configuración del escritorio en L para zurdos, inserte los tornillos en el lado opuesto de la cubierta.



NOTA: Los tornillos de hombro no quedarán a ras con la cubierta del escritorio. Los tornillos sobresalen un poco de la cubierta para conectarlos con el archivero de pedestal.

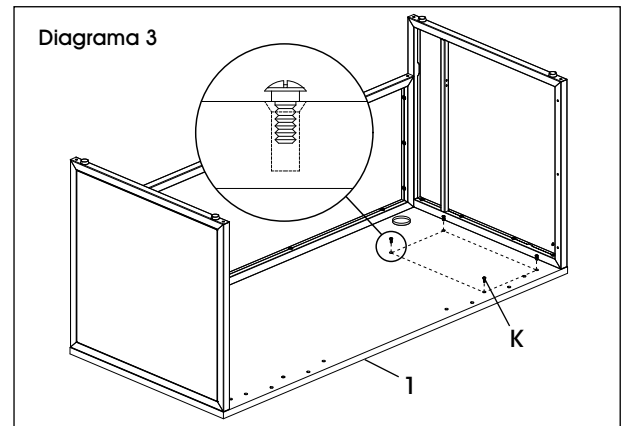

4. Con la ayuda de otra persona, voltee el archivero de pedestal (9) al revés. Baje el archivero de pedestal con cuidado y alinee las pestañas con ranura tipo llave del archivero con los tornillos de hombro (K) en la cubierta (1). (Vea Diagrama 4)



NOTA: El archivero de pedestal debe descansar sobre la cubierta y colgar un poco del borde frontal.

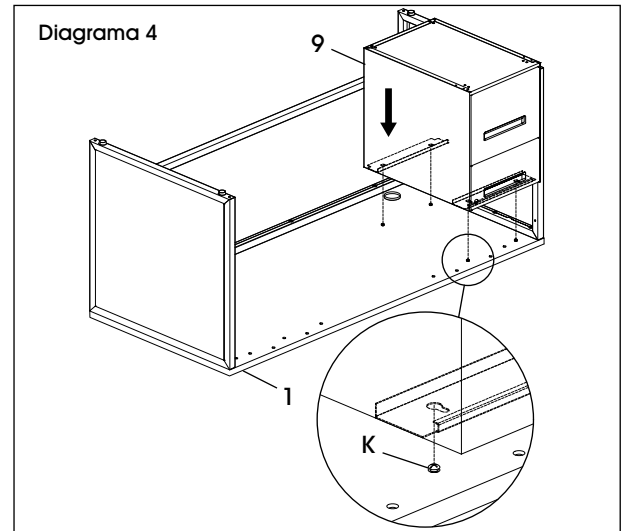

CONTINUACIÓN DE LAS INSTRUCCIONES DEL ESCRITORIO EN U

5. Empuje el archivero de pedestal (9) hacia el recato (4) para enganchar las pestañas con ranura tipo llave en los tornillos de hombro (K). (Vea Diagrama 5)

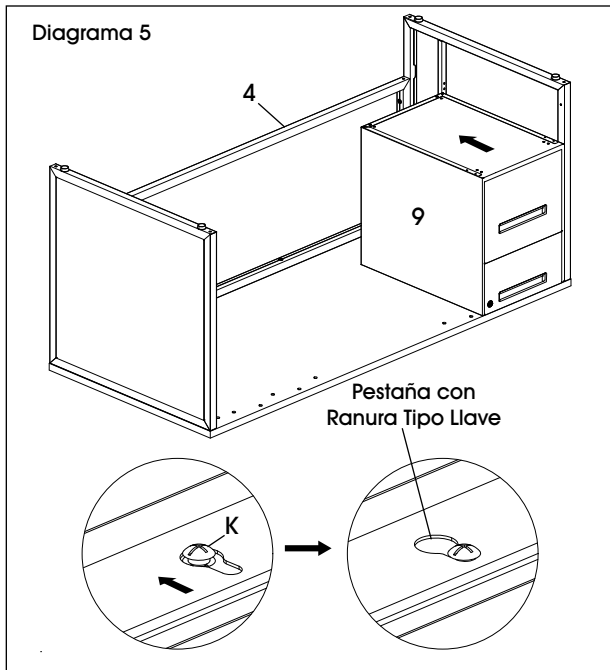

6. Fije la parte posterior del archivero de pedestal (9) al panel lateral con el Soporte en L izquierdo (1) y cuatro pernos M6 x 15 mm (F). Repita la operación en la parte frontal del archivero de pedestal con el Soporte en L derecho (J) y cuatro pernos M6 x 15 mm. (Vea Diagrama 6)

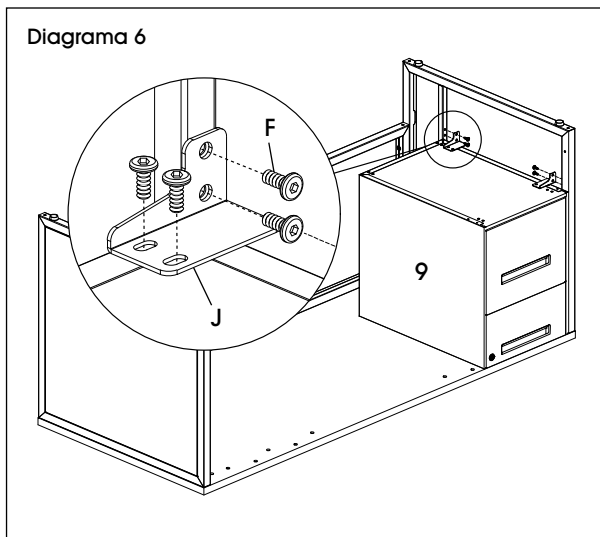

7. Coloque el cajón central (5) al revés en la ubicación deseada de la cubierta del escritorio. Utilice cuatro tornillos para madera ST 5 x 6 mm (D) para fijarlo. (Vea Diagrama 7)



NOTA: Los orificios prerroscaados de la cubierta no se utilizan para conectar los cajones.



NOTA: Los orificios del cajón se pueden hacer con taladro (opcional).



NOTA: Se recomienda que el cajón esté a ras con el borde frontal de la cubierta del escritorio.

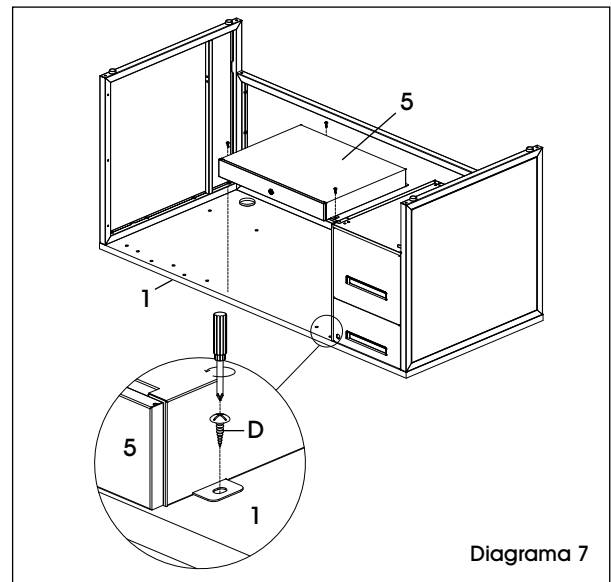

8. Fije la placa de unión (G) a la cubierta del escritorio (1) utilizando cuatro pernos M6 x 15 mm (F). (Vea Diagrama 8)

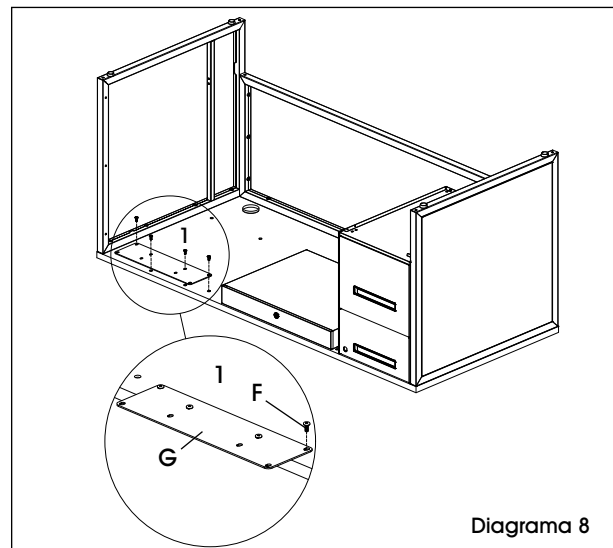

ENSAMBLE DEL PUENTE

Fije el recato del puente (14) al panel de cubierta del puente (13) utilizando cuatro pernos M6 x 45 mm (B). (Vea Diagrama 9)

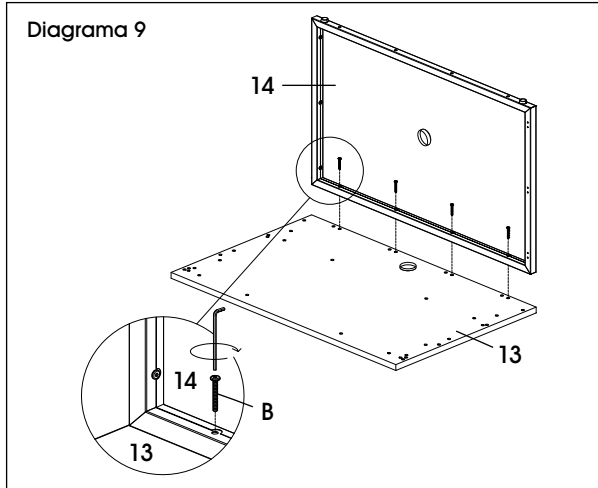

ENSAMBLE DE LA CREDENZA

1. Alinee el recato (4) con los orificios del panel lateral izquierdo de 24" (11). Utilice tres pernos M6 x 45 mm (B) para asegurarlo. Repita la operación con el panel derecho de 24" (12). (Vea Diagrama 10)

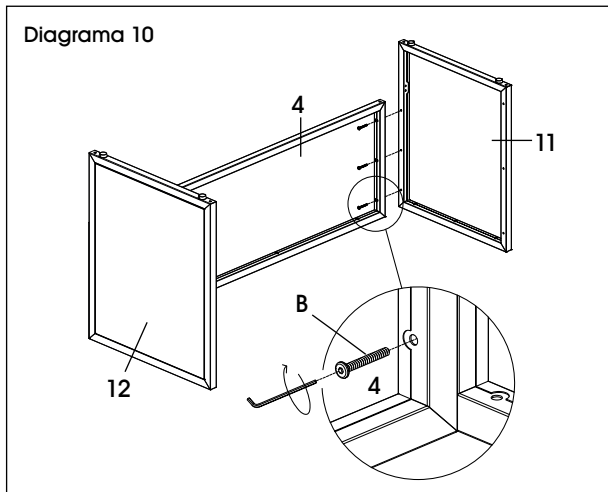

2. Coloque el panel de la cubierta de la credenza de 66 x 24" (10) boca abajo con los orificios hacia arriba. Con ayuda de otra persona, voltee el armazón ensamblado de la credenza al revés y alinéelo con los orificios del panel de la cubierta de la credenza. Utilice 12 pernos M6 x 45 mm (B) para asegurarlo. (Vea Diagrama 11)

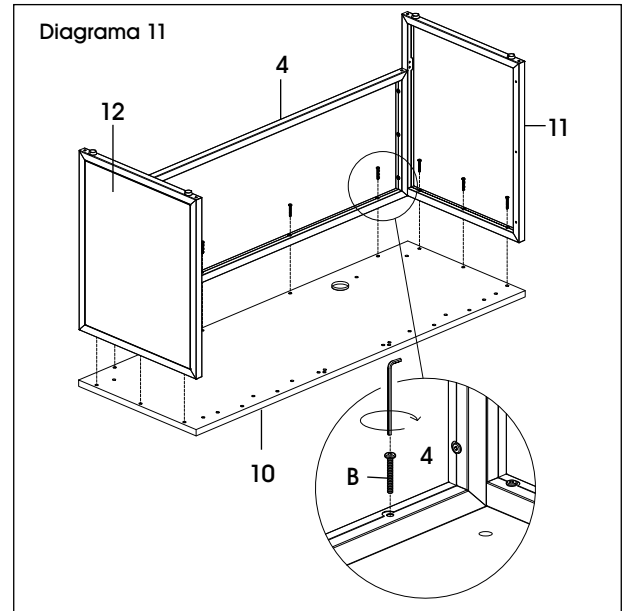

3. Inserte cuatro tornillos de hombro M6 x 14 mm (K) en el panel de cubierta de la credenza (10). (Vea Diagrama 12)

NOTA: Los tornillos de hombro no quedarán a ras con la cubierta del escritorio. Los tornillos sobresalen un poco de la cubierta para conectarlos con el archivero de pedestal.

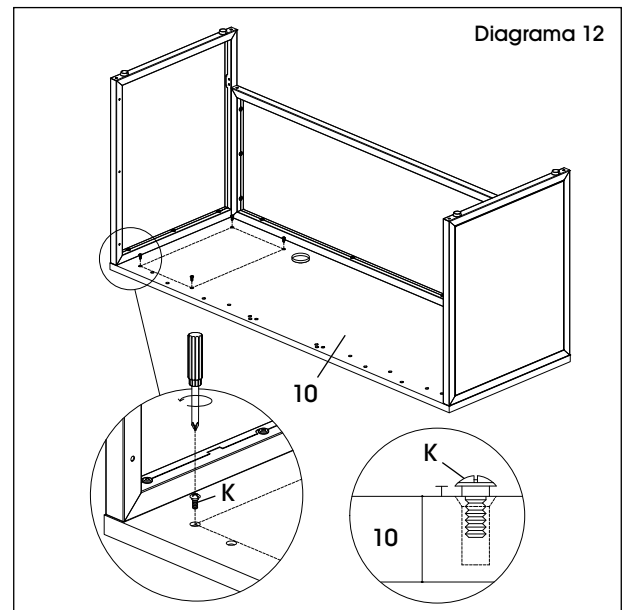

CONTINUACIÓN DE LAS INSTRUCCIONES DEL ESCRITORIO EN U

4. Con la ayuda de otra persona, voltee el archivero de pedestal (9) al revés. Baje con cuidado y alinee las pestañas con ranura tipo llave del archivero de pedestal con el tornillo de hombro (K) de la cubierta del retorno (10). (Vea Diagrama 13)



NOTA: El archivero de pedestal debe descansar sobre el panel de la cubierta de la credenza y colgar un poco sobre el borde frontal.

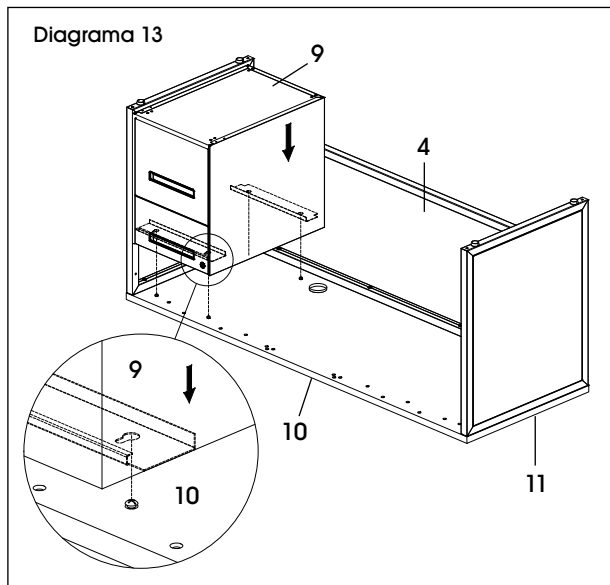

5. Empuje el archivero de pedestal (9) hacia el recato (4) para enganchar las pestañas con ranura tipo llave en los tornillos de hombro (K). (Vea Diagrama 14)

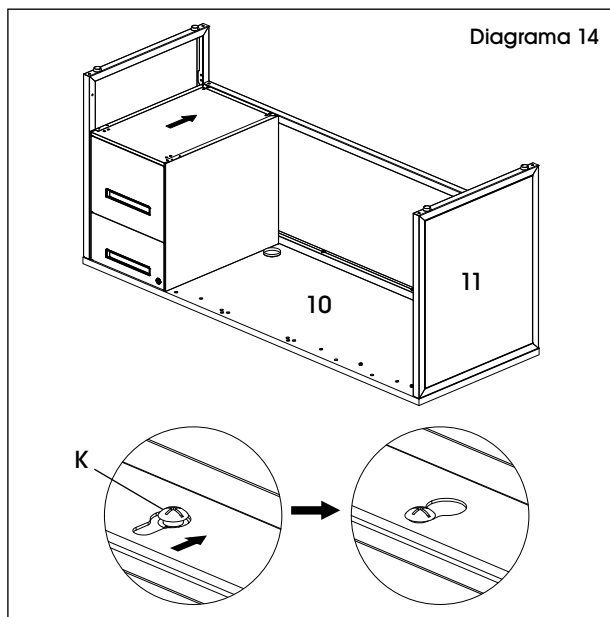

6. Fije la parte posterior del archivero de pedestal (9) al panel lateral con el Soporte en L derecho (J) y cuatro pernos M6 x 15 mm (F). Repita la operación en la parte frontal del archivero de pedestal con el Soporte en L izquierdo (I) y cuatro pernos M6 x 15 mm. (Vea Diagrama 15)

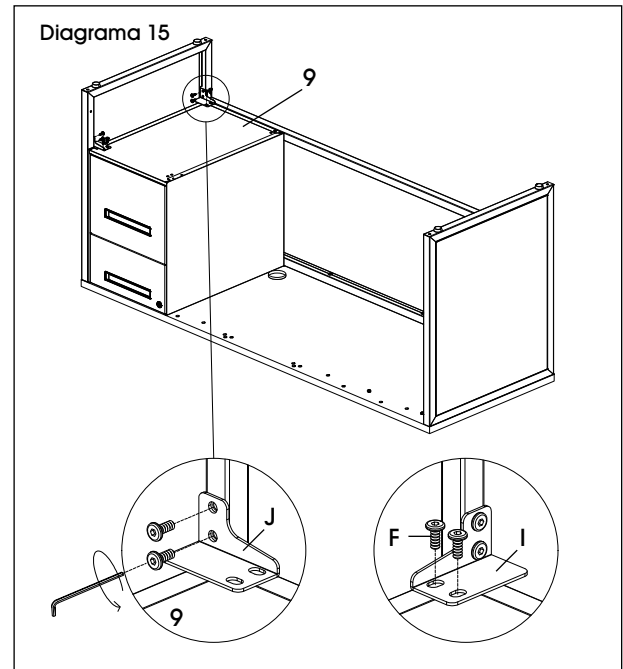

7. Fije la placa de unión (G) al panel de cubierta de la credenza (10) utilizando cuatro pernos M6 x 15 mm (F). (Vea Diagrama 16)

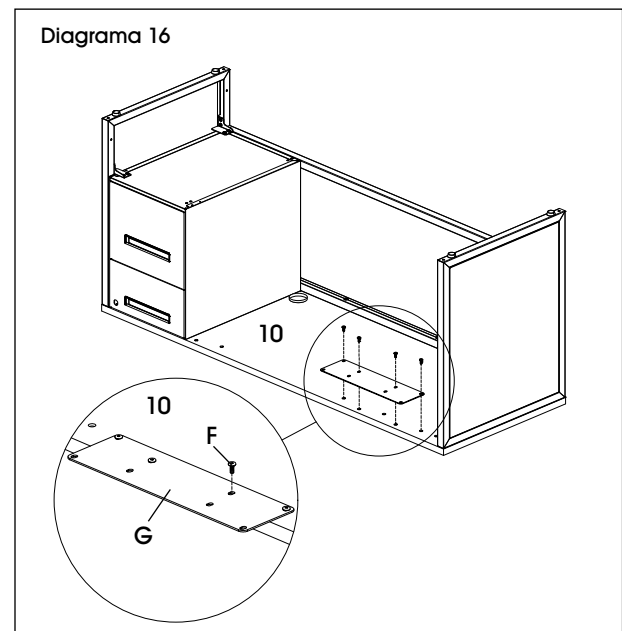

CONTINUACIÓN DE LAS INSTRUCCIONES DEL ESCRITORIO EN U

ENSAMBLE FINAL

 **NOTA:** Coloque los componentes ensamblados cerca el lugar deseado.

1. Entre dos personas enderecen la credenza ensamblada. Fije la placa de unión (G) al panel de cubierta del puente (13) utilizando cuatro pernos M6 x 15 mm (F). (Vea Diagrama 17)

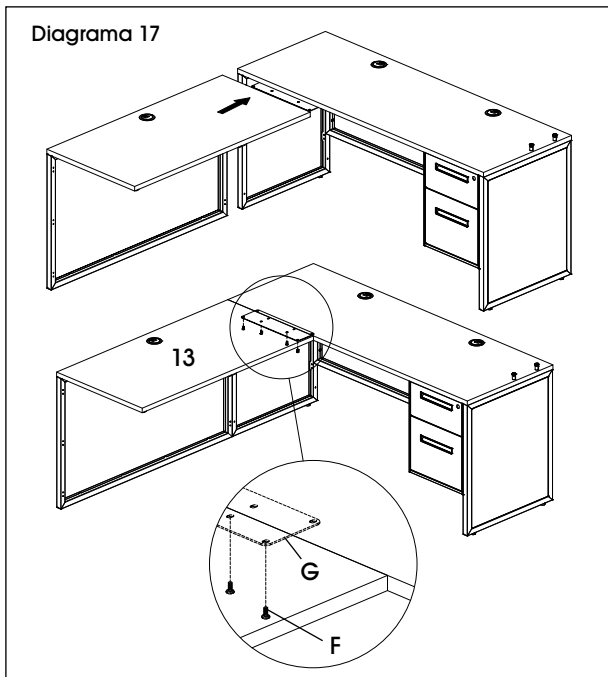

2. Fije un Soporte en I (H) con tres pernos M6 x 15 mm (F) para asegurar el recato del puente al panel lateral adyacente de la credenza. Repita la operación con los dos Soportes en I restantes. (Vea Diagrama 18)

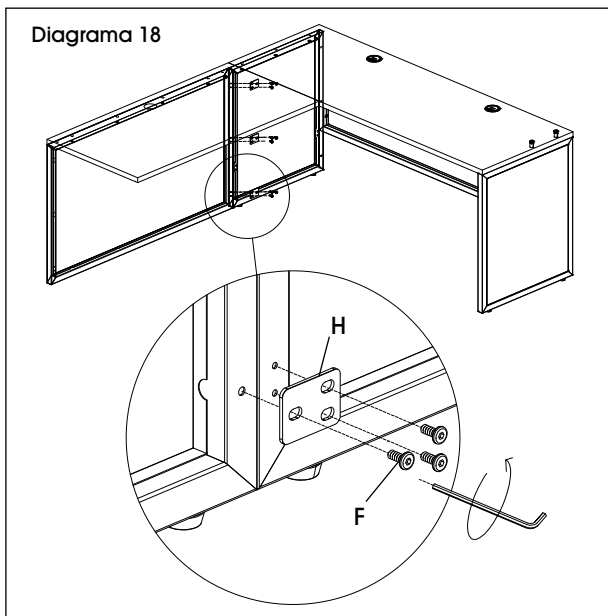

3. Con ayuda de otra persona, enderece el escritorio ensamblado y colóquelo al lado del puente. Fije la placa de unión (G) al panel de cubierta del puente (13) utilizando cuatro pernos M6 x 15 mm (F). (Vea Diagrama 19)

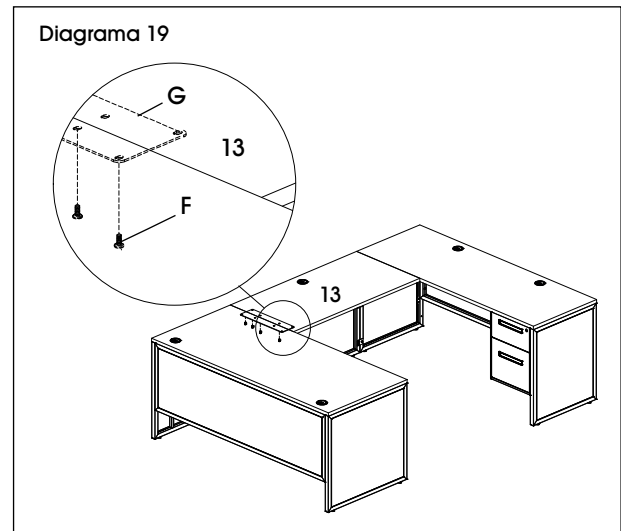

4. Asegure el puente al recato (14) y el panel lateral adyacente del escritorio con el Soporte en I (H) y tres pernos M6 x 15 mm (F). Repita la operación con los dos Soportes en I restantes. (Vea Diagrama 20)

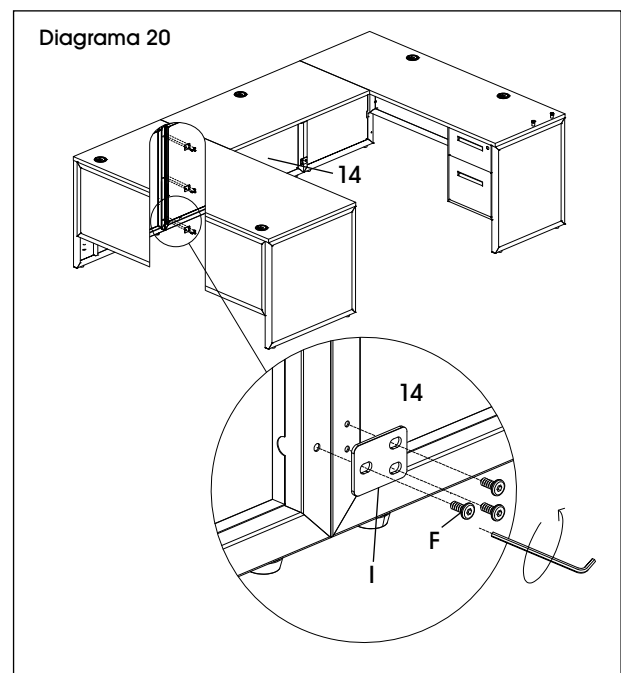

¡ALTO! Si ensambla el librero, proceda a la próxima página. Si no, el ensamble está terminado.

TORNILLERÍA DEL LIBRERO

B

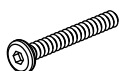

36 Pernos
M6 x 45 mm

F



32 Pernos
M6 x 15 mm

M

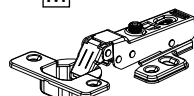

4 Bisagras

N



8 Tornillos para Bisagra
ST 3.5 x 14 mm

O



8 Pernos para Bisagra
M4 x 10 mm

P

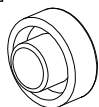

4 Llantas para
Puerta

Q

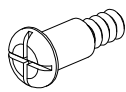

4 Pernos para Puerta
M6 x 14 mm

R

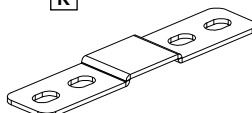

2 Soportes para Librero

S

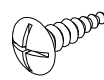

4 Tornillos para Madera
ST 4 x 18 mm

T

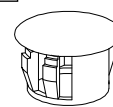

4 Tapas de
Plástico

2 Sets de Cerradura y Llave

U



1 Tornillos

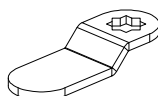

1 Placa de Bloqueo

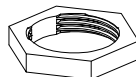

1 Tuerca Hexagonal

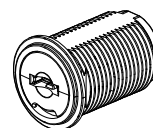

1 Cilindro

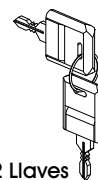

2 Llaves

PARTES DEL LIBRERO

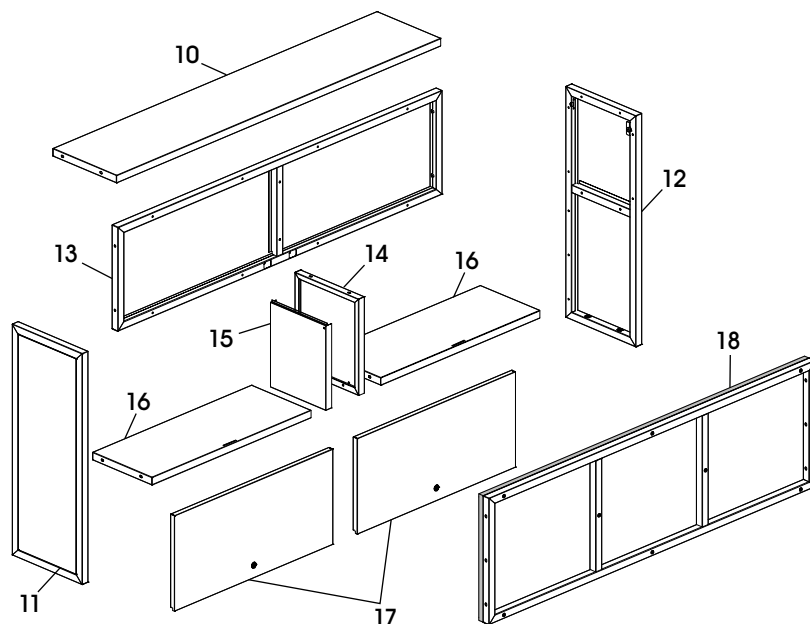

PARTES DEL LIBRERO

#	DESCRIPCIÓN	CANT.
10	Panel Superior	1
11	Panel Lateral Izquierdo	1
12	Panel Lateral Derecho	1
13	Panel Posterior	1
14	Panel Divisor Exterior	1
15	Panel Divisor Interior	1
16	Panel Inferior	2
17	Puerta	2
18	Tablero de Tela	1

INSTRUCCIONES DEL LIBRERO

ENSAMBLE

1. Voltee el panel superior (10). Alinee el panel posterior (13) con los orificios del panel superior. Apriete ligeramente cuatro pernos M6 x 15 mm (F). (Vea Diagrama 21)

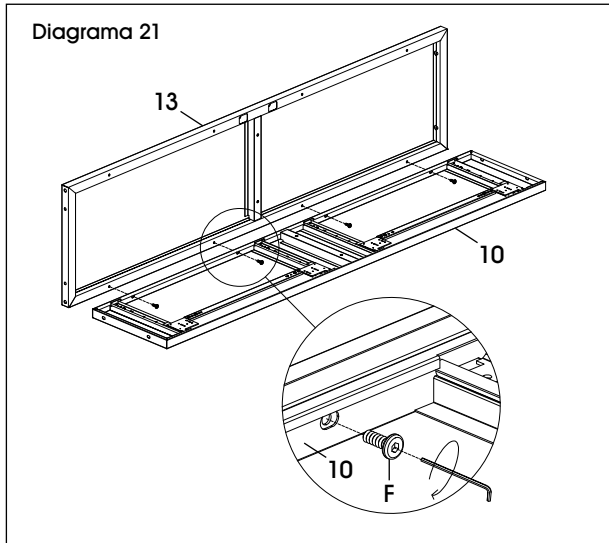

2. Inserte parcialmente dos pernos M6 x 15 mm (F) en el panel lateral izquierdo (11). Deje 1/8" de espacio entre las cabezas de los pernos y el panel. Alinee los pernos en el panel lateral izquierdo con las ranuras tipo llave en el panel superior (10). Inserte ambos pernos a través de las ranuras tipo llave. Jale el panel lateral izquierdo a través del panel superior para fijar los pernos en las ranuras tipo llaves. Apriete los pernos por completo. Repita la operación con el panel lateral derecho (12). (Vea Diagrama 22)

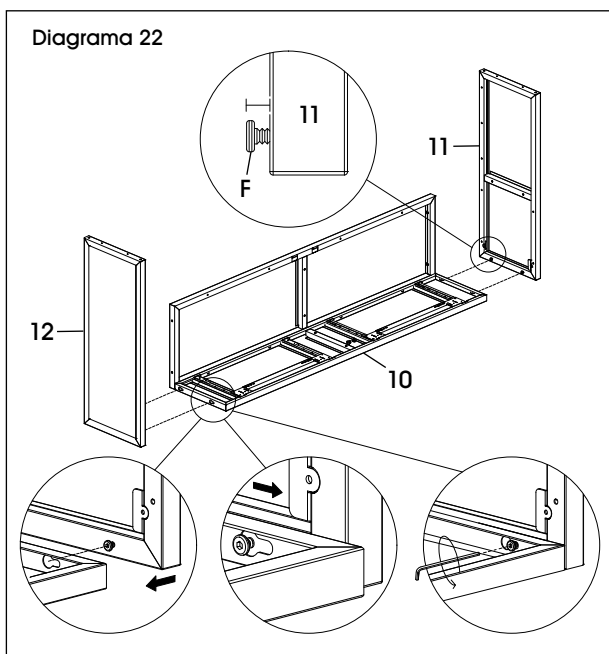

3. Inserte dos pernos M6 x 45 mm (B) para fijar el panel lateral izquierdo (11) al panel posterior (13). Apriete para asegurar. Repita la operación con el panel lateral derecho (12). Apriete cuatro pernos M6 x 15 mm del paso 1 en el panel superior (10). (Vea Diagrama 23)

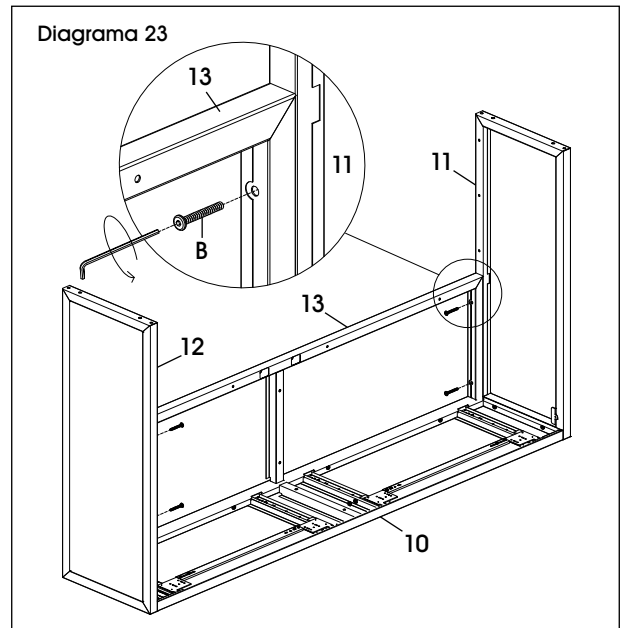

4. Coloque el panel divisor exterior (14) en el centro del librero y alinéelo con los orificios del panel superior (10) y el panel posterior (13). Use cuatro pernos de M6 x 15 mm (F) para fijarlos. (Vea Diagrama 24)

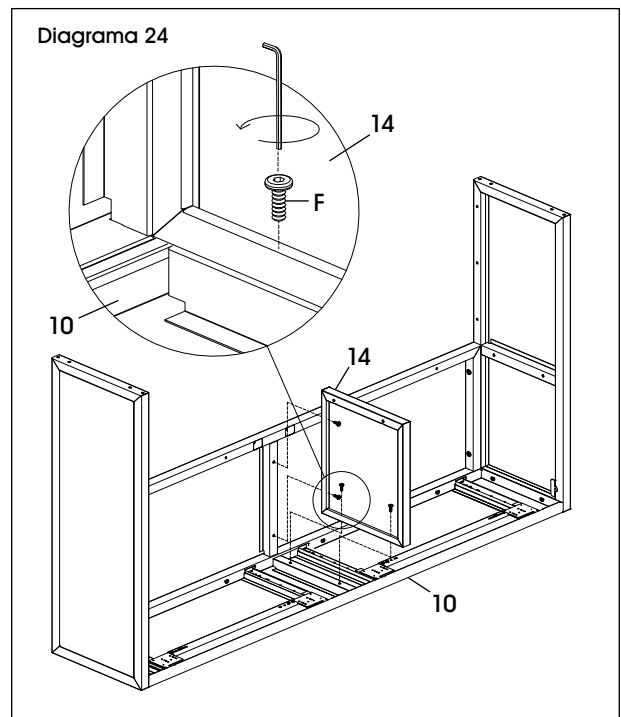

CONTINUACIÓN DE LAS INSTRUCCIONES DEL LIBRERO

5. Coloque el panel divisor interior (15) dentro del panel divisor exterior (14). Golpee ligeramente con un mazo de caucho para asegurarlo. Asegúrese de que los paneles divisores queden a ras unos con otros. (Vea Diagrama 25)

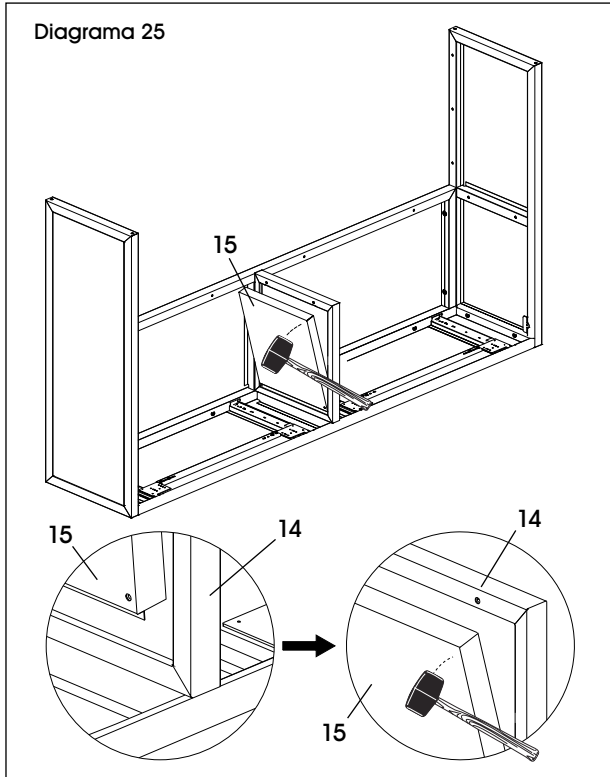

6. Alinee los paneles inferiores (16) con los orificios de los paneles laterales, panel posterior (13) y panel divisor exterior (14). (Vea Diagrama 26)

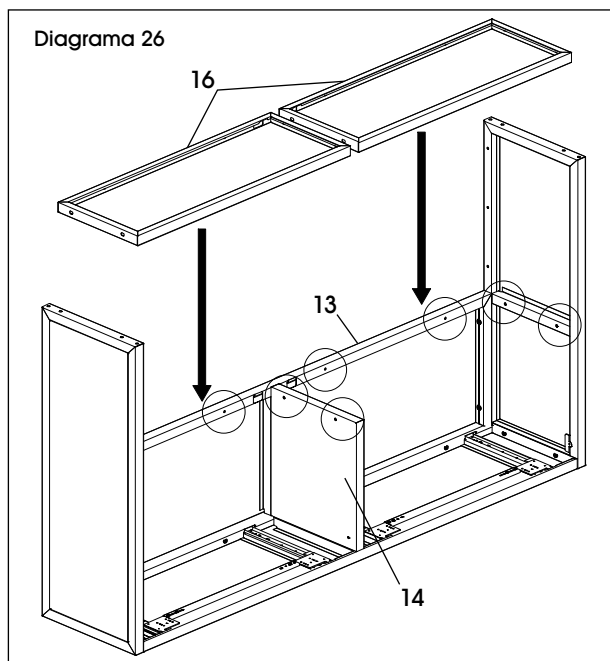

7. Asegure los paneles inferiores (16) utilizando 12 pernos M6 x 15 mm (F). (Vea Diagrama 27)

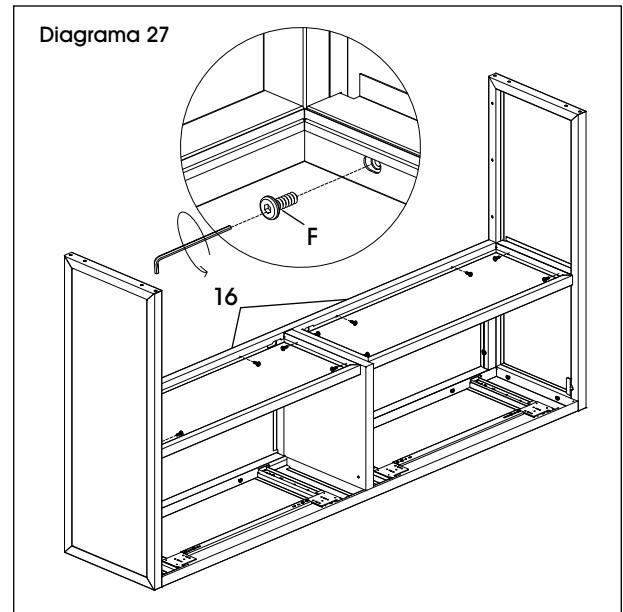

8. Fije las llantas para puertas (P) al interior del librero utilizando cuatro pernos para puertas M6 x 14 mm (Q). (Vea Diagrama 28)

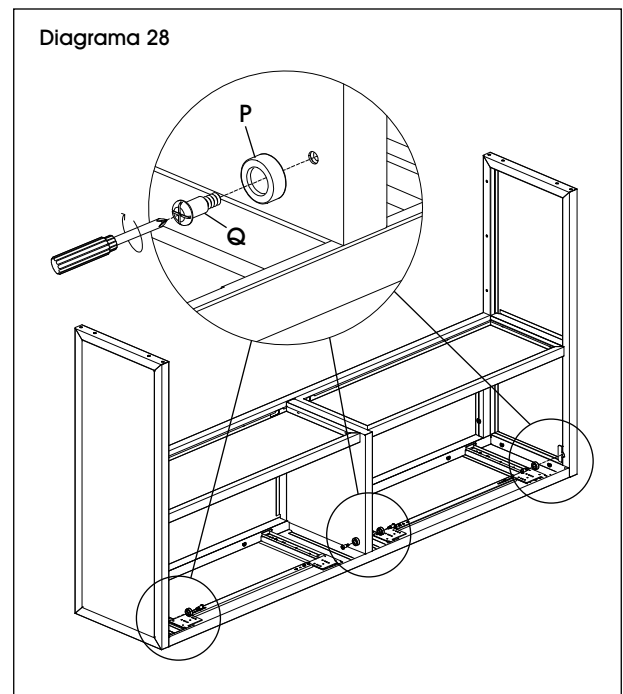

CONTINUACIÓN DE LAS INSTRUCCIONES DEL LIBRERO

9. Fije las bisagras (M) a las puertas (17) utilizando ocho tornillos para bisagra ST 3.5 x 14 mm (N). (Vea Diagrama 29)

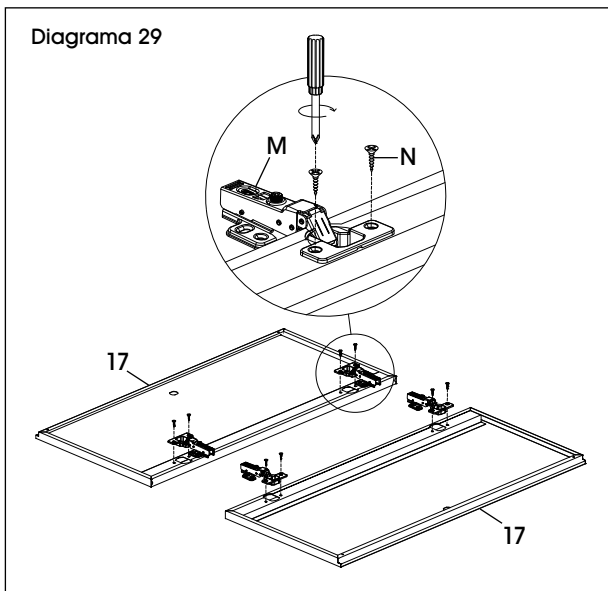

10. Retire la placa de bloqueo y la tuerca hexagonal del cilindro (U). Inserte el cilindro a través del orificio de la puerta y apriete la tuerca hexagonal alrededor del cilindro (U). Alinee la placa de la cerradura en el extremo del cilindro y fíjelo utilizando el tornillo (U). Repita con la puerta restante. (Vea Diagrama 30)



¡IMPORTANTE! Asegúrese de que las placas de la cerradura queden hacia abajo en la posición "con seguro" y hacia arriba en la posición "sin seguro".

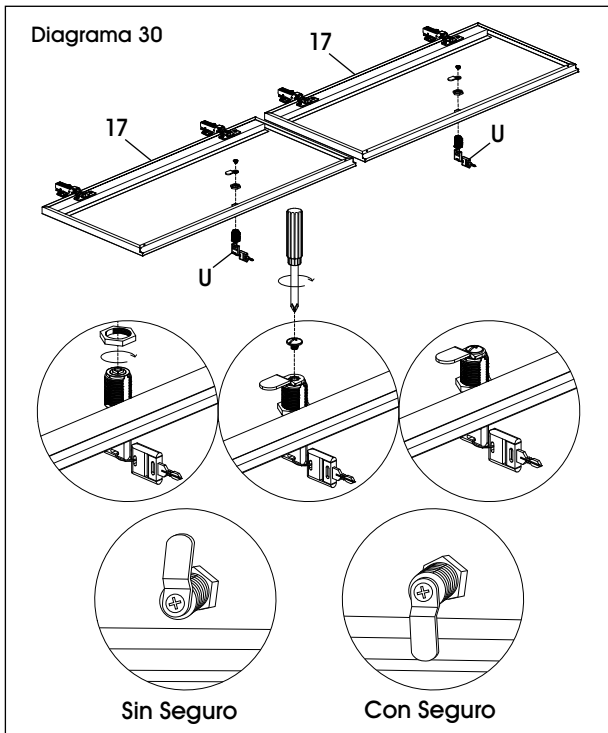

11. Alinee la bisagra (M) con los orificios del panel superior (10). Utilice dos pernos para bisagra M4 x 10 mm (O) para fijarla. Repita la operación con las otras tres bisagras. (Vea Diagrama 31)

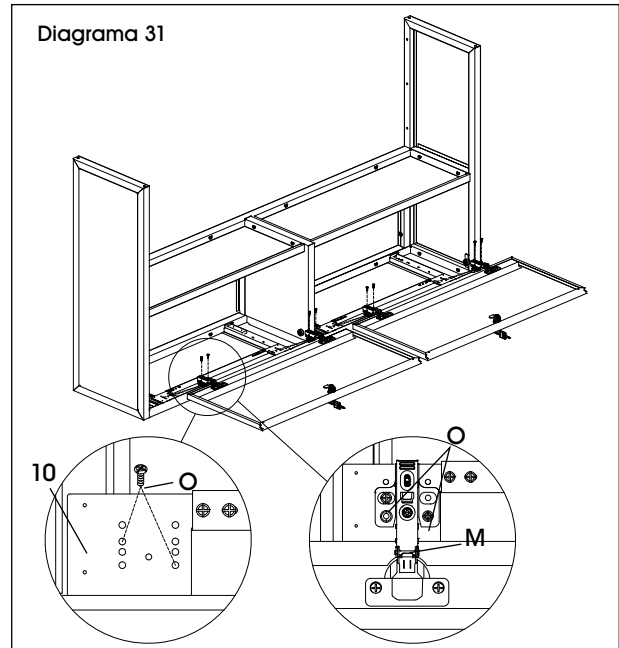

12. Ajuste las bisagras para alinear las puertas correctamente. (Vea Diagrama 32)

- **Ángulo de la puerta:** Suelte los tornillos para bisagra laterales, deslice la puerta hacia la izquierda o derecho, luego apriete el tornillo para asegurarlo.
- **Profundidad de la puerta:** Suelte el tornillo posterior de la bisagra, deslice la puerta hacia al frente o atrás, luego apriete el tornillo para asegurar.
- **Alto de la Puerta:** Apriete el tornillo central para bajar o suéltelo para levantar.

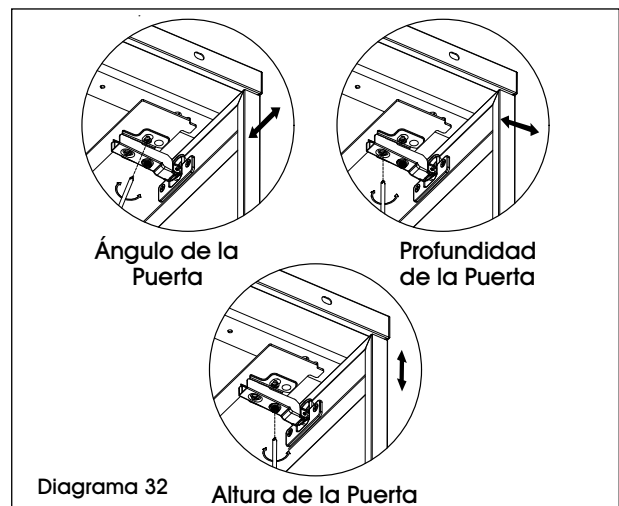

Si va a instalar el Tablero modelo Uline # H-10813, proceda al paso 13. Si no, siga al paso 14.

CONTINUACIÓN DE LAS INSTRUCCIONES DEL LIBRERO

13. Alinee el tablero (18) con los orificios en los paneles laterales. Utilice seis pernos M6 x 45 mm (B) para asegurarlo. (Vea Diagrama 33)

 **NOTA:** De ser necesario, golpee el tablero con un mazo de caucho para acomodarlo entre los paneles laterales.

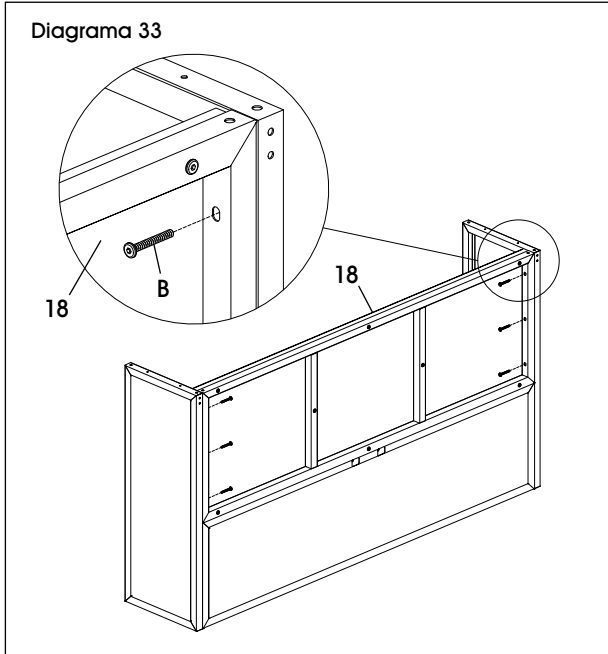

14. Con ayuda de otra persona, enderece el librero. Coloque con cuidado el librero sobre el escritorio (1), a ras con la parte posterior de la credenza. Fije los soportes para librero (R) a los paneles laterales de la credenza y los paneles laterales del librero utilizando ocho pernos M6 x 15 mm (F). (Vea Diagrama 34)

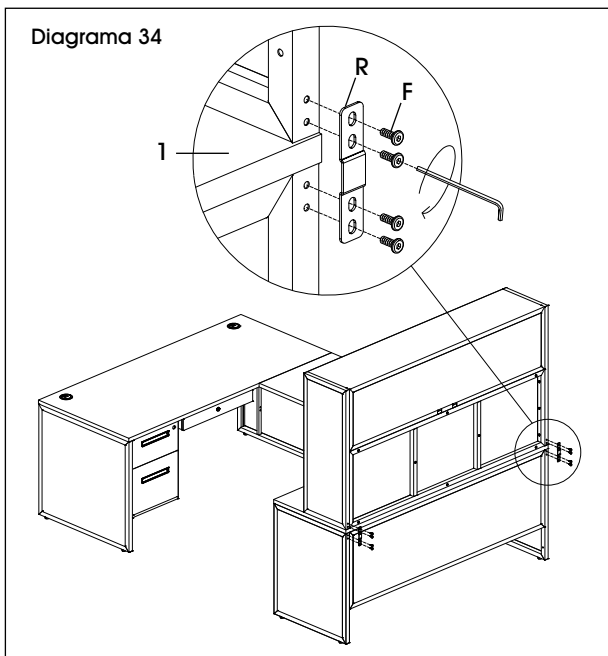

15. Asegure el librero utilizando cuatro tornillos ST4 x 18 mm (S) a través de los orificios de los paneles laterales del librero y en la cubierta. Apriete con el desarmador de cruz. (Vea Diagrama 35)

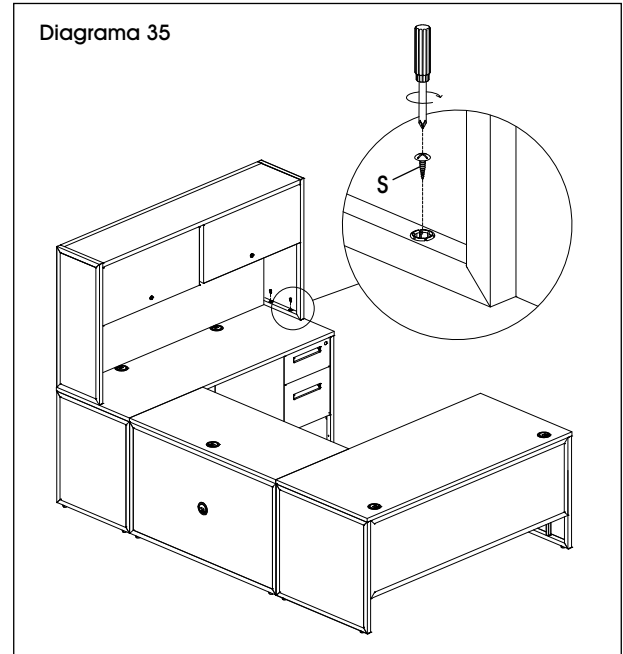

16. Inserte las tapas de plástico en los orificios para tornillos en el interior de los paneles laterales del librero. El ensamble está terminado. (Vea Diagrama 36)

 **NOTA:** Si fija una lámpara, proceda a la próxima página. Si no, el ensamble está terminado.

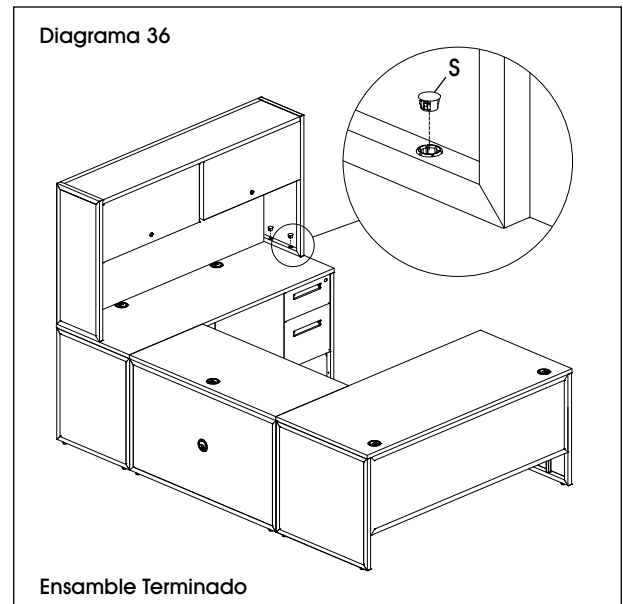

INSTALACIÓN DE LA LÁMPARA

La Lámpara LED Magnética (modelo Uline # H-7162) se puede fijar por debajo de cada gabinete superior utilizando los imanes de instalación integrados.

1. Alinee la lámpara por debajo del gabinete superior y los imanes la fijarán en su lugar. (Vea Diagrama 37)

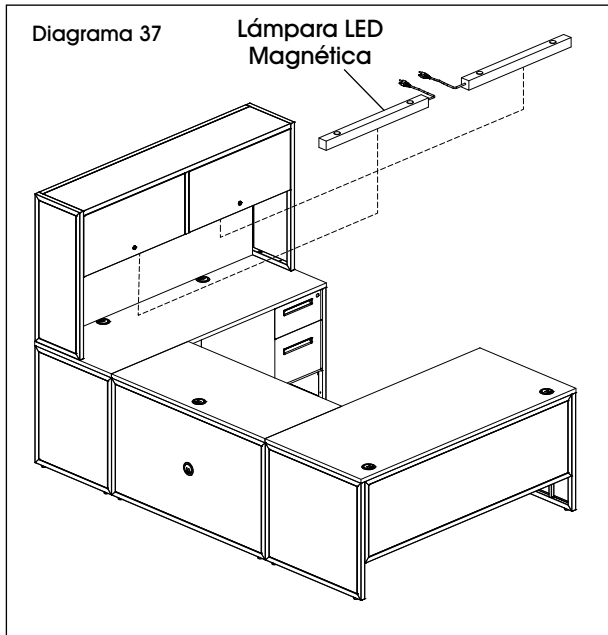

2. Alimente los extremos de enchufe por las aberturas detrás del librero. (Vea Diagrama 38)

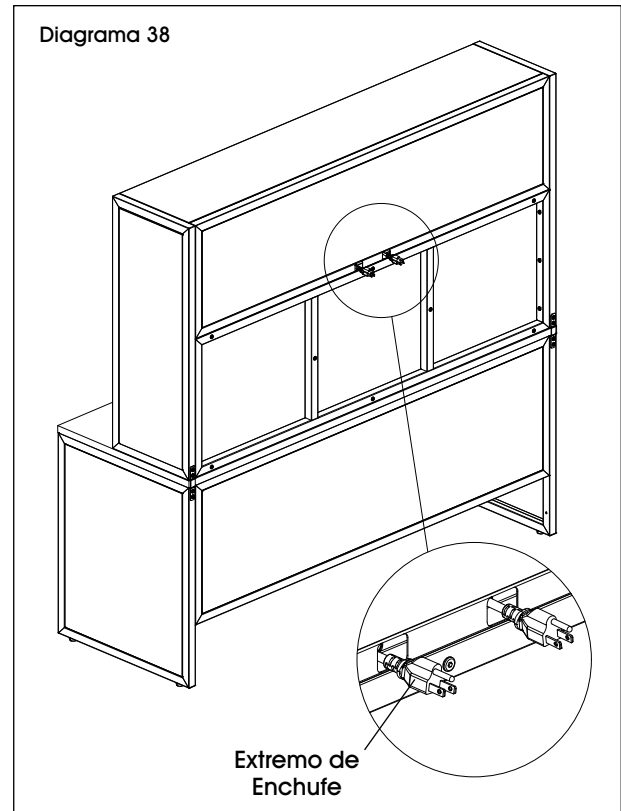
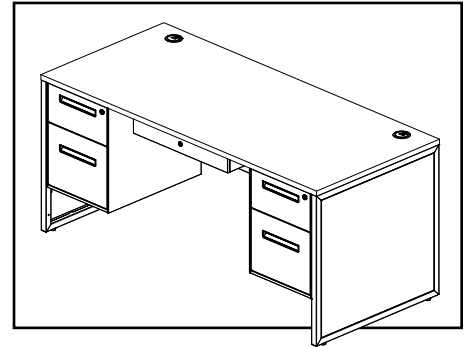
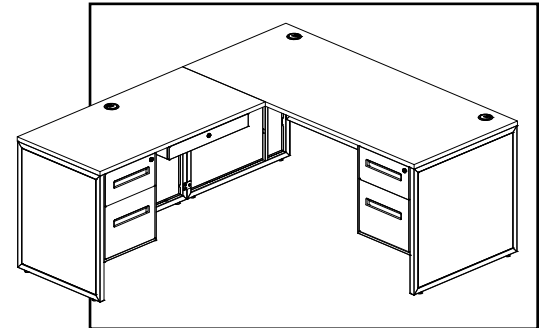

TABLE DES MATIÈRES**BUREAU**

Pages 44 à 46

H-9730**BUREAU EN L**

Pages 47 à 51

H-9731**BUREAU EN U, BUREAU EN U AVEC HUCHE**

Pages 52 à 63

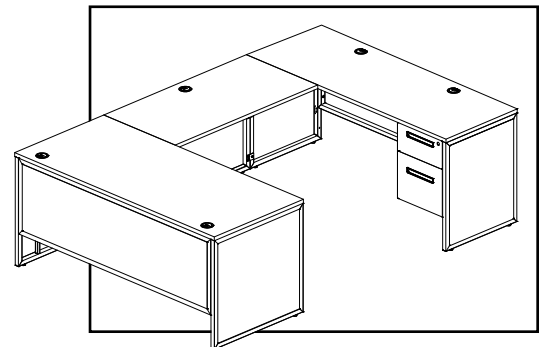
**H-12038
H-12039**

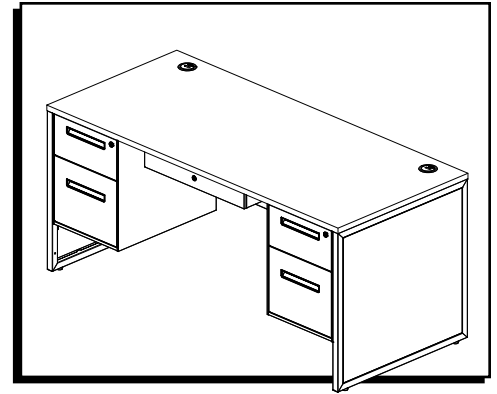

OUTILS REQUIS

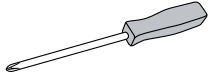

Tournevis cruciforme



Clé Allen (inclus)



Perceuse (optionnel)



Montage à deux personnes recommandé

MATÉRIEL DE FIXATION

A



Capuchon pour passe-fil x 2

B

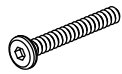

Boulon M6 x 45 mm x 18

C

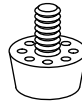

Patin de nivellement x 4

D

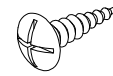

Vis à bois ST5 x 16 mm x 4

F



Boulon M6 x 15 mm x 16

I

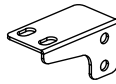

Support en L gauche x 2

J

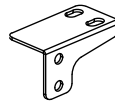

Support en L droit x 2

K

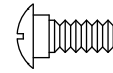

Vis à épaulement M6 x 14 mm x 8

PIÈCES

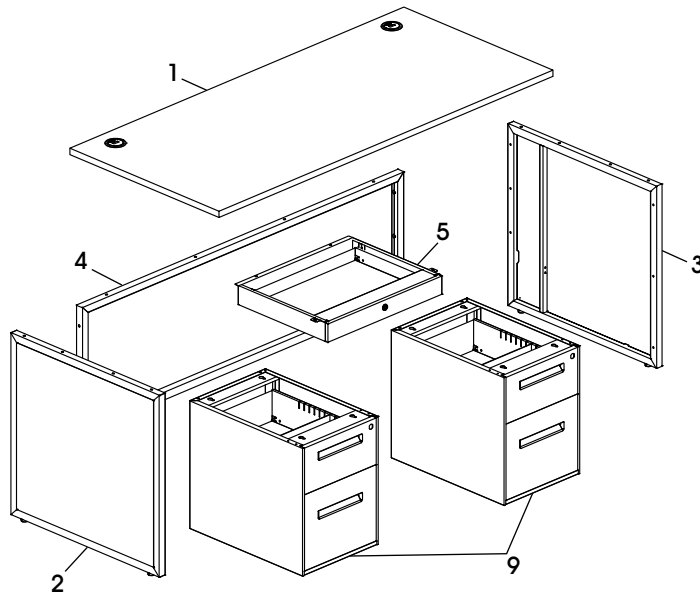

PIÈCES DU BUREAU

#	DESCRIPTION	QTÉ
1	Dessus de bureau	1
2	Panneau latéral gauche	1
3	Panneau latéral droit	1
4	Panneau cache-jambes	1
5	Tiroir central	1
9	Classeur à caisson	2

INSTRUCTIONS – BUREAU



IMPORTANT! Montez le bureau sur une surface lisse qui ne marque pas afin d'éviter les rayures.

REMARQUE : Vérifiez que toutes les pièces sont incluses.

REMARQUE : Utilisez la clé Allen pour serrer les boulons.

REMARQUE : Utilisez le tournevis cruciforme pour serrer les vis.

REMARQUE : Les patins de nivellement et les capuchons pour passe-fil sont préinstallés.

1. Alignez le panneau cache-jambes (4) sur les trous du panneau latéral (2). Fixez-le avec trois boulons M6 x 45 mm (B). Répétez la procédure pour l'autre panneau latéral. (Voir Figure 1)

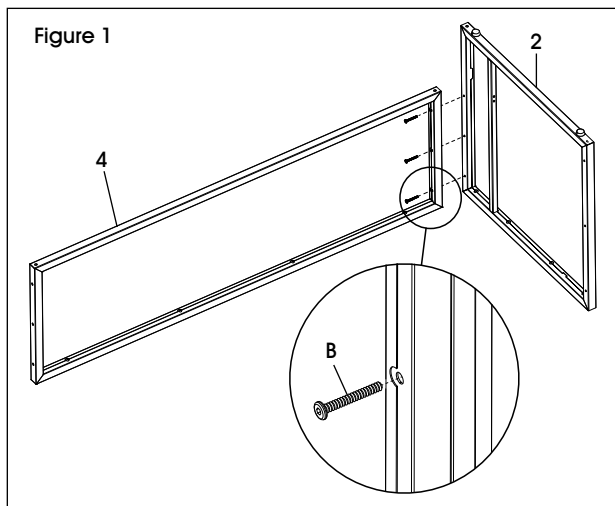

2. Placez le dessus de bureau (1) à l'envers sur une surface non marquante, les trous étant orientés vers le haut. À deux, retournez le cadre du bureau assemblé. Fixez le cadre au dessus de bureau avec 12 boulons M6 x 45 mm (B). (Voir Figure 2)

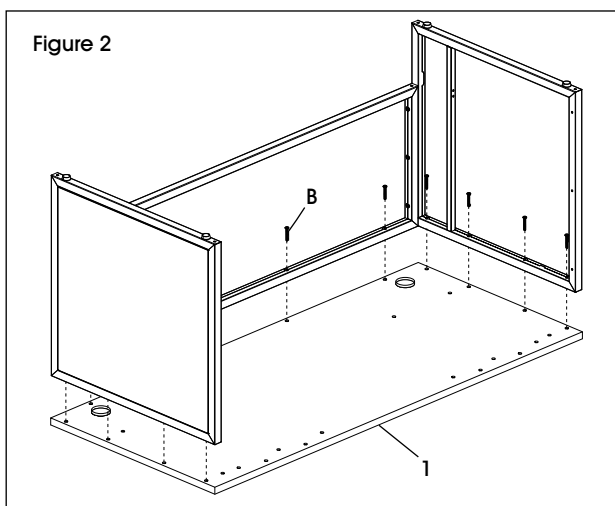

3. Insérez quatre vis à épaulement M6 x 14 mm (K) dans le dessus de bureau (1). (Voir Figure 3)



REMARQUE : Les vis à épaulement ne seront pas alignées avec le dessus de bureau. Les vis dépassent légèrement de la surface pour le raccordement au classeur à caisson.

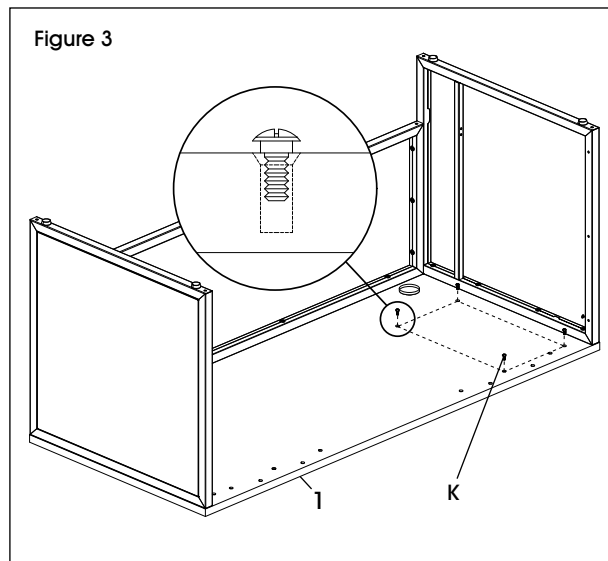

4. À deux, retournez le classeur à caisson (9). Abaissez soigneusement le classeur à caisson et alignez les onglets en trou de serrure du classeur à caisson sur les vis à épaulement (K) du dessus de bureau (1). (Voir Figure 4)



REMARQUE : Le classeur à caisson doit reposer sur le dessus de bureau et dépasser légèrement du bord avant.

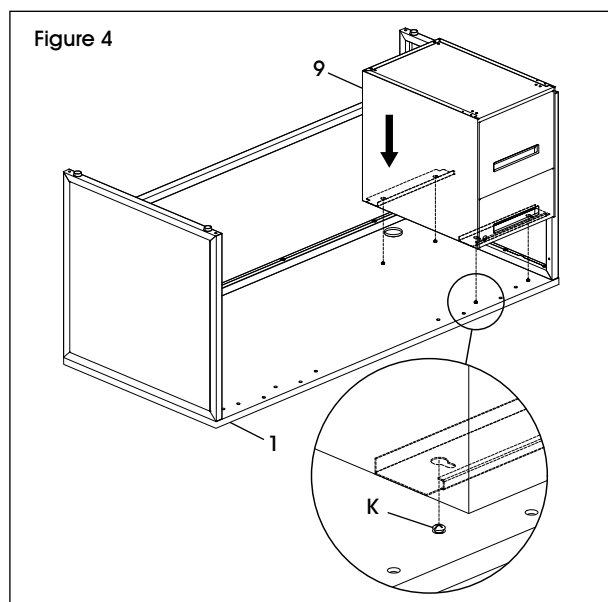

INSTRUCTIONS – BUREAU – SUITE

5. Poussez le classeur à caisson (9) vers le panneau cache-jambes (4) pour accrocher les onglets en trou de serrure sur les vis à épaulement (K). (Voir Figure 5)

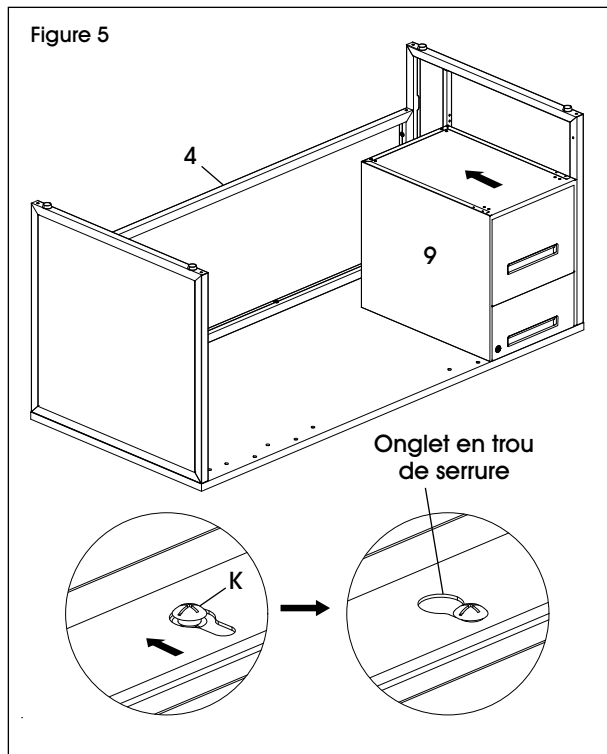

6. Fixez l'arrière du classeur à caisson (9) au panneau latéral avec le support en L gauche (I) et quatre boulons M6 x 15 mm (F). Répétez la procédure à l'avant du classeur à caisson avec le support en L droit (J) et quatre boulons M6 x 15 mm. (Voir Figure 6)

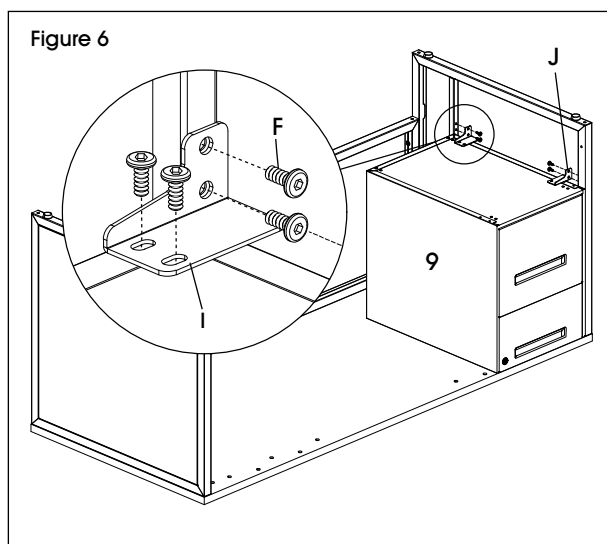

7. Répétez les étapes 4 à 7 pour installer l'autre classeur à caisson du côté opposé.

8. Placez le tiroir central (5) à l'envers à l'emplacement souhaité sur la surface de bureau. Fixez-le avec quatre vis à bois autotaraudeuses ST 5 x 16 mm (D). (Voir Figure 7)



REMARQUE : Les trous préfiletés sur le dessus de bureau ne doivent pas être utilisés pour la fixation du tiroir.



REMARQUE : Les trous du tiroir peuvent être prépercés avec la perceuse (optionnel).



REMARQUE : Il est recommandé de positionner le tiroir au ras du bord avant du dessus de bureau.

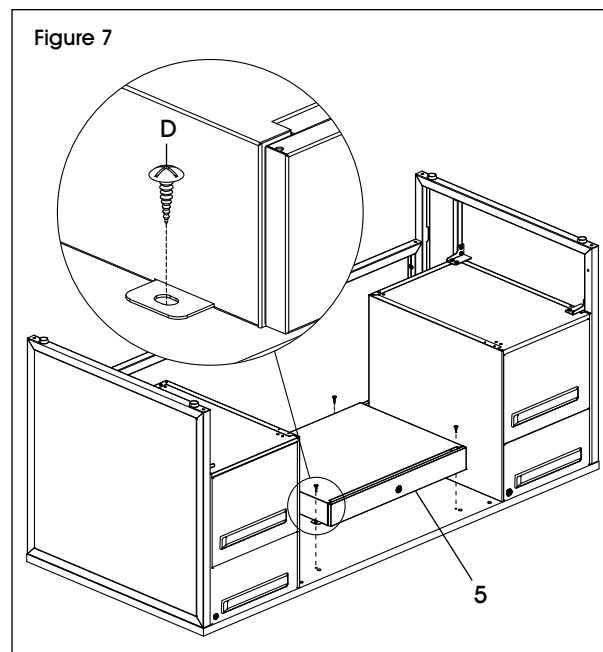

9. À deux, mettez le bureau à l'endroit. Ajustez les patins pour compenser les inégalités du sol. Le montage est terminé. (Voir Figure 8)

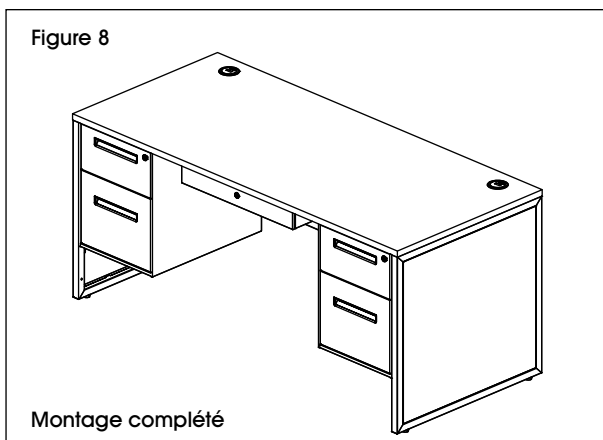

ULINE

1 800 295-5510
uline.ca

ULINE H-9731

BUREAU EN L

1 800 295-5510
uline.ca

OUTILS REQUIS

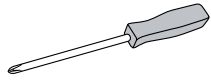

Tournevis cruciforme



Clé Allen (inclus)



Perceuse (optionnel)



Montage à deux personnes recommandé

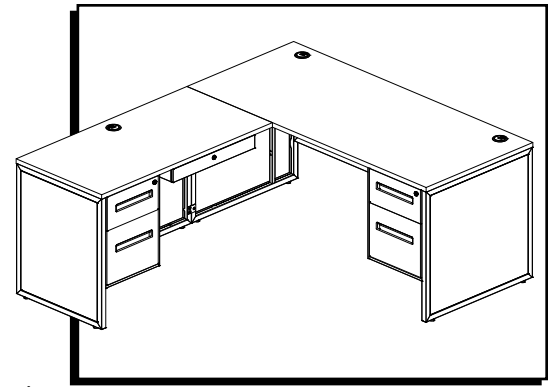

MATÉRIEL DE FIXATION

A



Capuchon pour passe-fil x 4

B

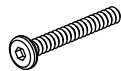

Boulon M6 x 45 mm x 28

C



Patin de nivellement x 8

D

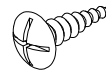

Vis à bois ST 5 x 16 mm x 4

F

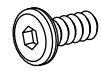

Boulon M6 x 15 mm x 33

G

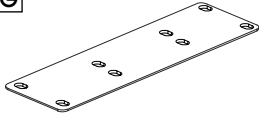

Plaque de connexion x 1

H

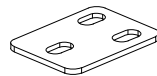

Support en I x 3

I

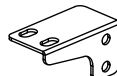

Support en L gauche x 2

J

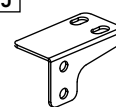

Support en L droit x 2

K

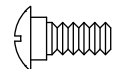

Vis à épaulement M6 x 14 mm x 8

PIÈCES

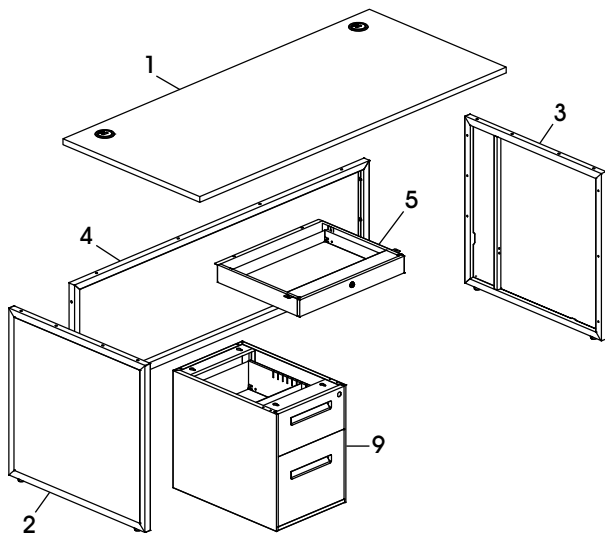

PIÈCES DU BUREAU EN L

#	DESCRIPTION	QTÉ
1	Dessus de bureau	1
2	Panneau latéral gauche	1
3	Panneau latéral droit	1
4	Panneau cache-jambes	1
5	Tiroir central	1
9	Classeur à caisson	1

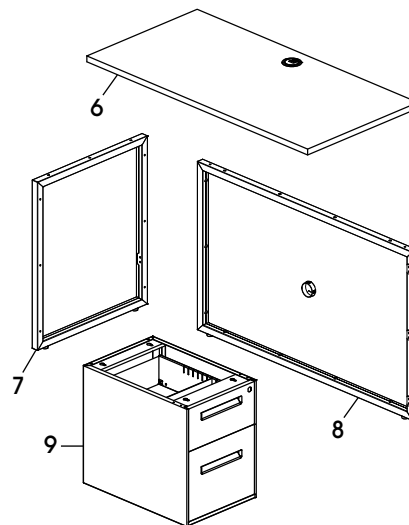

PIÈCES DU RETOUR

#	DESCRIPTION	QTÉ
6	Dessus de bureau du retour	1
7	Panneau latéral du retour	1
8	Panneau cache-jambes du retour	1
9	Classeur à caisson	1

INSTRUCTIONS – BUREAU EN L



IMPORTANT! Montez le bureau sur une surface lisse qui ne marque pas afin d'éviter les rayures.

REMARQUE : Vérifiez que toutes les pièces sont incluses.

REMARQUE : Utilisez la clé Allen pour serrer les boulons.

REMARQUE : Utilisez le tournevis cruciforme pour serrer les vis.

REMARQUE : Les patins de nivellement et les capuchons pour passe-fil sont préinstallés.

MONTAGE DU BUREAU

1. Alignez le panneau cache-jambes (4) sur les trous du panneau latéral (2). Fixez-le avec trois boulons M6 x 45 mm (B). Répétez la procédure pour le panneau latéral opposé. (Voir Figure 1)

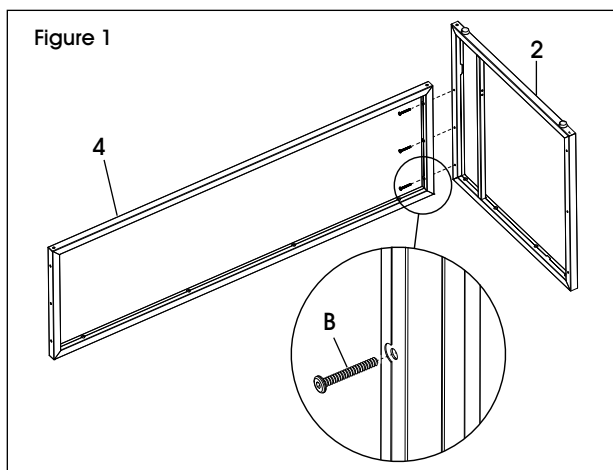

2. Placez le dessus de bureau (1) à l'envers sur une surface non marquante, les trous étant orientés vers le haut. À deux, retournez le cadre du bureau assemblé. Fixez le cadre au dessus de bureau avec 12 boulons M6 x 45 mm (B). (Voir Figure 2)

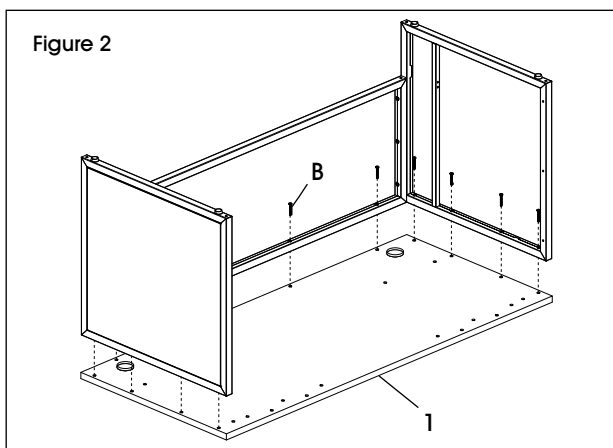

ARRÊT : Déterminez si le bureau en L sera configuré à droite ou à gauche. Cela a un impact sur la façon dont le retour est assemblé. Le montage du bureau en L configuré à droite est indiqué dans les illustrations suivantes.

3. Fixez le classeur à caisson du côté droit du dessus de bureau (1) lorsqu'il est à l'envers. Insérez quatre vis à épaulement M6 x 14 mm (K) dans le dessus de bureau et serrez-les avec le tournevis cruciforme. (Voir Figure 3)



REMARQUE : Les vis à épaulement ne seront pas alignées avec le dessus de bureau. Les vis dépassent légèrement du dessus de bureau pour le raccordement au classeur à caisson.

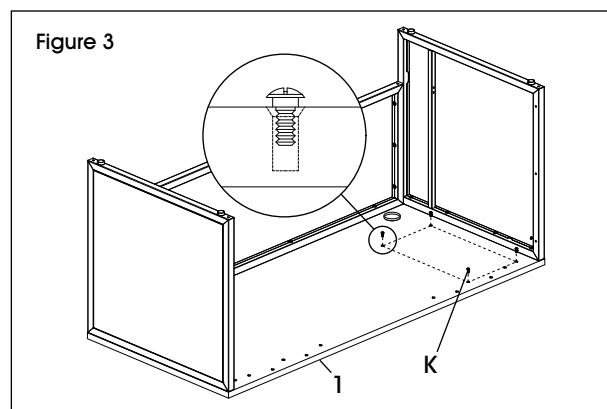

4. À deux, retournez le classeur à caisson (9). Abaissez-le soigneusement et alignez les onglets en trou de serrure du classeur à caisson sur les vis à épaulement (K) du dessus de bureau (1). (Voir Figure 4)



REMARQUE : Le classeur à caisson doit reposer sur le dessus de bureau et dépasser légèrement du bord avant.

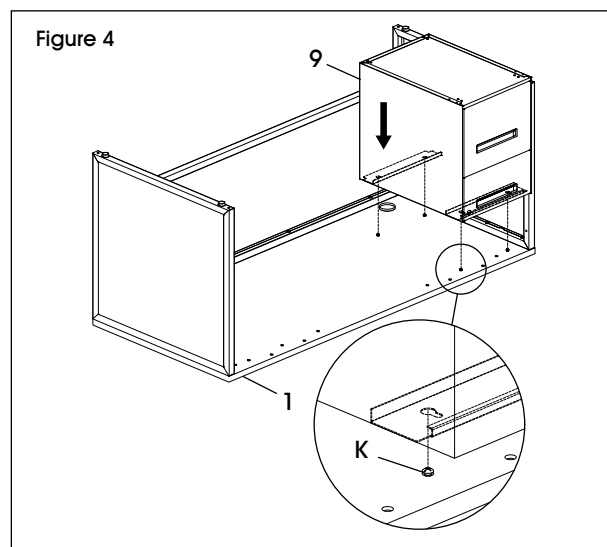

- Fixez l'arrière du classeur à caisson (9) au panneau latéral avec le support en L gauche (I) et quatre boulons M6 x 15 mm (F). Répétez la procédure à l'avant du classeur à caisson avec le support en L droit (J) et quatre boulons M6 x 15 mm. (Voir Figure 5)

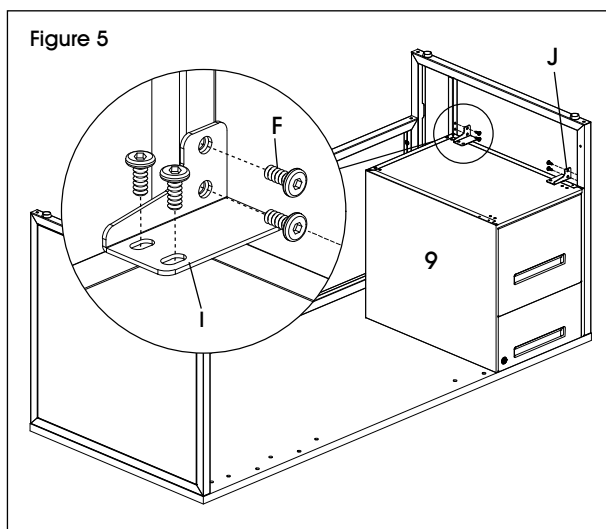

- Fixez la plaque de connexion (G) au dessus de bureau (1) avec quatre boulons M6 x 15 mm (F). (Voir Figure 6)

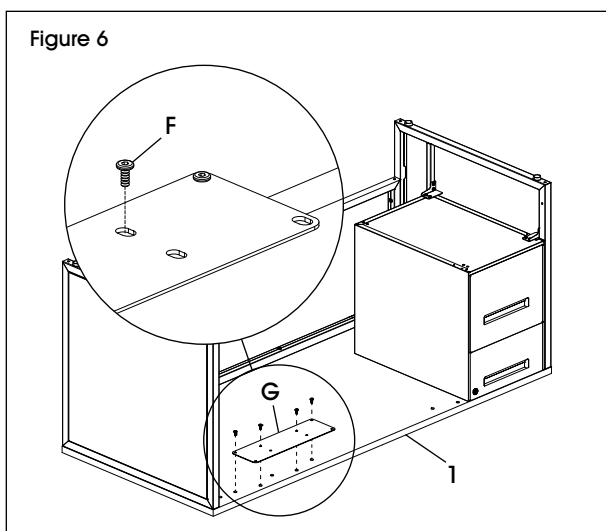

- À deux, mettez le bureau à l'endroit.

REMARQUE : Avant de continuer, assurez-vous que le bureau est positionné à l'endroit où il sera utilisé. Le bureau est difficile à déplacer lorsqu'il est complètement monté.

MONTAGE DU RETOUR

- Alignez le panneau cache-jambes du retour (8) sur les trous du panneau latéral du retour (7). Fixez-le avec trois boulons M6 x 45 mm (B). (Voir Figure 7)

REMARQUE : Pour une configuration du bureau en L à gauche, le panneau latéral du retour doit être fixé sur le côté opposé du panneau cache-jambes du retour.

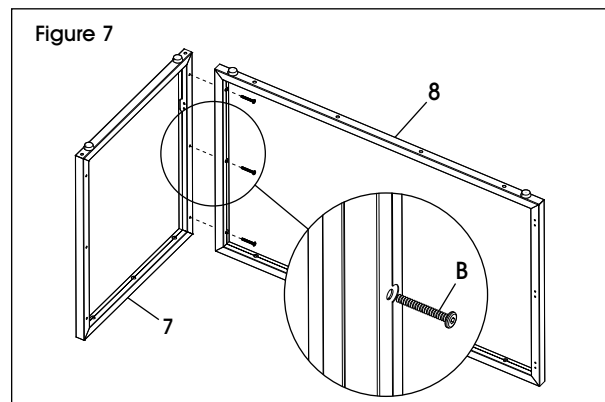

- Placez le dessus de bureau du retour (6) à l'envers, avec les trous orientés vers le haut. À deux, retournez le cadre du bureau en L assemblé. Fixez le cadre au dessus de bureau avec sept boulons M6 x 45 mm (B). (Voir Figure 8)

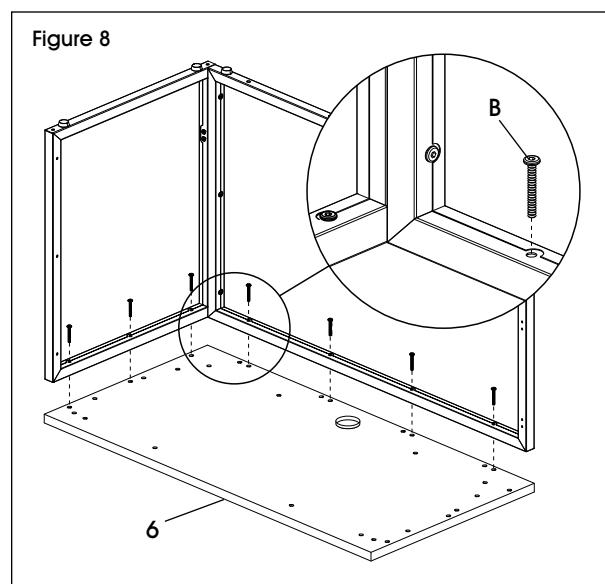

INSTRUCTIONS – BUREAU EN L – SUITE

3. Insérez quatre vis à épaulement M6 x 14 mm (K) pour le classeur à caisson dans le dessus du retour (6).
(Voir Figure 9)

 **REMARQUE :** Les vis à épaulement (K) ne seront pas alignées avec le dessus de bureau (6). Les vis dépassent légèrement du dessus de bureau pour permettre le raccordement au classeur à caisson.

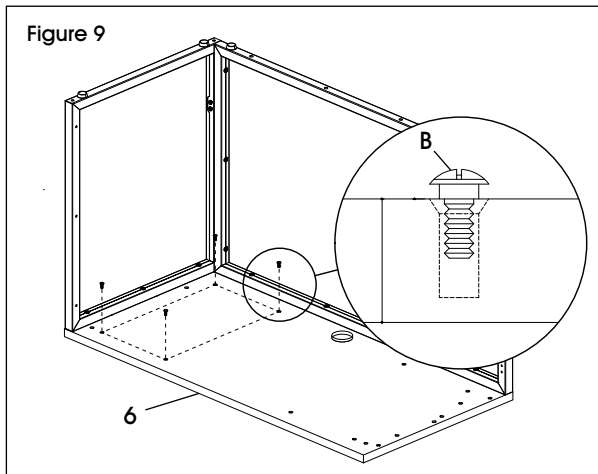

4. À deux, retournez le classeur à caisson (9). Abaissez soigneusement le classeur à caisson et alignez les onglets en trou de serrure du classeur à caisson sur les vis à épaulement (K) du dessus de bureau du retour (6). (Voir Figure 10)

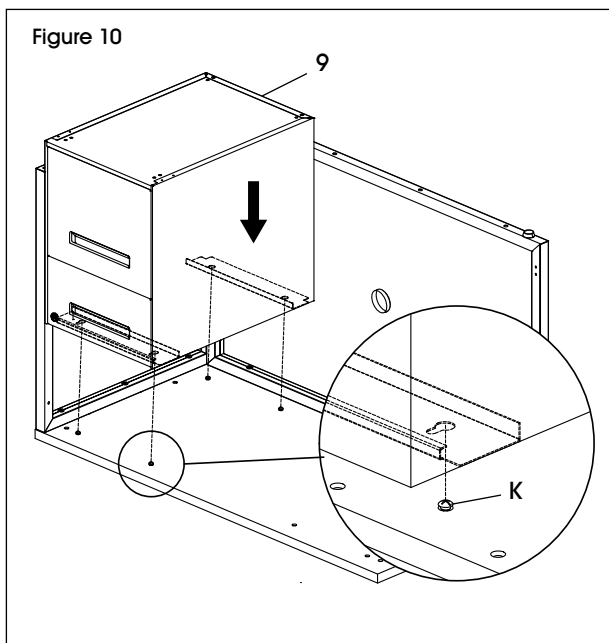

5. Poussez le classeur à caisson (9) vers le panneau cache-jambes du retour (8) pour accrocher les onglets en trou de serrure sur les vis à épaulement (K).
(Voir Figure 11)

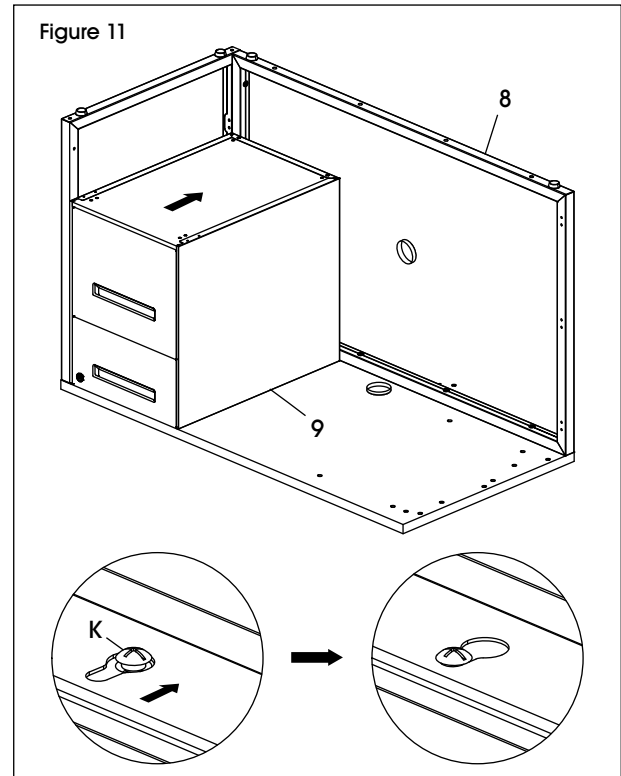

6. Fixez l'arrière du classeur à caisson (9) au panneau latéral du retour avec le support en L droit (J) et quatre boulons M6 x 15 mm (F). Répétez la procédure à l'avant du classeur à caisson avec le support en L gauche et quatre boulons M6 x 15 mm.
(Voir Figure 12)

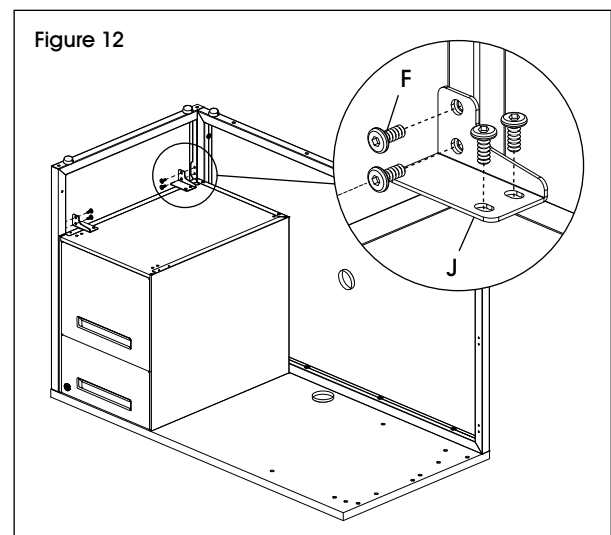

MONTAGE FINAL

1. À deux, retournez le retour de bureau en L et placez-le à côté du bureau assemblé. Fixez la plaque de connexion (G) au dessus du retour (6) avec quatre boulons M6 x 15 mm (F). (Voir Figure 13)

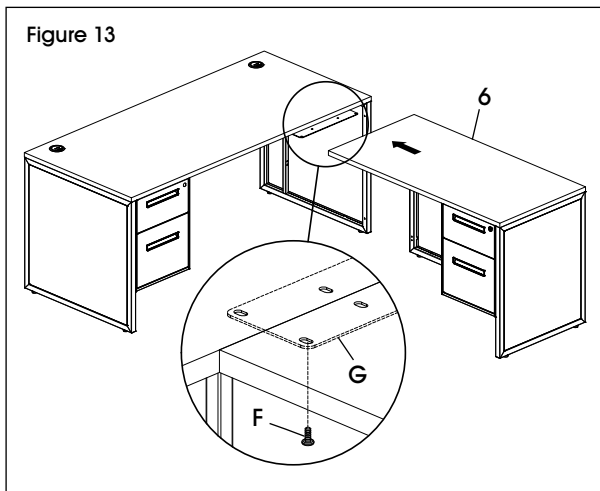

2. Fixez un support en I (H) au panneau cache-jambes du retour et au panneau latéral adjacent avec trois boulons M6 x 15 mm (F). Répétez la procédure pour les deux autres supports en I. (Voir Figure 14)

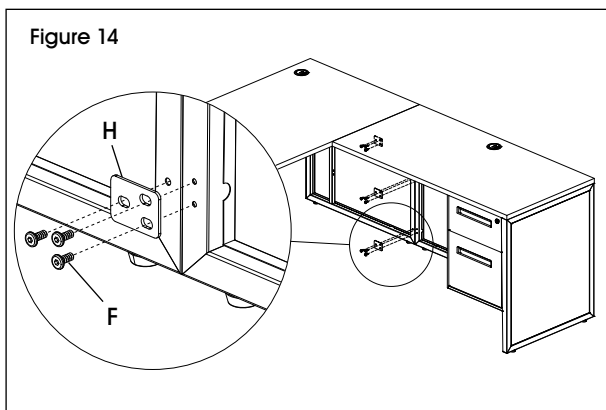

3. À deux, maintenez le tiroir central (5) à l'emplacement souhaité sur le dessus de bureau ou le dessus du retour. Fixez-le avec quatre vis à bois autotaraudeuses ST 5 x 16 mm (D). (Voir Figure 15)



REMARQUE : Les trous préfiletés sur le dessus de bureau ne doivent pas être utilisés pour la fixation du tiroir.



REMARQUE : Les trous du tiroir peuvent être prépercés avec la perceuse. (optionnel)



REMARQUE : Il est recommandé de positionner le tiroir au ras du bord avant du dessus de bureau.

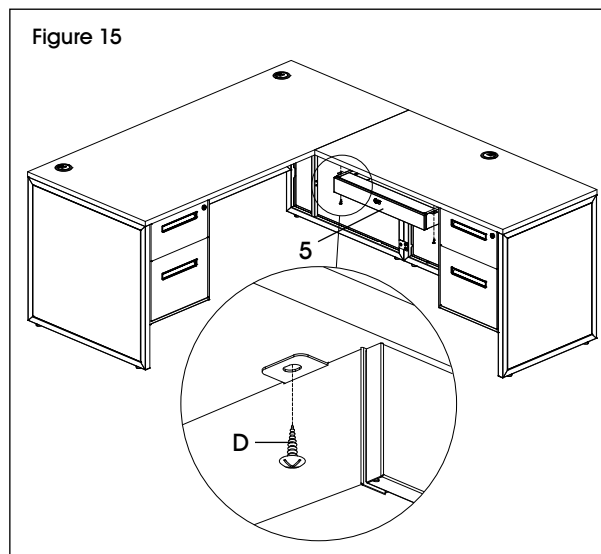

4. Insérez quatre capuchons pour passe-fil dans le dessus de bureau, le dessus du retour et le panneau cache-jambes du retour. Ajustez les patins pour compenser les inégalités du sol. Le montage est terminé. (Voir Figure 16)

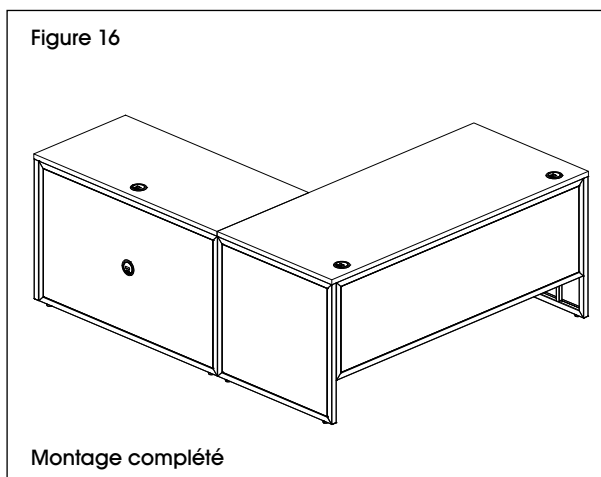

ULINE

1 800 295-5510
uline.ca

ULINE H-12038, H-12039

BUREAU EN U

1 800 295-5510

uline.ca

OUTILS REQUIS

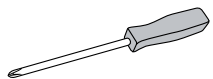

Tournevis cruciforme



Clé Allen
(inclus)



Perceuse
(optionnel)



Maillet en caoutchouc



Montage à deux
personnes recommandé

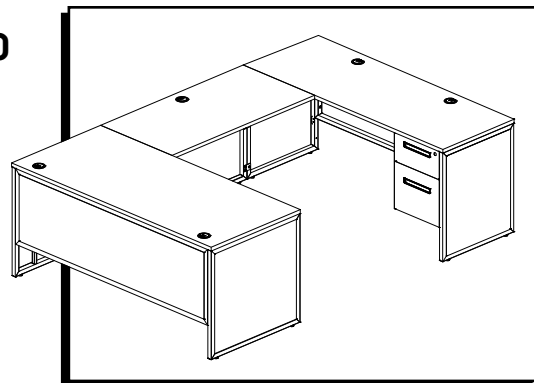

MATÉRIEL DE FIXATION

A



Capuchon pour passe-fil
x 6

B

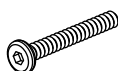

Boulon M6 x 45 mm
x 36

C

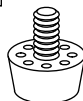

Patin de nivellement
x 10

D

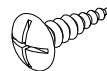

Vis à bois ST 5 x 16 mm
x 4

F



Boulon M6 x 15 mm
x 50

G

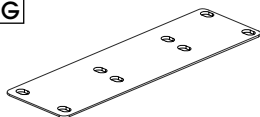

Plaque de connexion
x 2

H

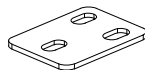

Support en I
x 6

I

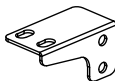

Support en L gauche
x 2

J

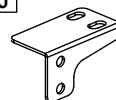

Support en L droit
x 2

K

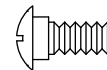

Vis à épaulement M6 x 14 mm
x 8

PIÈCES

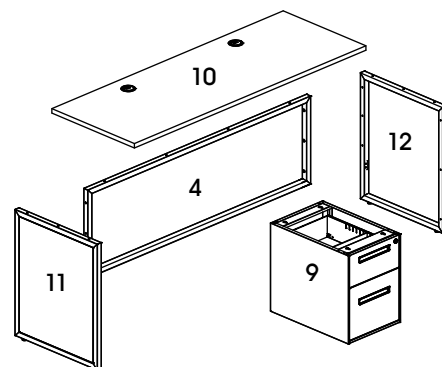
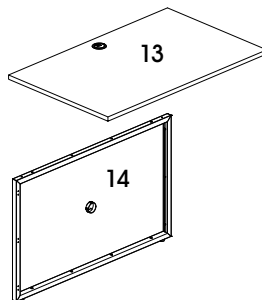
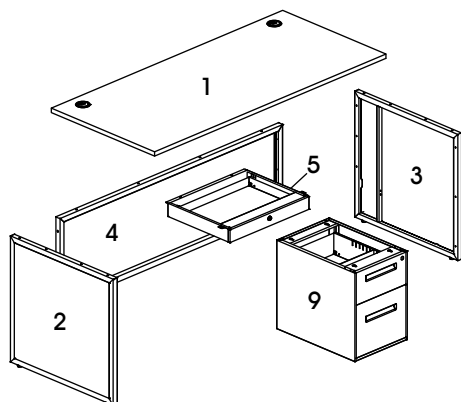

PIÈCES DU BUREAU

#	DESCRIPTION	QTÉ
1	Dessus de bureau de 66 x 30 po	1
2	Panneau latéral gauche de 30 po de largeur	1
3	Panneau latéral droit de 30 po de largeur	1
4	Panneau cache-jambes	1
5	Tiroir central	1
9	Classeur à caisson	1

PIÈCES DU RACCORD

#	DESCRIPTION	QTÉ
13	Dessus de bureau de raccord	1
14	Panneau cache-jambes de raccord	1

PIÈCES DU BAHUT

#	DESCRIPTION	QTÉ
4	Panneau cache-jambes	1
9	Classeur à caisson	1
10	Dessus de bahut de 66 x 24 po	1
11	Panneau latéral gauche de 24 po de largeur	1
12	Panneau latéral droit de 24 po de largeur	1

INSTRUCTIONS – BUREAU EN U



IMPORTANT! Montez le bureau sur une surface lisse qui ne marque pas afin d'éviter les rayures.

REMARQUE : Vérifiez que toutes les pièces sont incluses.

REMARQUE : Utilisez la clé Allen pour serrer les boulons.

REMARQUE : Utilisez le tournevis cruciforme pour serrer les vis.

REMARQUE : Les patins de nivellement et les capuchons pour passe-fil sont préinstallés.

MONTAGE DU BUREAU

1. Alignez le panneau cache-jambes (4) sur les trous du panneau latéral de 30 po (2). Fixez-le avec trois boulons M6 x 45 mm (B). Répétez la procédure pour l'autre panneau latéral. (Voir Figure 1)

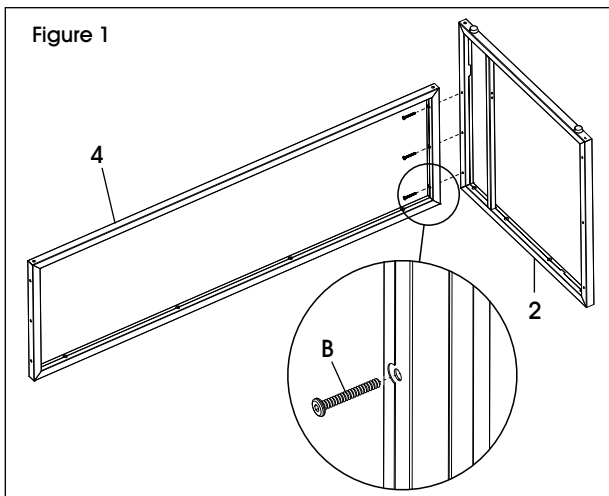

2. Placez le dessus de bureau de 66 x 30 po (1) à l'envers, avec les trous vers le haut. À deux, retournez le cadre du bureau assemblé. Fixez le cadre au dessus de bureau avec 12 boulons M6 x 45 mm (B). (Voir Figure 2)

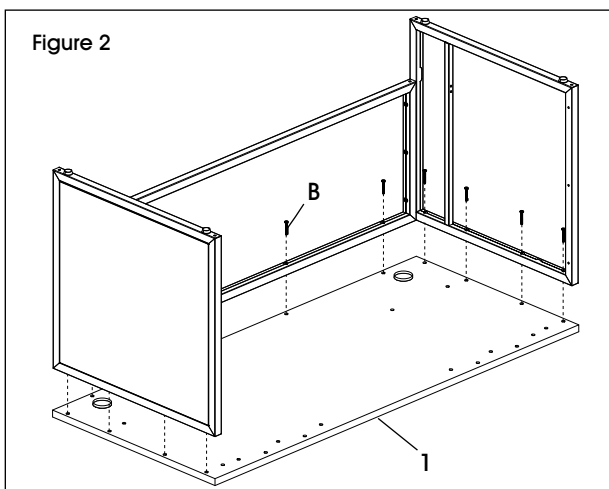

ARRÊT : Déterminez si le bureau en U sera configuré à droite ou à gauche. Le montage du bureau en U avec configuration à droite est indiqué dans les illustrations suivantes.

3. Insérez quatre vis à épaulement M6 x 14 mm (K) dans le dessus de bureau (1) et serrez-les avec le tournevis cruciforme. (Voir Figure 3)



REMARQUE : Pour une configuration de bureau en L à gauche, insérez les vis sur le côté opposé du bureau.



REMARQUE : Les vis à épaulement ne seront pas alignées avec le dessus de bureau. Les vis dépassent légèrement du dessus de bureau pour permettre le raccordement au classeur à caisson.

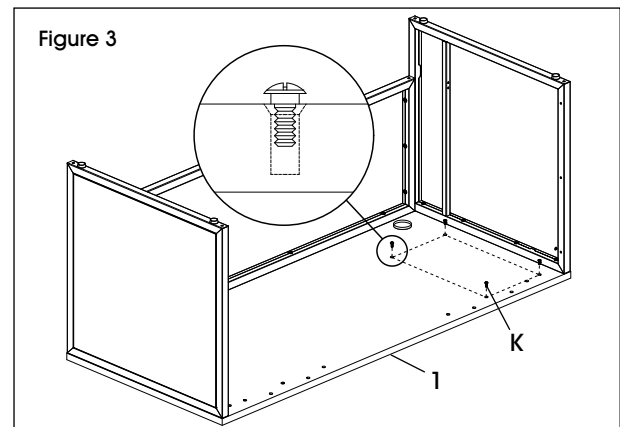

4. À deux, retournez le classeur à caisson (9). Abaissez soigneusement le classeur à caisson et alignez les onglets en trou de serrure du classeur à caisson sur les vis à épaulement (K) du dessus de bureau (1). (Voir Figure 4)



REMARQUE : Le classeur à caisson doit reposer sur le dessus de bureau et dépasser légèrement du bord avant.

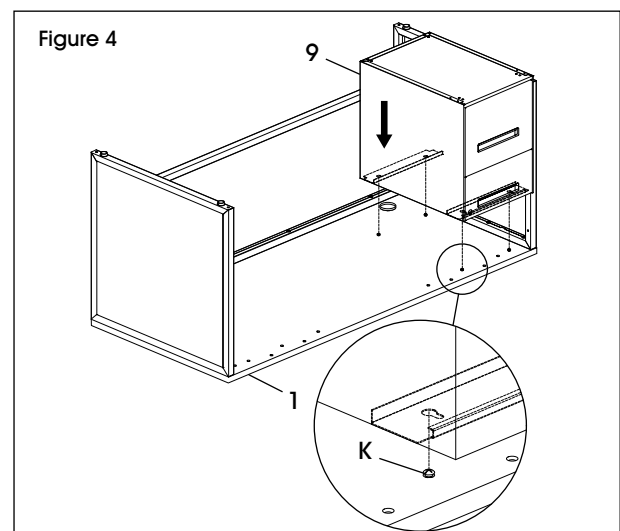

INSTRUCTIONS – BUREAU EN U – SUITE

5. Poussez le classeur à caisson (9) vers le panneau cache-jambes (4) pour accrocher les onglets en trou de serrure sur les vis à épaulement (K). (Voir Figure 5)

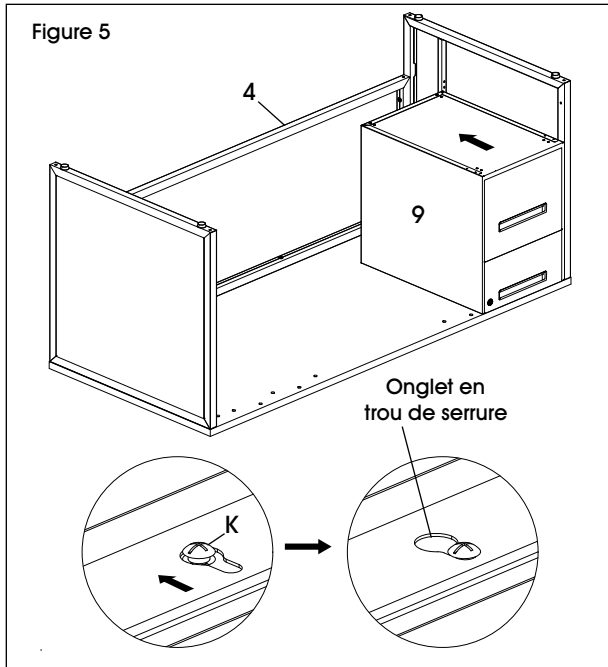

6. Fixez l'arrière du classeur à caisson (9) au panneau latéral avec le support en L gauche (I) et quatre boulons M6 x 15 mm (F). Répétez la procédure à l'avant du classeur à caisson avec le support en L droit (J) et quatre boulons M6 x 15 mm. (Voir Figure 6)

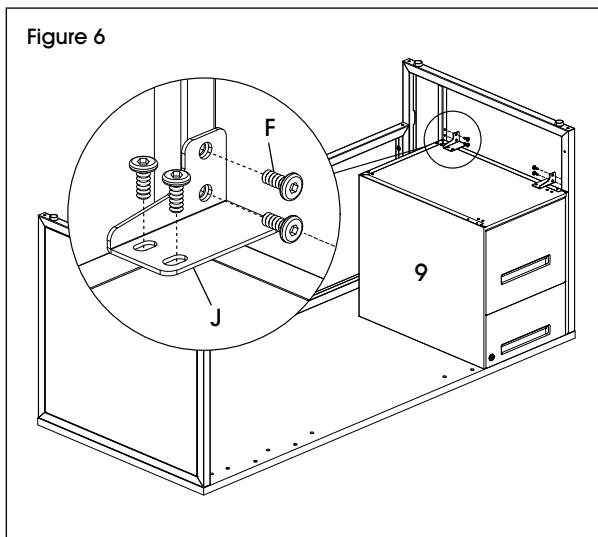

7. Placez le tiroir central (5) à l'envers à l'emplacement souhaité sur le dessus de bureau. Fixez-le avec quatre vis à bois ST 5 x 6 mm (D). (Voir Figure 7)



REMARQUE : Les trous préfiletés sur le dessus de bureau ne doivent pas être utilisés pour la fixation du tiroir.



REMARQUE : Les trous du tiroir peuvent être prépercés avec la perceuse (optionnel).



REMARQUE : Il est recommandé de positionner le tiroir au ras du bord avant du dessus de bureau.

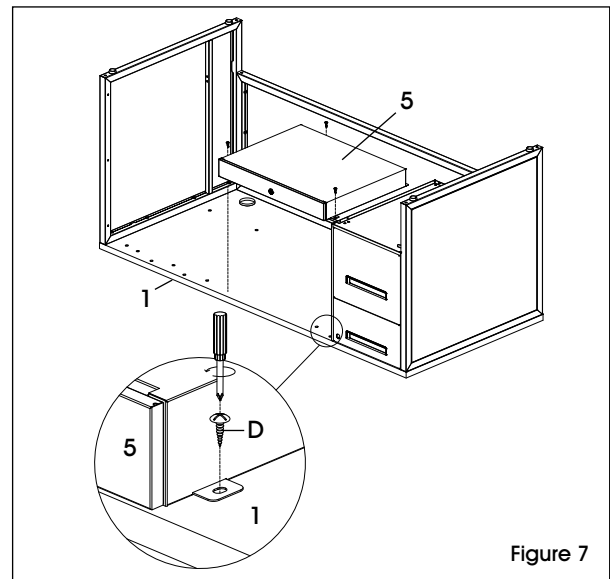

8. Fixez la plaque de connexion (G) au dessus de bureau (1) avec quatre boulons M6 x 15 mm (F). (Voir Figure 8)

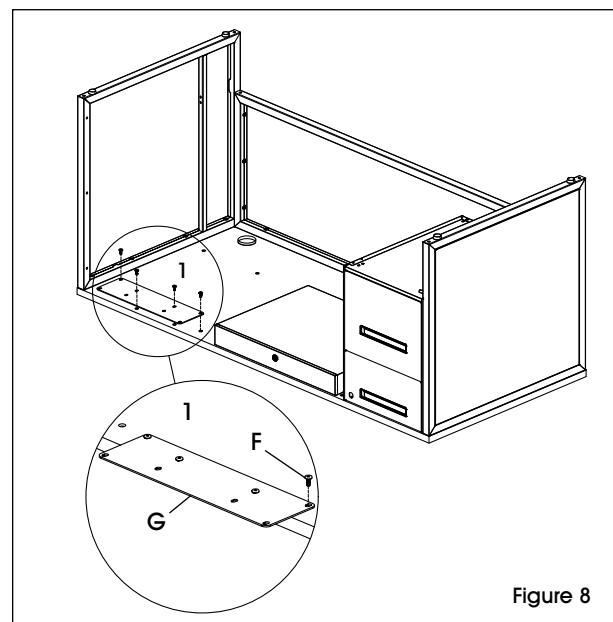

MONTAGE DU RACCORD

Fixez le panneau cache-jambes de raccord (14) sur le dessus de bureau du raccord (13) au moyen de quatre boulons M6 x 45 mm (B). (Voir Figure 9)

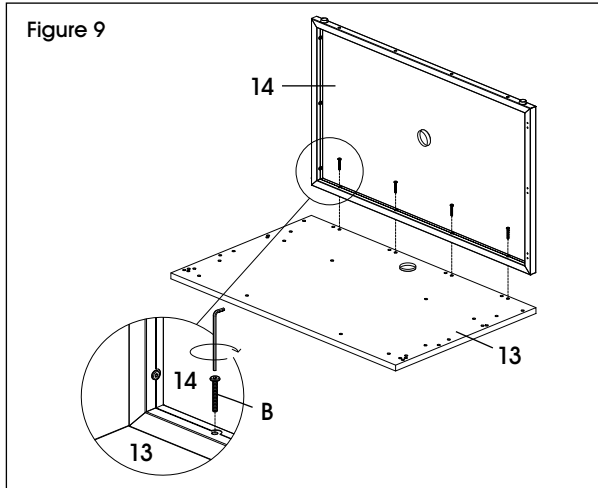

MONTAGE DU BAHUT

1. Alignez le panneau cache-jambes (4) sur les trous du panneau latéral gauche de 24 po (11). Fixez-le avec trois boulons M6 x 45 mm (B). Répétez la procédure pour le panneau droit de 24 po (12). (Voir Figure 10)

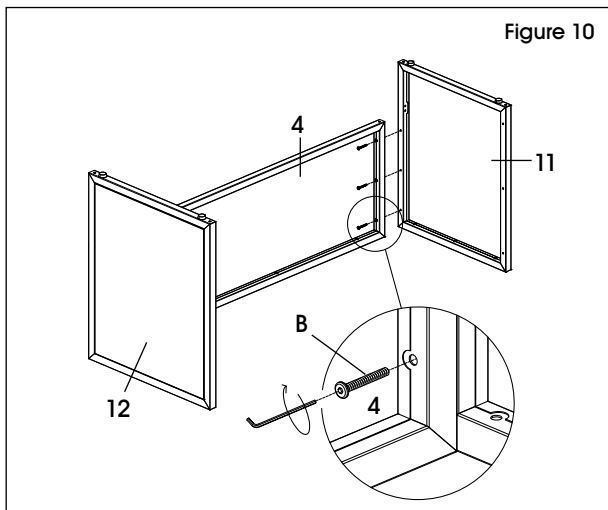

2. Placez le dessus du bahut de 66 x 24 po (10) à l'envers, avec les trous vers le haut. À deux, retournez le cadre du bahut monté et alignez-le sur les trous situés sur le dessus du bahut. Fixez-le avec 12 boulons M6 x 45 mm (B). (Voir Figure 11)

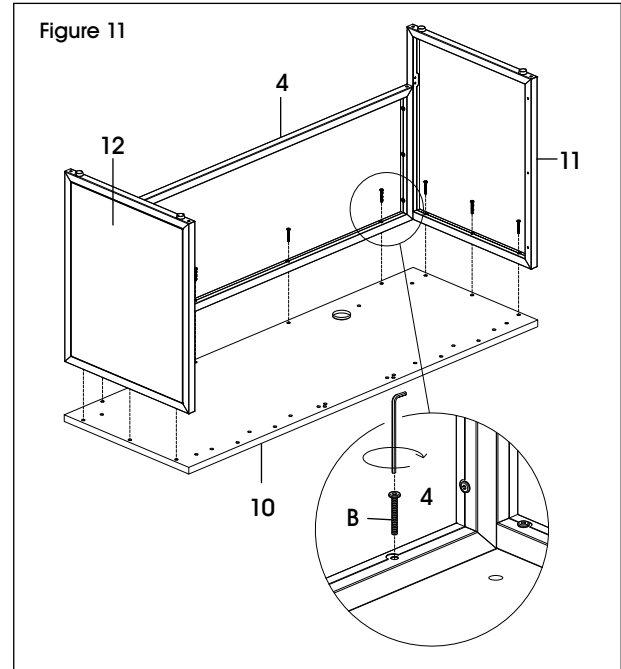

3. Insérez quatre vis à épaulement M6 x 14 mm (K) dans le dessus du bahut (10). (Voir Figure 12)

REMARQUE : Les vis à épaulement ne seront pas alignées avec le dessus de bureau. Les vis dépassent légèrement du dessus de bureau pour permettre le raccordement au classeur à caisson.

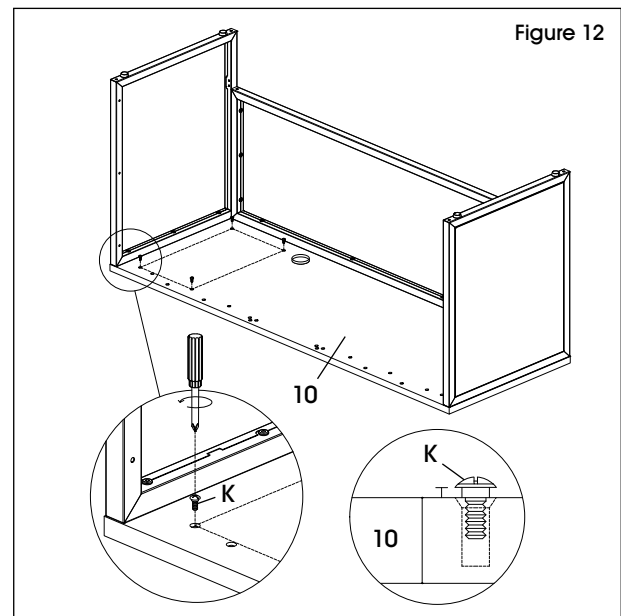

INSTRUCTIONS – BUREAU EN U – SUITE

4. À deux, retournez le classeur à caisson (9). Abaissez soigneusement le classeur à caisson et alignez les onglets en trou de serrure du classeur à caisson sur les vis à épaulement (K) du dessus de bahut (10). (Voir Figure 13)

 **REMARQUE :** Le classeur à caisson doit reposer sur le dessus de bahut et dépasser légèrement du bord avant.

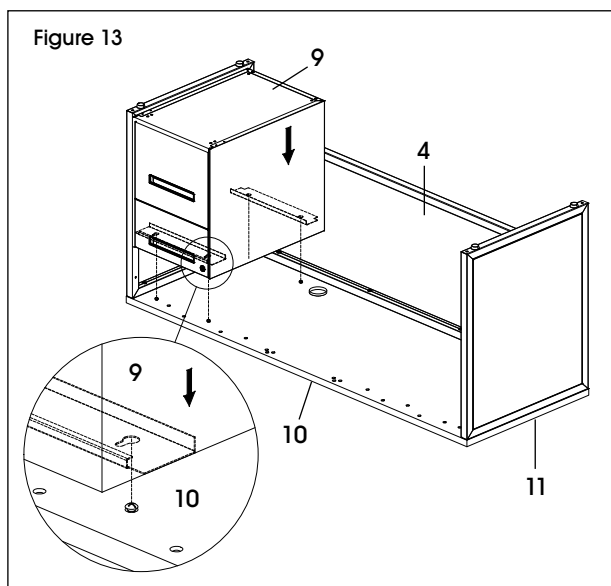

5. Poussez le classeur à caisson (9) vers le panneau cache-jambes (4) pour accrocher les onglets en trou de serrure sur les vis à épaulement (K). (Voir Figure 14)

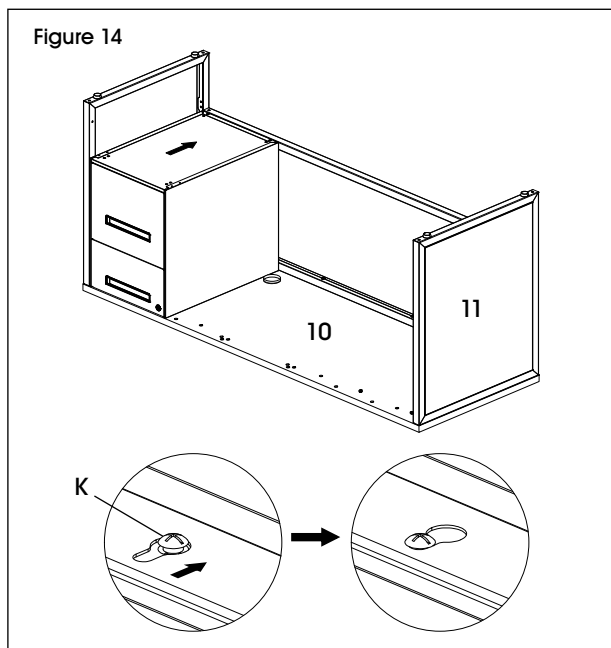

6. Fixez l'arrière du classeur à caisson (9) au panneau latéral avec le support en L droit (J) et quatre boulons M6 x 15 mm (F). Répétez la procédure à l'avant du classeur à caisson avec le support en L gauche (I) et quatre boulons M6 x 15 mm. (Voir Figure 15)

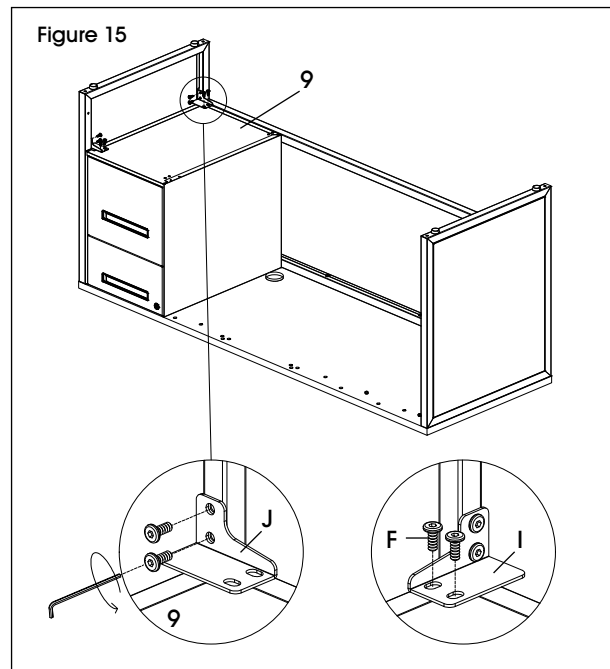

7. Fixez la plaque de connexion (G) au dessus de bahut (10) avec quatre boulons M6 x 15 mm (F). (Voir Figure 16)

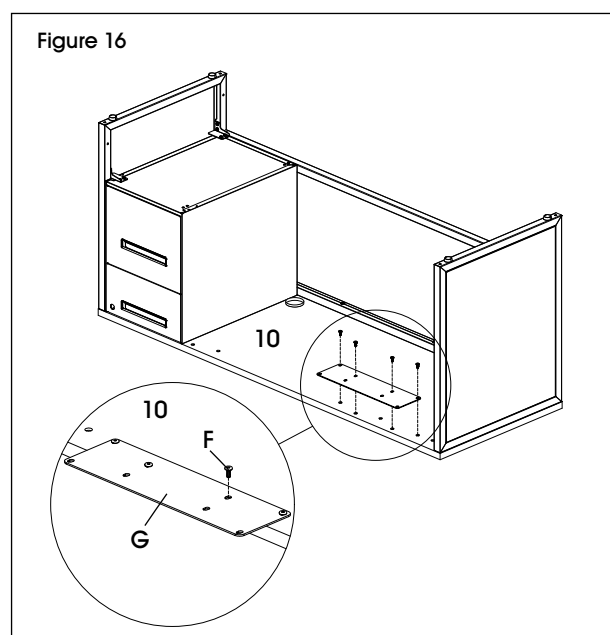

MONTAGE FINAL

 **REMARQUE :** Placez les éléments assemblés à proximité de l'endroit souhaité.

1. À deux, positionnez le bahut monté à la verticale. Fixez la plaque de connexion (G) du bahut au dessus de raccord (13) avec quatre boulons M6 x 15 mm (F). (Voir Figure 17)

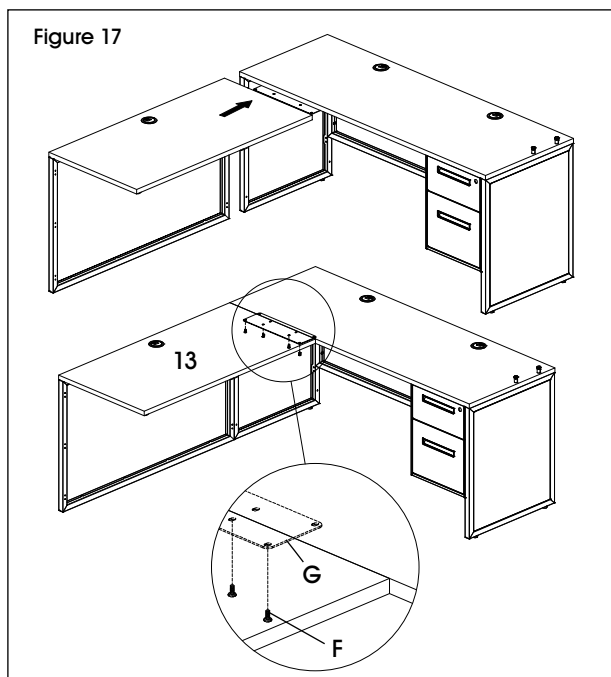

2. Fixez un support en I (H) au panneau cache-jambes du raccord et au panneau latéral adjacent du bahut avec trois boulons M6 x 15 mm (F) pour les maintenir ensemble. Répétez la procédure pour les deux autres supports en I. (Voir Figure 18)

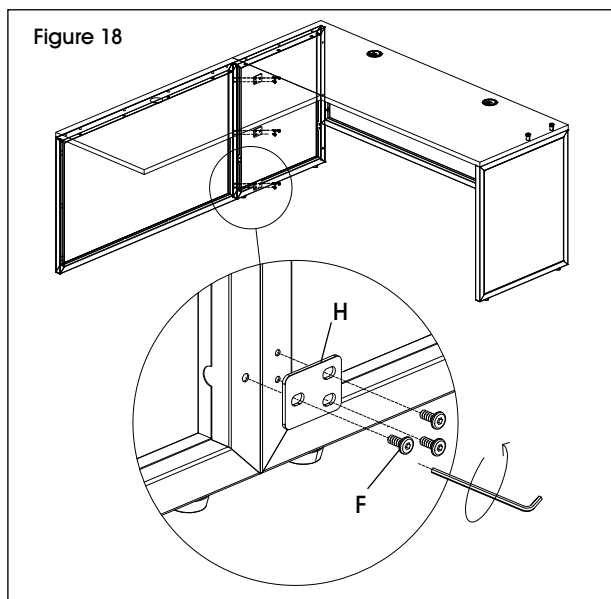

3. À deux, retournez le bureau monté et placez-le à côté du raccord. Fixez la plaque de connexion (G) au dessus du raccord (13) avec quatre boulons M6 x 15 mm (F). (Voir Figure 19)

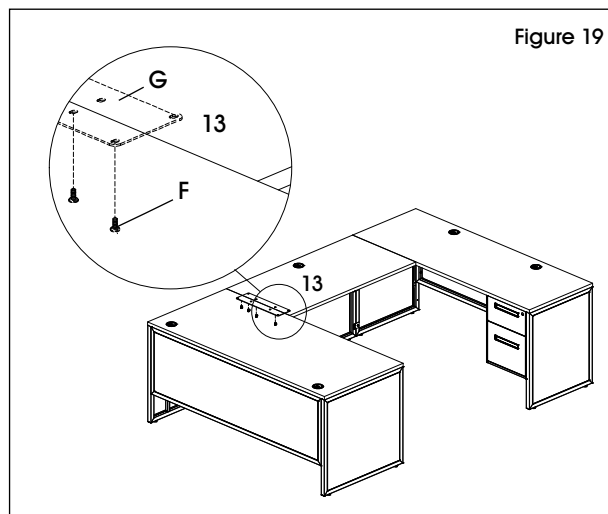

4. Fixez le raccord au panneau cache-jambes (14) et au panneau latéral adjacent du bureau à l'aide d'un support en I (H) et de trois boulons M6 x 15 mm (F). Répétez la procédure pour les deux autres supports en I. (Voir Figure 20)

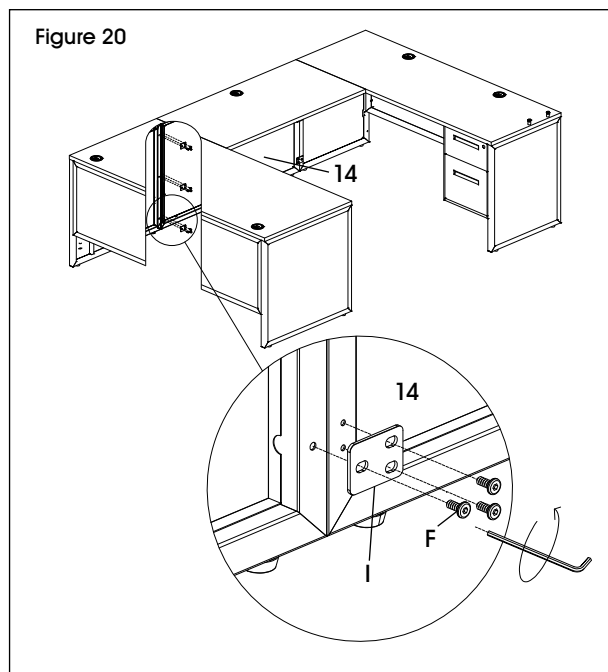

 **ARRÊT!** Si vous montez la huche, passez à la page suivante. Sinon, le montage est terminé.

MATÉRIEL DE FIXATION DE LA HUCHE

B

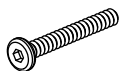

Boulon M6 x 45 mm
x 36

F



Boulon M6 x 15 mm
x 32

M

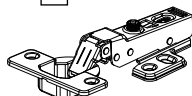

Charnière x 4

N



Vis à charnière
ST 3.5 x 14 mm x 8

O



Boulon à charnière
M4 x 10 mm x 8

P

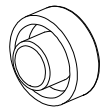

Roue de porte x 4

Q

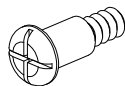

Boulon de porte
M6 x 14 mm x 4

R

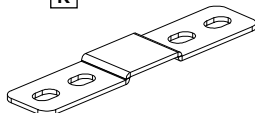

Support de huche x 2

S

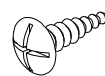

Vis à bois ST 4 x 18 mm
x 4

T

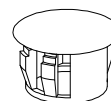

Capuchon en plastique
x 4

Ensemble serrure et clés x 2

U



Vis x 1

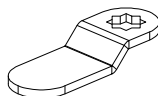

Plaque de serrure x 1

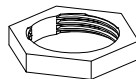

Écrou hexagonal x 1

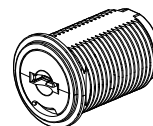

Barillet x 1

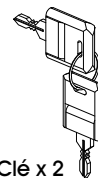

Clé x 2

PIÈCES DE LA HUCHE

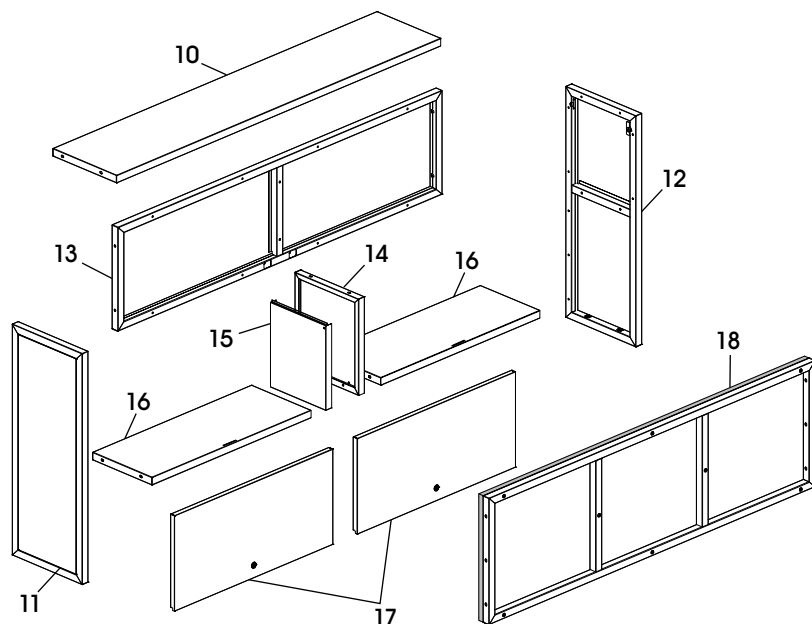

PIÈCES DE LA HUCHE

#	DESCRIPTION	QTÉ
10	Panneau supérieur	1
11	Panneau latéral gauche	1
12	Panneau latéral droit	1
13	Panneau arrière	1
14	Panneau de séparation extérieur	1
15	Panneau de séparation intérieur	1
16	Panneau inférieur	2
17	Porte	2
18	Panneau d'affichage	1

MONTAGE

1. Placez le panneau supérieur (10) à l'envers. Alignez le panneau arrière (13) sur les trous du panneau supérieur. Serrez légèrement quatre boulons M6 x 15 mm (F). (Voir Figure 21)

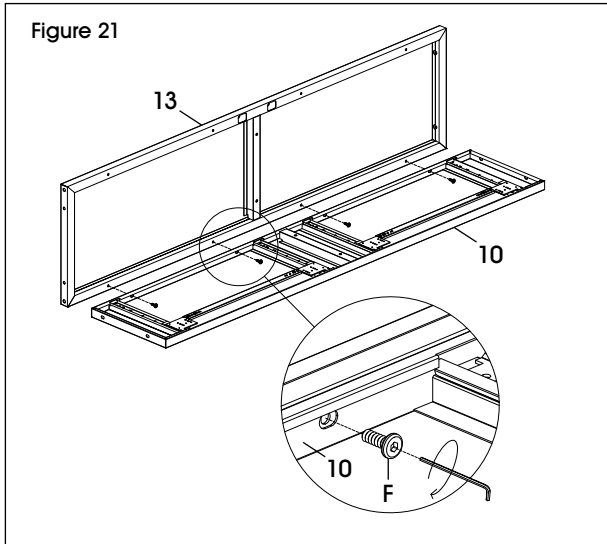

2. Insérez partiellement deux boulons M6 x 15 mm (F) dans le panneau latéral gauche (11). Laissez un espace d'environ 1/8 po entre les têtes de boulons et le panneau. Alignez les boulons du panneau latéral gauche avec les onglets en trou de serrure du panneau supérieur (10). Insérez les deux boulons dans les onglets en trou de serrure. Tirez le panneau latéral gauche vers l'avant du panneau supérieur pour verrouiller les boulons dans les onglets en trou de serrure. Serrez les boulons complètement. Répétez la procédure pour le panneau latéral droit (12). (Voir Figure 22)

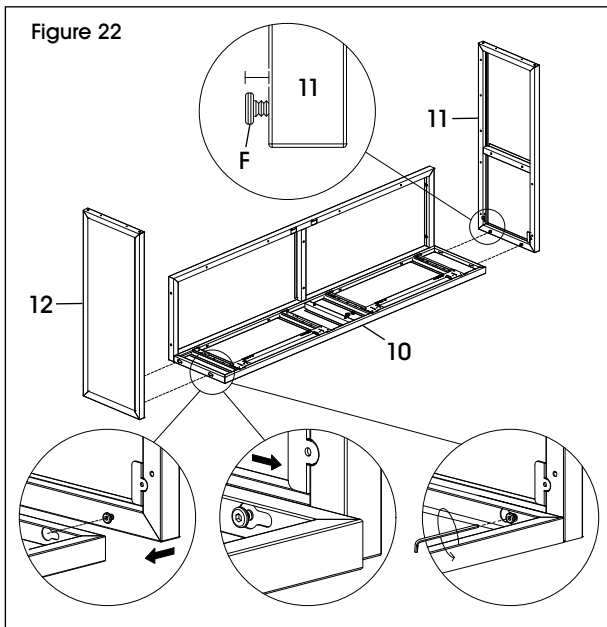

3. Insérez deux boulons M6 x 45 mm (B) pour fixer le panneau latéral gauche (11) au panneau arrière (13). Serrez-les, puis répétez la procédure pour le panneau latéral droit (12). Serrez complètement les quatre boulons M6 x 15 mm de l'étape 1 dans le panneau supérieur (10). (Voir Figure 23)

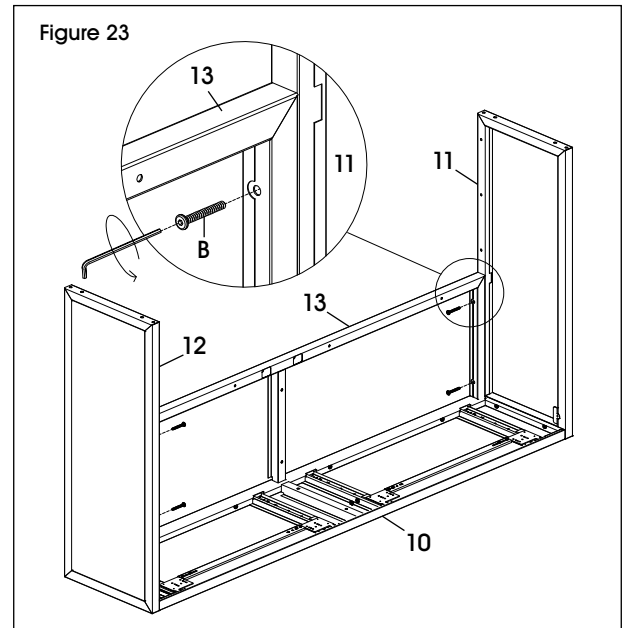

4. Placez un panneau de séparation extérieur (14) au centre de la huche et alignez-le sur les trous du panneau supérieur (10) et du panneau arrière (13). Fixez-le avec quatre boulons M6 x 15 mm (F). (Voir Figure 24)

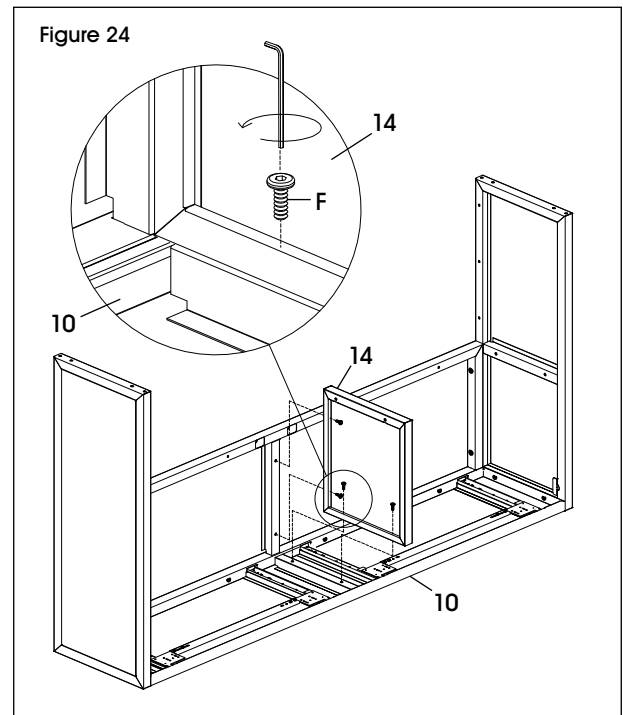

INSTRUCTIONS – HUCHE – SUITE

5. Placez le panneau de séparation intérieur (15) dans le panneau de séparation extérieur (14). Fixez-le en place en le tapotant doucement avec un maillet en caoutchouc. Veillez à ce que les bords des panneaux de séparation soient bien alignés. (Voir Figure 25)

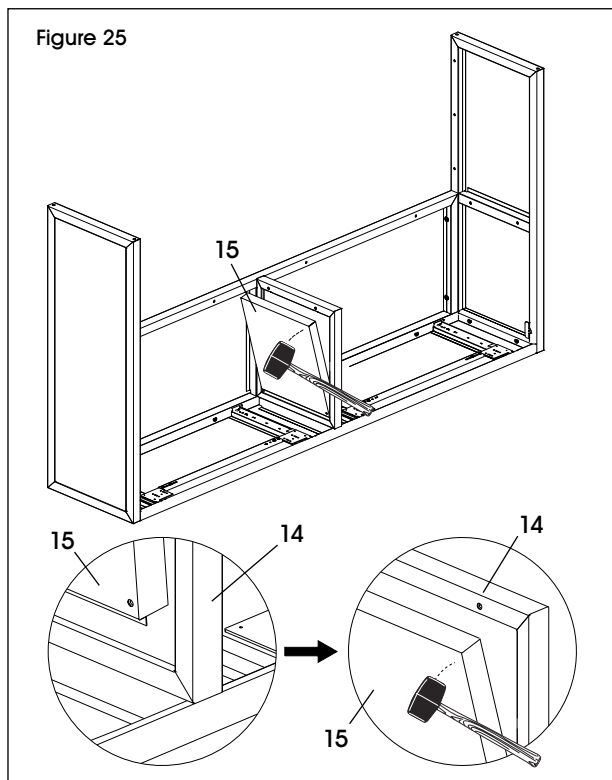

6. Alignez les panneaux intérieurs (16) sur les trous des panneaux latéraux, du panneau arrière (13) et du panneau de séparation extérieur (14). (Voir Figure 26)

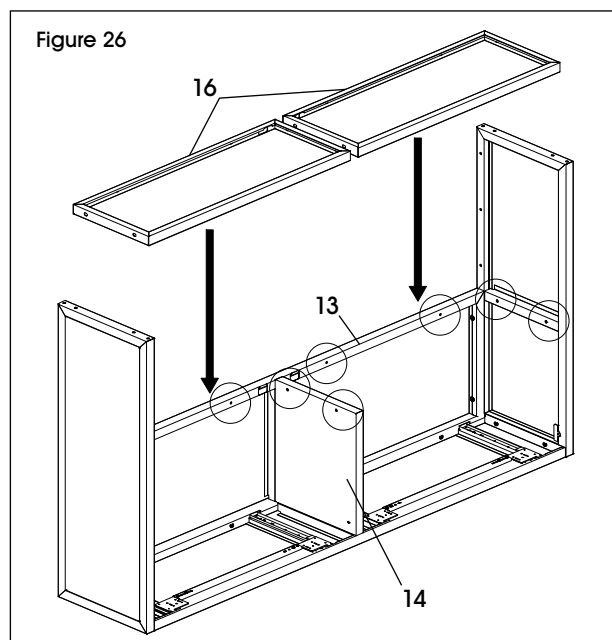

7. Fixez les panneaux intérieurs (16) avec 12 boulons M6 x 15 mm (F). (Voir Figure 27)

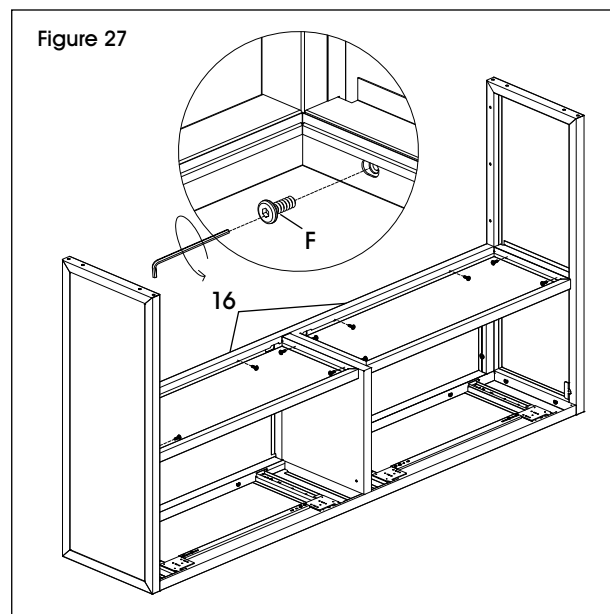

8. Fixez les roues de portes (P) à l'intérieur de la huche avec quatre boulons de porte M6 x 14 mm (Q). (Voir Figure 28)

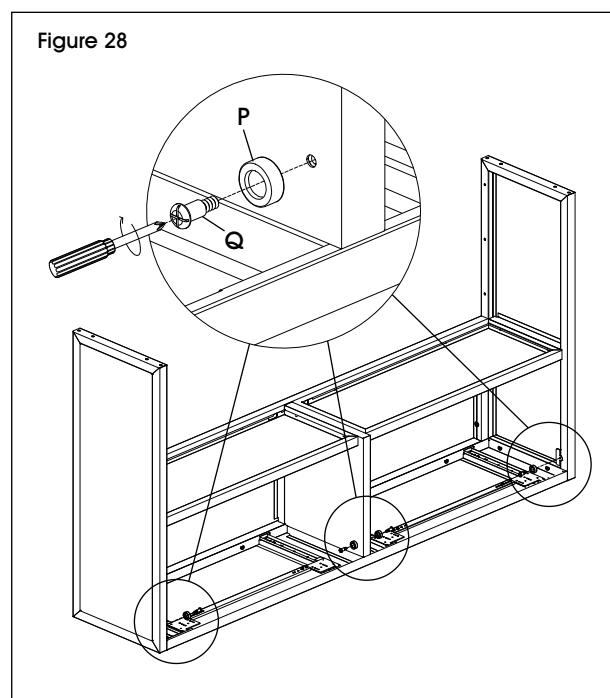

INSTRUCTIONS – HUCHE – SUITE

9. Fixez les charnières (M) aux portes (17) avec huit vis à charnière ST 3.5 x 14 mm (N). (Voir Figure 29)

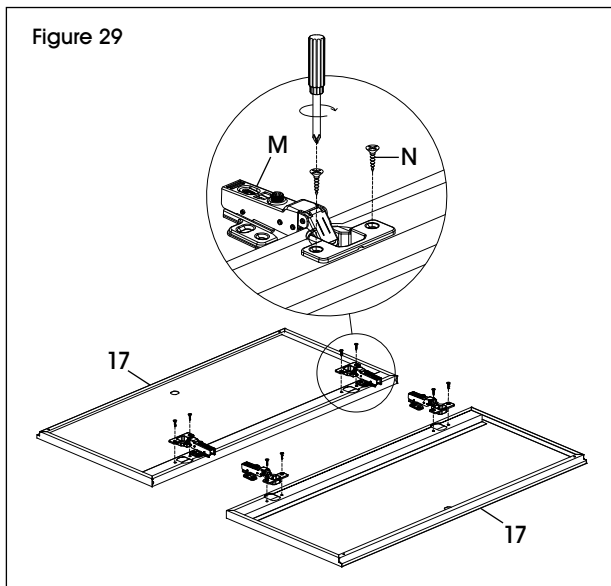

10. Retirez la plaque de serrure et l'écrou hexagonal du barillet (U). Insérez le barillet dans le trou de la porte et serrez l'écrou hexagonal autour du barillet (U). Alignez la plaque de la serrure sur l'extrémité du barillet et fixez-la avec une vis (U). Répétez l'opération pour l'autre porte. (Voir Figure 30)



IMPORTANT! Veillez à ce que les plaques de serrure soient orientées vers le bas lorsqu'en position « verrouillé » et orientées vers le haut lorsqu'en position « déverrouillé ».

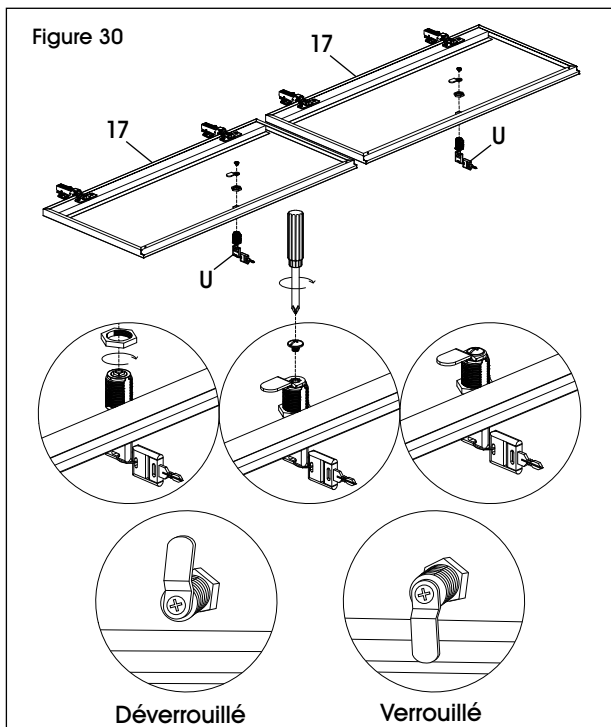

11. Alignez la charnière (M) sur les trous du panneau supérieur (10). Fixez-la avec deux boulons à charnière M4 x 10 mm (O). Répétez la procédure pour les trois autres charnières. (Voir Figure 31)

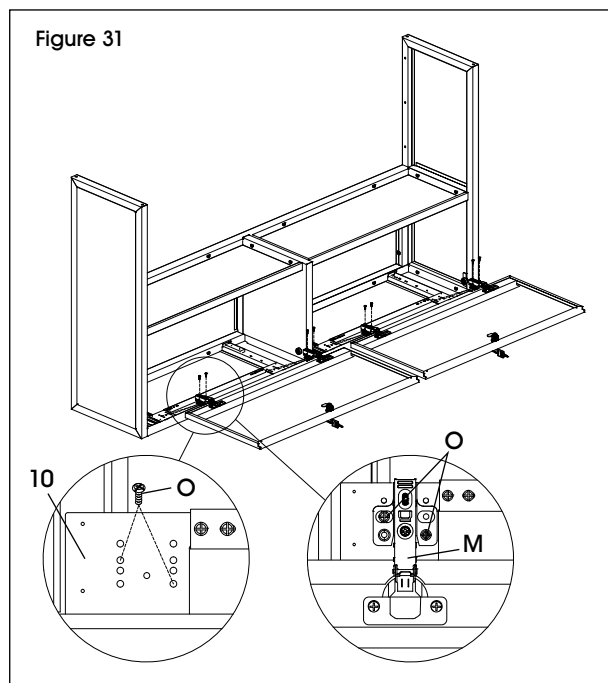

12. Ajustez les charnières pour aligner correctement les portes. (Voir Figure 32)

- **Angle de porte :** Desserrez les vis latérales des charnières, faites glisser la porte vers la gauche ou la droite, puis serrez la vis pour la fixer.
- **Profondeur de porte :** Desserrez la vis arrière de la charnière, faites glisser la porte vers l'avant ou l'arrière, puis serrez la vis pour la fixer.
- **Hauteur de porte :** Serrez la vis centrale pour abaisser la porte, ou desserrez la vis centrale pour l'élever.

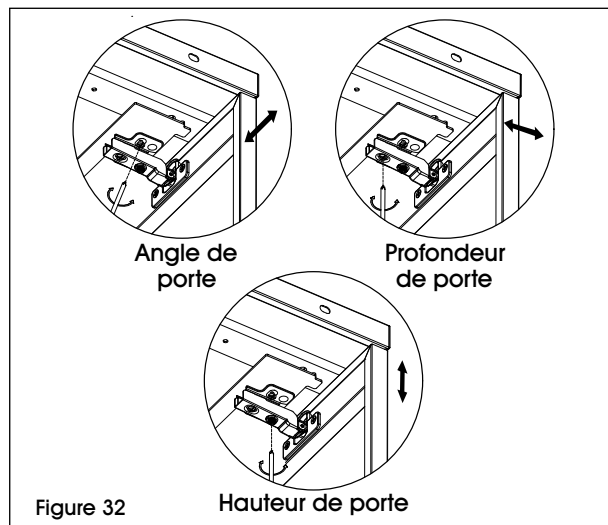

INSTRUCTIONS – HUCHE – SUITE



Si vous fixez le panneau d'affichage Uline H-10813, passez à l'étape 13. Sinon, passez à l'étape 14.

13. Alignez le panneau d'affichage (18) sur les trous des panneaux latéraux. Fixez-le avec six boulons M6 x 45 mm (B). (Voir Figure 33)

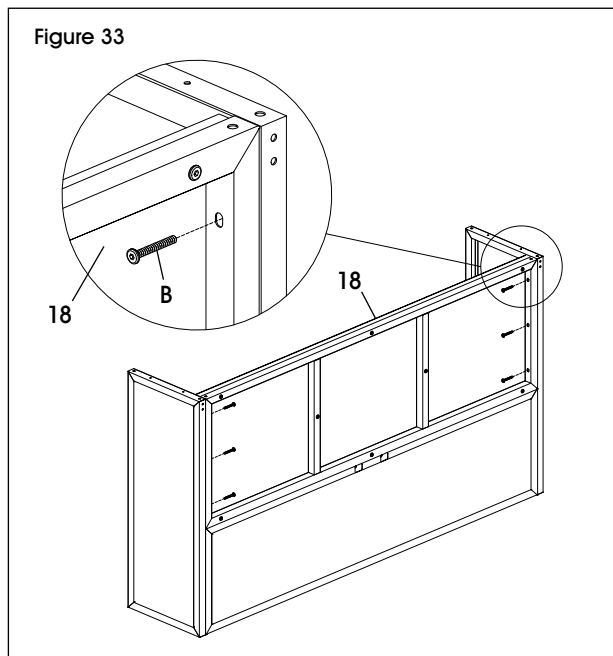

REMARQUE : Au besoin, tapez sur le panneau d'affichage avec un maillet en caoutchouc pour le positionner entre les panneaux latéraux.

14. À deux, mettez la huche à l'endroit. Placez la huche avec précaution sur le dessus de bureau (1) en l'alignant avec la partie arrière du bahut. Fixez les supports de huche (R) aux panneaux latéraux du bahut et aux panneaux latéraux de la huche avec huit boulons M6 x 15 mm (F). (Voir Figure 34)

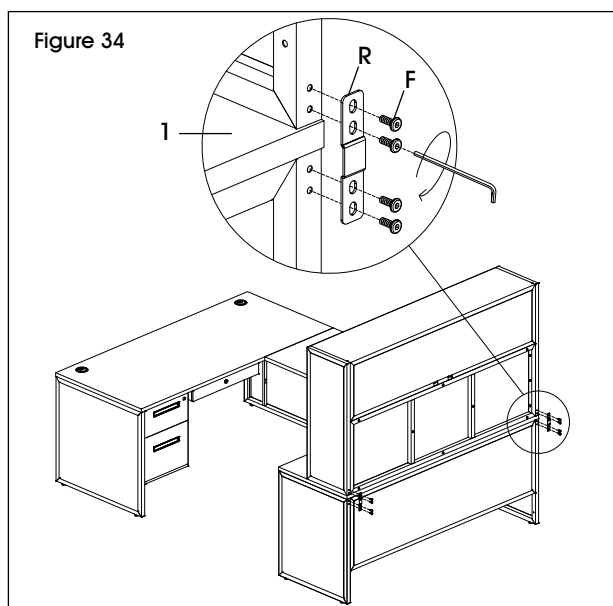

15. Fixez la huche à l'aide de quatre vis ST4 x 18 mm (S) à travers les trous des panneaux latéraux de la huche et dans le dessus de bureau. Serrez-les avec un tournevis cruciforme. (Voir Figure 35)

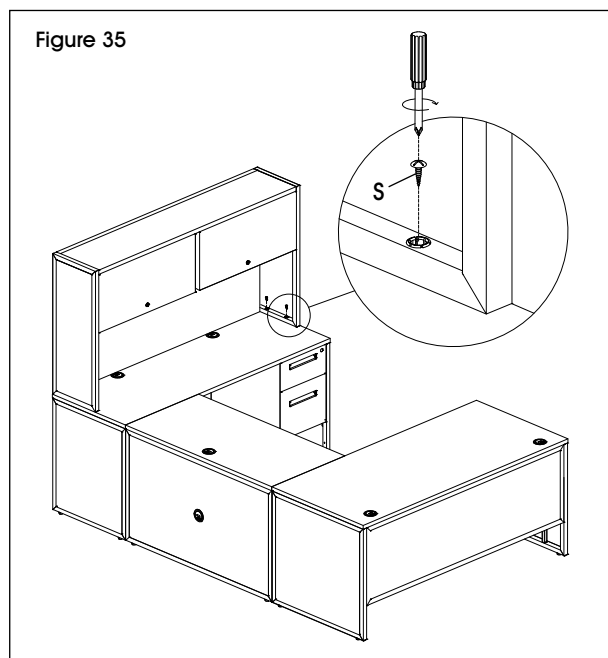

16. Insérez les capuchons en plastique (T) dans les trous de vis à l'intérieur des panneaux latéraux de la huche. Le montage est terminé. (Voir Figure 36)



REMARQUE : Si vous fixez une lumière, passez à la page suivante. Sinon, le montage est terminé.

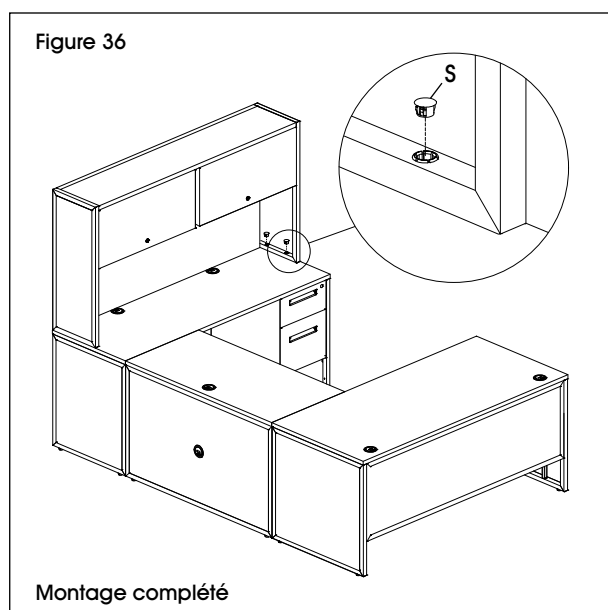

INSTALLATION – LUMIÈRE

Il est possible de fixer une lumière à DEL magnétique (n° de modèle Uline H-7162) sous chacune des armoires à suspendre avec les aimants de fixation intégrés.

1. Alignez la lumière sous l'armoire à suspendre et les aimants serviront à la maintenir en place. (Voir Figure 37)

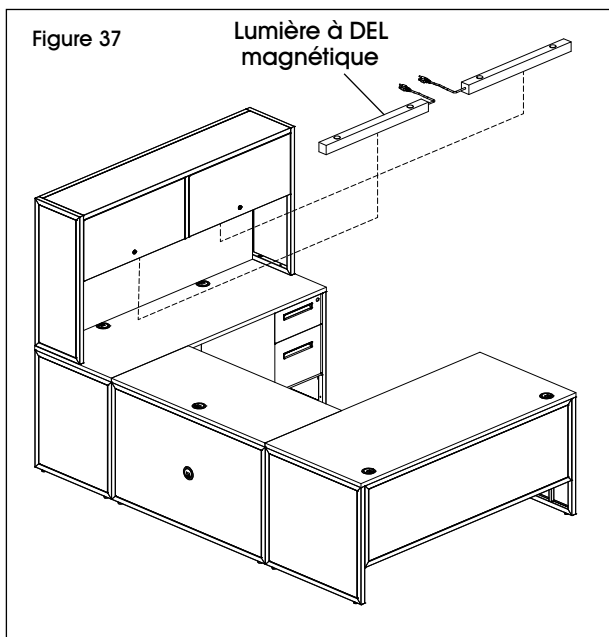

2. Faites passer les extrémités des prises dans les ouvertures situées à l'arrière de la huche. (Voir Figure 38)

