

ULINE H-9752, H-9753

DOWNTOWN COLLECTION

1-800-295-5510
uline.com

RECEPTION DESK

TOOLS NEEDED



Three Person Assembly
Recommended

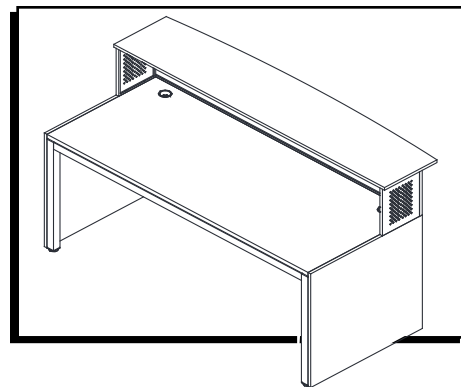

RECEPTION DESK PARTS



M6 x 12 mm Bolt x 31

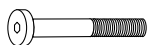

M6 x 65 mm Bolt x 10



L-Bracket x 7



Camlock Pin x 6

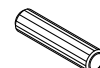

Dowel x 4



Camlock x 6

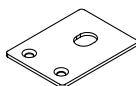

Base Bracket x 2



M4 x 16 mm Screw x 4



M6 x 15 mm Bolt x 8



72.5" Foam Strip x 1



10.25" Foam Strip x 2



11.75" Foam Strip x 6

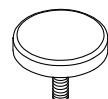

Floor Glide x 4



Black Grommet Cap
x 2



Silver Grommet Cap
x 2

DESK ASSEMBLY



NOTE: Assemble on smooth, non-marring surface to avoid scratching.

- Use Allen wrench to tighten bolts.
- Use Phillips screwdriver to tighten camlock pins, camlocks and screws.
- Check that all parts are included.

1. Fit support rail over corresponding bracket on leg. Use four M6 x 12 mm bolts to secure each side of support rail. Repeat for remaining support rail. (See Figure 1)



To continue desk assembly (H-9752), proceed to step 2 below.



To continue L-Desk assembly (H-9753), proceed to L-Desk Assembly on page 4.

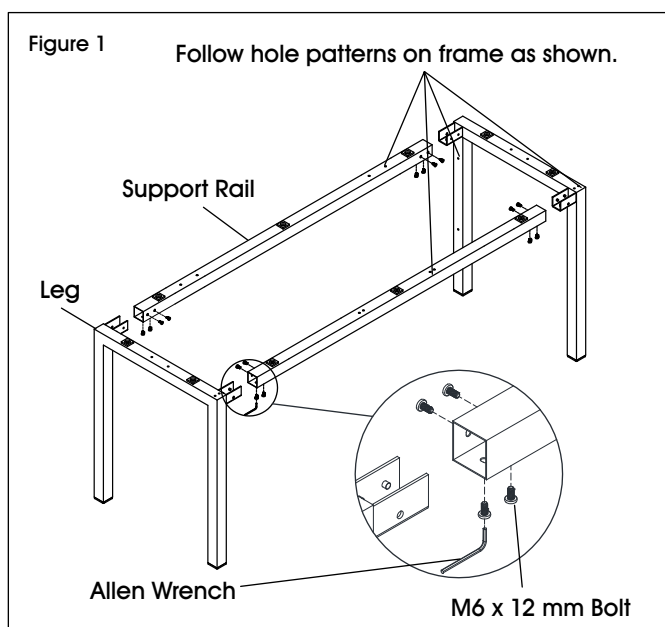

DESK ASSEMBLY CONTINUED

- Place desktop panel upside down with holes facing up. With second person, turn assembled frame upside down. Use 10 M6 x 65 mm bolts (included with reception desk shell) to secure frame to desktop, incorporating seven L-Brackets along the rear and sides of frame. (See Figure 2)

 **NOTE: Do not tighten bolts until step 6 is complete.**

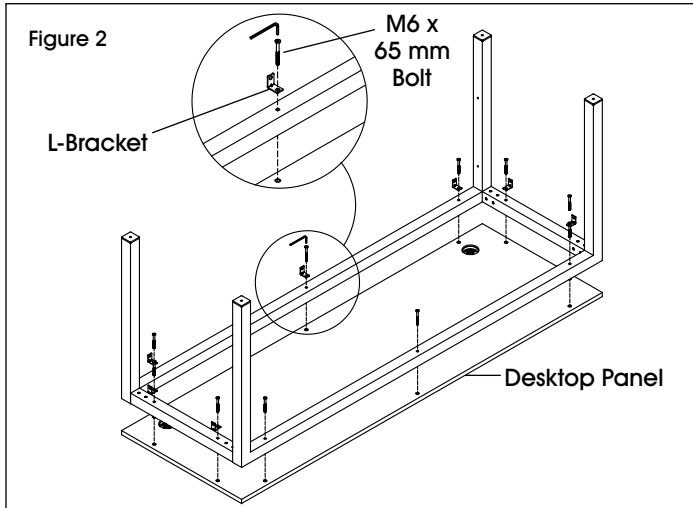

- Set assembled desk aside. Install six camlock pins and insert four dowels in leg panels (2 and 3). Insert six camlocks into corresponding holes in modesty panel (1). (See Figure 3)
- Fit leg panels (2 and 3) together with modesty panel (1) and turn each camlock clockwise until it locks. (See Figure 3)



IMPORTANT! The arrow on the camlock must point toward the camlock pin for proper alignment. Turn camlock clockwise 1/4 turn to lock. (See Figure 3)

IMPORTANT: Function of Cam

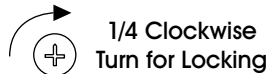

Make sure the arrow is pointing upwards before inserting into the panel's hole.

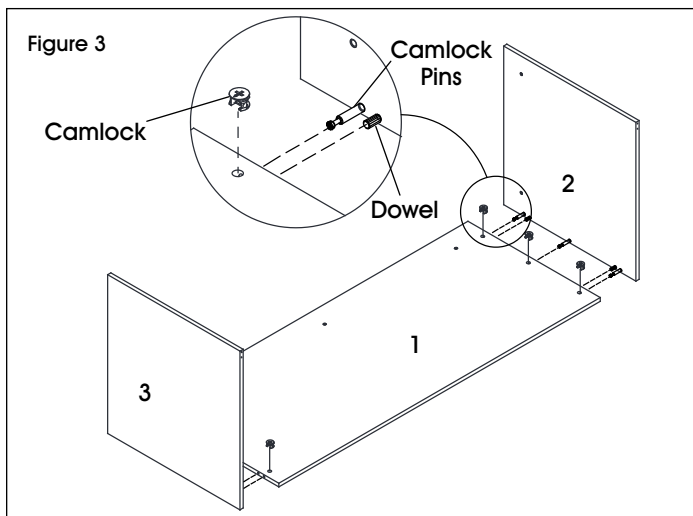

- Place assembled panels around the outside of assembled frame with modesty panel on the same side as grommet holes. (See Figure 4)

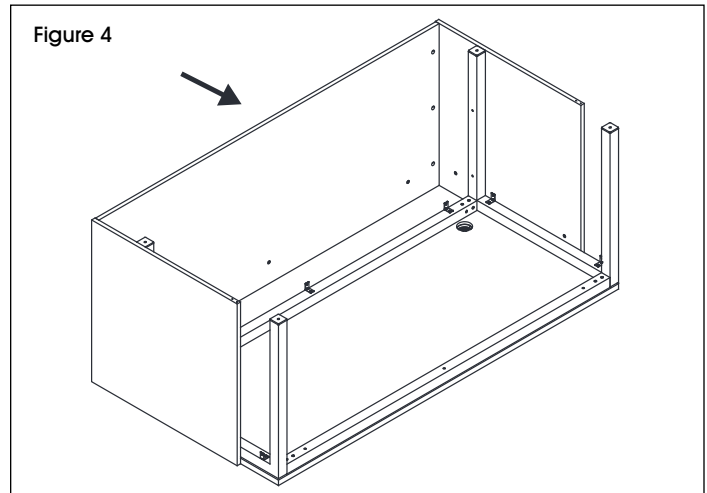

- Use seven M6 x 12 mm bolts to secure shell to L-Brackets. Tighten all M6 x 65 bolts from step 2 using Allen wrench. (See Figure 5)

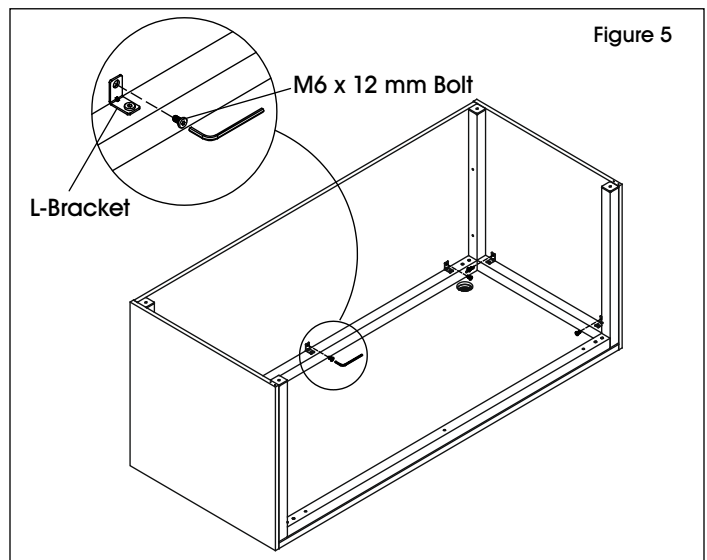

DESK ASSEMBLY CONTINUED

7. Attach two base brackets to legs opposite of modesty panel with four M4 x 16 mm screws. (See Figure 6)

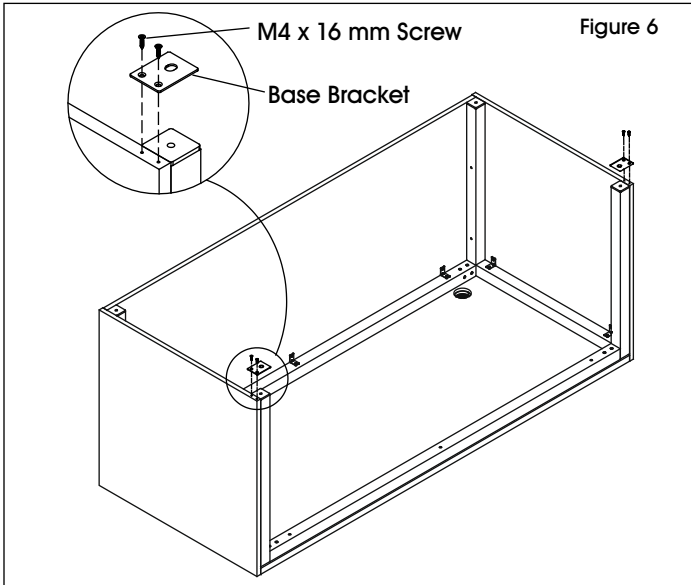

8. Insert floor glides into legs. (See Figure 7)

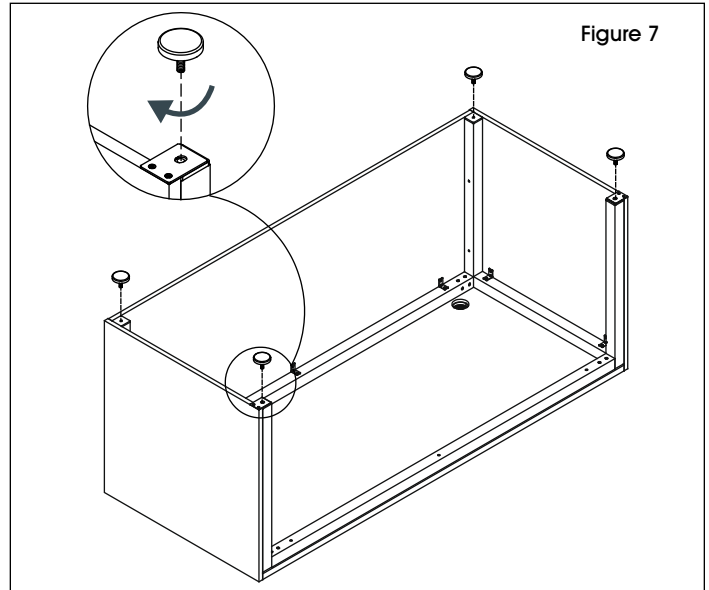

9. With second person, set desk upright. Adjust floor glides to compensate for uneven floors.



To finish desk assembly, proceed to Transaction Counter assembly on page 6.

RECEPTION L-DESK PARTS



M6 x 12 mm Bolt x 12

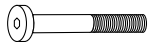

M6 x 65 mm Bolt x 6



L-Bracket x 4

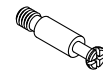

Camlock Pin x 3



Dowel x 2



Camlock x 3



M4 x 16 mm Screw x 4



M6 x 15 mm Bolt x 4

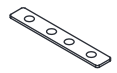

Connector Bracket x 1



Large Camlock Cap x 3



Small Camlock Cap x 2

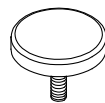

Floor Glide x 2



Black Grommet Cap x 1



Silver Grommet Cap x 1

L-DESK ASSEMBLY



NOTE: Parts for L-Desk are included in Reception Desk parts list on page 1 and Reception L-Desk parts list on page 3.

1. Assemble L-Desk. Fit support rail over corresponding bracket on leg. Use four M6 x 12 mm bolts to secure. Repeat for remaining support rail. (See Figure 8)

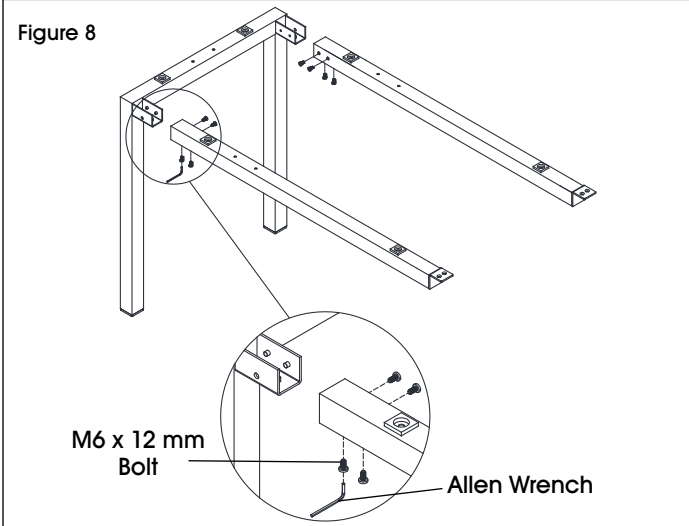

2. Position assembled L-Desk frame over holes in assembled desk shell. Use four M6 x 15 mm bolts to secure. (See Figure 9)



NOTE: Figure 9 shows left-hand configuration. For right-hand configuration, attach L-Desk return to opposite side of assembled desk frame.

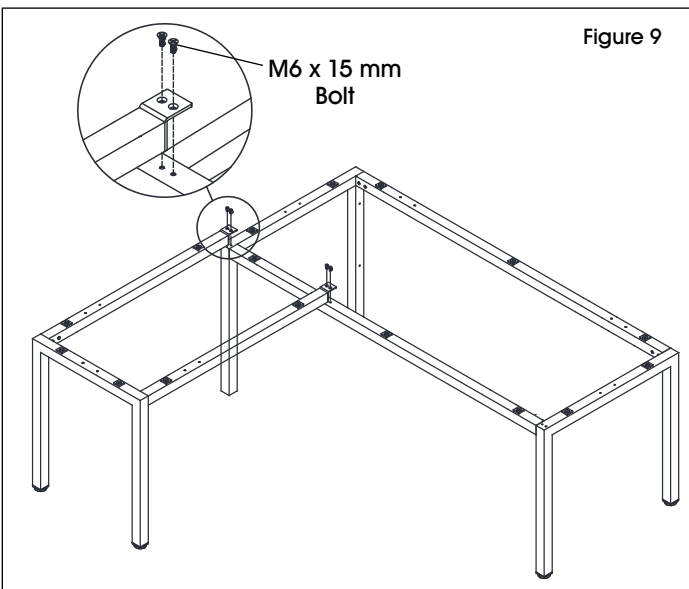

3. Place desktop panels upside down with holes facing up. With two or three people, turn over assembled L-Desk frame. Use 16 M6 x 65 mm bolts (included with reception desk shell and reception return shell) to secure to desktop panels, incorporating 11 L-Brackets along the rear and sides of frame. (See Figure 10)

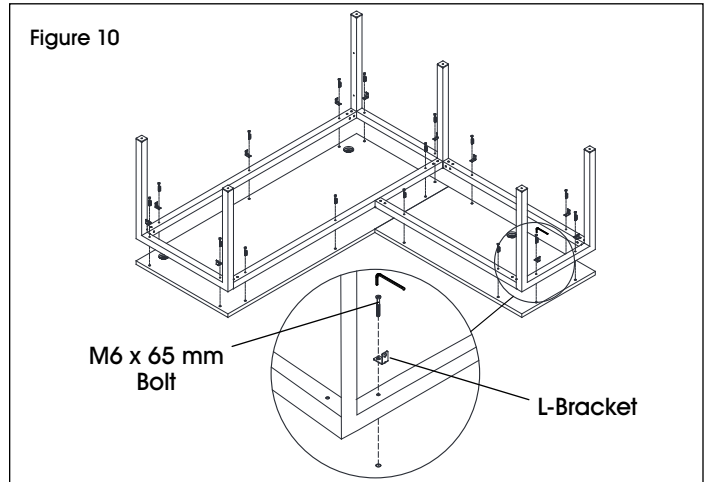

4. Set assembled L-Desk aside. Install six camlock pins and insert four dowels in leg panels (2 and 3). Insert six camlocks into corresponding holes in modesty panel (1). (See Figure 11)
5. Fit leg panels (2 and 3) together with modesty panel (1) and turn each camlock clockwise until it locks. (See Figure 11)



IMPORTANT! The arrow on the camlock must point toward the camlock pin for proper alignment. Turn camlock

clockwise 1/4 turn to lock. (See Figure 11)

IMPORTANT: Function of Cam

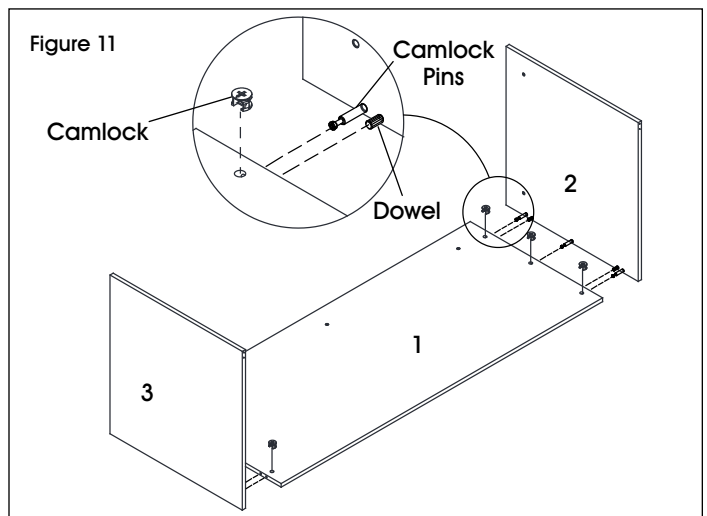
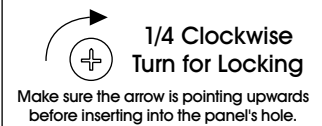

L-DESK ASSEMBLY CONTINUED

6. Place assembled panels around the outside of assembled L-Desk frame with modesty panel on the same side as grommet holes. (See Figure 12)

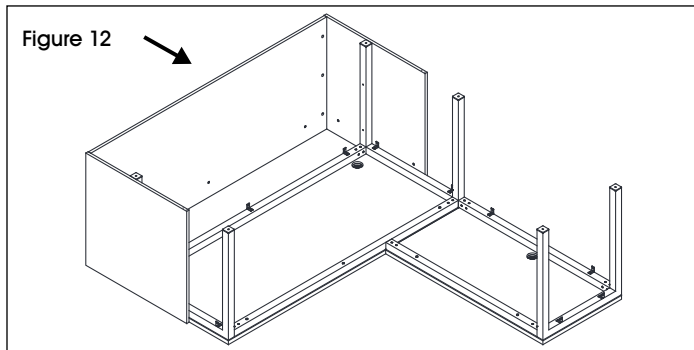

7. Use seven M6 x 12 mm bolts to secure desk shell to L-Brackets. (See Figure 13)

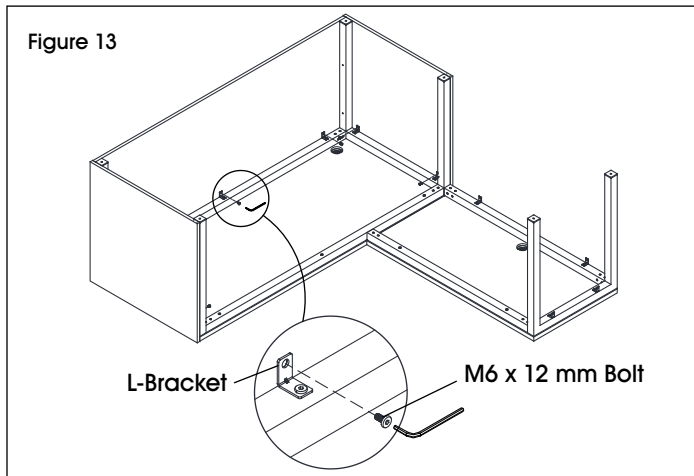

8. Install three camlock pins and insert two dowels in leg panel (4). Insert three camlocks into corresponding holes in L-Desk return modesty panel (5). (See Figure 14)
9. Fit leg panel (4) together with modesty panel (5) and turn each camlock clockwise until it locks. (See Figure 14)

 **NOTE:** Figure 14 shows left-hand configuration. For right-hand configuration, attach leg panel to opposite side of modesty panel.

 **NOTE:** Camlock caps are decorative. You may install after assembly is complete.

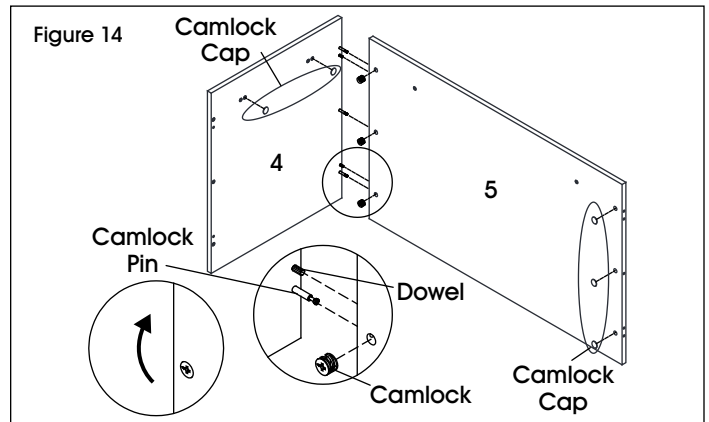

10. Place assembled L-Desk panels around the outside of assembled L-Desk frame with modesty panel on the same side as grommet hole. (See Figure 15)

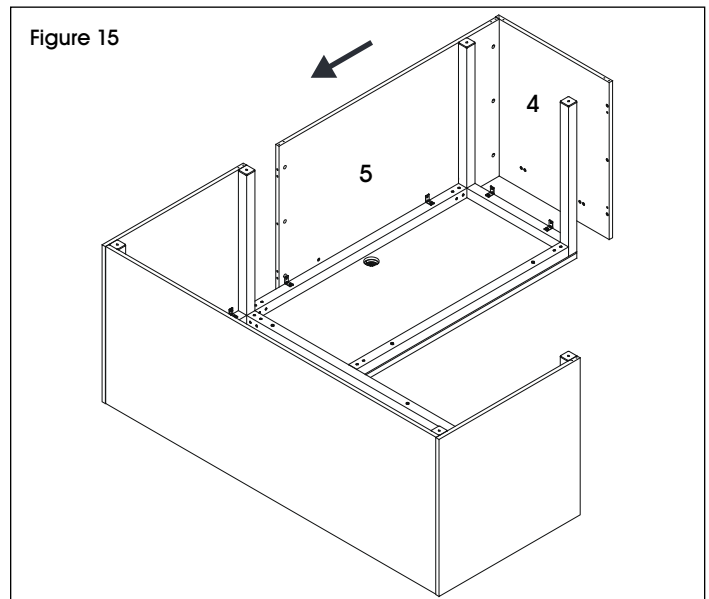

L-DESK ASSEMBLY CONTINUED

11. Use four M6 x 12 mm bolts to secure panels to L-Brackets. (See Figure 16)

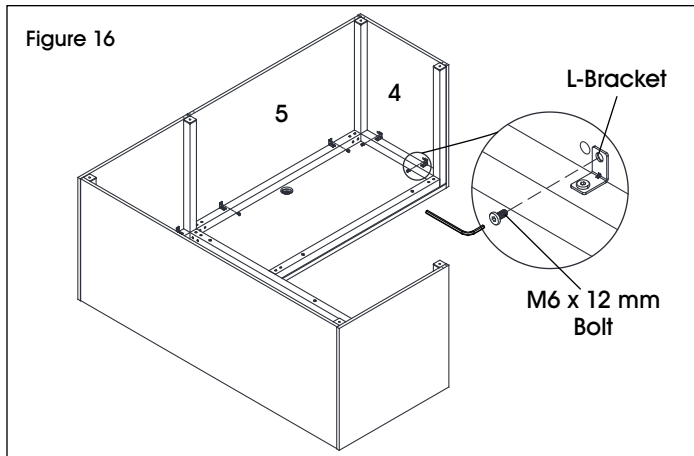

12. Attach base brackets to legs on inside corners with four M4 x 16 mm screws. Attach connector bracket with four M4 x 16 mm screws to secure L-Desk modesty panel to adjacent leg panel. Insert floor glides into legs. (See Figure 17)

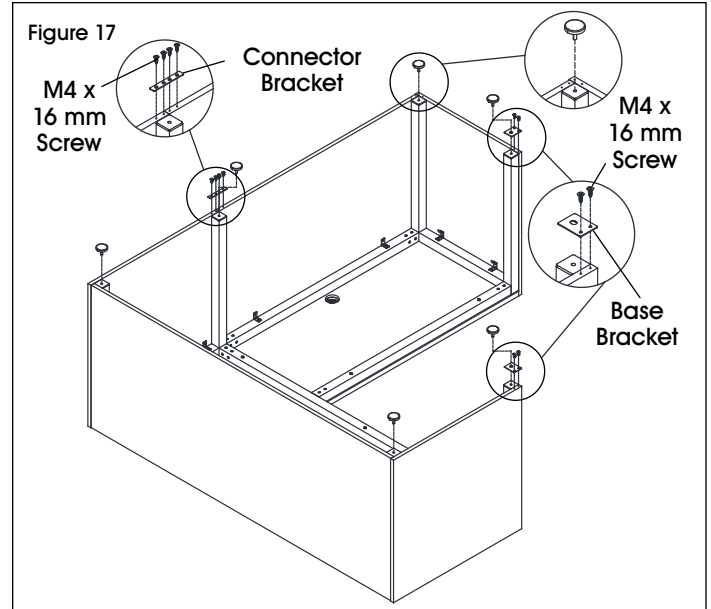

13. With two or three people, set desk upright. Adjust floor glides to compensate for uneven floors.



To finish L-Desk assembly, proceed to Transaction Counter Assembly.

TRANSACTION COUNTER ASSEMBLY

 **NOTE:** Parts for transaction counter are included in the Reception Desk parts list on page 1.

1. Place countertop panel (6) upside down with holes facing up. With second person, position privacy screen panels (7, 8 and 9). Use eight M6 x 12 mm bolts to secure to countertop panel (6). (See Figure 18)

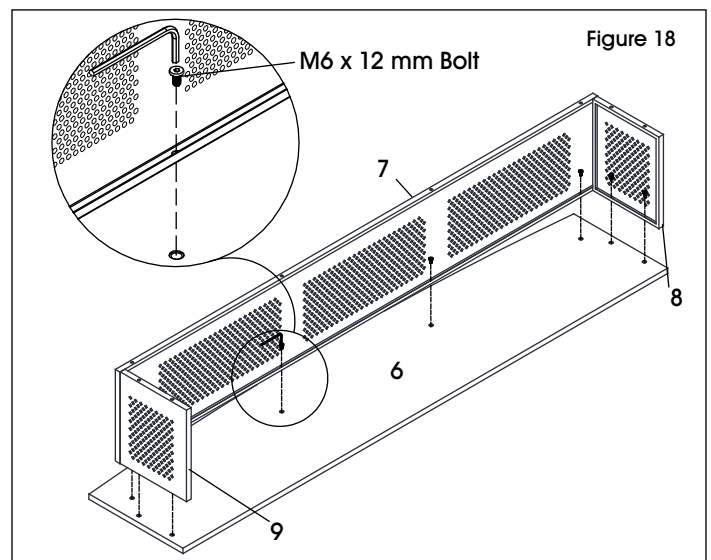

TRANSACTION COUNTER ASSEMBLY CONTINUED

2. With second person, turn assembled transaction counter upright. Use eight M6 x 15 mm bolts to secure to desktop. (See Figure 19)

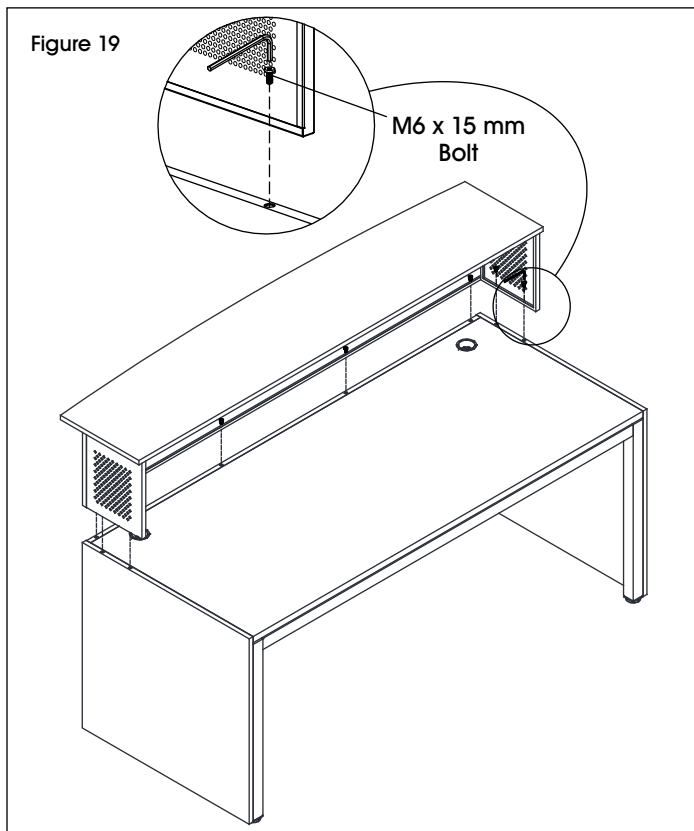

COMPLETED RECEPTION DESK

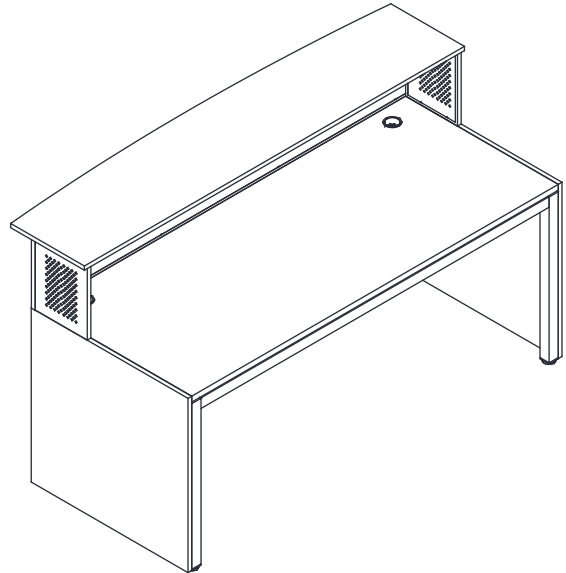

COMPLETED RECEPTION L-DESK

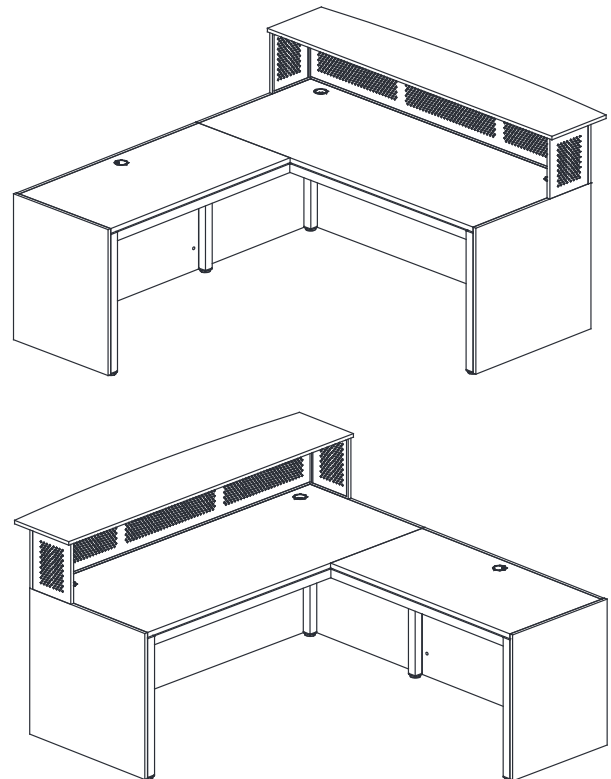

3. Remove backing and apply foam strips into the grooves of the privacy screens. (See Figure 20)
4. Insert black or silver grommet caps into desktop (optional).

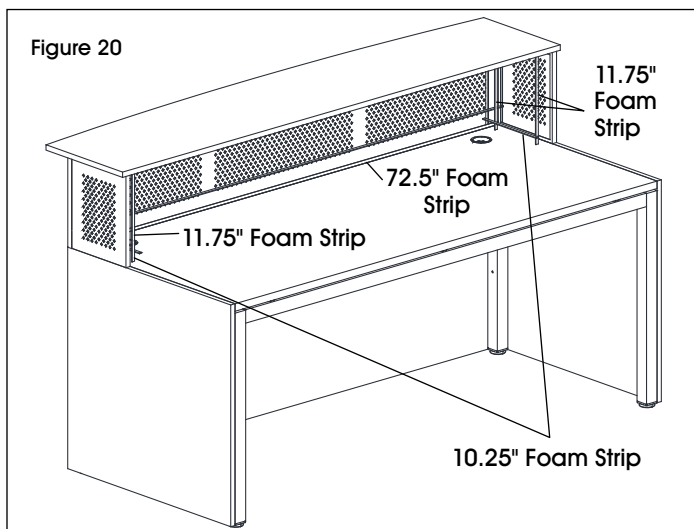

ULINE

1-800-295-5510
uline.com

ULINE H-9752, H-9753

COLECCIÓN URBANA

ESCRITORIO DE RECEPCIÓN

800-295-5510

uline.mx

HERRAMIENTAS NECESARIAS



Se recomienda Armar Entre Tres Personas

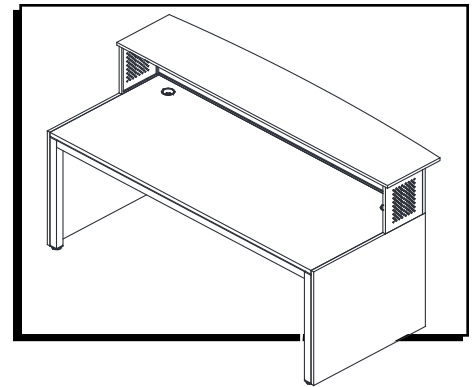

PARTES DEL ESCRITORIO DE RECEPCIÓN



31 Pernos M6 x 12 mm

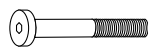

10 Pernos M6 x 65 mm



7 Soportes en L



6 Pasadores de Tuerca Minifix

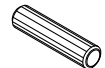

4 Taquetes



6 Tuercas Minifix

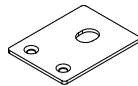

2 Soportes de Base



4 Tornillos M4 x 16 mm



8 Pernos M6 x 15 mm



1 Tira de Espuma de 72.5"



2 Tiras de Espuma de 10.25"



6 Tiras de Espuma de 11.75"

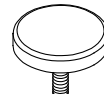

4 Tapas Niveladoras



2 Tapas de Ojal Negras



2 Tapas de Ojal Plateadas

ENSAMBLE DEL ESCRITORIO



NOTA: Ensamble sobre una superficie lisa que no deje marcas para evitar rayones.

- Utilice la llave Allen para apretar todos los tornillos.
- Use un desarmador para apretar los pasadores para tuerca minifix, las tuercas minifix y los tornillos.
- Verifique que todas las partes estén incluidas.

1. Acomode el riel de soporte sobre su soporte correspondiente en la pata. Use cuatro pernos M6 x 12 mm para asegurar cada lado del riel de soporte. Repita la operación con el riel de soporte restante. (Vea Diagrama 1)



Para continuar el ensamble del escritorio (H-9752), proceda al paso 2 a continuación.



Para continuar el ensamble del escritorio en L (H-9753), proceda al Ensamble del Escritorio en L en la página 12.

Diagrama 1

Siga el patrón de orificios en el armazón como se muestra.

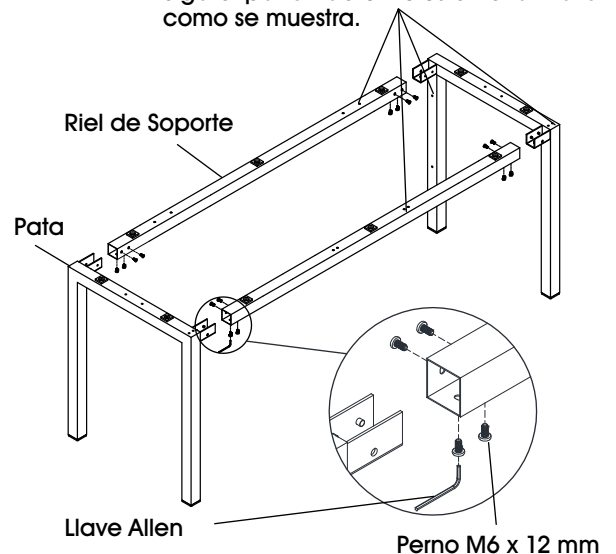

CONTINUACIÓN DE ENSAMBLE DEL ESCRITORIO

2. Coloque la cubierta boca abajo con los orificios hacia arriba. Con ayuda de otra persona, voltee el armazón ensamblado al revés. Use 10 pernos M6 x 65 mm para asegurar el armazón a la cubierta del escritorio incorporando siete soportes en L a lo largo de los lados y la parte posterior del armazón. (Vea Diagrama 2)

 **NOTA:** No apriete los pernos hasta completar el paso 6.

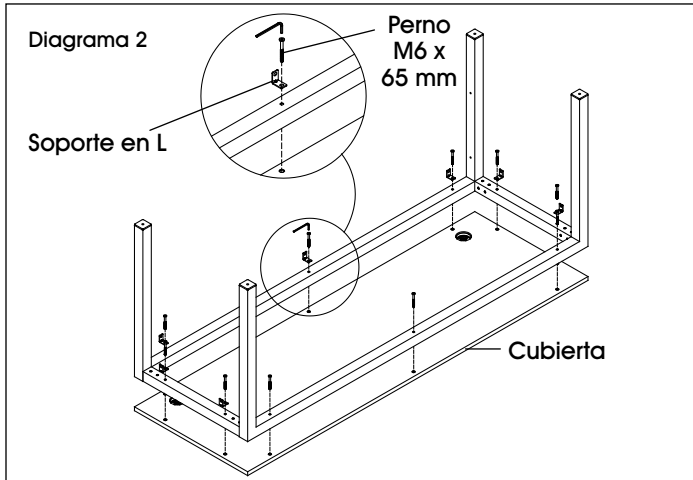

3. Coloque el escritorio ensamblado a un lado. Instale seis pasadores de tuerca minifix e inserte cuatro taquetes en los paneles de las patas (2 y 3). Inserte seis tuercas minifix (B) en los orificios correspondientes en el recato (1). (Vea Diagrama 3)
4. Junte los paneles de las patas (2 y 3) y el recato (1) y gire cada tuerca minifix en el sentido de las manecillas del reloj hasta que se bloqueen. (Vea Diagrama 3)



¡IMPORTANTE! La flecha en la tuerca minifix debe apuntar hacia el pasador de tuerca minifix para una correcta alineación.

Gire la tuerca minifix 1/4 en el sentido de las manecillas del reloj. (Vea Diagrama 3)

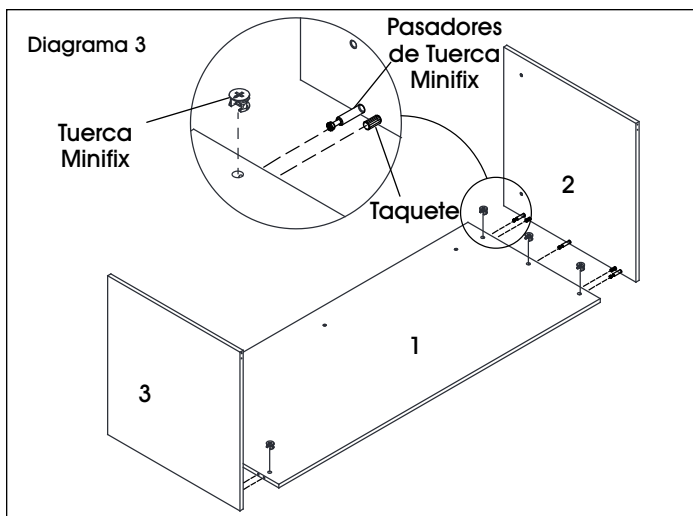

5. Coloque los paneles ensamblados alrededor del exterior del armazón ensamblado con el recato en el mismo lado que los orificios para ojal. (Vea Diagrama 4)

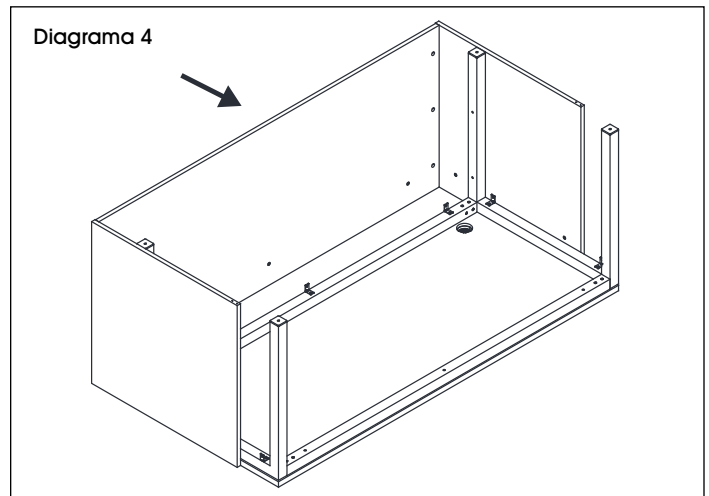

6. Use siete pernos M6 x 12 mm para asegurar la estructura a los soportes en L. Apriete todos los pernos M6 x 65 del paso 2 con la llave Allen. (Vea Diagrama 5)

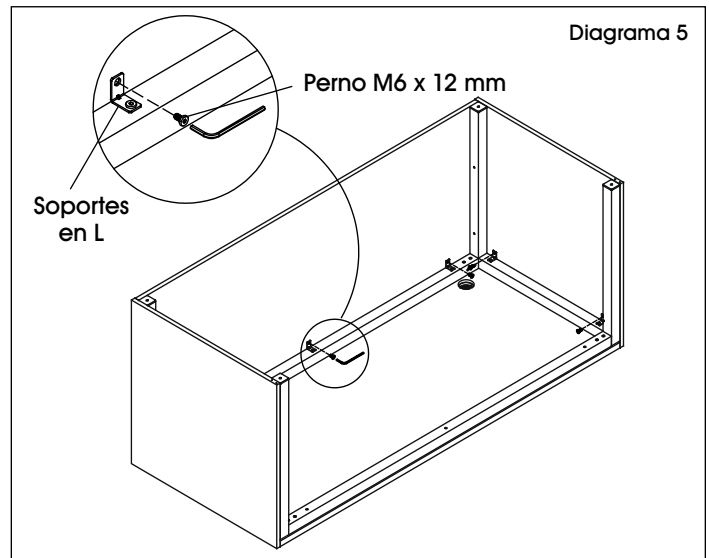

CONTINUACIÓN DE ENSAMBLE DEL ESCRITORIO

7. Fije dos soportes de base a las patas del lado opuesto al recato con cuatro tornillos M4 x 16 mm. (Vea Diagrama 6)

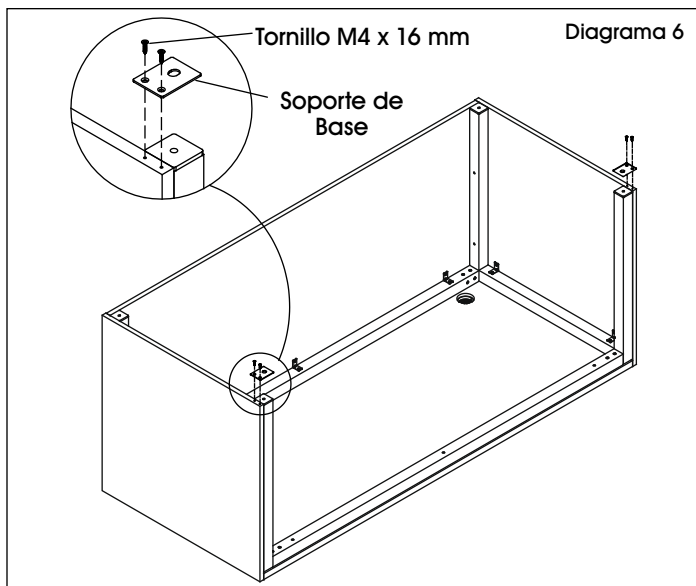

8. Inserte las tapas niveladoras en las patas. (Vea Diagrama 7)

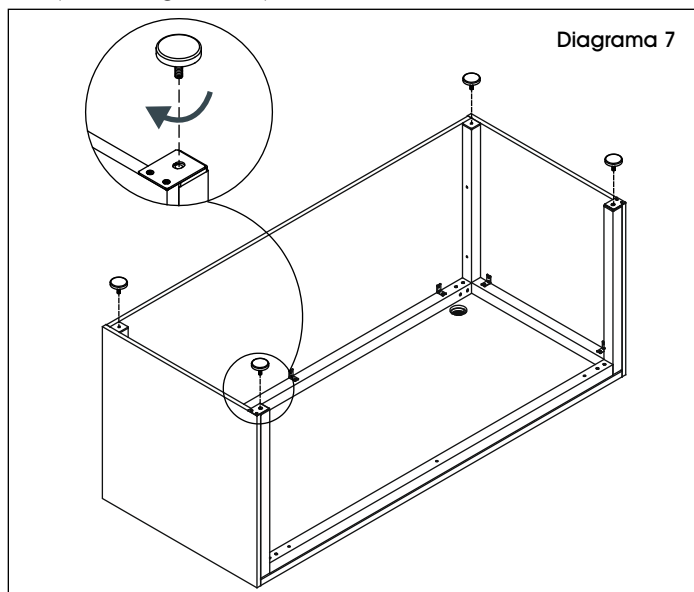

9. Con ayuda de otra persona, enderece el escritorio. Ajuste las tapas niveladoras para compensar los pisos desnivelados.

ALTO Para terminar el ensamble del escritorio, proceda al ensamble del Mostrador en la página 13.

PARTES DEL ESCRITORIO DE RECEPCIÓN EN L



12 Pernos M6 x 12 mm

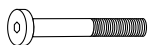

6 Pernos M6 x 65 mm



4 Soportes en L



3 Pasadores de Tuerca Minifix



2 Taquetes



3 Tuercas Minifix



4 Tornillos M4 x 16 mm



4 Pernos M6 x 15 mm

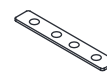

1 Soporte de Unión



3 Tapas Grandes para Tuercas Minifix



2 Tapas Chicas para Tuercas Minifix

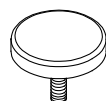

2 Tapas Niveladoras



1 Tapa de Ojal Negra



1 Tapa de Ojal Plateada

ENSAMBLE DEL ESCRITORIO EN L

NOTA: Las Partes del Escritorio de Recepción en L están incluidas en la lista de partes del Escritorio de Recepción en la página 8 y la lista de partes del Escritorio de Recepción en L en la página 11.

1. Ensamble el Escritorio en L. Acomode el riel de soporte sobre su soporte correspondiente en la pata. Use cuatro pernos M6 x 12 mm para asegurarlo. Repita la operación con el riel de soporte restante. (Vea Diagrama 8)

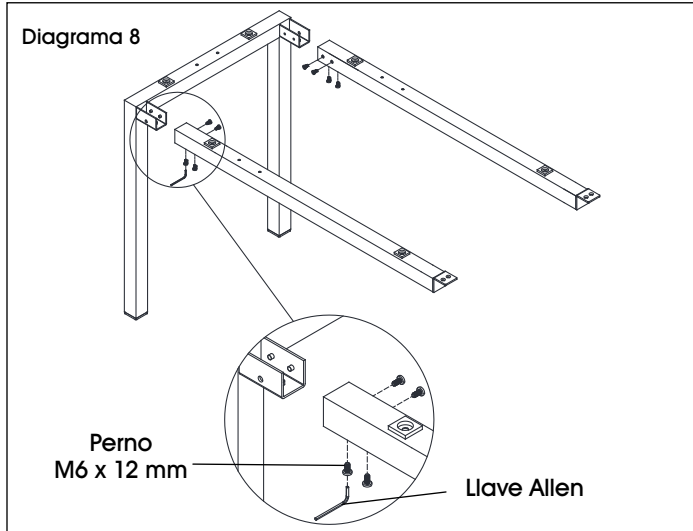

2. Coloque el armazón del escritorio en L ensamblado sobre los orificios de la estructura del escritorio ensamblada. Use cuatro pernos M6 x 15 mm para asegurarlo. (Vea Diagrama 9)

NOTA: El Diagrama 9 muestra la configuración para zurdos. Para la configuración para diestros, fije el retorno del escritorio en L al lado opuesto del armazón de escritorio ensamblado.

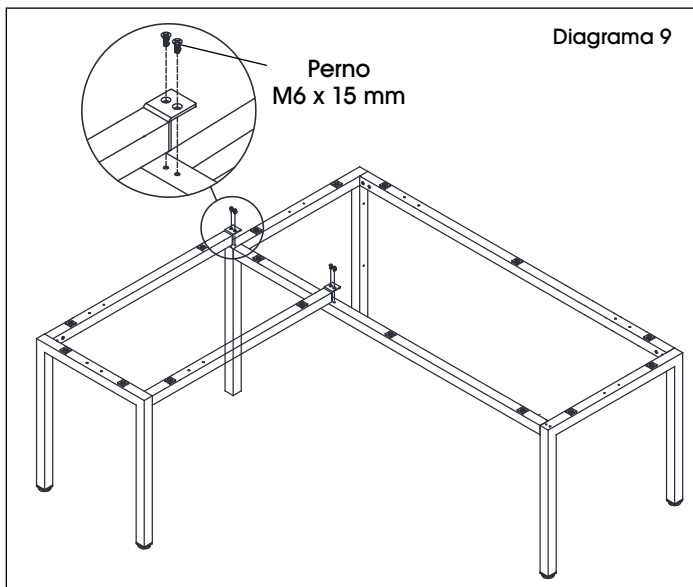

3. Coloque las cubiertas de escritorio boca abajo con los orificios hacia arriba. Entre dos o tres personas, volteen el armazón ensamblado del Escritorio en L. Use 16 pernos M6 x 65 mm para asegurar el armazón a las cubiertas incorporando 11 Soportes en L a lo largo de los lados y la parte posterior del armazón. (Vea Diagrama 10)

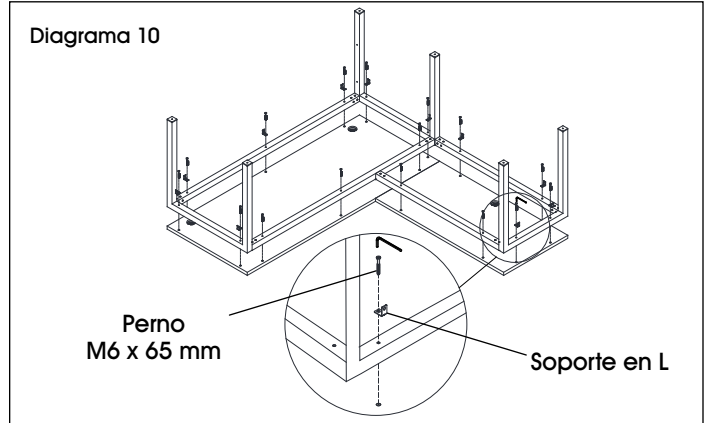

4. Coloque el Escritorio en L ensamblado a un lado. Instale seis pasadores de tuerca minifix e inserte cuatro taquetes en los paneles de las patas (2 y 3). Inserte seis tuercas minifix (B) en los orificios correspondientes en el recato (1). (Vea Diagrama 11)

5. Junte los paneles de las patas (2 y 3) y el recato (1) y gire cada tuerca minifix en el sentido de las manecillas del reloj hasta que se bloqueen. (Vea Diagrama 11)



¡IMPORTANTE! La flecha en la tuerca minifix debe apuntar hacia el pasador de tuerca minifix para una correcta alineación. Gire la tuerca minifix 1/4 en el sentido de las manecillas del reloj. (Vea Diagrama 11)

¡IMPORTANTE: Función de la Tuerca Minifix

Gire 1/4 en el Sentido de las Manecillas del Reloj para Asegurar

Confirme que la flecha apunte hacia arriba antes de insertarla en el orificio del panel.

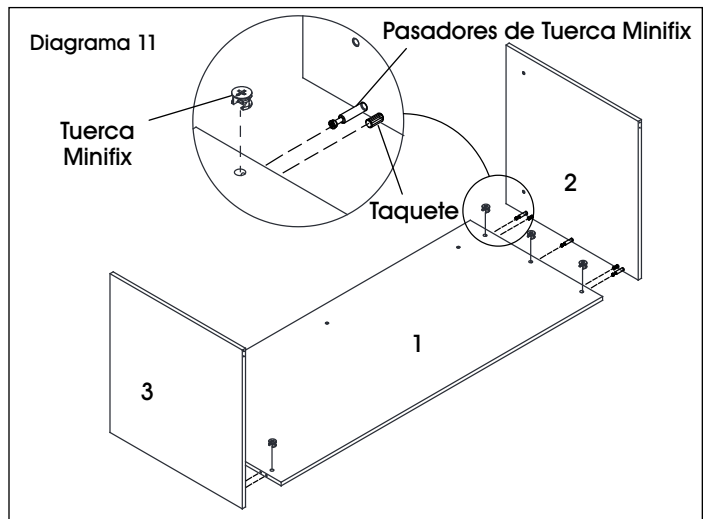

CONTINUACIÓN DEL ENSAMBLE DEL ESCRITORIO EN L

6. Coloque los paneles ensamblados alrededor del exterior del armazón ensamblado del Escritorio en L con el recato en el mismo lado que los orificios para ojal. (Vea Diagrama 12)

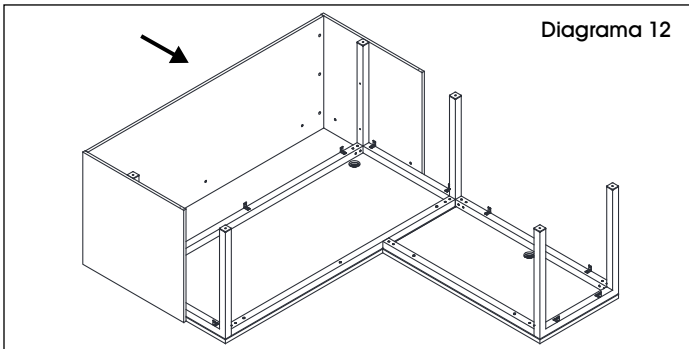

7. Use siete pernos M6 x 12 mm para asegurar la estructura del escritorio a los soportes en L. (Vea Diagrama 13)

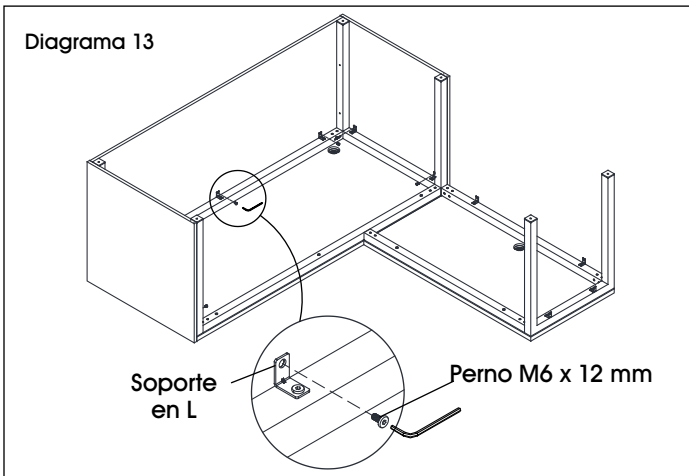

8. Instale tres pasadores de tuerca minifix e inserte dos taquetes en el panel de la pata (4). Inserte tres tuercas minifix en los orificios correspondientes en el recato del retorno del Escritorio en L. (Vea Diagrama 14)
9. Junte el panel de la pata (4) con el recato (5) y gire cada tuerca minifix en el sentido de las manecillas del reloj hasta que se bloqueen. (Vea Diagrama 14)

 **NOTA:** El Diagrama 14 muestra la configuración para zurdos. Para la configuración para diestros, fije el panel de la pata al lado opuesto del recato.

 **NOTA:** Las tapas para tuerca minifix son decorativas. Puede instalarlas después de completar el ensamble.

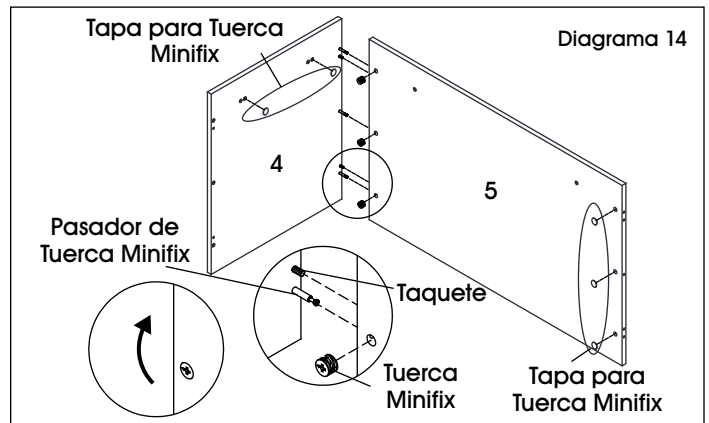

10. Coloque los paneles ensamblados del Escritorio en L alrededor del exterior del armazón ensamblado del escritorio en L con el recato en el mismo lado que los orificios para ojal. (Vea Diagrama 15)

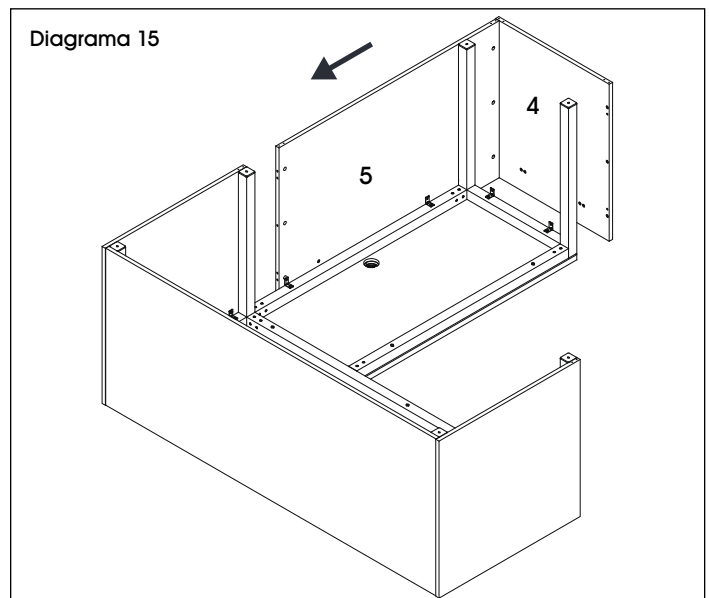

CONTINUACIÓN DEL ENSAMBLE DEL ESCRITORIO EN L

11. Use cuatro pernos M6 x 12 mm para asegurar los paneles a los soportes en L. (Vea Diagrama 16)

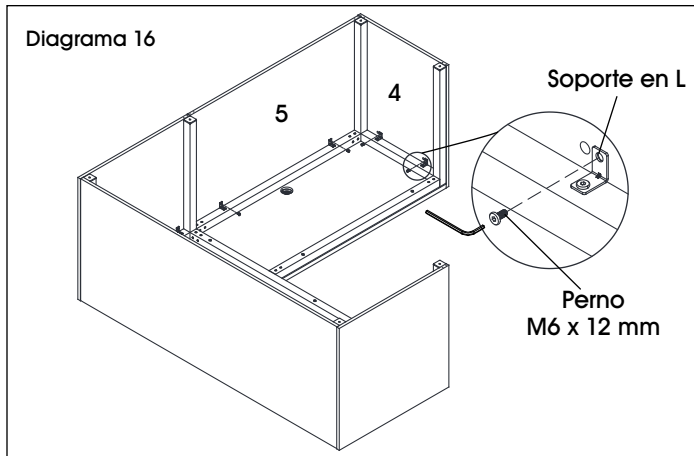

12. Fije dos soportes de base a las patas del lado opuesto al recato con cuatro tornillos M4 x 16 mm. Fije el recato del escritorio en L con el panel de la pata adyacente utilizando el soporte de unión y tres tornillos M4 x 16 mm. Inserte las tapas niveladoras en las patas. (Vea Diagrama 17)

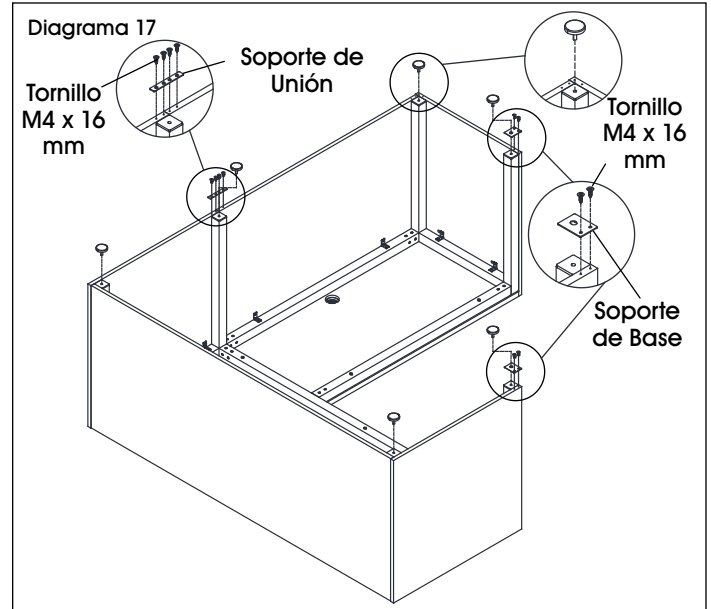

13. Con ayuda de dos o tres personas, enderece el escritorio. Ajuste las tapas niveladoras para compensar los pisos desnivelados.



Para terminar el ensamblaje del Escritorio en L, proceda al Ensamblaje del Mostrador.

ENSAMBLE DEL MOSTRADOR

 **NOTA:** Las partes del mostrador están incluidas en la lista de partes del Escritorio de Recepción en la página 8.

1. Coloque la cubierta del mostrador (6) boca abajo con los orificios hacia arriba. Con ayuda de otra persona, coloque los paneles de malla de privacidad (7, 8 y 9). Use ocho pernos M6 x 12 mm para asegurarlos a la cubierta del mostrador (6). (Vea Diagrama 18)

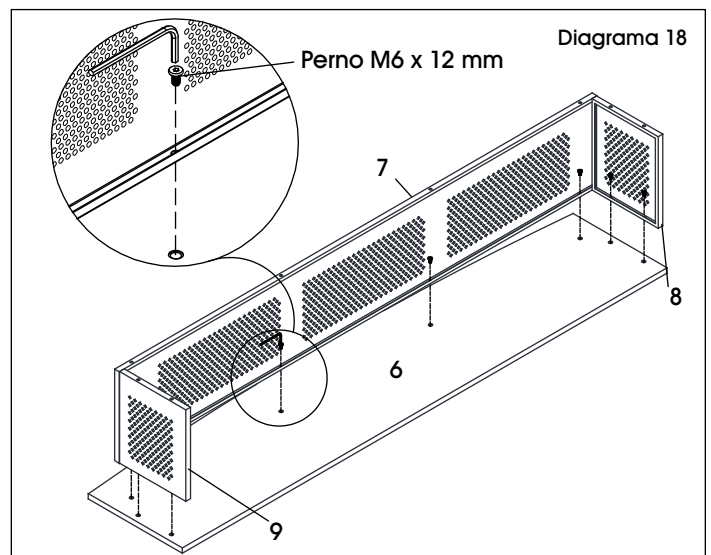

CONTINUACIÓN DE ENSAMBLE DEL MOSTRADOR

2. Con ayuda de una segunda persona, enderece el mostrador ensamblado. Use ocho pernos M6 x 15 mm para asegurarlo a la cubierta del escritorio. (Vea Diagrama 19)

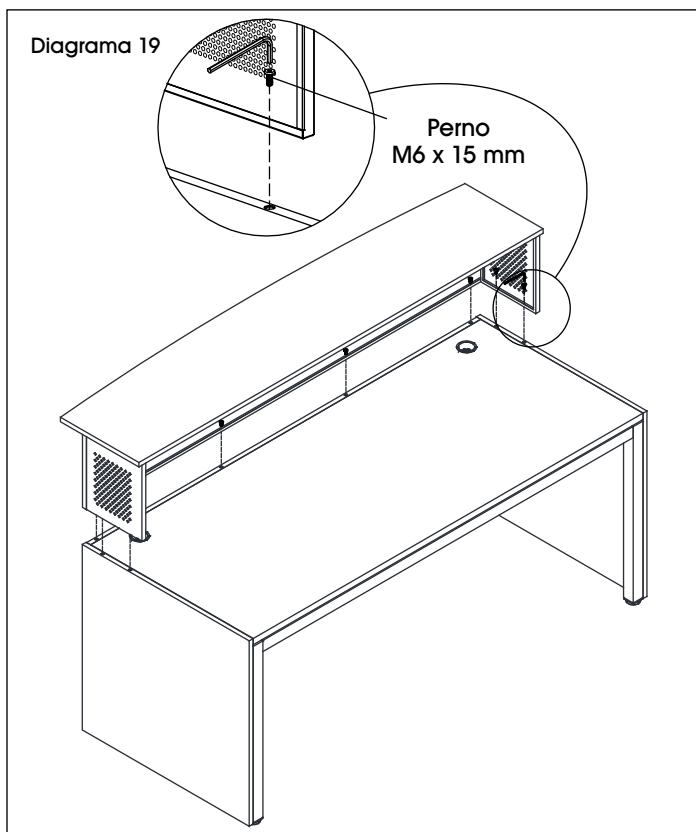

ESCRITORIO DE RECEPCIÓN COMPLETO

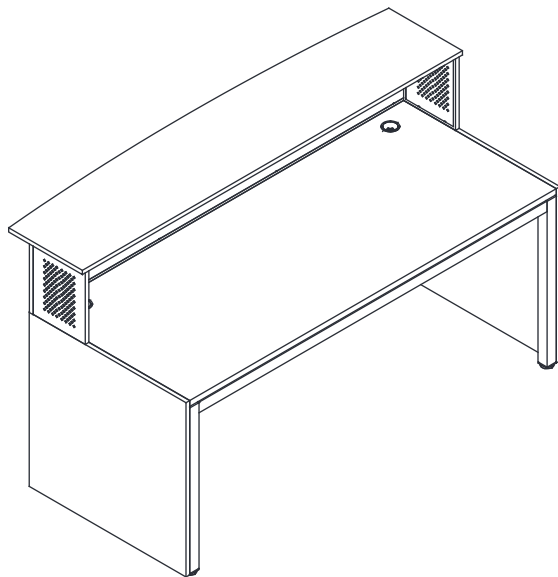

ESCRITORIO DE RECEPCIÓN EN L COMPLETO

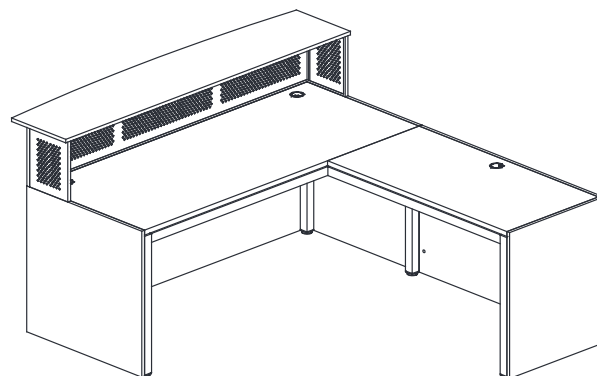
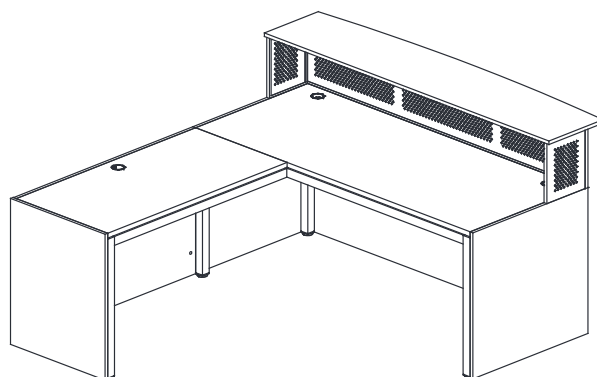

3. Retire el respaldo protector de las tiras de espuma y aplíquelas en las ranuras de las mallas de privacidad. (Vea Diagrama 20)
4. Inserte las tapas de ojales negras y plateadas en la cubierta (opcional).

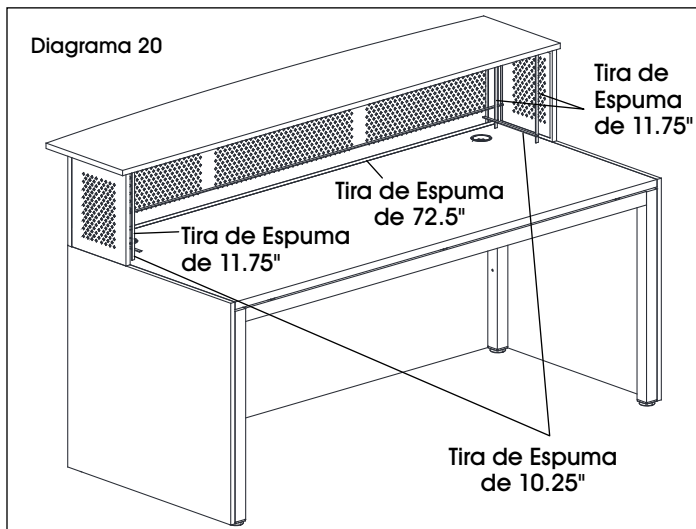

ULINE

800-295-5510
uline.mx

ULINE H-9752, H-9753
COLLECTION DOWNTOWN
 BUREAU D'ACCUEIL

1-800-295-5510
 uline.ca

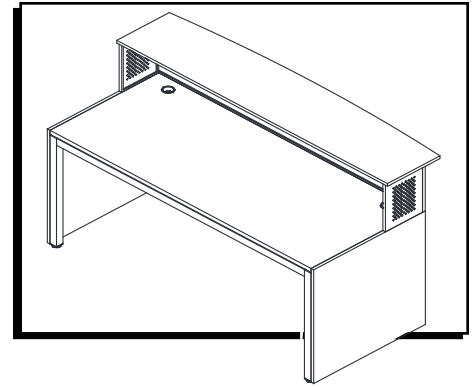

OUTILS REQUIS



Montage à trois personnes
 recommandé

PIÈCES DU BUREAU D'ACCUEIL



Boulon M6 x 12 mm x 31

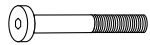

Boulon M6 x 65 mm x 10



Support en L x 7



Goujon d'excentrique x 6

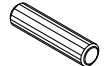

Cheville x 4



Excentrique x 6

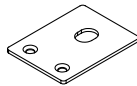

Support de base x 2



Vis M4 x 16 mm x 4



Boulon M6 x 15 mm x 8

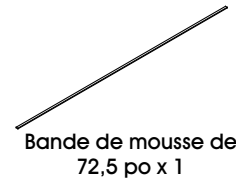

Bande de mousse de
 72,5 po x 1



Bande de mousse de
 10,25 po x 2



Bande de mousse de
 11,75 po x 6

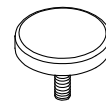

Patin de plancher x 4



Capuchon noir pour
 passe-fil x 2



Capuchon argenté pour
 passe-fil x 2

MONTAGE DU BUREAU



REMARQUE : Montez le bureau sur une surface lisse qui ne marque pas afin d'éviter les rayures.

- Utilisez la clé Allen pour serrer les boulons.
- Utilisez un tournevis cruciforme pour serrer les excentriques, les goujons d'excentrique et les vis.
- Vérifiez que toutes les pièces sont incluses.

1. Placez la barre de soutien sur le support correspondant situé sur le pied. Utilisez quatre boulons M6 x 12 mm pour fixer chaque côté de la barre de soutien. Répétez l'opération pour l'autre barre de soutien. (Voir Figure 1)



Pour continuer le montage du bureau (H-9752), passez à l'étape 2 ci-dessous.



Pour continuer le montage du bureau en L (H-9753), passez au montage du bureau en L à la page 18.

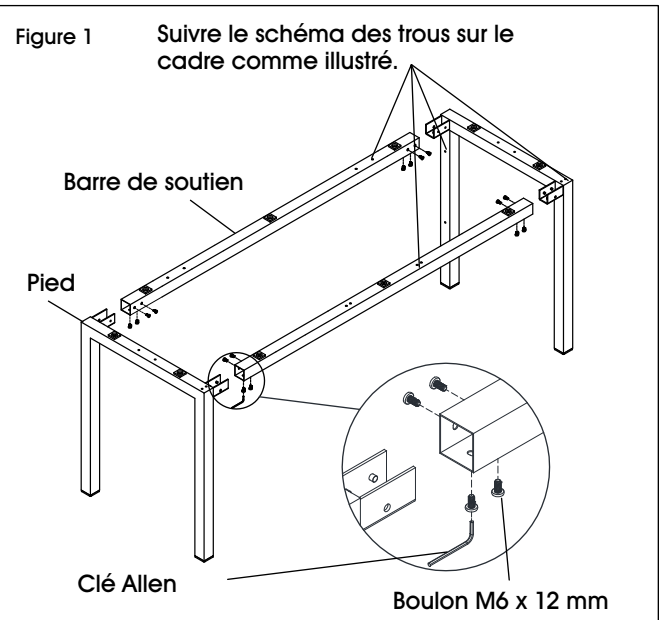

MONTAGE DU BUREAU SUITE

- Placez la surface du bureau à l'envers avec les trous vers le haut. À deux, tournez le cadre monté à l'envers. Fixez le cadre à la surface avec dix boulons M6 x 65 mm (inclus avec la structure du bureau d'accueil) tout en installant les sept supports en L le long des parties latérales et arrière du cadre. (Voir Figure 2)

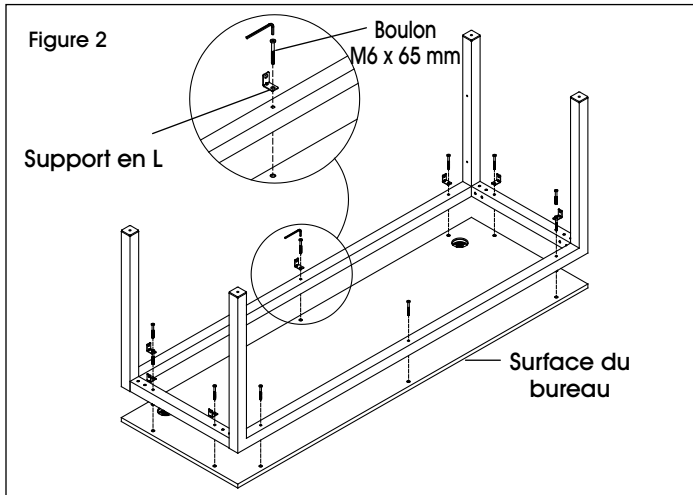

REMARQUE : Ne serrez pas les boulons avant d'avoir complété l'étape 6.

- Placez le bureau monté de côté. Installez six goujons d'excentrique et insérez quatre chevilles dans les panneaux de pied (2 et 3). Insérez six excentriques dans les trous correspondants du panneau cache-jambes (1). (Voir Figure 3)
- Assemblez les panneaux de pied (2 et 3) avec le panneau cache-jambes (1) et tournez chaque excentrique dans le sens horaire jusqu'à ce qu'il se verrouille. (Voir Figure 3)



IMPORTANT! Pour un bon alignement, la flèche de l'excentrique doit être orientée vers l'axe du goujon d'excentrique.

Tournez l'excentrique de 1/4 de tour dans le sens horaire pour le verrouiller. (Voir Figure 3)

IMPORTANT : Fonctionnement de l'excentrique

1/4 de tour dans le sens horaire pour verrouiller

Vérifiez que la flèche pointe vers le haut avant de l'insérer dans le trou du panneau.

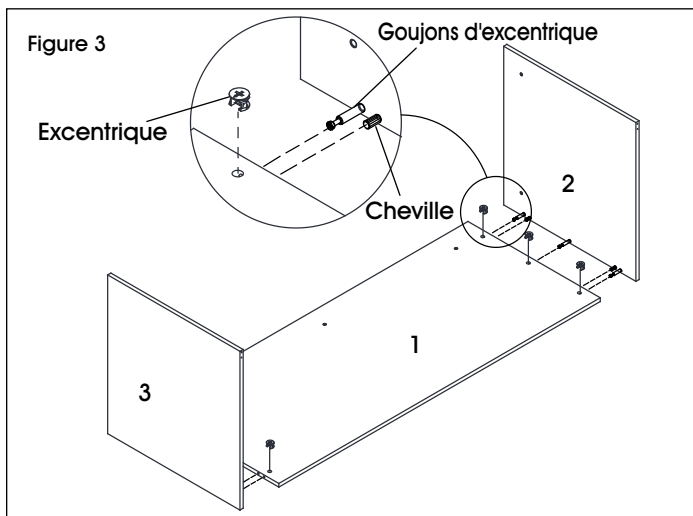

- Disposez les panneaux montés autour du cadre monté auparavant en plaçant le panneau cache-jambes sur le même côté que les trous pour les passe-fils. (Voir Figure 4)

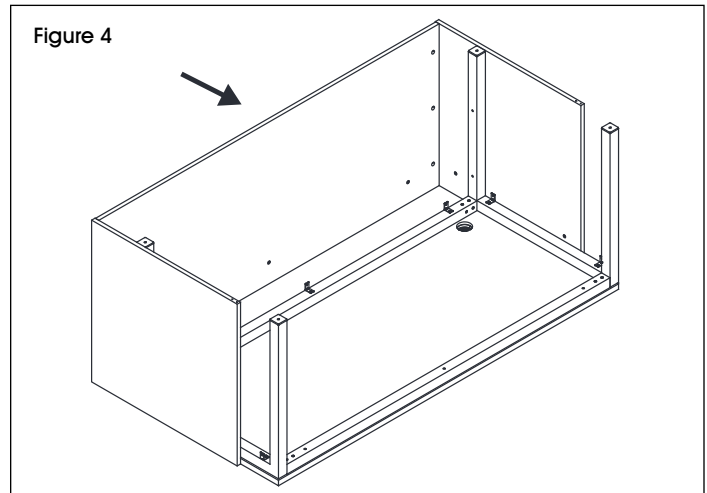

- Fixez la structure aux supports en L avec sept boulons M6 x 12 mm. À l'aide d'une clé Allen, serrez tous les boulons M6 x 65 mm indiqués dans l'étape 2. (Voir Figure 5)

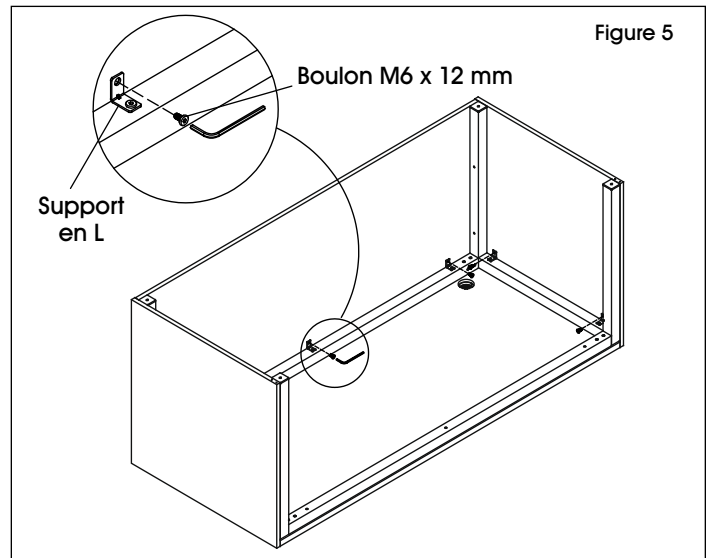

MONTAGE DU BUREAU SUITE

7. Fixez deux supports de base aux pieds se trouvant sur le côté opposé du panneau cache-jambes avec quatre vis M4 x 16 mm. (Voir Figure 6)

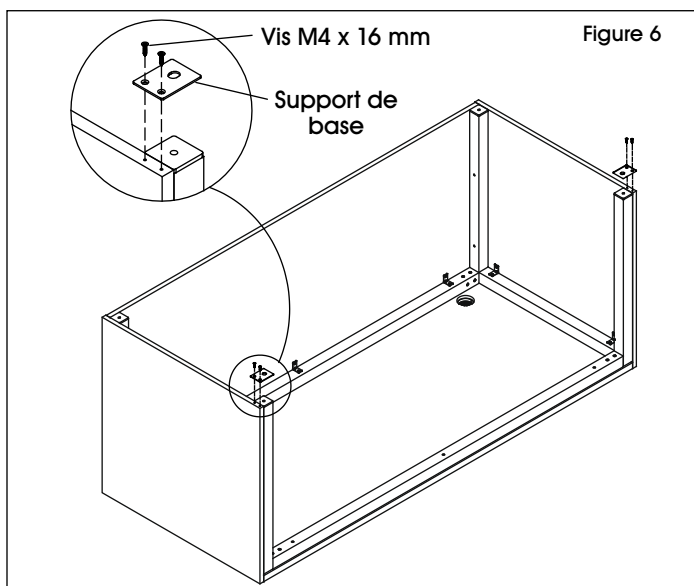

8. Insérez les patins de plancher dans les pieds. (Voir Figure 7)

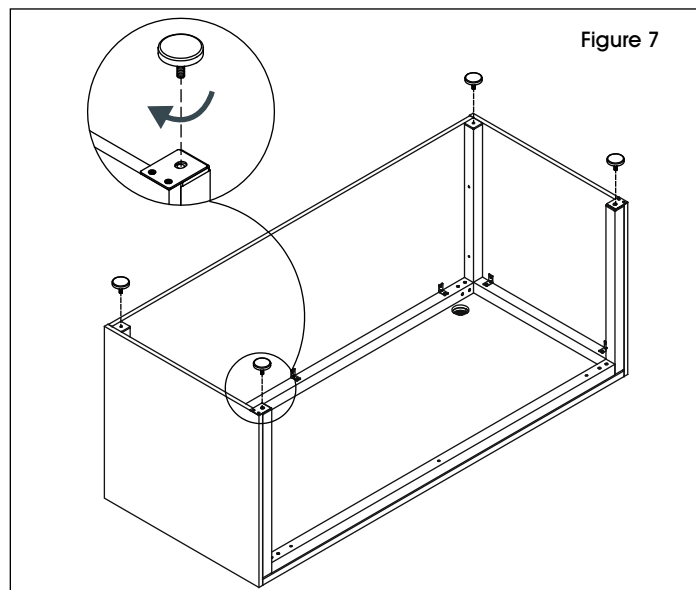

9. À deux, mettez le bureau à l'endroit. Ajustez les patins pour compenser les inégalités du sol.



Pour compléter le montage du bureau, passez au montage du guichet à la page 20.

PIÈCES DU BUREAU D'ACCUEIL EN L



Boulon M6 x 12 mm x 12



Boulon M6 x 65 mm x 6



Support en L x 4



Goujon d'excentrique x 3



Cheville x 2



Excentrique x 3



Vis M4 x 16 mm x 4



Boulon M6 x 15 mm x 4

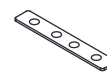

Support de connexion x 1



Grand cache pour excentrique x 3



Petit cache pour excentrique x 2

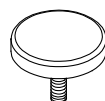

Patin de plancher x 2



Capuchon noir pour passe-fil x 1



Capuchon argenté pour passe-fil x 1

MONTAGE DU BUREAU EN L

REMARQUE : Les pièces du bureau en L figurent sur la liste des pièces du bureau d'accueil à la page 15 et celles du bureau d'accueil en L à la page 17.

1. Montez le bureau en L. Placez la barre de soutien sur le support correspondant situé sur le pied. Fixez-la avec quatre boulons M6 x 12 mm. Répétez l'opération pour l'autre barre de soutien. (Voir Figure 8)

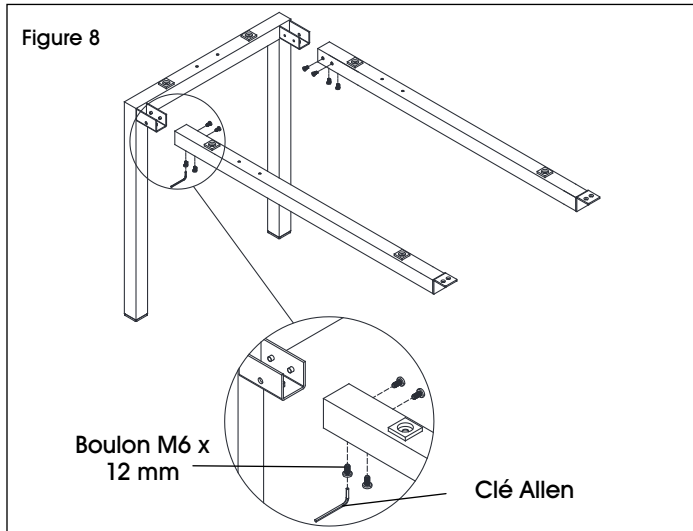

2. Placez le cadre monté du bureau en L sur les trous de la structure montée auparavant. Fixez-le avec quatre boulons M6 x 15 mm. (Voir Figure 9)

REMARQUE : La figure 9 illustre la configuration du côté gauche. Pour une configuration du côté droit, fixez le retour du bureau en L sur le côté opposé du cadre de bureau.

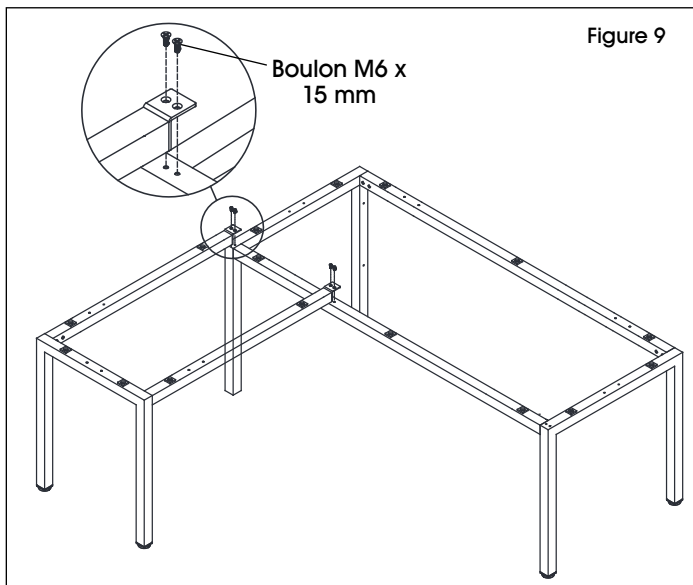

3. Placez les surfaces de bureau à l'envers avec les trous vers le haut. À deux ou à trois personnes, tournez le cadre monté du bureau en L. Fixez-le aux surfaces avec seize boulons M6 x 65 mm (inclus avec la structure du retour et du bureau d'accueil) tout en installant les onze supports en L le long des parties latérales et arrière du cadre. (Voir Figure 10)

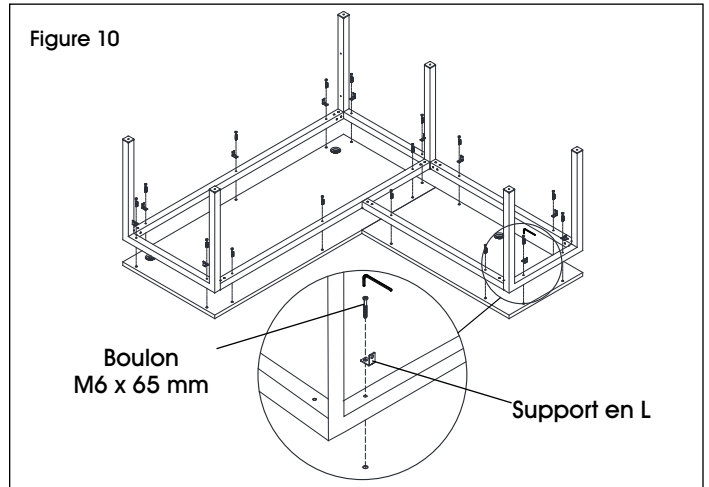

4. Placez le bureau en L monté de côté. Installez six goujons d'excentrique et insérez quatre chevilles dans les panneaux de pied (2 et 3). Insérez six excentriques dans les trous correspondants du panneau cache-jambes (1). (Voir Figure 11)
5. Assemblez les panneaux de pied (2 et 3) avec le panneau cache-jambes (1) et tournez chaque excentrique dans le sens horaire jusqu'à ce qu'il se verrouille. (Voir Figure 11)



IMPORTANT ! Pour un bon alignement, la flèche de l'excentrique doit être orientée vers l'axe du goujon d'excentrique.

Tournez l'excentrique de 1/4 de tour dans le sens horaire pour le verrouiller. (Voir Figure 11)

IMPORTANT : Fonctionnement de l'excentrique

1/4 de tour dans le sens horaire pour verrouiller

Vérifiez que la flèche pointe vers le haut avant de l'insérer dans le trou du panneau.

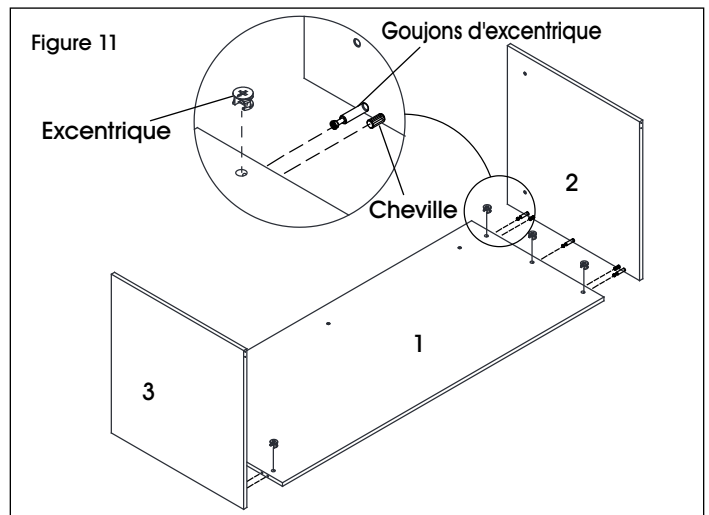

MONTAGE DU BUREAU EN L SUITE

6. Disposez les panneaux montés autour du cadre du bureau en L monté auparavant en plaçant le panneau cache-jambes sur le même côté que les trous pour les passe-fils. (Voir Figure 12)

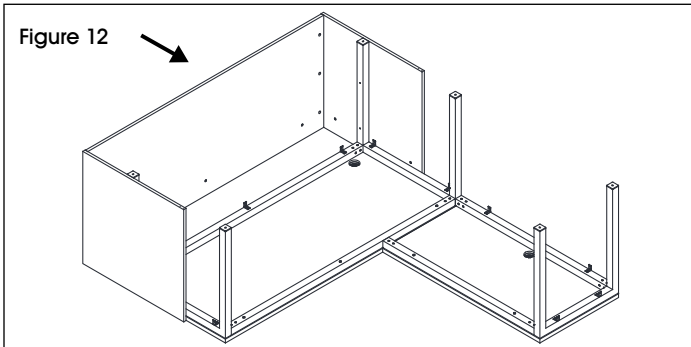

7. Fixez la structure aux supports en L avec sept boulons M6 x 12 mm. (Voir Figure 13)

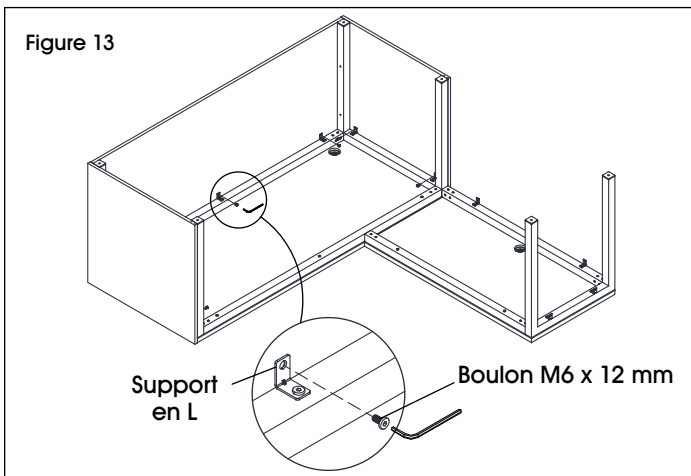

8. Installez trois goujons d'excentrique et insérez deux chevilles dans le panneau de pied (4). Insérez trois excentriques dans les trous correspondants du cache-jambes du retour de bureau en L (5). (Voir Figure 14)
9. Assemblez le panneau de pied (4) avec le panneau cache-jambes (5) et tournez chaque excentrique dans le sens horaire jusqu'à ce qu'il se verrouille. (Voir Figure 14)

 **REMARQUE :** La figure 14 illustre la configuration du côté gauche. Pour une configuration du côté droit, fixez le panneau de pied sur le côté opposé du panneau cache-jambes.

 **REMARQUE :** Les caches pour excentrique sont juste à titre décoratif. Vous pouvez les installer une fois le montage terminé.

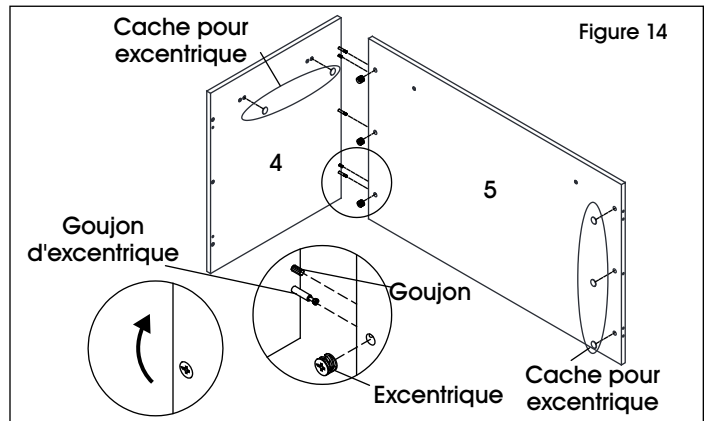

10. Disposez les panneaux montés autour du cadre du bureau en L monté auparavant en plaçant le panneau cache-jambes sur le même côté que le trou pour les passe-fils. (Voir Figure 15)

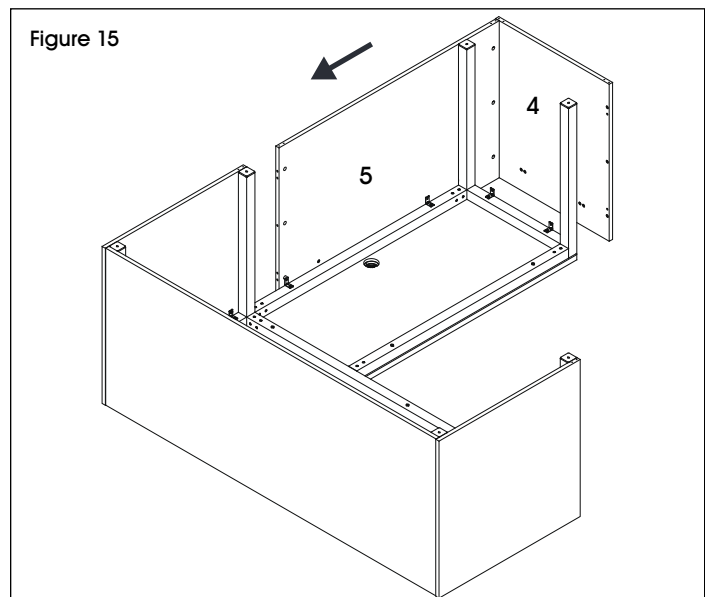

MONTAGE DU BUREAU EN L SUITE

11. Fixez les panneaux aux supports en L avec quatre boulons M6 x 12 mm. (Voir Figure 16)

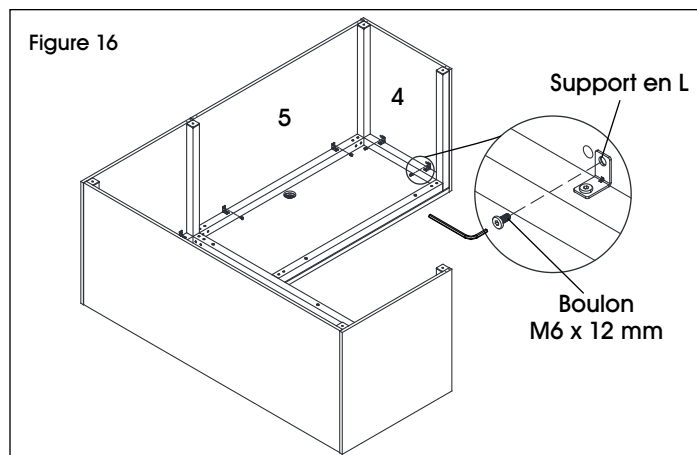

12. Fixez les supports de base aux pieds sur les coins intérieurs avec quatre vis M4 x 16 mm. Installez le support de connexion avec quatre vis M4 x 16 mm pour fixer le panneau cache-jambes du bureau en L au panneau de pied adjacent. Insérez les patins de plancher dans les pieds. (Voir Figure 17)

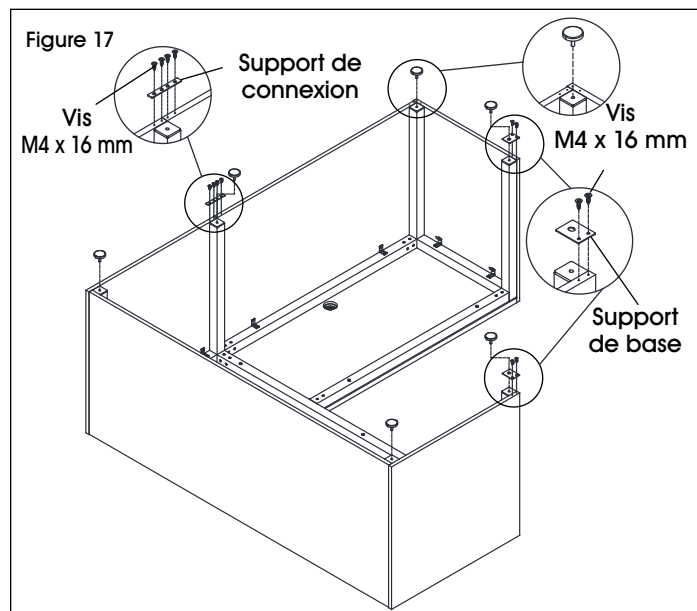

13. À deux ou trois personnes, tournez le bureau à l'endroit. Ajustez les patins pour compenser les inégalités du sol.



Pour compléter le montage du bureau, passez au montage du guichet.

MONTAGE DU GUICHET

 **REMARQUE :** Les pièces du guichet figurent sur la liste des pièces du bureau d'accueil à la page 15.

1. Placez la surface du guichet (6) à l'envers avec les trous vers le haut. À deux, positionnez les panneaux de séparation (7, 8 et 9). Fixez-les à la surface du guichet (6) avec huit boulons M6 x 12 mm. (Voir Figure 18)

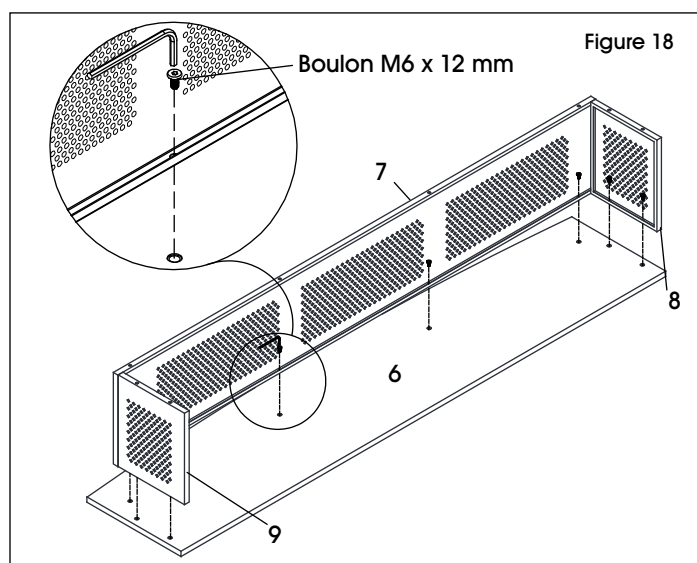

MONTAGE DU GUICHET SUITE

- À deux, tournez le guichet monté à l'endroit. Fixez-le à la surface du bureau avec huit boulons M6 x 15 mm. (Voir Figure 19)

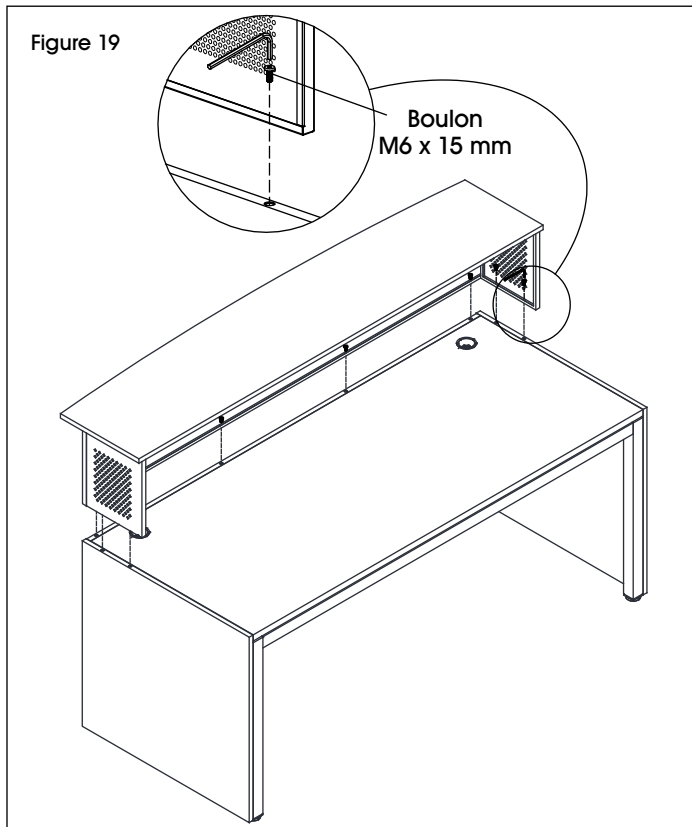

BUREAU D'ACCUEIL ASSEMBLÉ

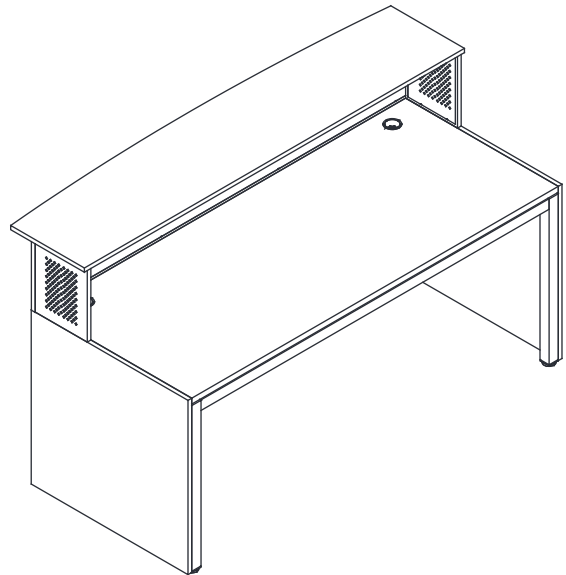

BUREAU D'ACCUEIL EN L ASSEMBLÉ

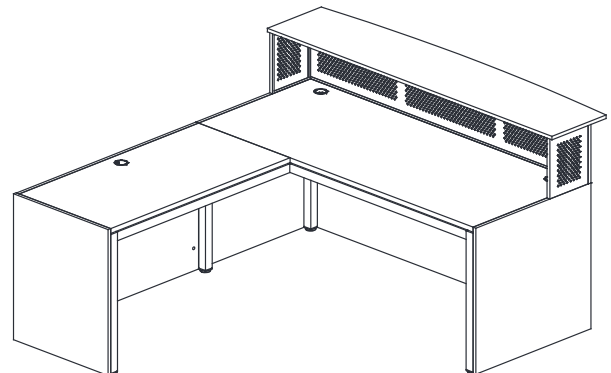

- Enlevez la doublure et appliquez les bandes de mousse dans les rainures des panneaux de séparation. (Voir Figure 20)
- Insérez les capuchons noirs ou argentés pour passe-fils dans la surface (facultatif).

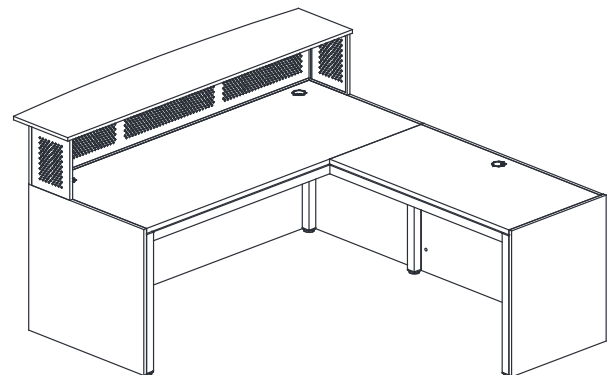
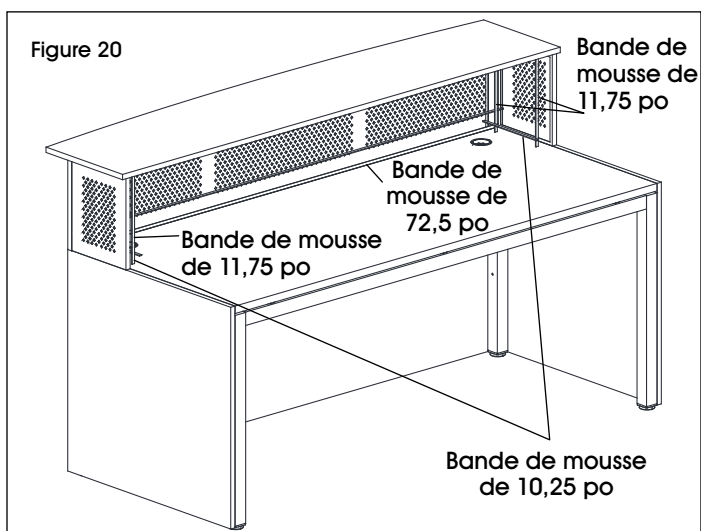

ULINE

1-800-295-5510
uline.ca