

# ULINE H-9757 PLASTIC DRUM DOLLY

1-800-295-5510  
uline.com

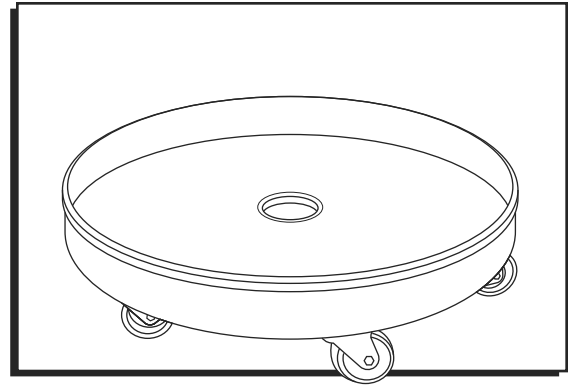

## TOOL NEEDED



1/2" Wrench

## PARTS

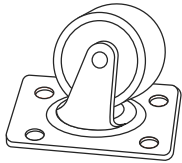

Caster x 5

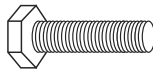

Bolt x 20

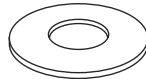

Washer x 20

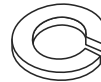

Lock Washer x 20

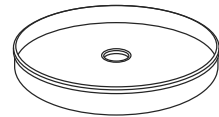

Drum Dolly Frame x 1

## ASSEMBLY

1. Turn drum dolly frame upside down.
2. Align caster with mounting holes on dolly.
3. Attach caster to drum dolly frame using bolt, washer and lock washer. (See Figure 1)
4. Tighten bolts with 1/2" wrench.
5. Repeat for remaining casters.

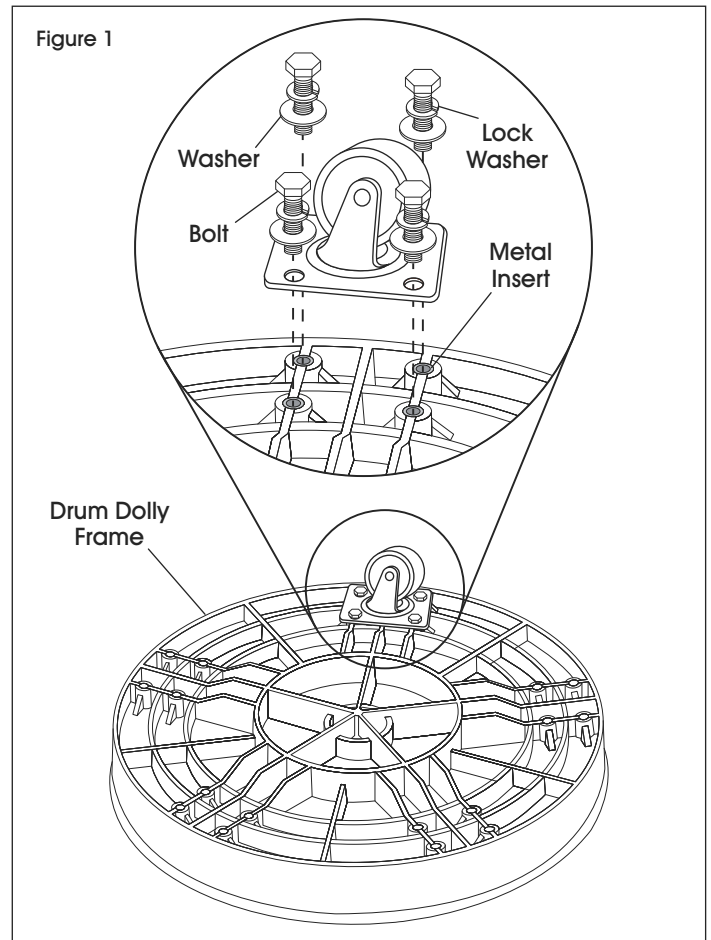

**ULINE H-9757**

800-295-5510

uline.mx

# PLATAFORMA CON RUEDAS PARA TAMBOS DE PLÁSTICO

## HERRAMIENTA NECESARIA



Llave de 1/2"

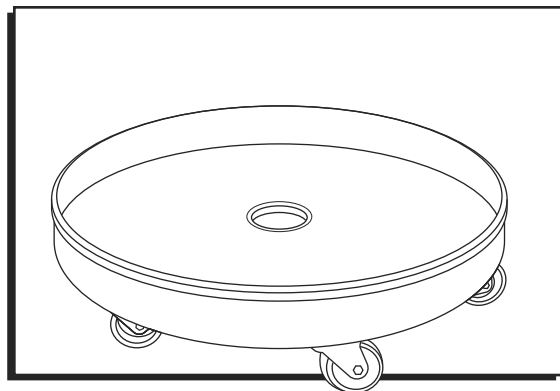

## PARTES

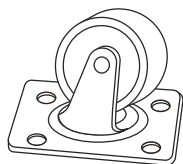

5 Ruedas

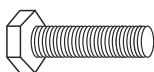

20 Pernos



20 Rondanas



20 Rondanas  
de Seguridad

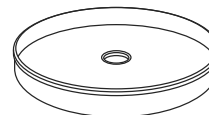

1 Armazón de Plataforma  
para Tambos

## ENSAMBLE

1. Voltee el armazón de la plataforma para tambos.
2. Alinee la rueda con los orificios para instalación de la plataforma.
3. Fije la rueda al armazón de la plataforma para tambos usando un perno, rondana y rondana de seguridad. (Vea Diagrama 1)
4. Apriete los pernos con la llave de 1/2".
5. Repita el proceso para las ruedas restantes.

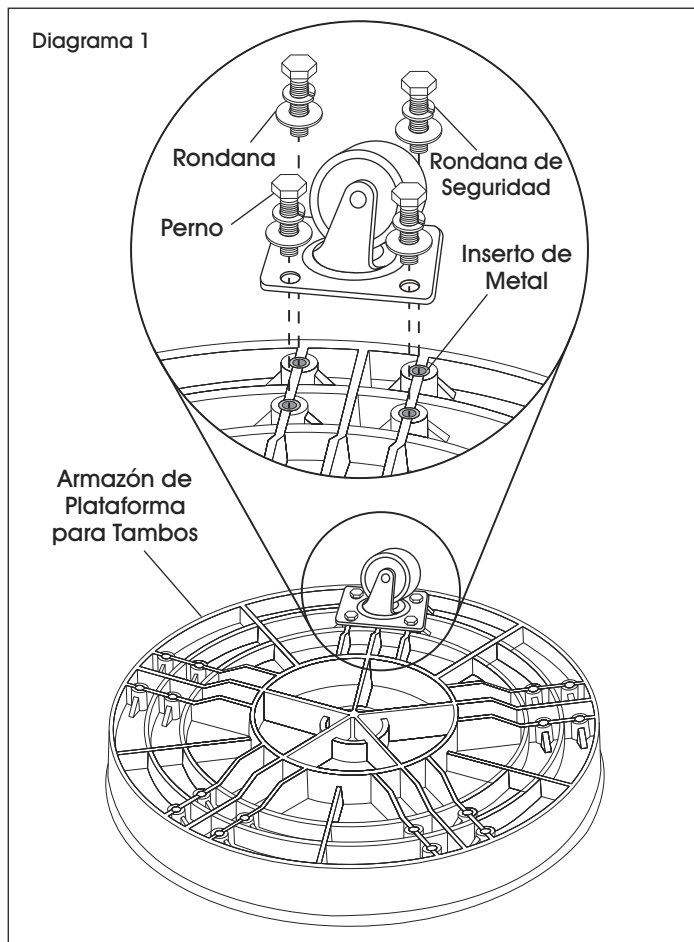

**ULINE** H-9757

# SOCLE ROULANT POUR BARIL EN PLASTIQUE

1-800-295-5510  
uline.ca

## OUTIL REQUIS



Clé de 1/2 po

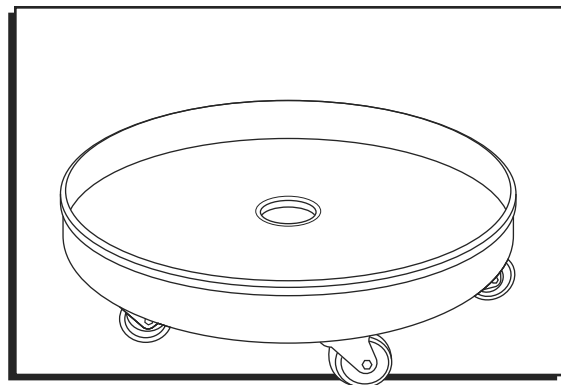

## PIÈCES

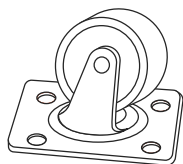

Roulette x 5

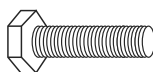

Boulon x 20



Rondelle x 20



Rondelle de  
blocage x 20

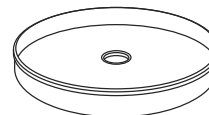

Armature du socle  
roulant pour baril x 1

## MONTAGE

1. Placez l'armature du socle roulant pour baril à l'envers.
2. Alignez une roulette sur les trous de montage du socle roulant.
3. Fixez la roulette au socle roulant pour baril avec des boulons, rondelles et rondelles de blocage. (Voir Figure 1)
4. Serrez les boulons avec une clé de 1/2 po.
5. Répétez l'opération pour les roulettes restantes.

