

ULINE H-9784, H-9785

METRO COLLECTION – MOBILE PEDESTAL FILE

1-800-295-5510
uline.com

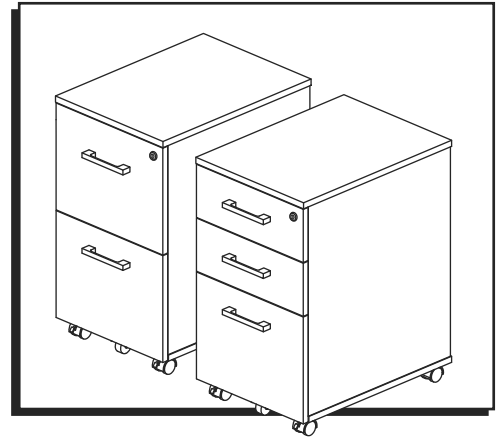

TOOLS NEEDED



Phillips
Screwdriver



Drill

PARTS

A

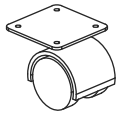

Non-Locking Caster x 2

B

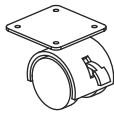

Locking Caster x 2

C

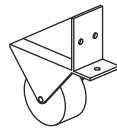

Drawer Caster x 1

D

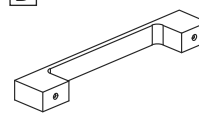

Handle x 2
(x 3 for H-9785)

E

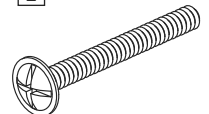

M4 x 34 mm Screw x 4
(x 6 for H-9785)

F

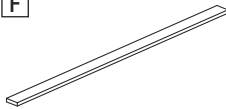

Metal Bar x 1
(x 2 for H-9784)

G



File Clip x 2
(x 4 for H-9784)

H

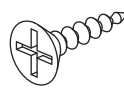

ST 3.5 x 14 mm
Screw x 19

I

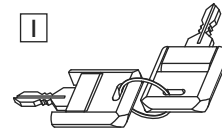

Keys (Set of 2) x 1

ASSEMBLY

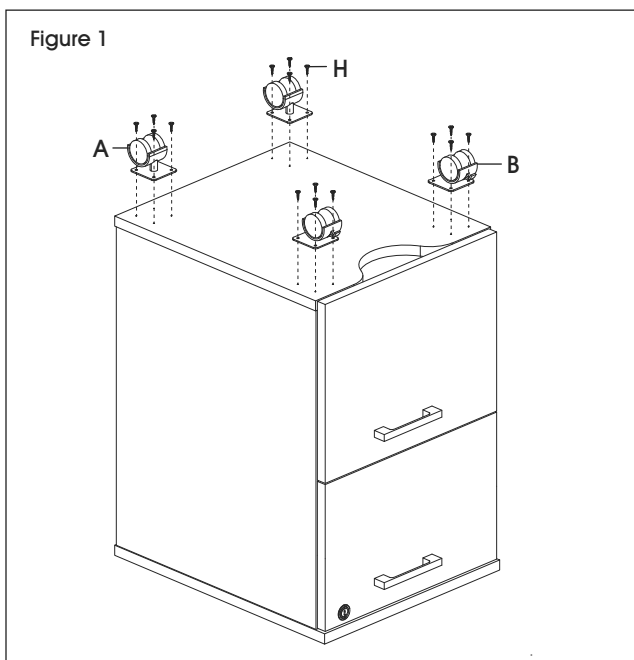

- NOTE:** Assemble unit on a smooth, non-marring surface to prevent scratching.
- NOTE:** Check that all parts are included.
- NOTE:** Tighten all screws with Phillips screwdriver.

1. Remove casters and hardware from drawers.
2. Lock drawers using key and flip product upside down. Align holes on the locking casters (B) with the pre-drilled holes near the front of the unit. Attach using eight ST 3.5 x 14 mm screws (H). (See Figure 1)
3. Align holes on non-locking casters (A) with the pre-drilled holes toward the back of the unit. Attach using eight ST 3.5 x 14 mm screws (H). (See Figure 1)

ASSEMBLY CONTINUED

Figure 2

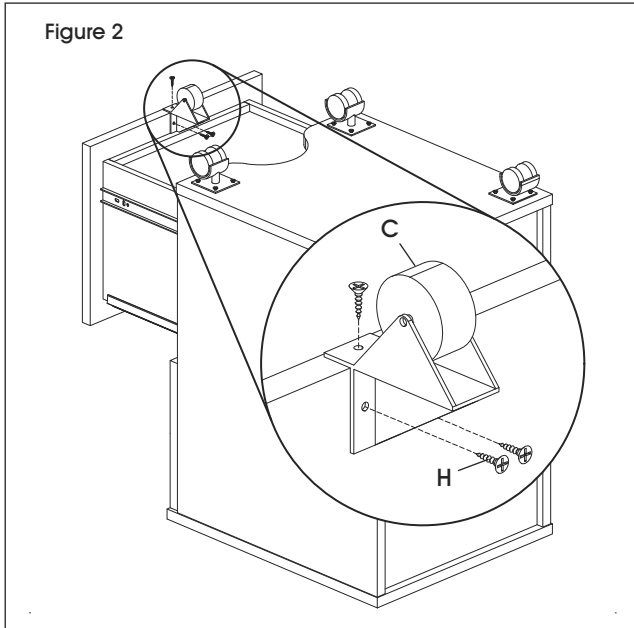

4. Unlock drawers and slowly pull out bottom drawer. Attach drawer caster (C) to the underside of the bottom drawer using three ST 3.5 x 14 mm screws (H) and drill. (See Figure 2)

Figure 3

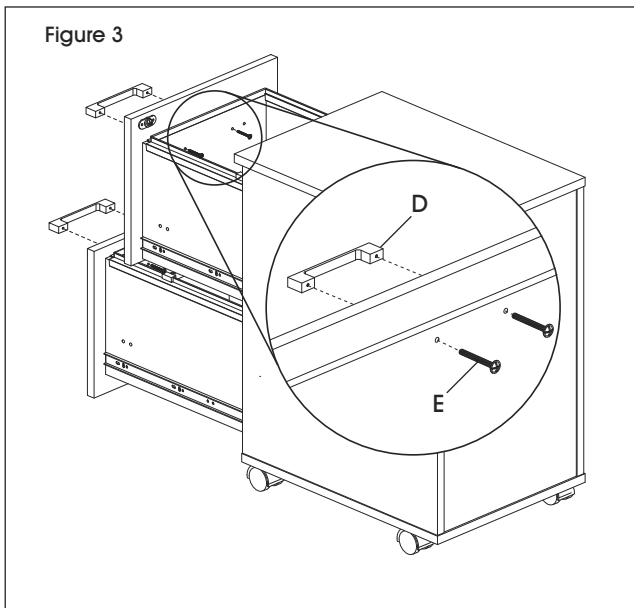

5. Place pedestal file upright. Remove pre-attached handles (D) from inside of drawer and move to the outside of drawer. Align holes on drawer with holes on handle and attach using two M4 x 34 mm screws (E). Repeat for remaining drawer(s). (See Figure 3)

Figure 4

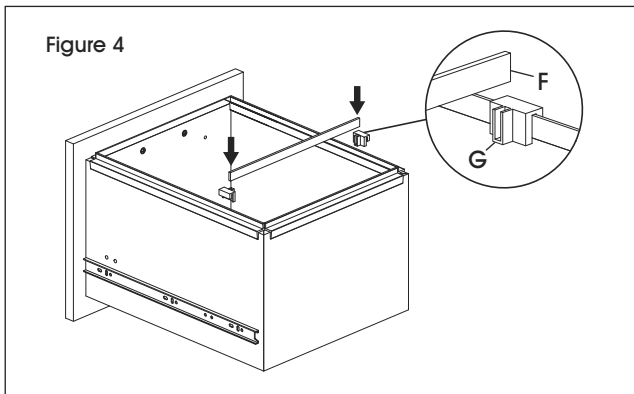

6. Attach file clips (G) to each side of file drawer(s) and insert metal bar (F). (See Figure 4)

ULINE

1-800-295-5510
uline.com

ULINE H-9784, H-9785

COLECCIÓN METROPOLITANA – ARCHIVERO MÓVIL DE PEDESTAL

800-295-5510
uline.mx

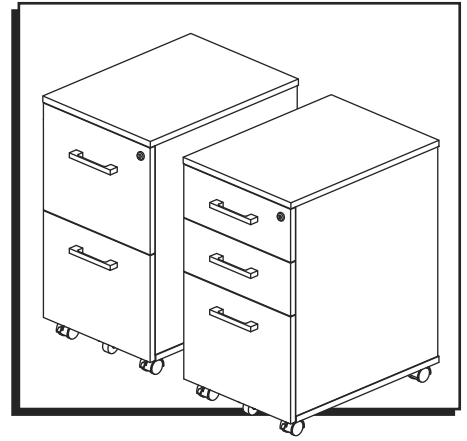

HERRAMIENTAS NECESARIAS

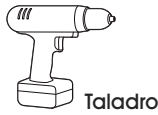

PARTES

A

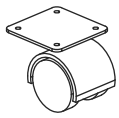

2 Ruedas sin Seguro

B

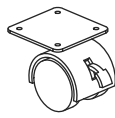

2 Ruedas con Seguro

C

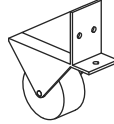

1 Rueda de Cajón

D

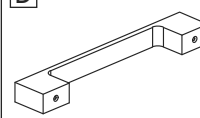

2 Asas
(3 para el H-9785)

E

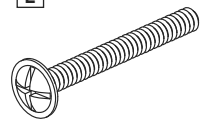

4 Tornillos M4 x 34 mm
(6 para el H-9785)

F

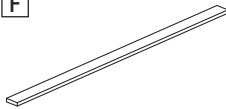

1 Barra de Metal
(2 para el H-9784)

G



2 Clips para Archivo
(4 para el H-9784)

H

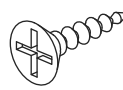

19 Tornillos ST de
3.5 x 14 mm

I

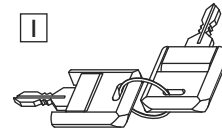

1 Set de 2 Llaves

ENSAMBLE

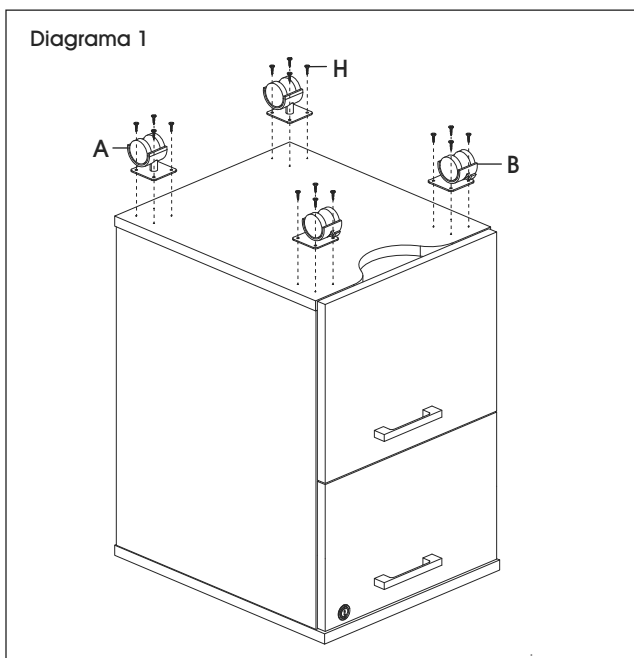

NOTA: Ensamble la unidad sobre una superficie lisa que no deje marcas para evitar rayones.



NOTA: Verifique que todas las partes estén incluidas.



NOTA: Apriete todos los tornillos con el desarmador de cruz.

1. Retire las ruedas y la tornillería de los cajones.
2. Cierre los cajones con la llave y voltee el producto. Alinee los orificios de las ruedas con seguro (B) con los orificios preperforados cerca del frente de la unidad. Fije usando ocho tornillos ST de 3.5 x 14 mm (H). (Vea Diagrama 1)
3. Alinee los orificios de las ruedas sin seguro (A) con los orificios preperforados cerca del frente de la unidad. Fije usando ocho tornillos ST de 3.5 x 14 mm (H). (Vea Diagrama 1)

CONTINUACIÓN DEL ENSAMBLE

Diagrama 2

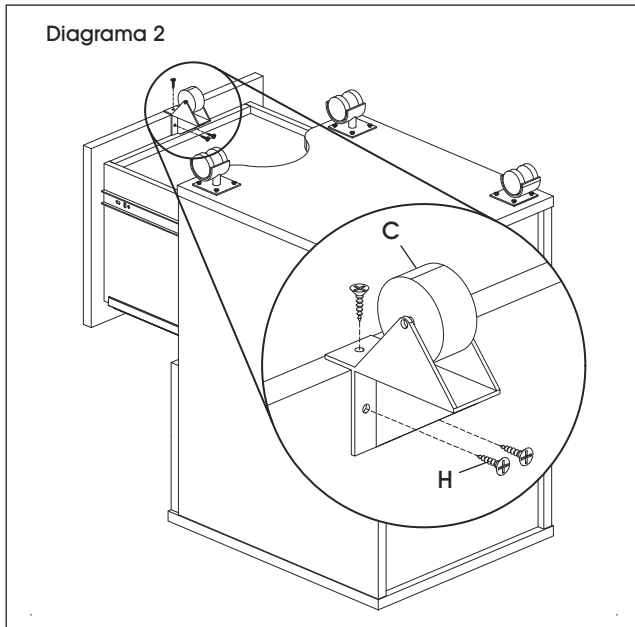

4. Abra los cajones y saque lentamente el cajón inferior. Fije la rueda para cajón (C) en la parte de abajo del cajón inferior usando tres tornillos ST de 3.5 x 14 mm (H) y un taladro. (Vea Diagrama 2)

Diagrama 3

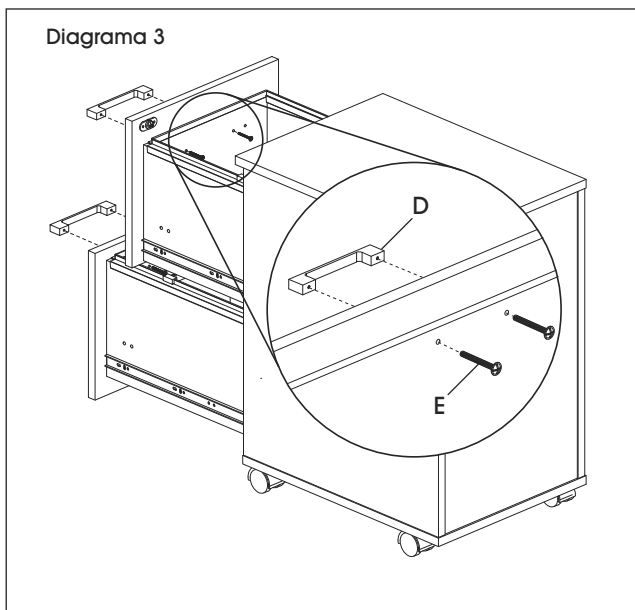

5. Coloque el archivero de pedestal en posición vertical. Retire las asas preinstaladas (D) del interior del cajón y muévalas hacia el exterior del cajón. Alinee los orificios del cajón con los del asa y fije utilizando dos tornillos M4 x 34 mm (E). Repita la operación con el (los) cajón(es) restante(s). (Vea Diagrama 3)

Diagrama 4

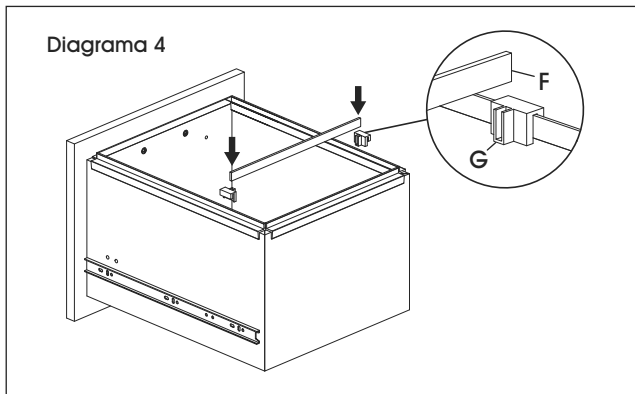

6. Fije los clips para archivo (G) a cada lado del (los) archivero(s) e inserte la barra de metal (F). (Vea Diagrama 4)

ULINE

800-295-5510
uline.mx

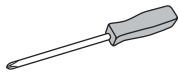
**COLLECTION METRO –
CLASSEUR MOBILE À CAISSON****OUTILS REQUIS**Tournevis
cruziforme

Perceuse

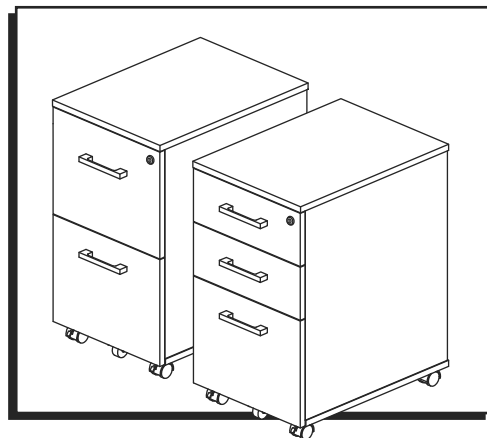
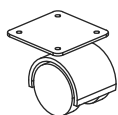
**PIÈCES****A**

Roulette non blocable x 2

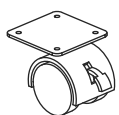
B

Roulette blocable x 2

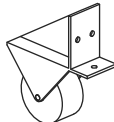
C

Roulette de tiroir x 1

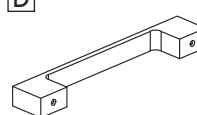
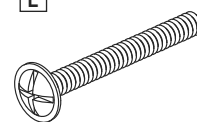
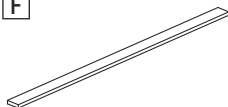
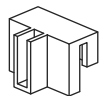
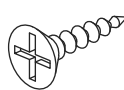
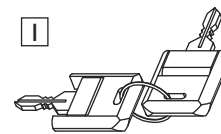
DPoignée x 2
(x 3 pour H-9785)**E**Vis M4 x 34 mm x 4
(x 6 pour H-9785)**F**Barre métallique x 1
(x 2 pour H-9784)**G**Attache pour classeur x 2
(x 4 pour H-9784)**H**Vis autotaraudeuse de
3,5 x 14 mm x 19**I**

Clés (jeu de 2) x 1

MONTAGE

Figure 1

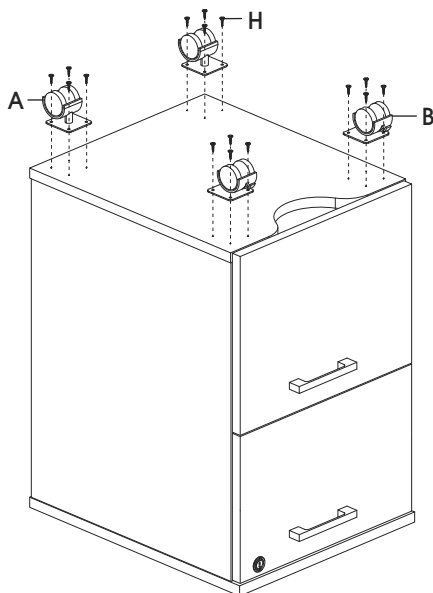
**REMARQUE :** Montez le classeur sur une surface lisse qui ne marque pas afin d'éviter les rayures.**REMARQUE :** Vérifiez que toutes les pièces sont incluses.**REMARQUE :** Serrez toutes les vis avec le tournevis cruziforme.

1. Retirez les roulettes et le matériel de montage des tiroirs.
2. Verrouillez les tiroirs avec une clé et retournez le classeur. Alignez les trous des roulettes blocables (B) sur les trous prépercés près de la face avant du classeur. Fixez-les avec huit vis autotaraudeuses de 3,5 x 14 mm (H). (Voir Figure 1)
3. Alignez les trous des roulettes non blocables (A) sur les trous prépercés près de la face arrière du classeur. Fixez-les avec huit vis autotaraudeuses de 3,5 x 14 mm (H). (Voir Figure 1)

MONTAGE SUITE

Figure 2

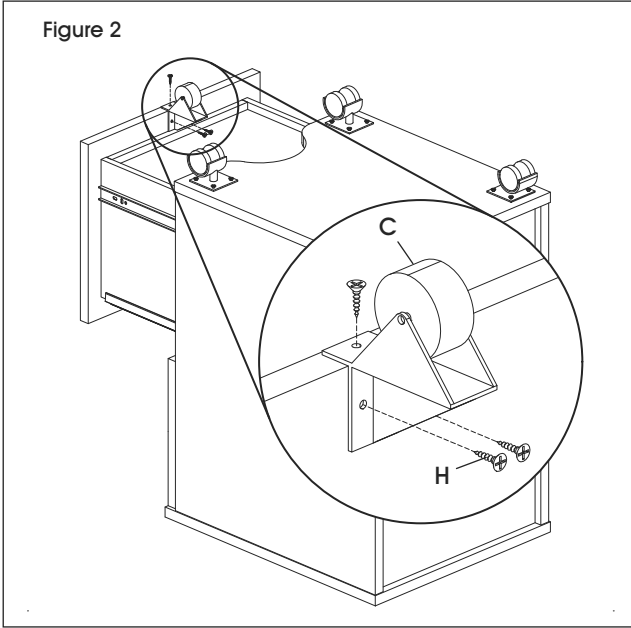

4. Déverrouillez les tiroirs et retirez lentement le tiroir inférieur. Fixez la roulette de tiroir (C) au dessous du tiroir inférieur avec trois vis autotaraudeuses de 3,5 x 14 mm (H) et la perceuse. (Voir Figure 2)

Figure 3

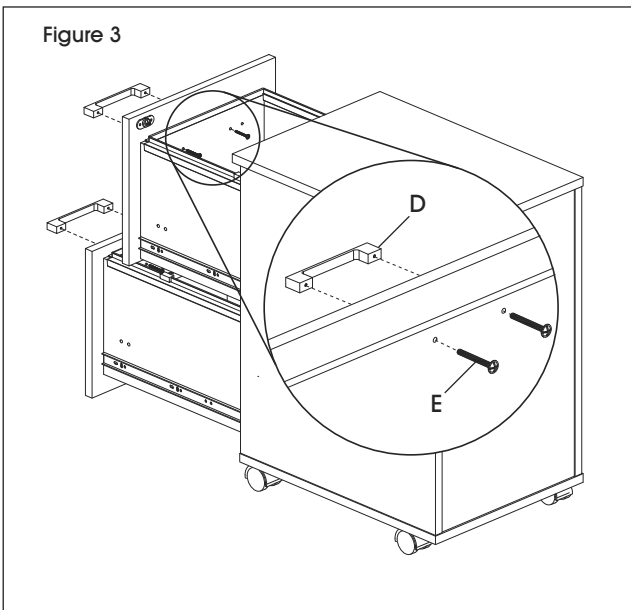

5. Placez le classeur à caisson à l'endroit. Enlevez et sortez les poignées préfixées (D) se trouvant dans le tiroir. Alignez les trous du tiroir sur ceux de la poignée et fixez-la avec deux vis M4 x 34 mm (E). Répétez cette étape pour l'/les autre(s) tiroir(s). (Voir Figure 3)

Figure 4

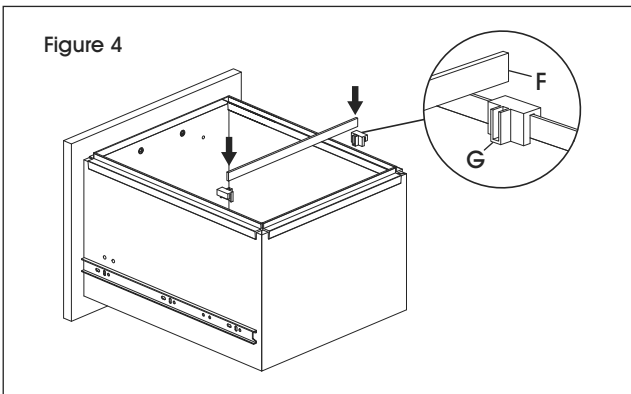

6. Fixez les attaches pour classeur (G) de chaque côté du/des tiroir(s), puis insérez la barre métallique (F). (Voir Figure 4)

ULINE

1-800-295-5510
uline.ca