

ULINE H-9790, H-9795, H-9800
H-10260, H-10261, H-10262

1-800-295-5510
uline.com

DESIGNER COLLECTION

OFFICE DESK

TOOLS NEEDED

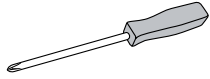

Phillips
Screwdriver



Allen Wrench
(Included)



Drill
(Optional)



Two Person Assembly
Recommended

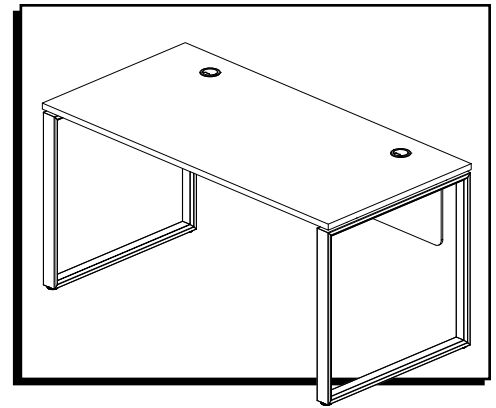

HARDWARE

A

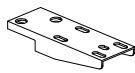

Desktop Bracket x 4

B

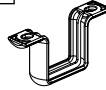

U-Bracket x 2

C

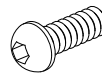

M6 x 20 mm Bolt x 14

D



M6 x 15 mm Screw x 28

E

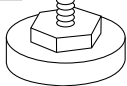

Floor Glide x 4

F



Grommet Cap x 2

G

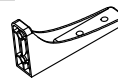

L-Bracket x 2

H

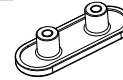

L-Bracket Cover x 2

PARTS

DESK

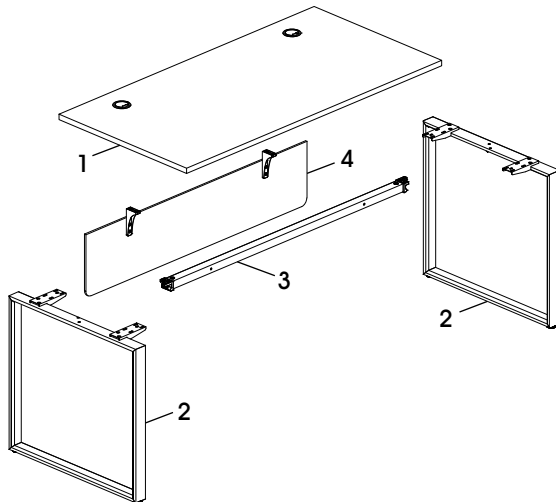

DESK PARTS

#	DESCRIPTION	QTY.
1	Desktop Panel	1
2	Leg Frame	2
3	Support Bar	1
4	Modesty Panel	1



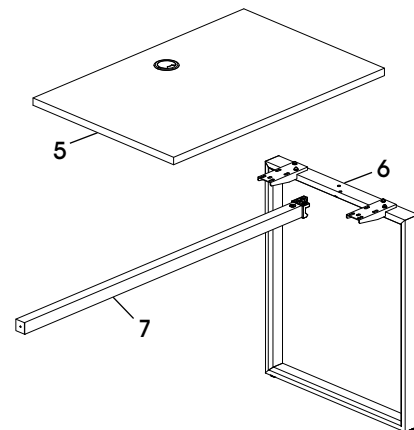

OPTIONAL L-DESK RETURN



OPTIONAL L-DESK RETURN PARTS

#	DESCRIPTION	QTY.
5	Return Desktop Panel	1
6	Return Leg Frame	1
7	Return Support Bar	1

ASSEMBLY

-  **NOTE:** Assemble on smooth, non-marring surface to avoid scratching.
-  **NOTE:** Use Allen wrench to tighten bolts.
-  **NOTE:** Use Phillips screwdriver to tighten screws.
-  **NOTE:** Check that all parts are included.

1. Install floor glides (E) on leg frames (2). (See Figure 1)

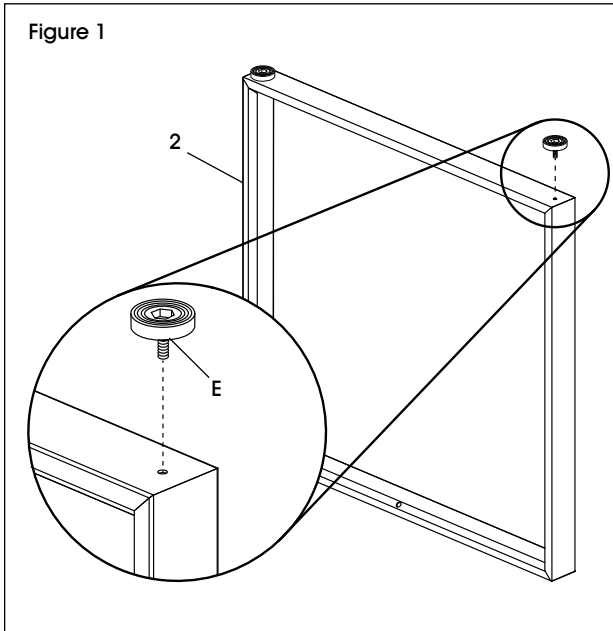

2. Align support bar (3) with holes on leg frames (2) and secure using three M6 x 20 mm bolts (C) on each side. (See Figure 2)

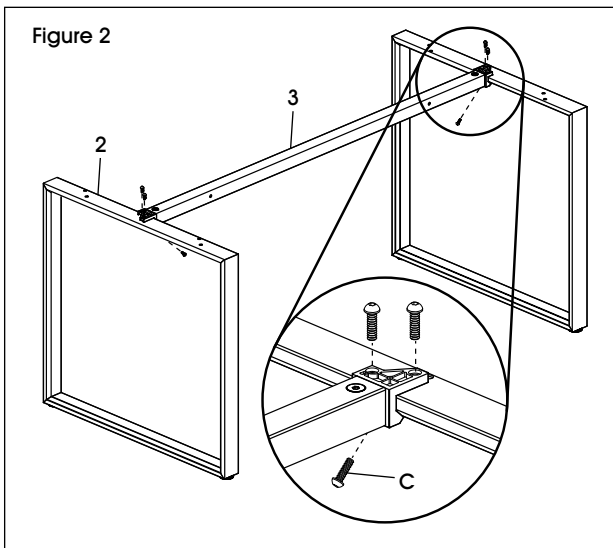

3. Attach four desktop brackets (A) to leg frames (2) using two M6 x 20 mm bolts (C) per bracket. (See Figure 3)

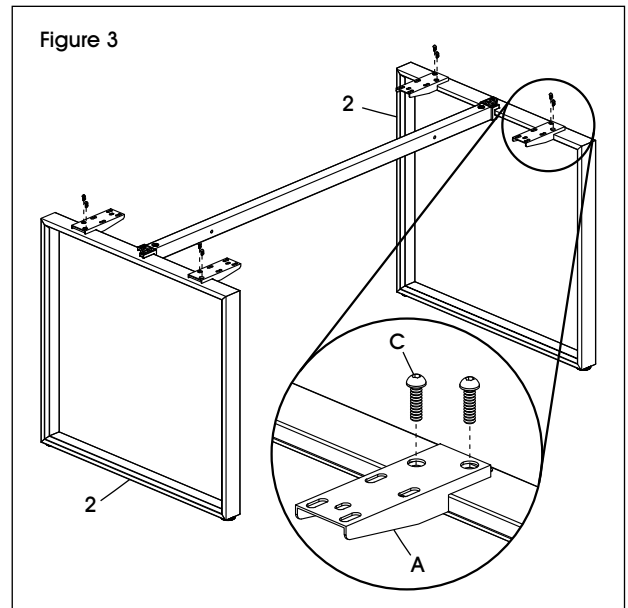

STOP To continue desk assembly, proceed to step 4. To continue L-desk assembly, proceed to L-Desk Return Assembly on page 4.

4. Place desktop panel (1) upside down with holes facing up. With second person, turn assembled desk frame upside down. Use four M6 x 15 mm screws (D) to secure each desktop bracket (A) to desktop panel. (See Figure 4)

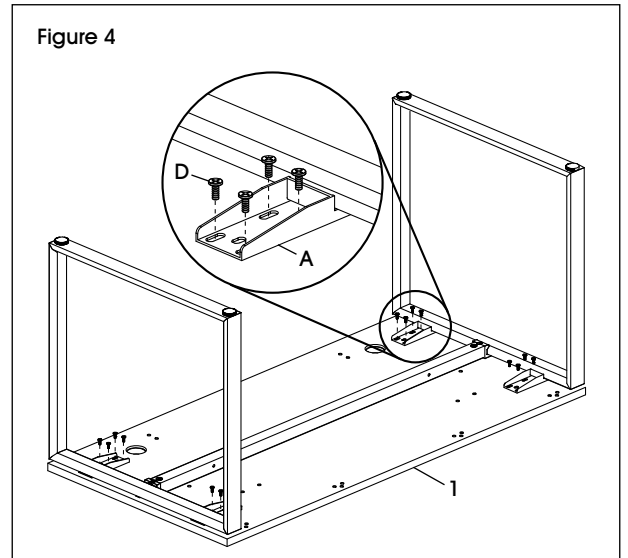

ASSEMBLY CONTINUED

5. Align U-brackets (B) with holes in desktop and use two M6 x 15 mm screws (D) to secure each bracket. (See Figure 5)

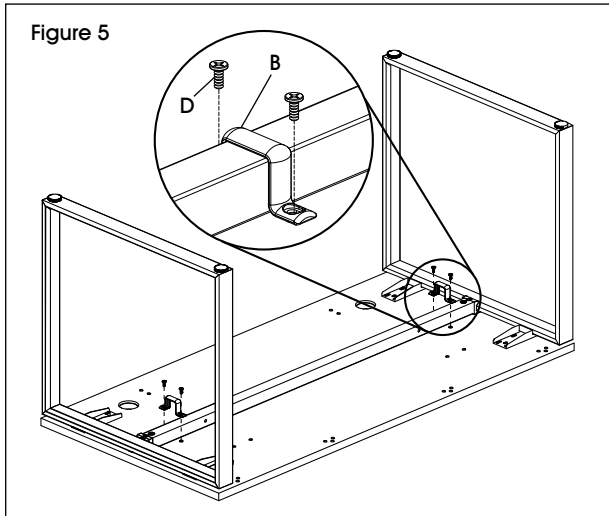

7. Align L-brackets (G) with holes in desktop panel (1) and use two M6 x 15 mm screws (D) to secure each bracket. (See Figure 7)

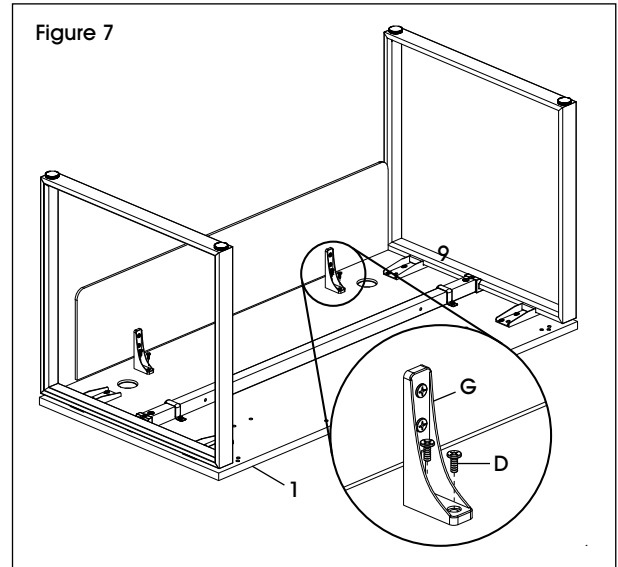

6. Align L-brackets (G) and L-bracket covers (H) with holes in modesty panel (4) and use two M6 x 15 mm screws (D) to secure each bracket and cover set. (See Figure 6)

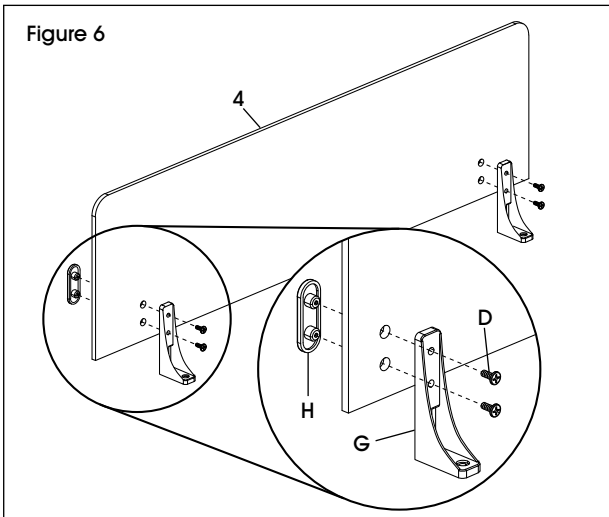

8. With second person, set desk upright. Insert grommet caps (F) into desktop. (See Figure 8)

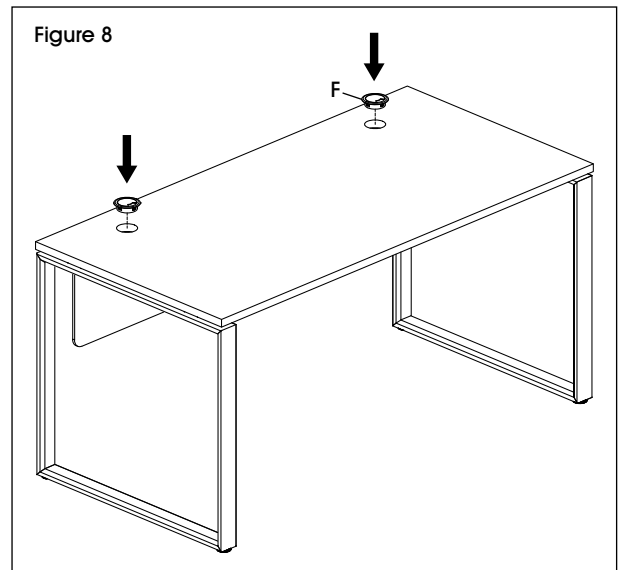

9. Adjust floor glides to compensate for uneven floors.

L-DESK RETURN PARTS

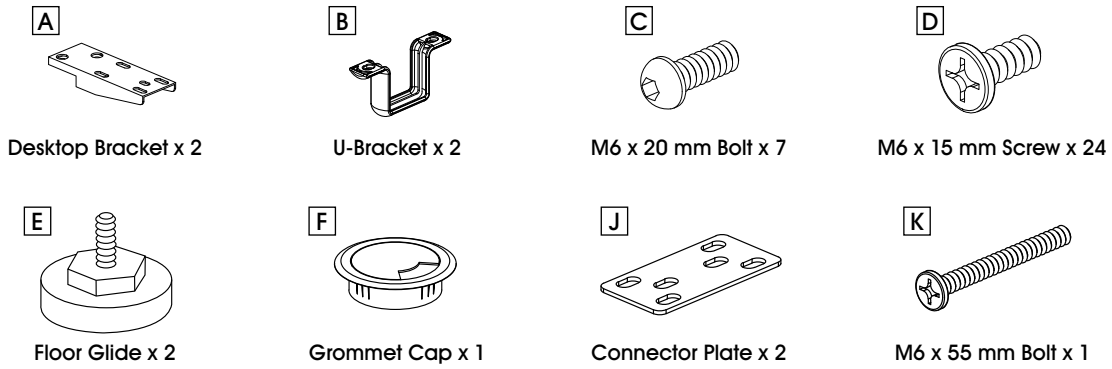

L-DESK RETURN ASSEMBLY

1. Install floor glides (E) on return leg frame (6).
(See Figure 9)

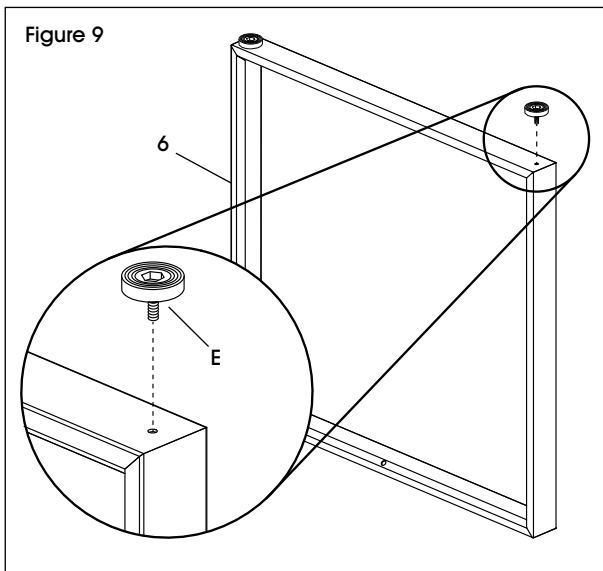

2. Align return support bar (7) with holes on return leg frame (6) and use three M6 x 20 mm bolts (C) to secure. (See Figure 10)

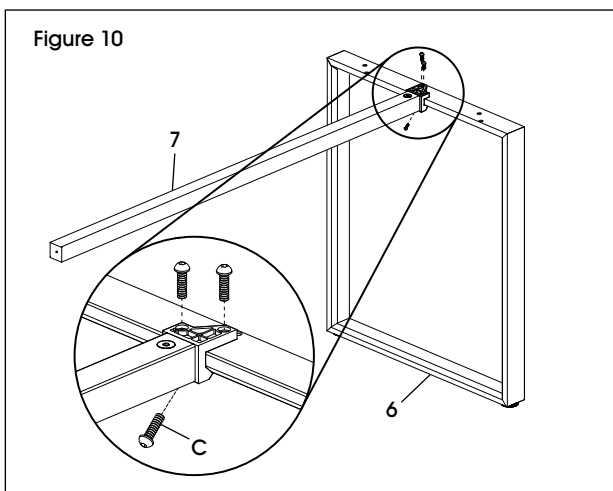

3. Attach two desktop brackets (A) to return leg frame (6) using two M6 x 20 mm bolts (C) per bracket. (See Figure 11)

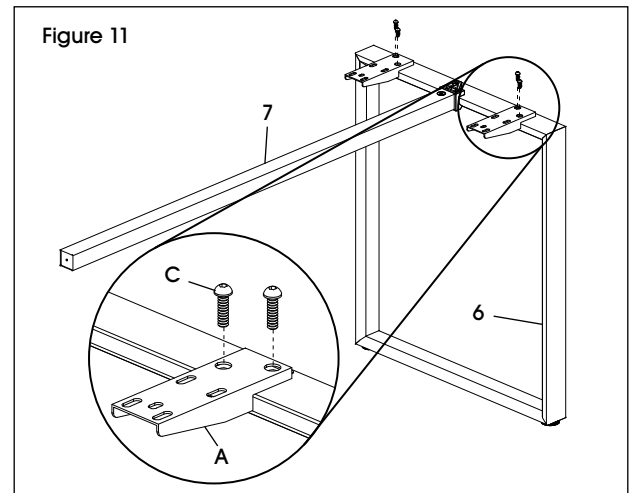

Determine whether L-desk will be set up for right-hand or left-hand configuration. This will impact how the return is assembled. Assembly of a right-hand L-desk is shown in the following figures. For left-hand L-desk configuration, attach return support bar (7) to left side of support bar (3).

L-DESK RETURN ASSEMBLY CONTINUED

- Align return support bar (7) with hole in main support bar (3). Use one M6 x 55 mm bolt (K) to secure. (See Figure 12)

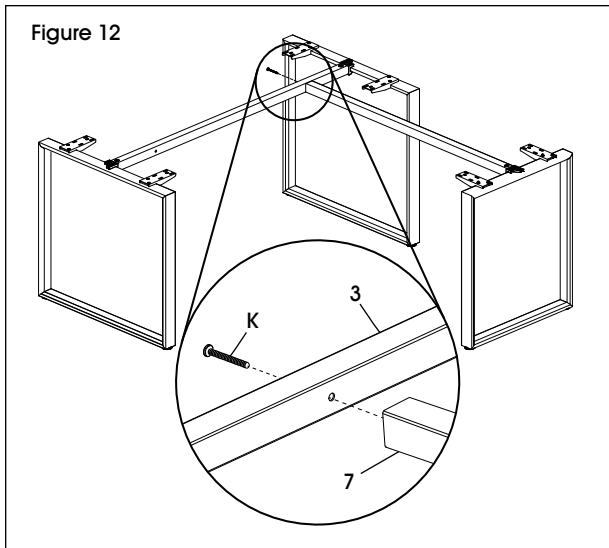

- Use four M6 x 15 mm screws (D) to secure each desktop bracket (A) to main desktop (1) and return desktop (5) panels. (See Figure 14)

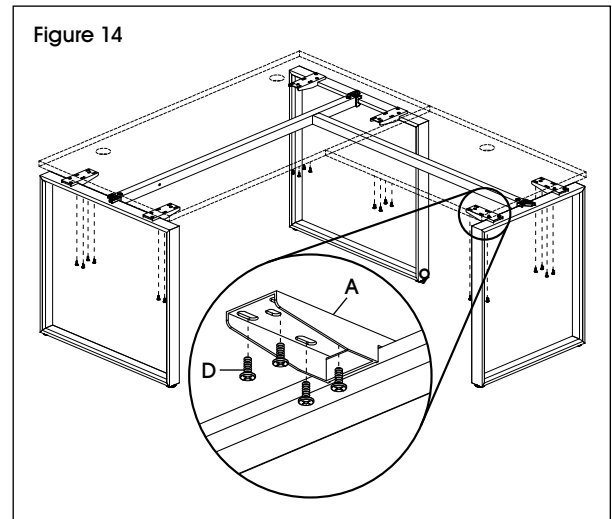

- With second person, set main desktop (1) and return desktop (5) panels on assembled frame. (See Figure 13)

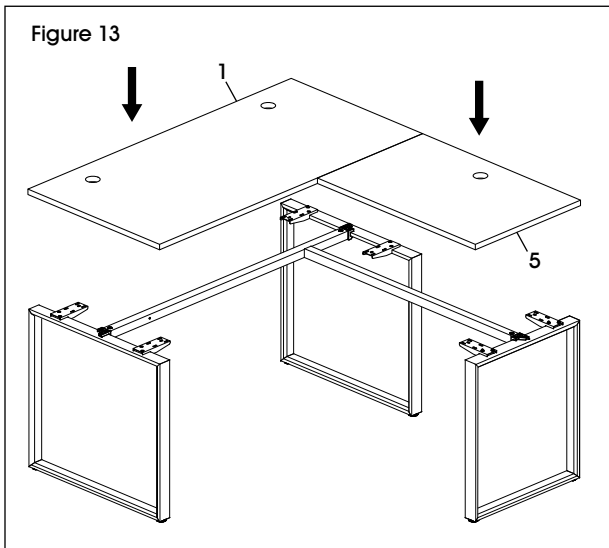

- Attach connector plates (J) to main desktop (1) and return desktop (5) panels with six M6 x 15 mm screws (D) per plate. (See Figure 15)

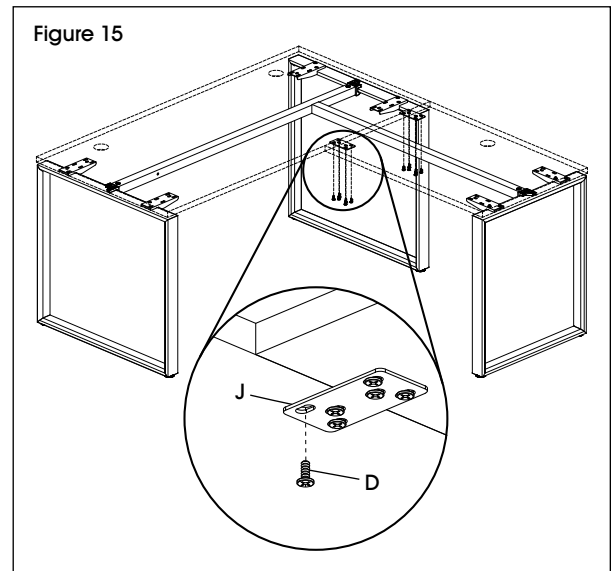

L-DESK RETURN ASSEMBLY CONTINUED

8. Align U-brackets (B) with holes in desktop (1) and return desktop using two M6 x 15 mm screws (D) to secure each bracket. (See Figure 16)

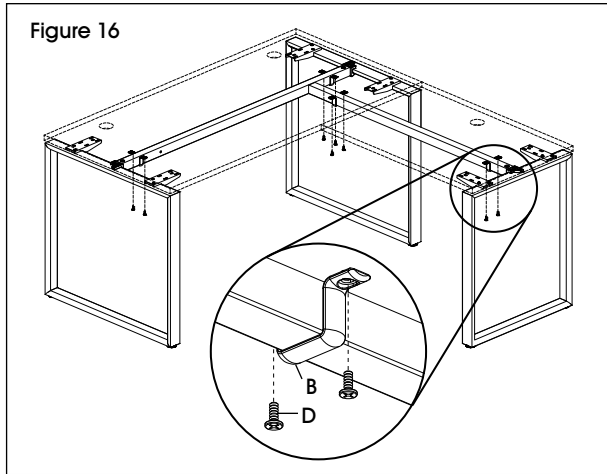

9. Align L-brackets (G) and L-bracket covers (H) with holes in modesty panel (4) and use two M6 x 15 mm screws (D) to secure each bracket and cover set. (See Figure 17)

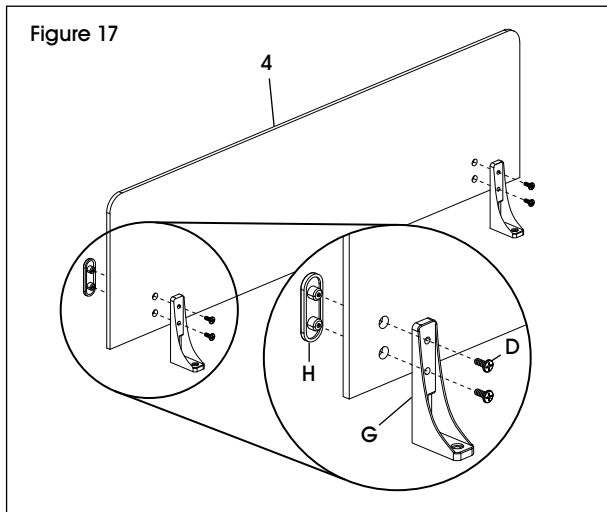

10. Align L-brackets (G) with holes in desktop panel (1) and use two M6 x 15 mm screws (D) to secure each bracket. (See Figure 18)

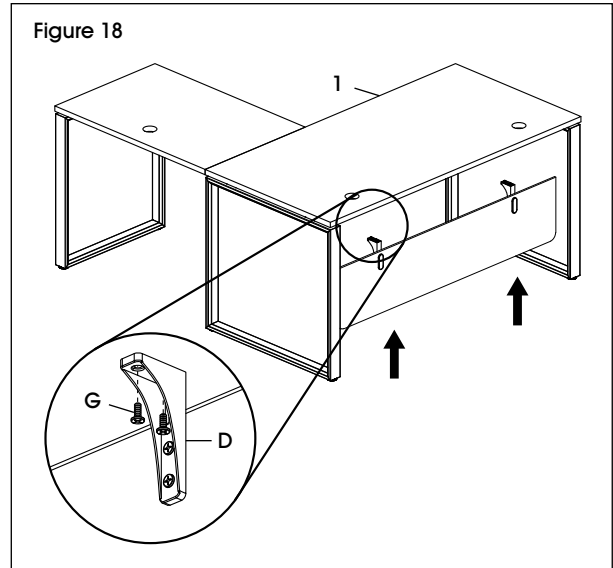

11. Insert grommet caps (F) into desktop. (See Figure 19)

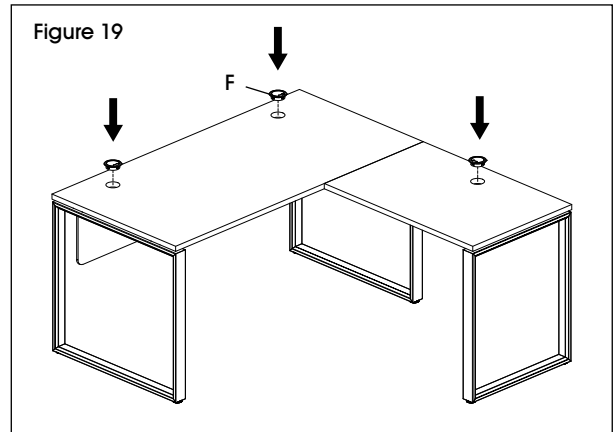

12. Adjust floor glides to compensate for uneven floors.

ULINE

1-800-295-5510
uline.com

COLECCIÓN DE DISEÑO

ESCRITORIO DE ACERO

HERRAMIENTAS NECESARIAS

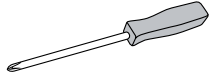

Desarmador de Cruz



Llave Allen (Incluida)



Taladro (Opcional)



Se Recomienda Armar Entre Dos Personas

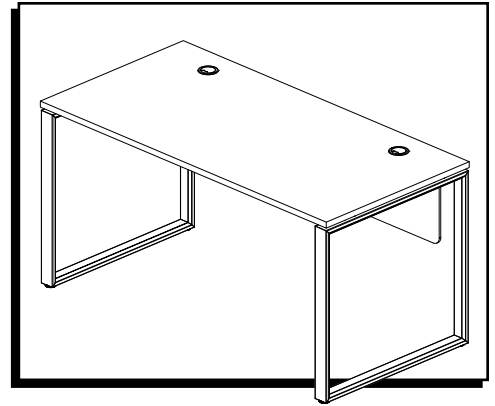

TORNILLERÍA

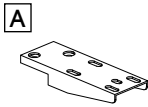

4 Soportes para Cubierta de Escritorio

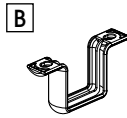

2 Soportes en U

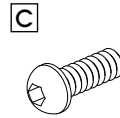

14 Pernos M6 x 20 mm

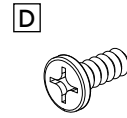

28 Tornillos M6 x 15 mm

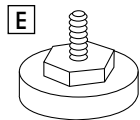

4 Tapas Niveladoras

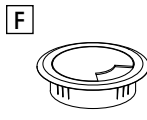

2 Tapas de Ojal

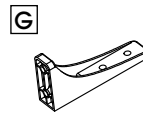

2 Soportes en L

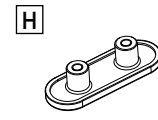

2 Cubiertas para Soporte en L

PARTES

ESCRITORIO

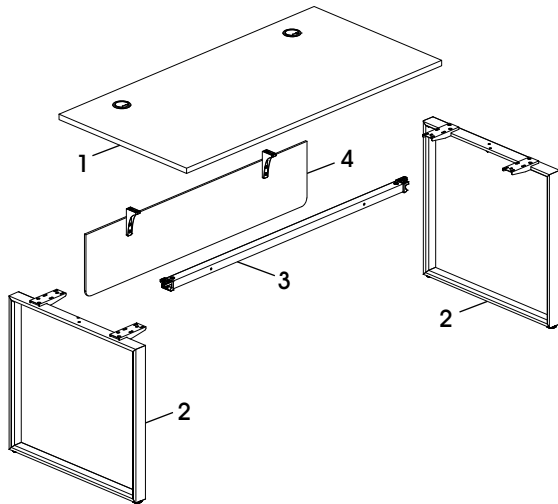

PARTES DEL ESCRITORIO

#	DESCRIPCIÓN	CANT.
1	Cubierta	1
2	Armazón de la Pata	2
3	Barra de Soporte	1
4	Recato	1

RETORNO OPCIONAL PARA ESCRITORIO EN L

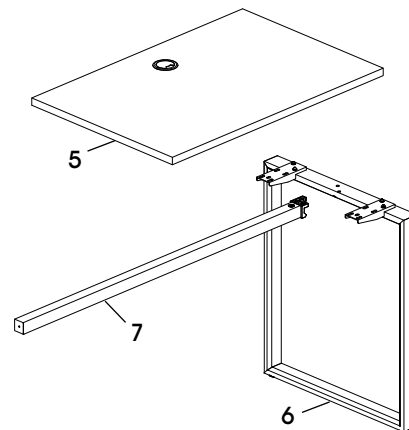

PARTES PARA RETORNO OPCIONAL PARA ESCRITORIO EN L

#	DESCRIPCIÓN	CANT.
5	Cubierta del Retorno para Escritorio	1
6	Armazón de la Pata para Retorno	1
7	Barra de Soporte para Retorno	1

ENSAMBLE

 **NOTA:** Ensamble sobre una superficie lisa que no deje marcas para evitar rayones.

 **NOTA:** Utilice la llave Allen para apretar todos los pernos.

 **NOTA:** Utilice un desarmador de cruz para apretar los tornillos.

 **NOTA:** Verifique que todas las partes estén incluidas.

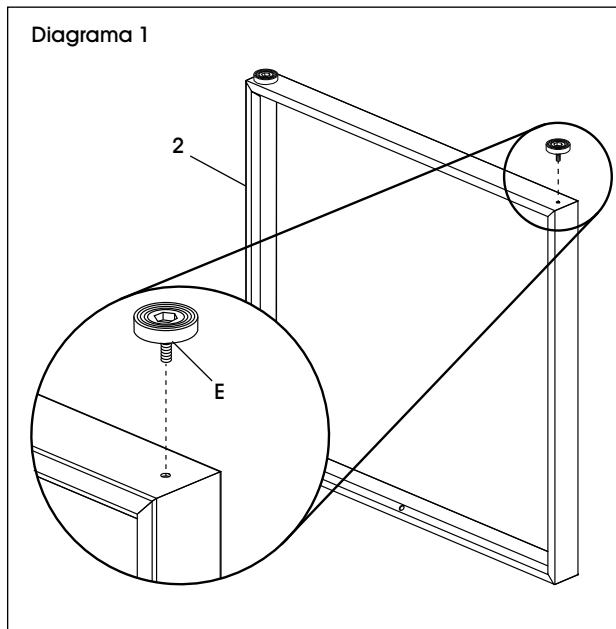

1. Instale las tapas niveladoras (E) en los armazones de las patas (2). (Vea Diagrama 1)
2. Alinee la barra de soporte (3) con los orificios de los armazones de las patas (2) y asegure usando tres pernos M6 x 20 mm (C) en cada lado. (Vea Diagrama 2)

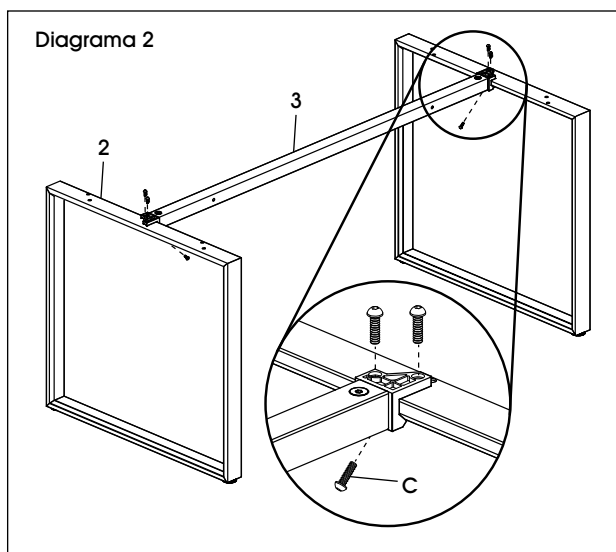

3. Fije cuatro soportes para cubierta de escritorio (A) a los armazones de las patas (2) usando dos pernos M6 x 20 mm (C) por soporte. (Vea Diagrama 3)

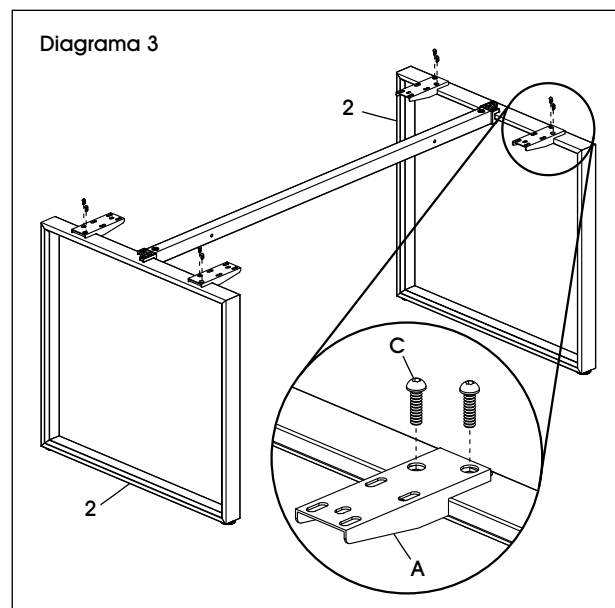

ALTO Para continuar el ensamblaje del escritorio proceda al Paso 4. Para continuar el ensamblaje del Escritorio en L, proceda al Ensamblaje del Retorno del Escritorio en L en la página 10.

4. Coloque la cubierta (1) boca abajo con los orificios hacia arriba. Con ayuda de otra persona, voltee el armazón ensamblado del escritorio. Use cuatro tornillos M6 x 15 mm (D) para asegurar cada soporte para cubierta de escritorio (A) a la cubierta. (Vea Diagrama 4)

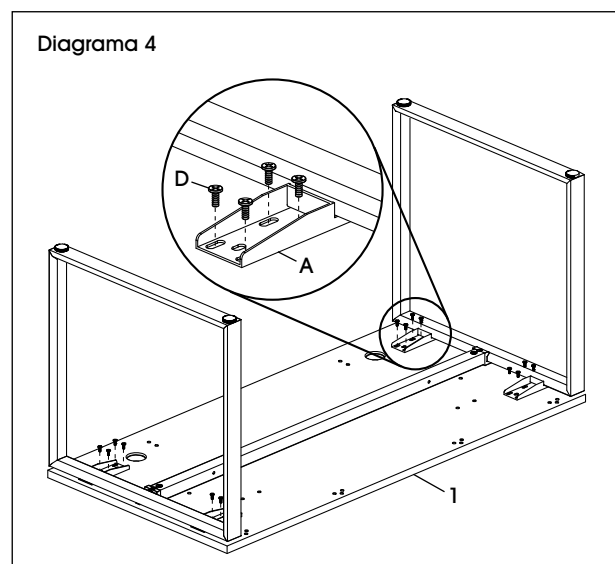

CONTINUACIÓN DEL ENSAMBLE

5. Alinee los soportes en U (B) con los orificios de la cubierta de escritorio y use dos tornillos M6 x 15 mm (D) para asegurar cada soporte. (Vea Diagrama 5)

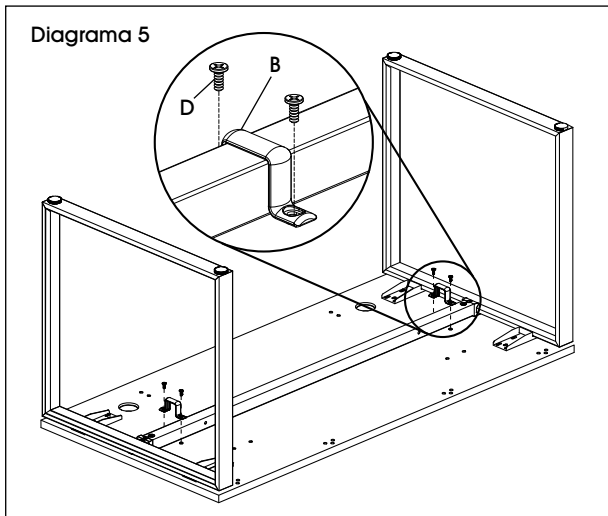

7. Alinee los soportes en L (G) con los orificios de la cubierta (1) y use dos tornillos M6 x 15 mm (D) para asegurar cada soporte. (Vea Diagrama 7)

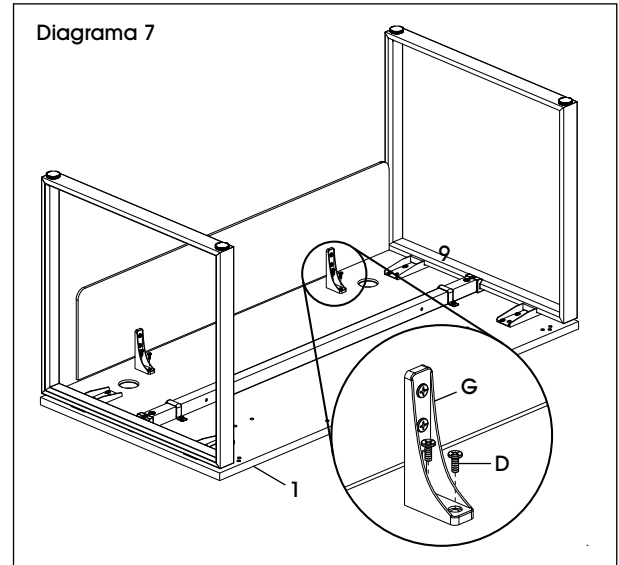

6. Alinee los soportes en L (G) y sus cubiertas (H) con orificios en el recato (4) y use dos tornillos M6 x 15 mm (D) para asegurar cada set de soporte y cubierta. (Vea Diagrama 6)

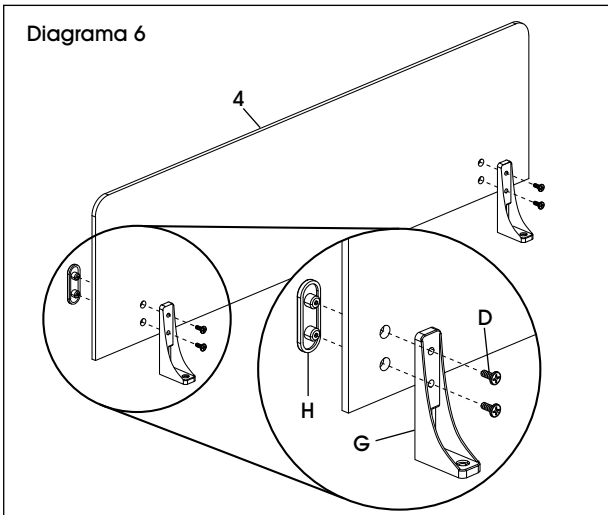

8. Con ayuda de otra persona, enderece el escritorio. Inserte las tapas de los ojales (F) en la cubierta del escritorio. (Vea Diagrama 8)

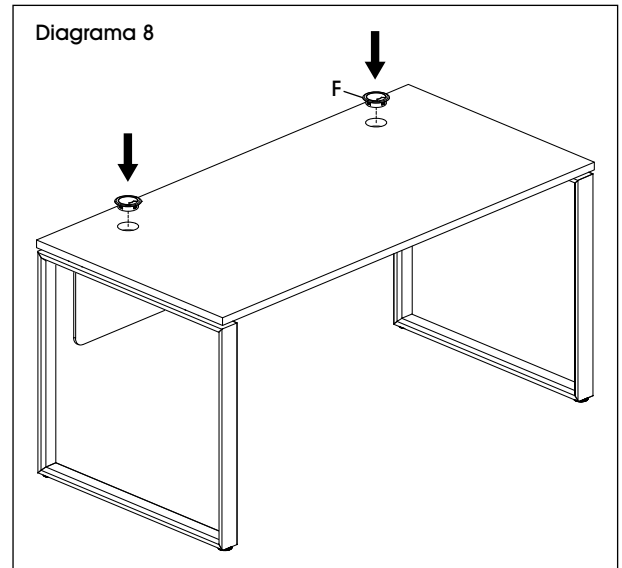

9. Ajuste las tapas niveladoras para compensar los pisos desnivelados.

PARTES DEL RETORNO PARA ESCRITORIO EN L

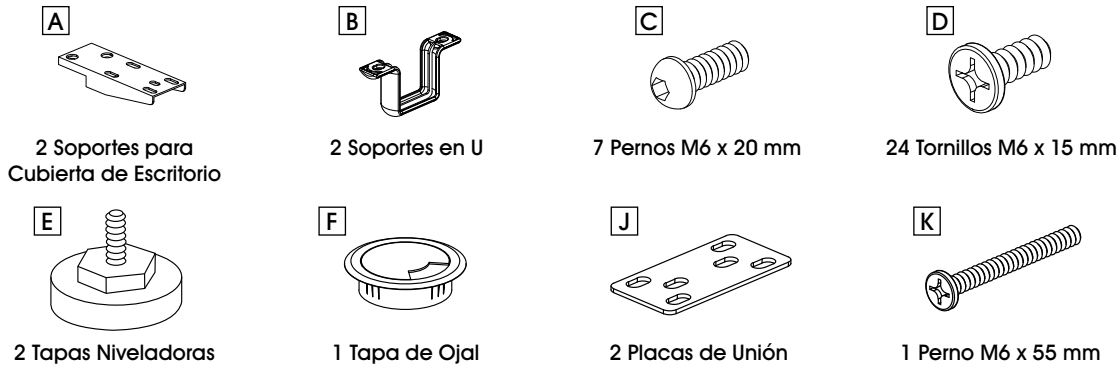

ENSAMBLE DEL RETORNO PARA ESCRITORIO EN L

1. Instale las tapas niveladoras (E) en el armazón de la pata para retorno (6). (Vea Diagrama 9)

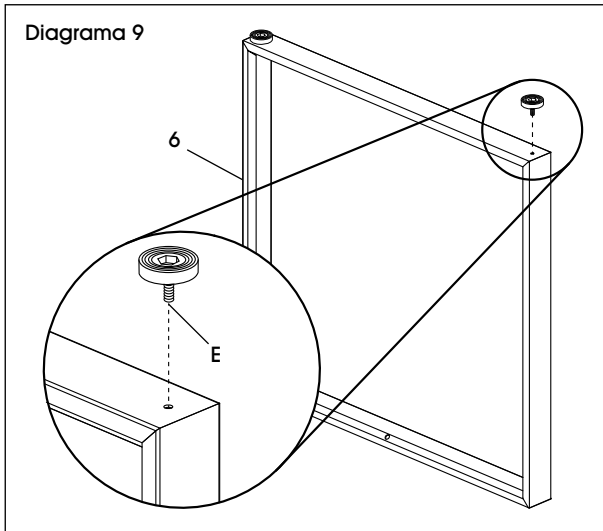

2. Alinee la barra de soporte para retorno (7) con los orificios del armazón de la pata para retorno (6) y use tres pernos M6 x 20 mm (C) en cada lado para asegurarla. (Vea Diagrama 10)

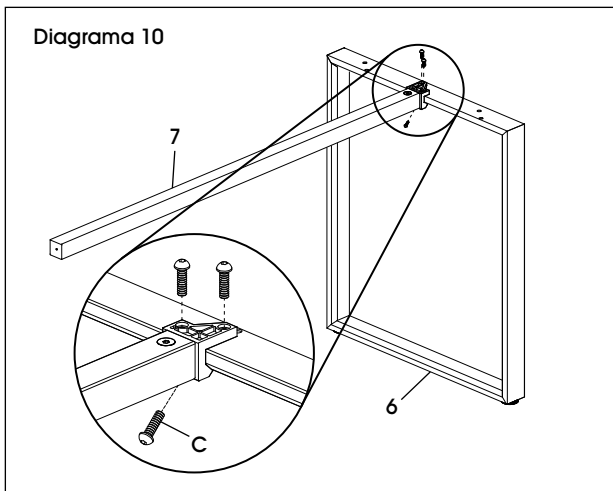

3. Fije dos soportes para cubierta de escritorio (A) al armazón de la pata para retorno (6) usando dos pernos M6 x 20 mm (C) por soporte. (Vea Diagrama 11)

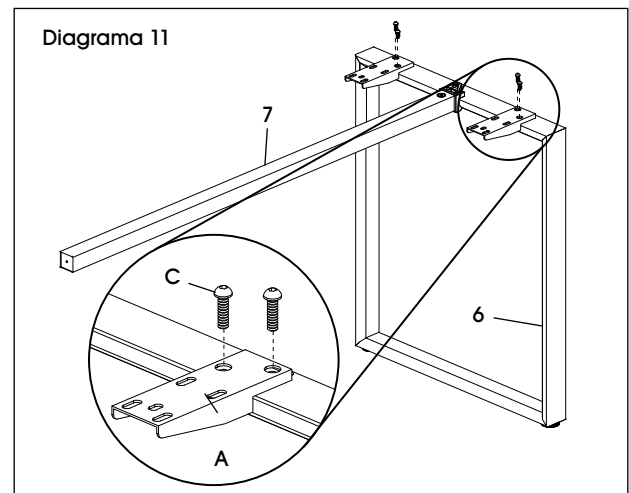

Determine si el escritorio L estará configurado para zurdos o diestros. Esto impactará el ensamble del retorno. Se muestra el ensamble de un escritorio en L para diestros en los siguientes diagramas. Para la configuración del escritorio en L para zurdos, fije la barra de soporte para retorno (7) al lado izquierdo de la barra de soporte.

CONTINUACIÓN DEL ENSAMBLE DEL RETORNO PARA ESCRITORIO EN L

4. Alinee la barra de soporte para retorno (7) con el orificio en la barra de soporte principal (3). Use un perno M6 x 55 mm (K) para asegurarla. (Vea Diagrama 12)

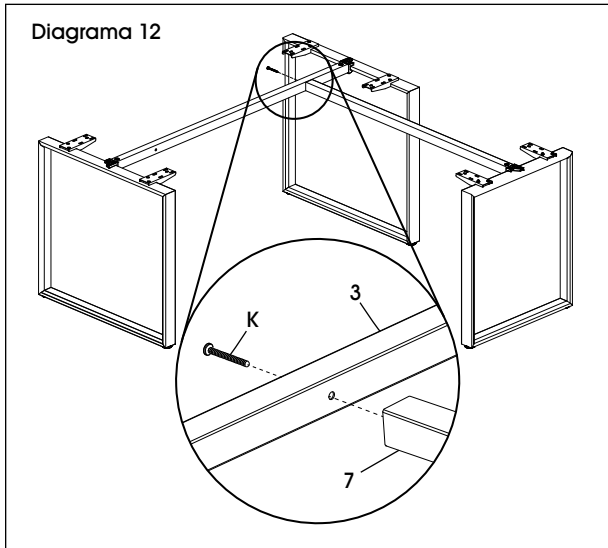

5. Con ayuda de otra persona, coloque la cubierta del escritorio principal (1) y la cubierta del retorno (5) sobre el armazón ensamblado. (Vea Diagrama 13)

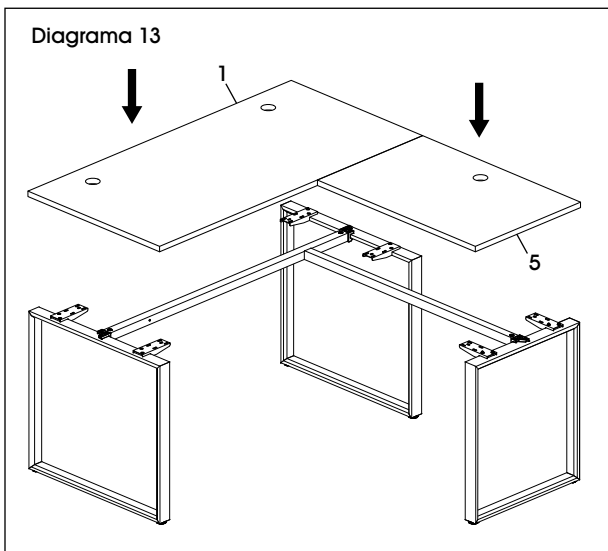

6. Use cuatro tornillos M6 x 15 mm (D) para asegurar cada soporte para cubierta de escritorio (A) a la cubierta de escritorio principal (1) y la cubierta del retorno (5). (Vea Diagrama 14)

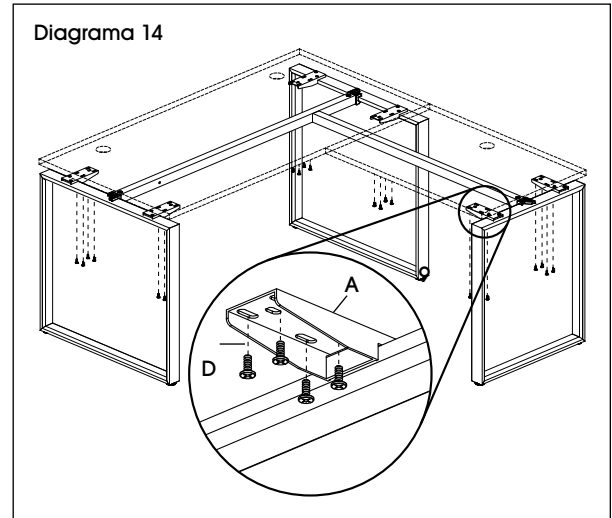

7. Fije las placas de unión (J) a la cubierta del escritorio principal (1) y la cubierta del retorno (5) con seis tornillos M6 x 15 mm (D) por placa. (Vea Diagrama 15)

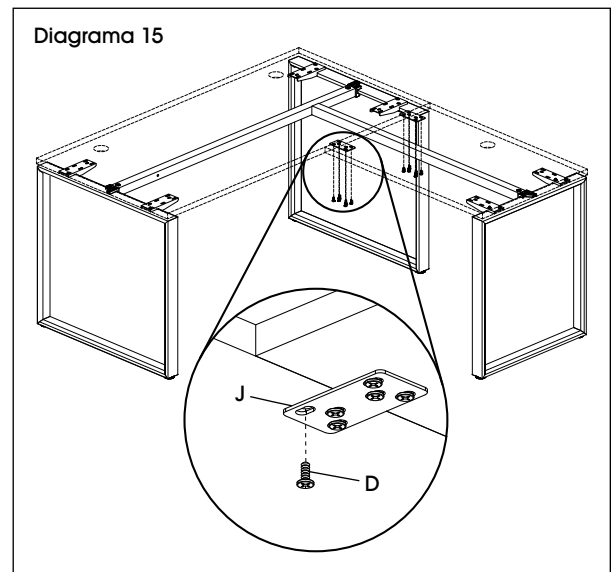

CONTINUACIÓN DEL ENSAMBLE DEL RETORNO PARA ESCRITORIO EN L

8. Alinee los soportes en U (B) con los orificios de la cubierta de escritorio (1) y la cubierta del retorno usando dos tornillos M6 x 15 mm (D) para asegurar cada soporte. (Vea Diagrama 16)

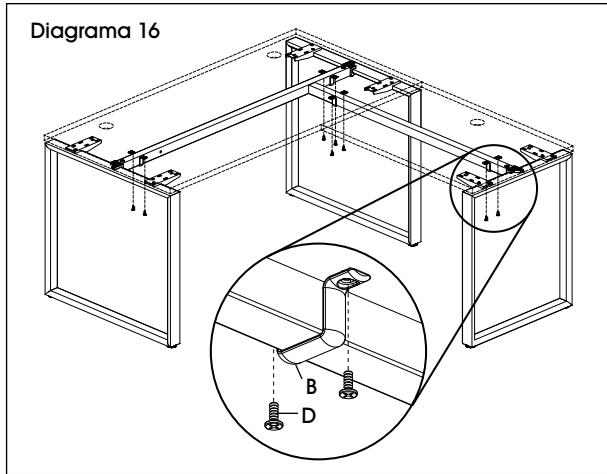

9. Alinee los soportes en L (G) y sus cubiertas (H) con orificios en el recato (4) y use dos tornillos M6 x 15 mm (D) para asegurar cada set de soporte y cubierta. (Vea Diagrama 17)

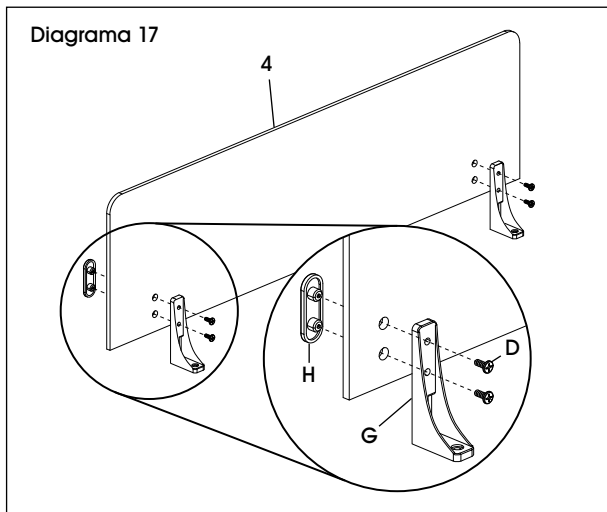

10. Alinee los soportes en L (G) con los orificios de la cubierta (1) y use dos tornillos M6 x 15 mm (D) para asegurar cada soporte. (Vea Diagrama 18)

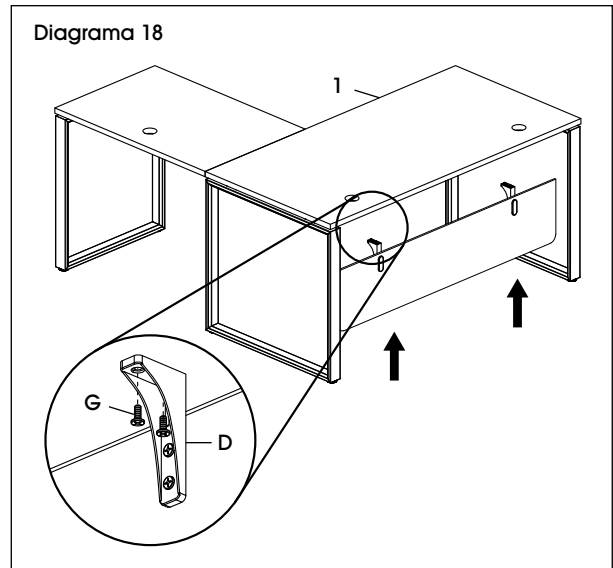

11. Inserte las tapas de los ojales (F) en la cubierta del escritorio. (Vea Diagrama 19)

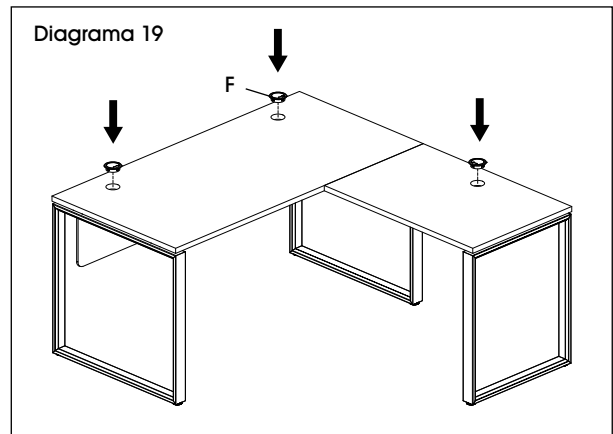

12. Ajuste las tapas niveladoras para compensar los pisos desnivelados.

ULINE

800-295-5510
uline.mx

COLLECTION DESIGNER

BUREAU EN ACIER

OUTILS REQUIS

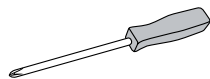

Tournevis cruciforme



Clé Allen
(inclus)



Perceuse
(optionnel)



Montage à deux
personnes recommandé

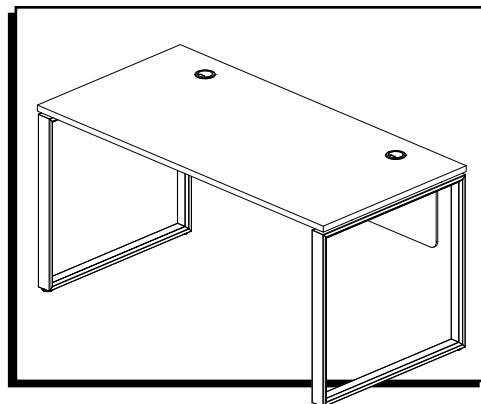

MATÉRIEL D'INSTALLATION

A

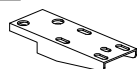

Support pour surface
de bureau x 4

B

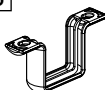

Support en U x 2

C

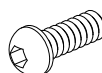

Boulon M6 x 20 mm x 14

D



Vis M6 x 15 mm x 28

E

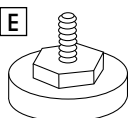

Patin de plancher x 4

F



Capuchon pour
passe-fil x 2

G



Support en L x 2

H

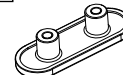

Cache pour
support en L x 2

PIÈCES

BUREAU

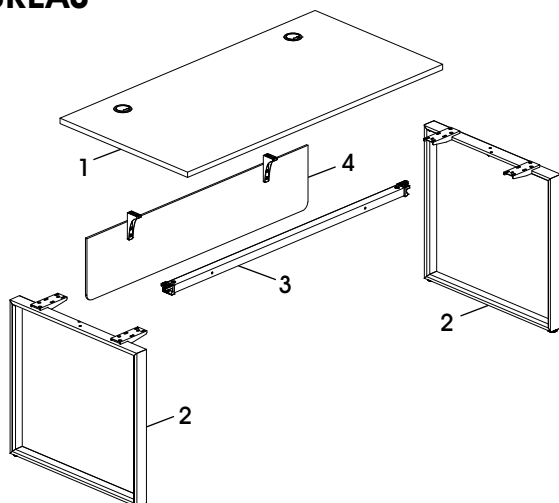

PIÈCES DE BUREAU

#	DESCRIPTION	QTÉ
1	Surface de bureau	1
2	Cadre de pied	2
3	Barre de support	1
4	Panneau cache-jambes	1

RETOUR DE BUREAU EN L OPTIONNEL

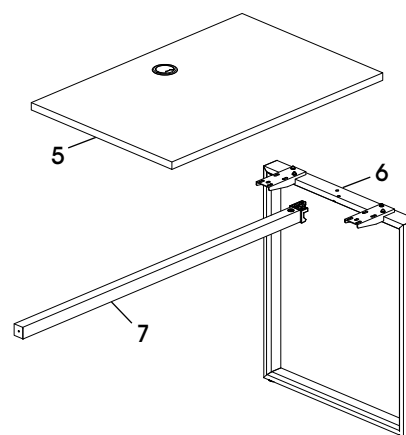

PIÈCES DU RETOUR DE BUREAU EN L OPTIONNEL

#	DESCRIPTION	QTÉ
5	Surface du retour de bureau	1
6	Cadre de pied du retour	1
7	Barre de support du retour	1

MONTAGE

 **REMARQUE :** Montez le bureau sur une surface lisse qui ne marque pas afin d'éviter les rayures.

 **REMARQUE :** Utilisez la clé Allen pour serrer les boulons.

 **REMARQUE :** Utilisez le tournevis cruciforme pour serrer les vis.

 **REMARQUE :** Vérifiez que toutes les pièces sont incluses.

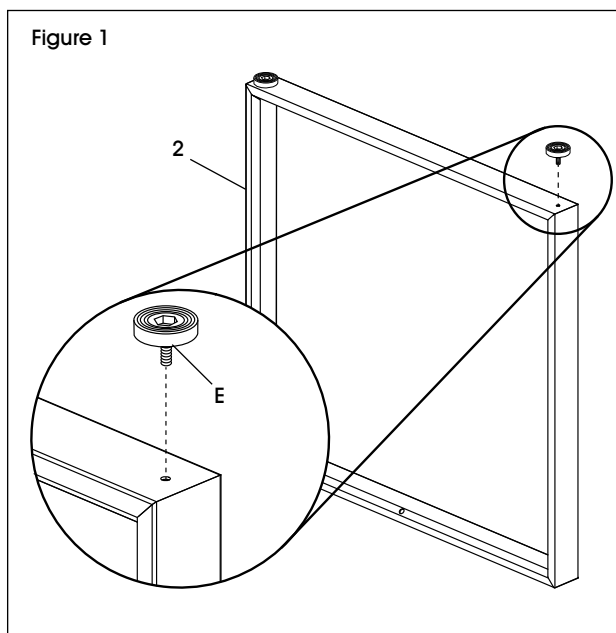

1. Installez les patins de plancher (E) sur les cadres de pied (2). (Voir Figure 1)
2. Alignez la barre de support (3) sur les trous des cadres de pied (2) et fixez-la sur chaque côté avec trois boulons M6 x 20 mm (C). (Voir Figure 2)

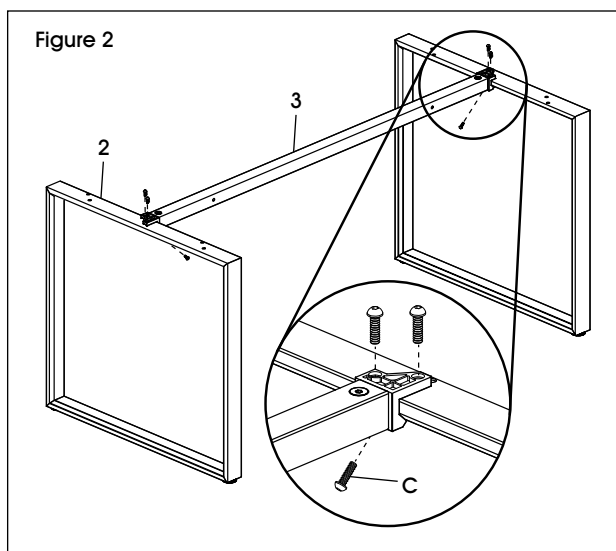

3. Fixez quatre supports pour surface de bureau (A) aux cadres de pied (2) avec deux boulons M6 x 20 mm (C) par support. (Voir Figure 3)

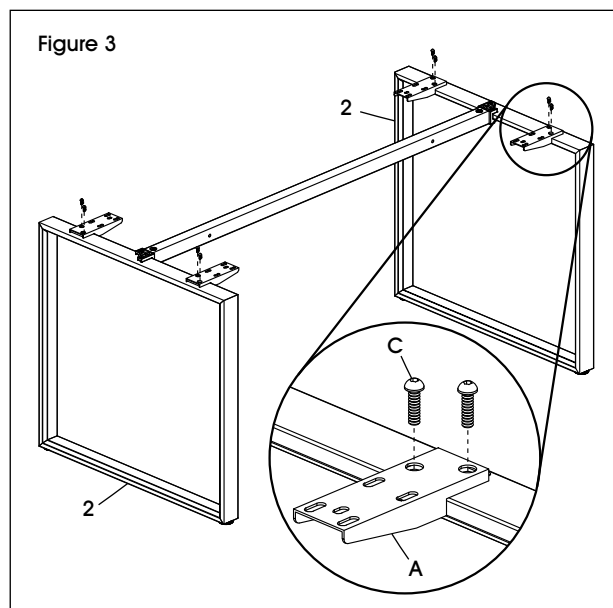

 **ARRÊT** Pour continuer le montage du bureau, passez à l'étape 4. Pour continuer le montage du bureau en L, passez au montage du retour de bureau en L à la page 16.

4. Placez la surface de bureau (1) à l'envers, avec les trous vers le haut. À deux, tournez le cadre de bureau monté à l'envers. Fixez chaque support pour surface (A) à la surface de bureau avec quatre vis M6 x 15 mm (D). (Voir Figure 4)

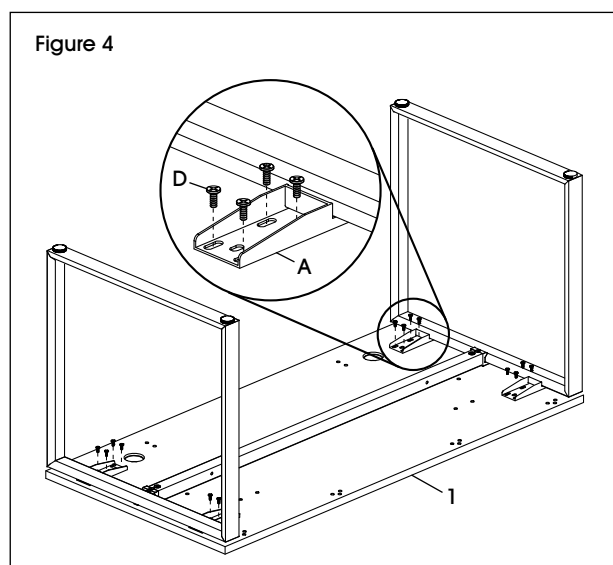

MONTAGE SUITE

5. Alignez les supports en U (B) sur les trous de la surface et fixez chaque support avec deux vis M6 x 15 mm (D). (Voir Figure 5)

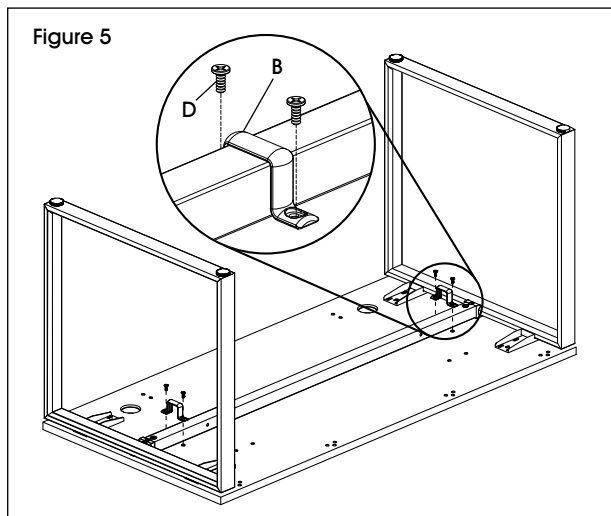

6. Alignez les supports en L (G) et les caches pour support en L (H) sur les trous du panneau cache-jambes (4) et fixez chaque support avec deux vis M6 x 15 mm (D) en les couvrant ensuite avec les caches. (Voir Figure 6)

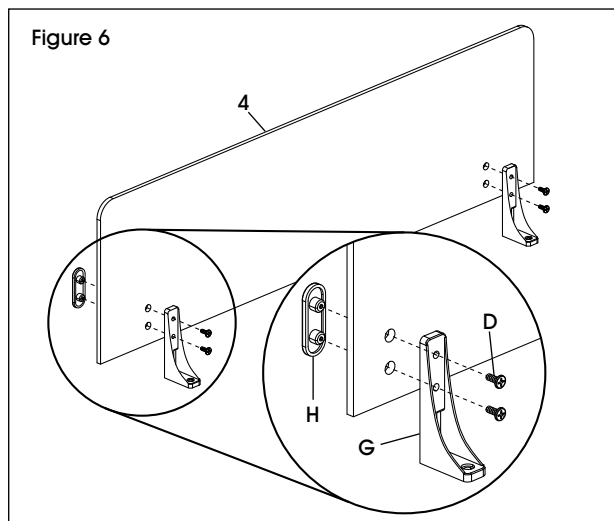

7. Alignez les supports en L (G) sur les trous de la surface de bureau (1) et fixez chaque support avec deux vis M6 x 15 mm (D). (Voir Figure 7)

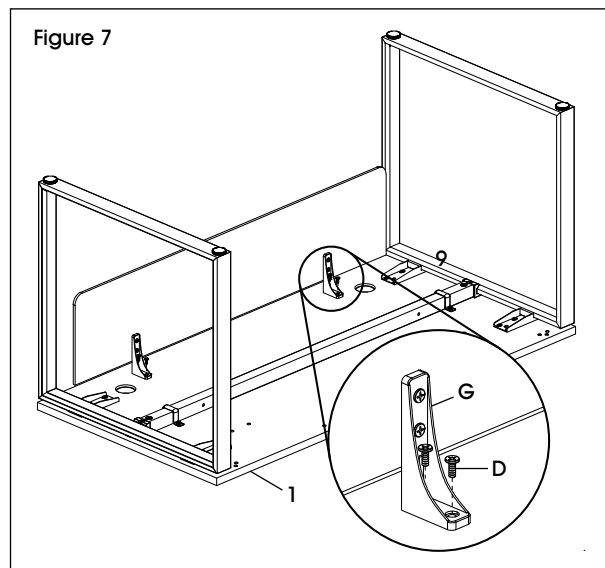

8. À deux, mettez le bureau à l'endroit. Insérez les capuchons pour passe-fil (F) dans la surface de bureau. (Voir Figure 8)

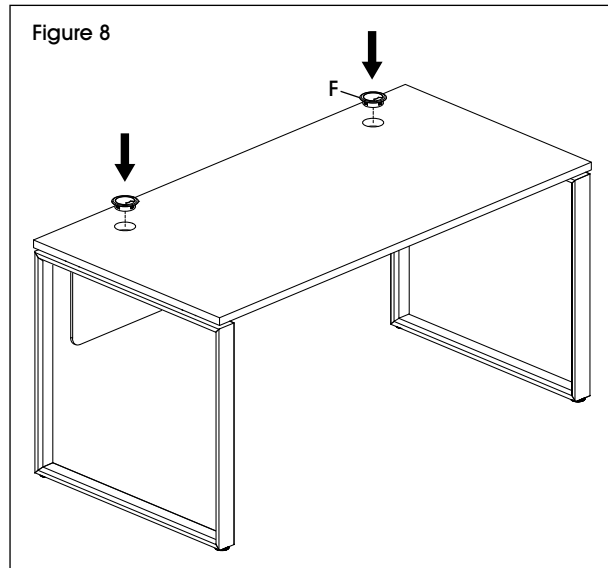

9. Ajustez les patins pour compenser les inégalités du sol.

PIÈCES DU RETOUR DE BUREAU EN L

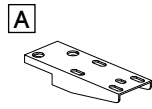

Support pour surface de bureau x 2

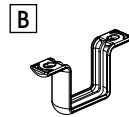

Support en U x 2

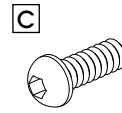

Boulon M6 x 20 mm x 7

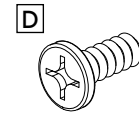

Vis M6 x 15 mm x 24

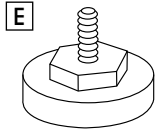

Patin de plancher x 2

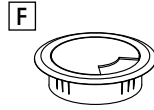

Capuchon pour passe-fil x 1

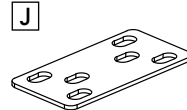

Plaque de connexion x 2

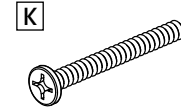

Boulon M6 x 55 mm x 1

MONTAGE DU RETOUR DE BUREAU EN L

1. Installez les patins de plancher (E) sur le cadre de pied du retour (6). (Voir Figure 9)

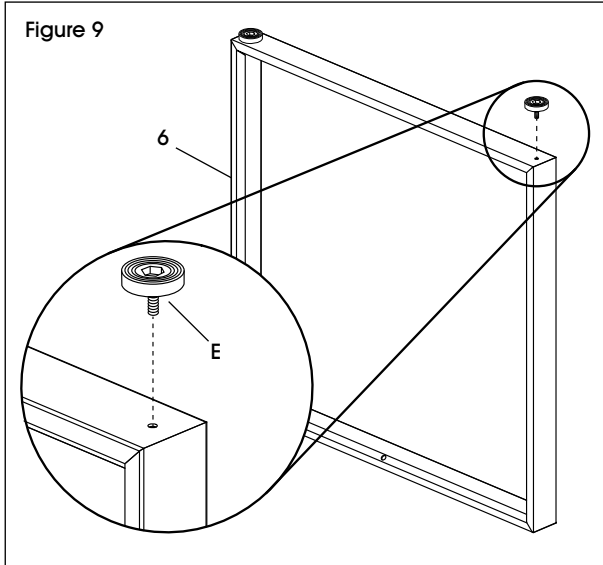

2. Alignez la barre de support du retour (7) sur les trous du cadre de pied du retour (6) et fixez-la avec trois boulons M6 x 20 mm (C). (Voir Figure 10)

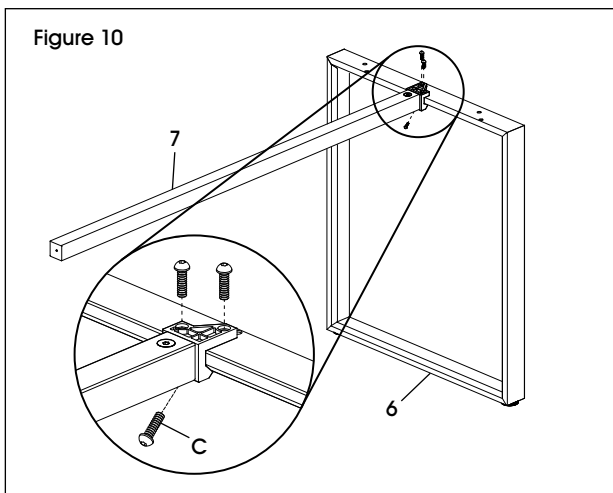

3. Fixez deux supports pour surface (A) au cadre de pied du retour (6) avec deux boulons M6 x 20 mm (C) par support. (Voir Figure 11)

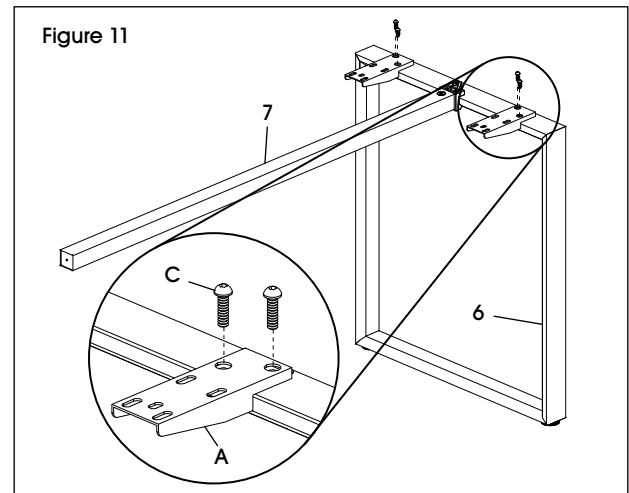

Déterminez si le bureau en L sera configuré à droite ou à gauche. Cela a un impact sur la façon dont le retour est assemblé. Le montage du bureau en L avec configuration à droite est indiqué dans les illustrations suivantes. Pour une configuration du bureau en L à gauche, fixez la barre de support du retour (7) sur le côté gauche de la barre de support (3).

MONTAGE DU RETOUR DE BUREAU EN L SUITE

4. Alignez la barre de support (7) sur le trou de la barre de support principale (3). Fixez-la avec un boulon M6 x 55 mm (K). (Voir Figure 12)

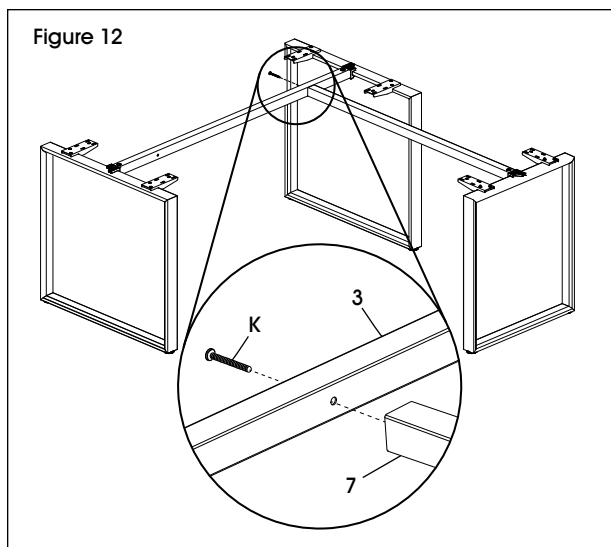

5. À deux, disposez la surface de bureau principale (1) et celle du retour (5) sur le cadre monté. (Voir Figure 13)

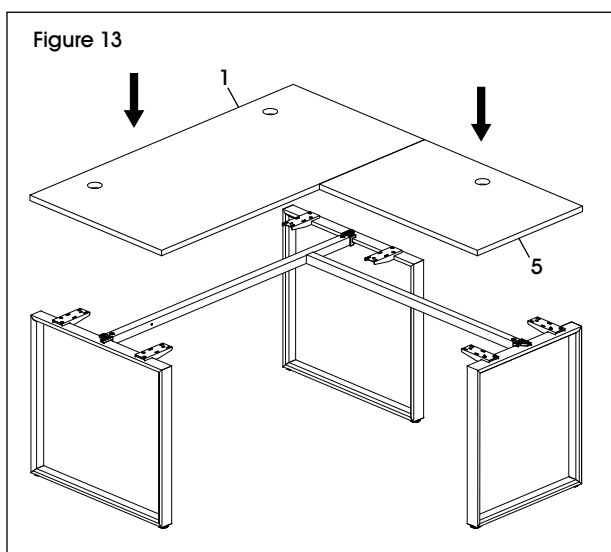

6. Fixez chaque support pour surface (A) à la surface de bureau principale (1) et à la cellule du retour (5) avec quatre vis M6 x 15 mm (D). (Voir Figure 14)

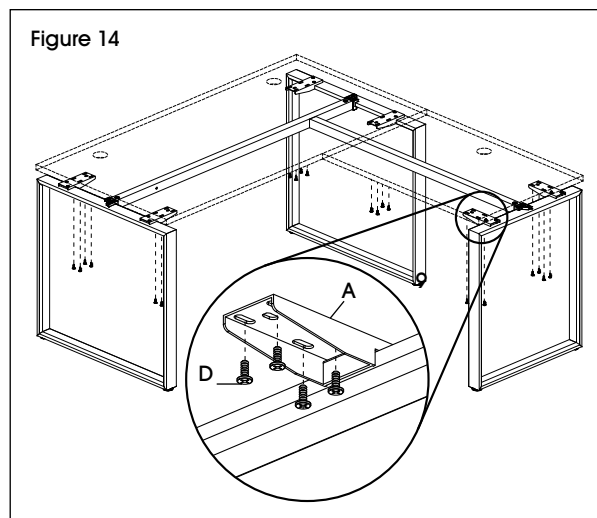

7. Fixez les plaques de connexion (J) à la surface de bureau principale (1) et à celle du retour (5) avec six vis M6 x 15 mm (D) par plaque. (Voir Figure 15)

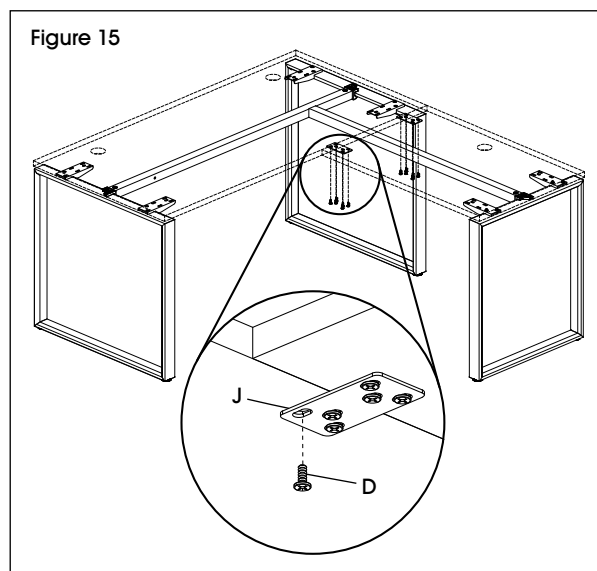

MONTAGE DU RETOUR DE BUREAU EN L SUITE

8. Alignez les supports en U (B) sur les trous de la surface de bureau principale (1) et celle du retour (5) et fixez chaque support avec deux vis M6 x 15 mm (D). (Voir Figure 16)

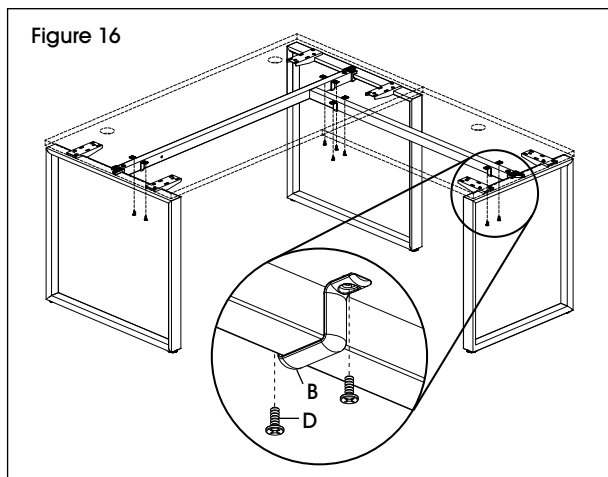

9. Alignez les supports en L (G) et les caches pour support en L (H) sur les trous du panneau cache-jambes (4) et fixez chaque support avec deux vis M6 x 15 mm (D) en les couvrant ensuite avec les caches. (Voir Figure 17)

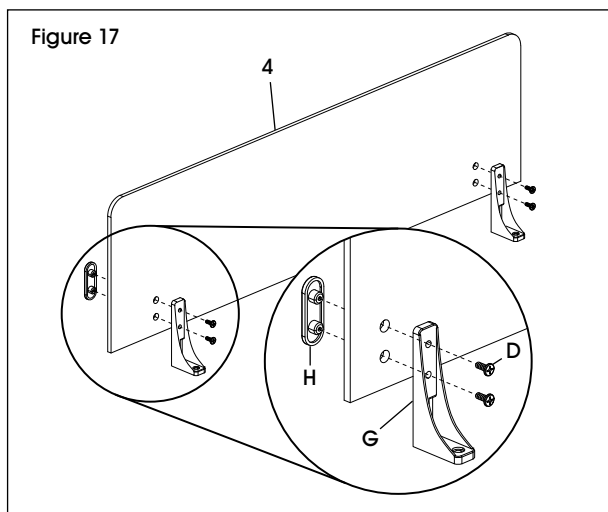

10. Alignez les supports en L (G) sur les trous de la surface de bureau (1) et fixez chaque support avec deux vis M6 x 15 mm (D). (Voir Figure 18)

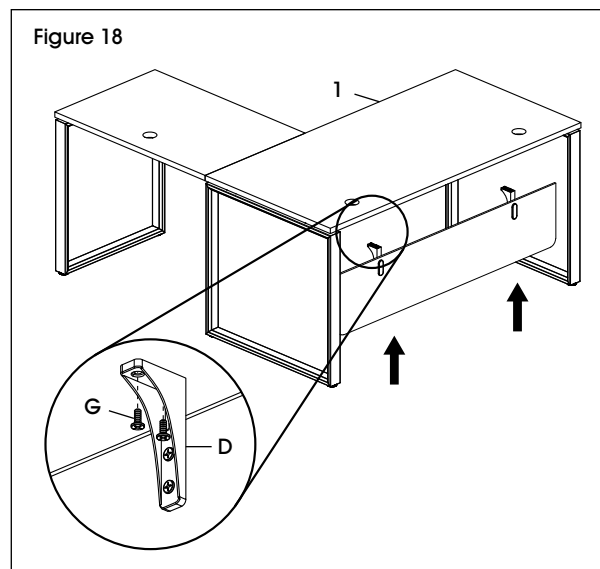

11. Insérez les capuchons pour passe-fil (F) dans la surface de bureau. (Voir Figure 19)

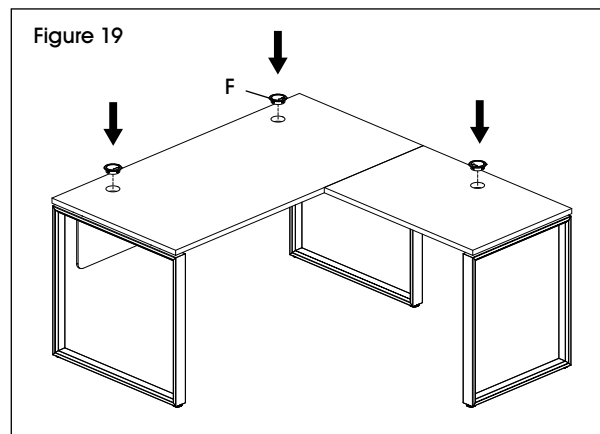

12. Ajustez les patins pour compenser les inégalités du sol.

ULINE

1-800-295-5510
uline.ca