

ULINE H-9839
EYEWASH CART

1-800-295-5510
 uline.com

Para Español, vea páginas 4-6.
 Pour le français, consulter les pages 7-9.

TOOLS NEEDED



13 mm Wrench



Adjustable Wrench

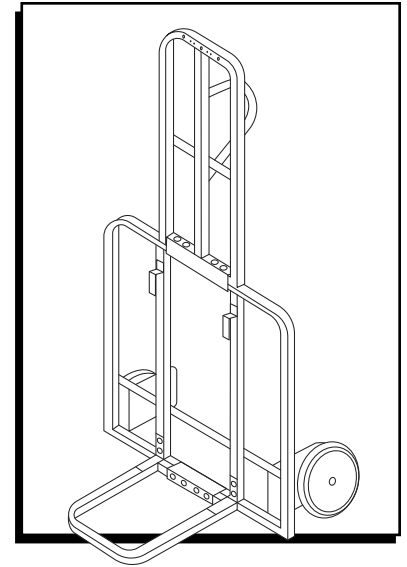

PARTS

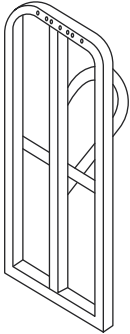

Upper Section x 1

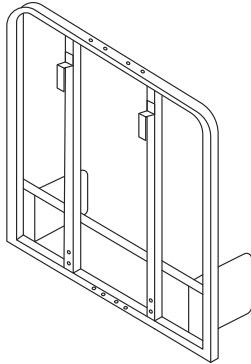

Lower Section x 1

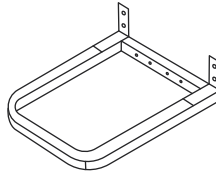

Base Section x 1

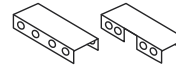

C-Bracket x 2



Cotter Pin x 2

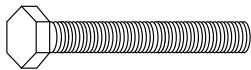

5/16 x 2 1/2" Hex Bolt x 8

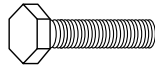

5/16 x 1 1/2" Hex Bolt x 4

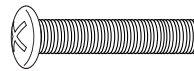

1/4 x 2" Phillips Head Bolt x 3



13 mm Locknut x 12



Wing Nut x 3



1/2" Flat Washer x 4

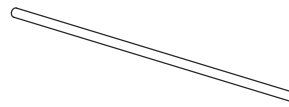

Axle x 1



Wheel x 2



5/16" Flat Washer x 15

ASSEMBLY



NOTE: Check that all parts are included.

1. Attach base section to lower section using one C-bracket and four 5/16 x 2 1/2" hex bolts. Secure bolts with four 5/16" flat washers and 13 mm locknuts. (See Figure 1)



NOTE: Bolt heads should face front of unit.
Do not tighten nuts at this point.

2. Secure base section to lower section by using four 5/16 x 1 1/2" hex bolts, 5/16" flat washers and 13 mm locknuts on L-brackets of base section. (See Figure 1)

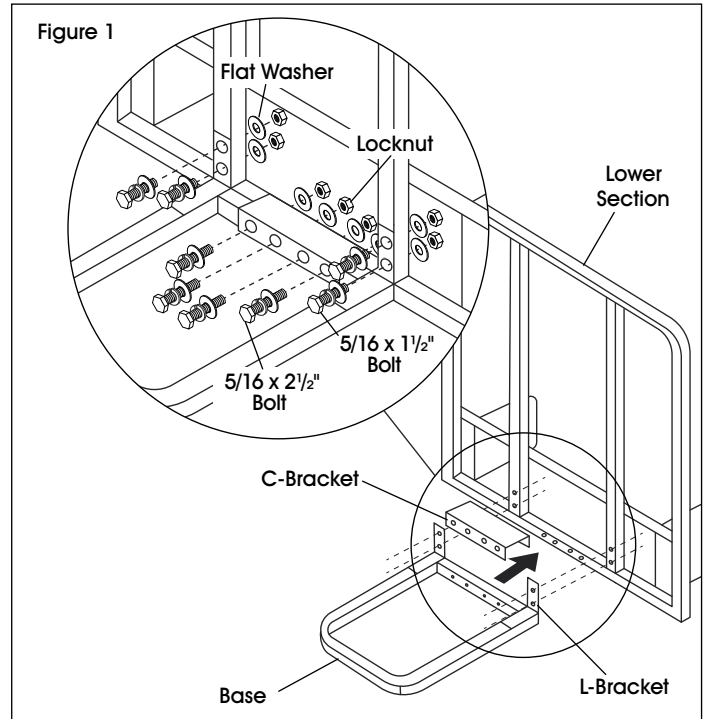

3. Attach upper section to lower section using remaining C-bracket and four 5/16 x 2 1/2" hex bolts. Secure bolts with four 5/16" flat washers and 13 mm locknuts. (See Figure 2)

4. Tighten all nuts.

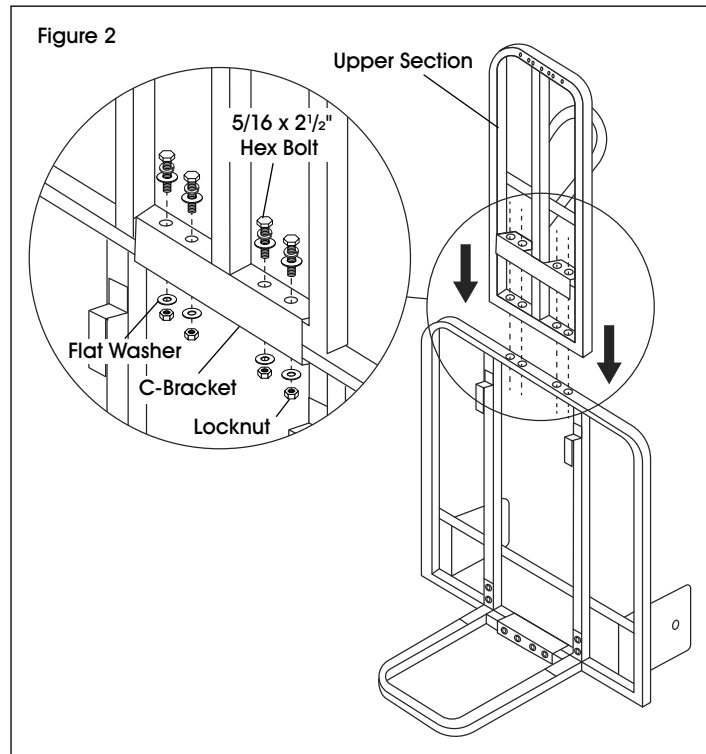

ASSEMBLY CONTINUED

- Slide axle through both axle support brackets.
- Install 1/2" flat washer, wheel and another 1/2" flat washer on one end of axle. Insert cotter pin through hole on the axle to secure wheel. Repeat on opposite side. (See Figure 3)

 **NOTE:** Wheel hubs should face axle support bracket.

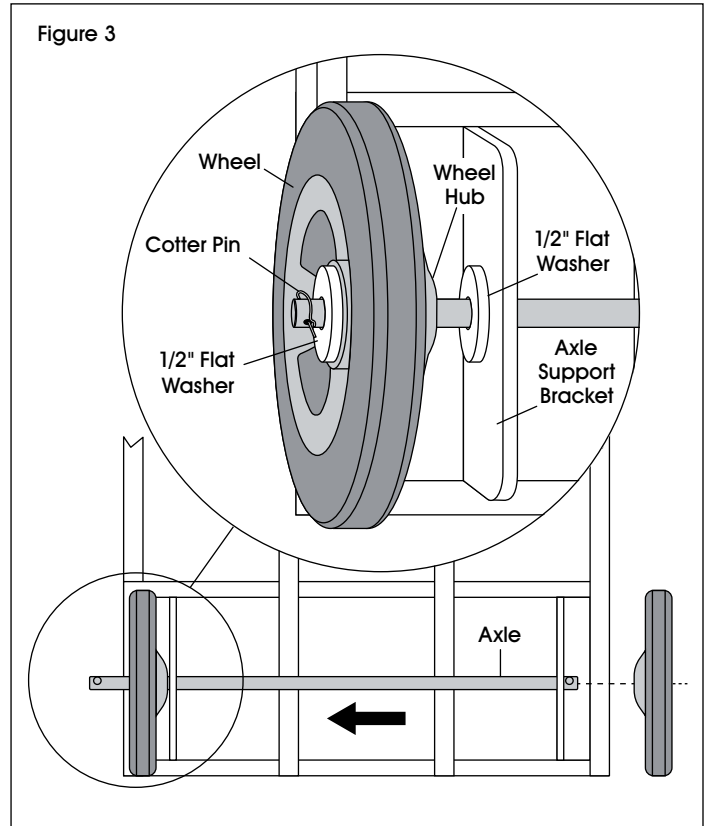

EYEWASH MOUNTING BRACKET ASSEMBLY

 **NOTE:** Eyewash mounting bracket is included with eyewash station.

 **NOTE:** Bracket may not match what is shown in Figure 4 and may only require two bolts.

- Mount bracket to mobile cart using 1/4 x 2" Phillips head bolts. Secure with 5/16" flat washers and wing nuts. (See Figure 4)

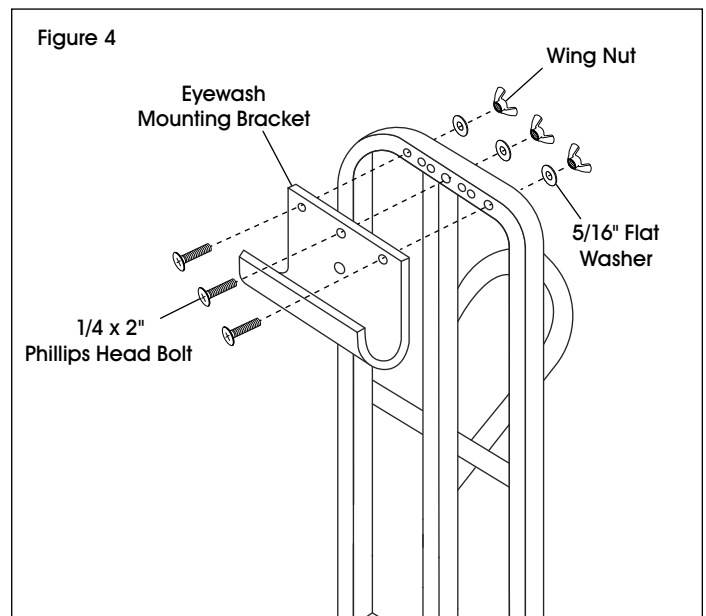

ULINE

1-800-295-5510
uline.com

ULINE H-9839
CARRITO LAVAOJOS

800-295-5510
 uline.mx

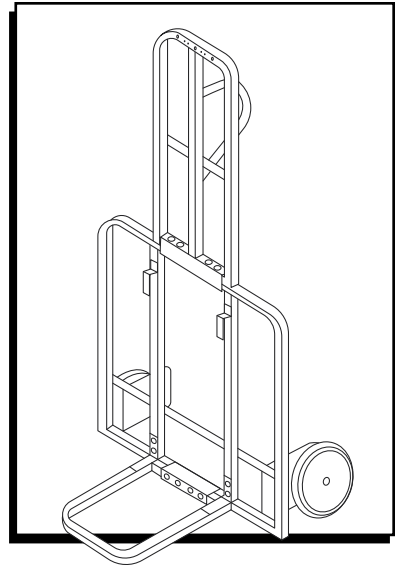

HERRAMIENTAS NECESARIAS



Llave de 13 mm

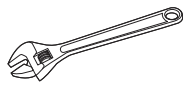

Llave Inglesa

PARTES

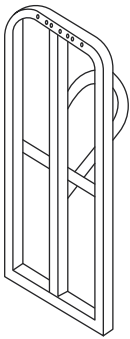

1 Sección Superior

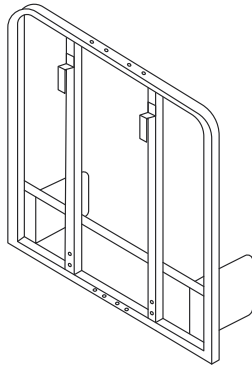

1 Sección Inferior

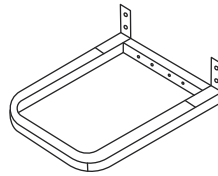

1 Sección de Base

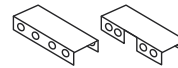

2 Soportes en C



2 Pasadores de
Chaveta

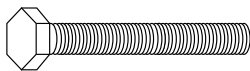

8 Pernos Hexagonales de
5/16 x 2 1/2"

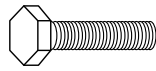

4 Pernos Hexagonales
de 5/16 x 1 1/2"

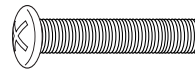

3 Pernos de Cruz de
1/4 x 2"



12 Contratuercas de
13 mm



3 Tuercas de Mariposa

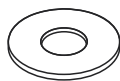

4 Rondanas Planas de 1/2"

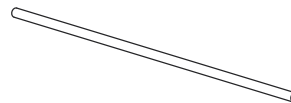

1 Eje



2 Llantas



15 Rondanas Planas de 5/16"

ENSAMBLE



NOTA: Verifique que todas las partes estén incluidas.

1. Fije la base a la sección inferior utilizando uno de los soportes en C y cuatro pernos hexagonales de 5/16 x 2 1/2". Asegure los pernos con cuatro rondanas planas de 5/16" y contratuercas de 13 mm. (Vea Diagrama 1)



NOTA: Las cabezas de los pernos deben apuntar hacia el frente de la unidad.
No apriete las contratuercas en este punto.

2. Asegure la sección base a la sección inferior usando cuatro pernos hexagonales de 5/16 x 1 1/2", rondanas planas de 5/16" y contratuercas de seguridad a los soportes en L de la sección base. (Vea Diagrama 1)

3. Fije la sección superior a la sección inferior utilizando el soporte en C restante y cuatro pernos hexagonales de 5/16 x 2 1/2". Asegure los pernos con cuatro rondanas planas de 5/16" y contratuercas de 13mm. (Vea Diagrama 2)
4. Apriete todas las contratuercas.

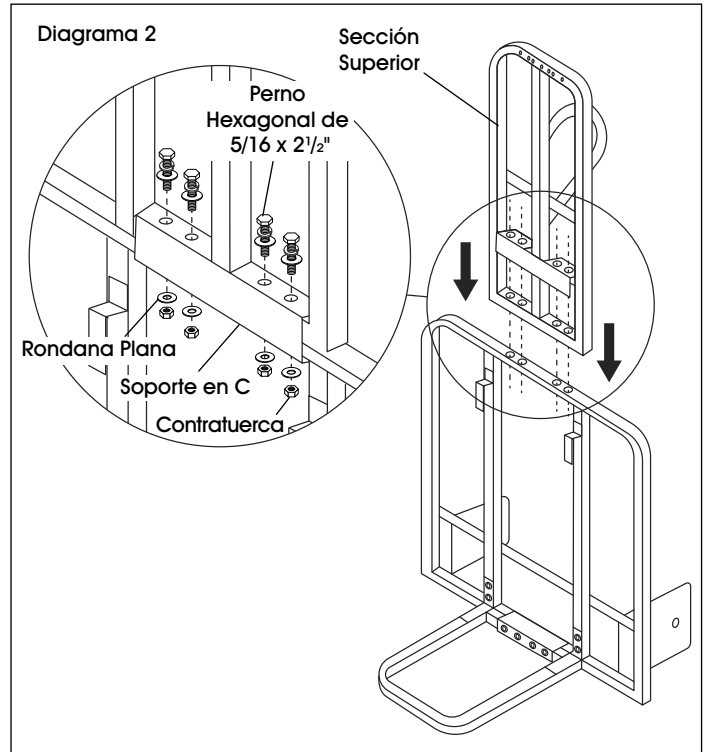
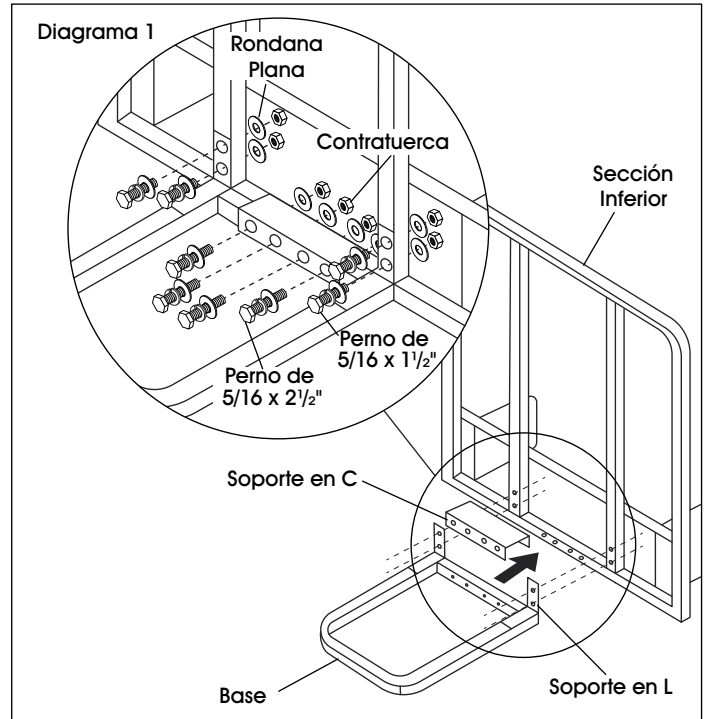

CONTINUACIÓN DEL ENSAMBLE

5. Deslice el eje a través de ambos brazos de soporte del eje.
6. Instale una rondana plana de 1/2", llanta y otra rondana plana de 1/2" en un extremo del eje. Inserte el pasador de chaveta a través del orificio del eje para asegurar la llanta. Repita la operación con el lado opuesto. (Vea Diagrama 3)

 **NOTA:** Los centros de las llantas deben apuntar hacia el soporte del eje.

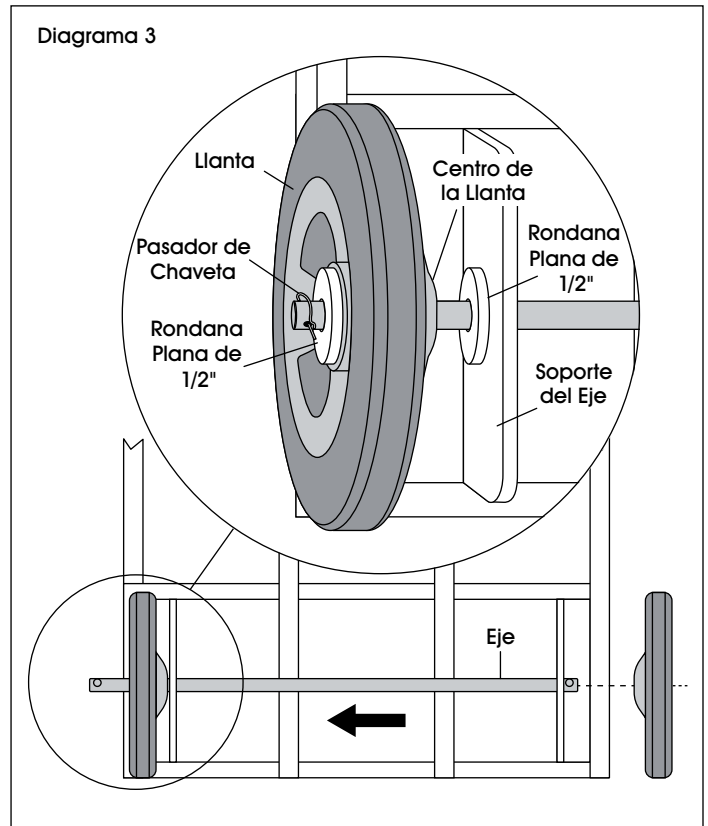

ENSAMBLE DEL SOPORTE DEL LAVAOJOS

 **NOTA:** El soporte del lavaojos se incluye con la estación lavaojos.

 **NOTA:** Es posible que el soporte no concuerde con el Diagrama 4 y solo requiera dos pernos.

1. Instale el soporte del lavaojos al carrito portátil utilizando pernos de cruz de 1/4 x 2". Asegure los pernos con rondanas planas de 5/16" y tuercas de mariposa. (Vea Diagrama 4)

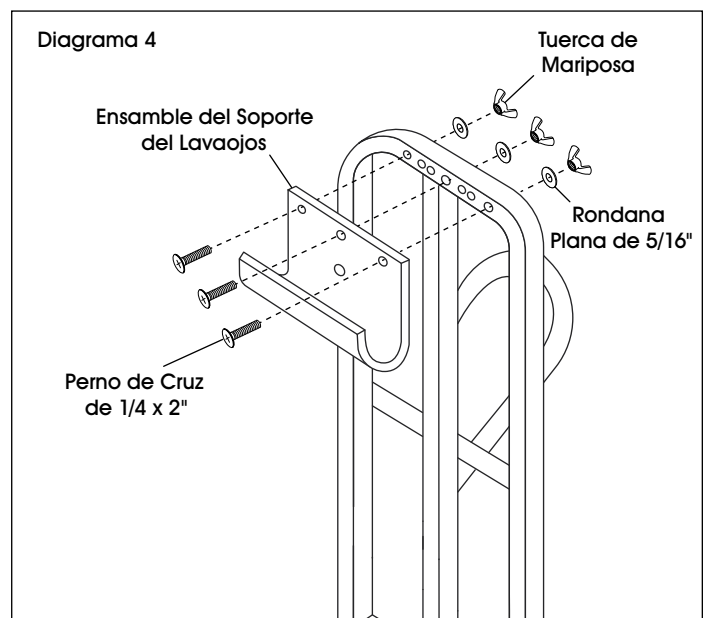

ULINE

800-295-5510
uline.mx

ULINE H-9839

CHARIOT POUR DOUCHE OCULAIRE

1 800 295-5510
uline.ca

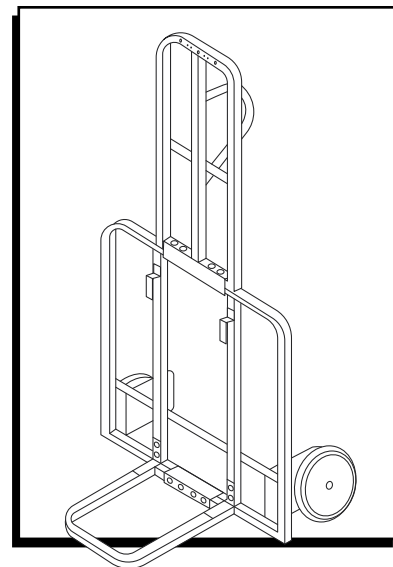

OUTILS REQUIS



Clé de 13 mm



Clé à molette

PIÈCES

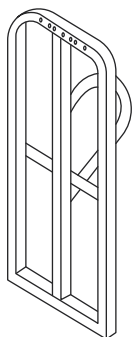

Section supérieure x 1

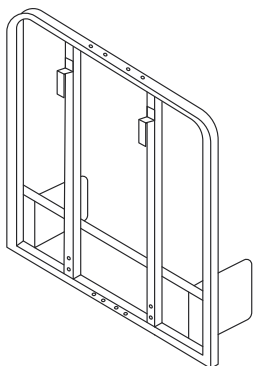

Section inférieure x 1

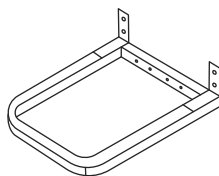

Section de base x 1

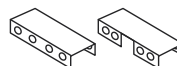

Support en C x 2



Goupille fendue x 2

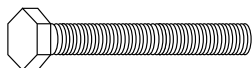

Boulon hexagonal de
5/16 x 2 1/2 po x 8

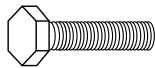

Boulon hexagonal de
5/16 x 1 1/2 po x 4

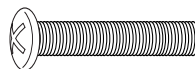

Boulon cruciforme de
1/4 x 2 po x 3



Écrou de blocage de
13 mm x 12



Écrou à oreilles x 3



Rondelle plate de
1/2 po x 4

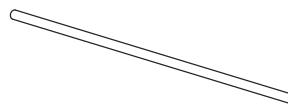

Essieu x 1



Roue x 2



Rondelle plate de
5/16 po x 15

MONTAGE



REMARQUE : Vérifiez que toutes les pièces sont incluses.

1. Reliez la section de base à la section inférieure avec un support en C et quatre boulons hexagonaux de 5/16 x 2 1/2 po. Fixez les boulons avec quatre rondelles plates de 5/16 po et quatre écrous de blocage de 13 mm. (Voir Figure 1)



REMARQUE : Les têtes des boulons doivent être orientées vers l'avant du chariot.
Ne serrez pas les écrous à cette étape.

2. Fixez la section de base à la section inférieure avec quatre boulons hexagonaux de 5/16 x 1 1/2 po, quatre rondelles plates de 5/16 po et quatre écrous de blocage de 13 mm au niveau des supports en L situés sur la section de base. (Voir Figure 1)

3. Reliez la section supérieure à la section inférieure avec le second support en C et quatre boulons hexagonaux de 5/16 x 2 1/2 po. Fixez les boulons avec quatre rondelles plates de 5/16 po et quatre écrous de blocage de 13 mm. (Voir Figure 2)
4. Serrez tous les écrous.

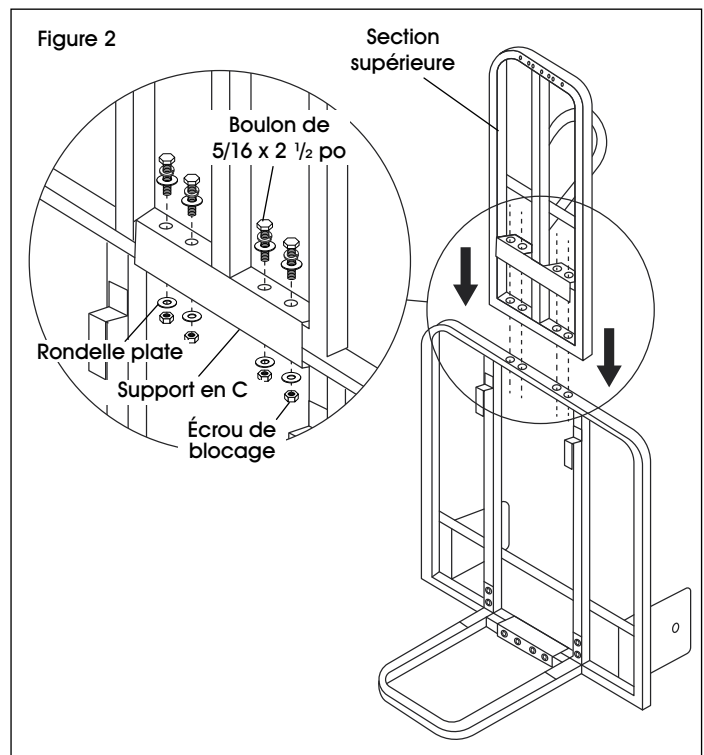
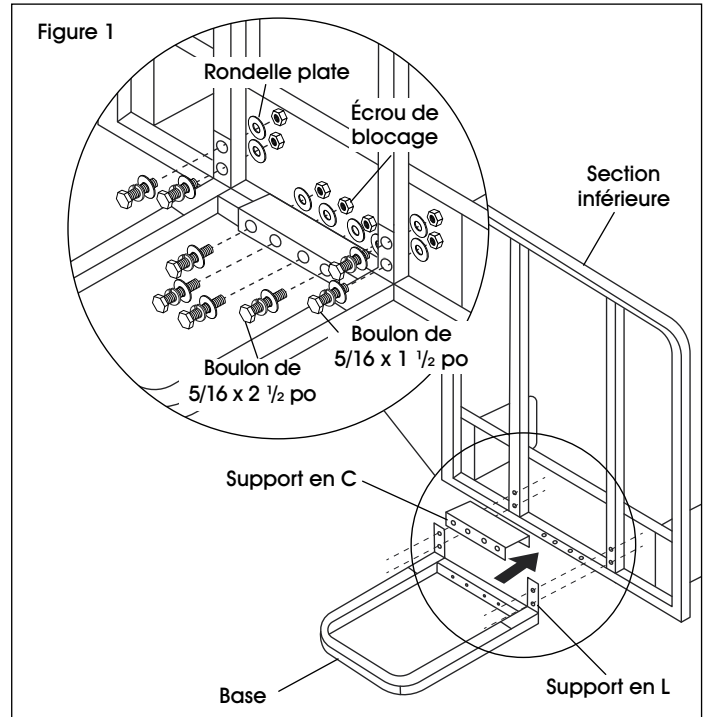

MONTAGE SUITE

- Faites glisser l'essieu à travers les deux supports d'appui pour essieu.
- Placez une rondelle plate de 1/2 po, une roue et une autre rondelle plate de 1/2 po à l'extrémité de l'essieu. Insérez la goupille fendue à travers le trou de l'essieu pour fixer la roue. Répétez la procédure sur le côté opposé. (Voir Figure 3)

 **REMARQUE :** Les moyeux des roues doivent faire face au support d'appui.

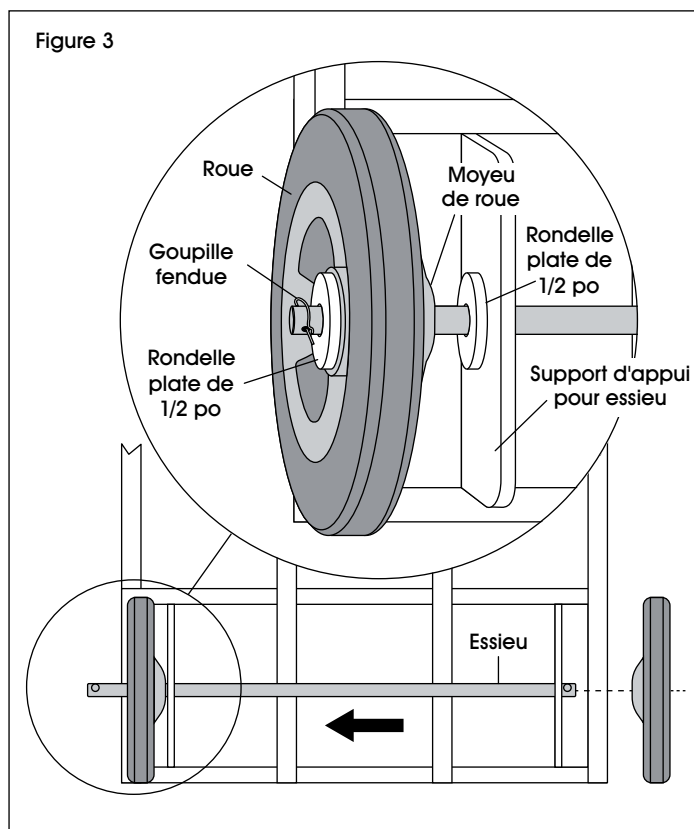

MONTAGE DU SUPPORT D'APPUI POUR DOUCHE OCULAIRE

 **REMARQUE :** Un support d'appui est inclus avec la douche oculaire.

 **REMARQUE :** Il se peut que le support ne corresponde pas à celui illustré à la Figure 4 et qu'il ne nécessite que deux boulons.

- Montez le support d'appui pour douche oculaire sur le chariot avec boulons cruciformes de 1/4 x 2 po. Fixez les boulons avec des rondelles plates de 5/16 po et trois écrous à oreilles. (Voir Figure 4)

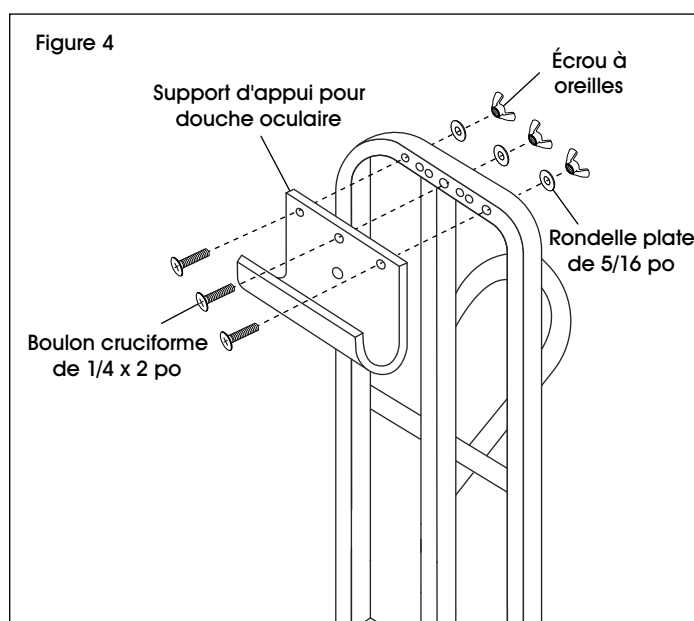

ULINE

1 800 295-5510
uline.ca