

ULINE H-993 MONARCH 1155® TWO LINE LABEL GUN

1-800-295-5510
uline.com

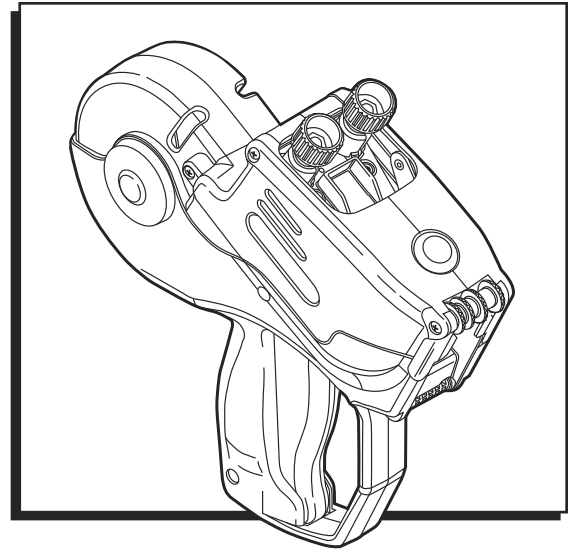

OPERATION

CHANGING THE INK ROLLER

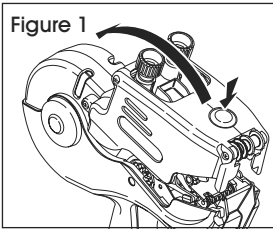

1. Push the release button and swing the cover open until it clicks. (See Figure 1)

 **NOTE:** Do not force the cover past the click position.

2. Push the release bar to release ink roller. (See Figure 2)

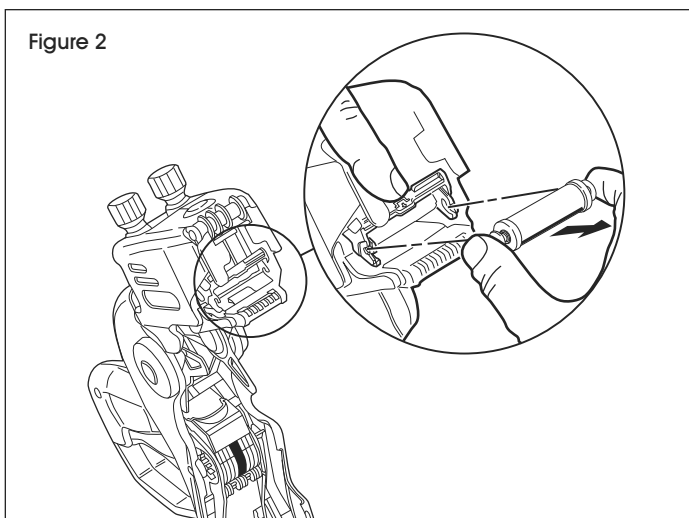

3. Hold the ink roller on each end, remove and discard.
4. Hold the new ink roller on each end and snap into place.

SETTING PRINT CHARACTERS

1. For the first line, use the character key on the side of the gun to find the alpha character conversion.
2. Pull the knob out until the indicators are on the desired band. (See Figure 3)

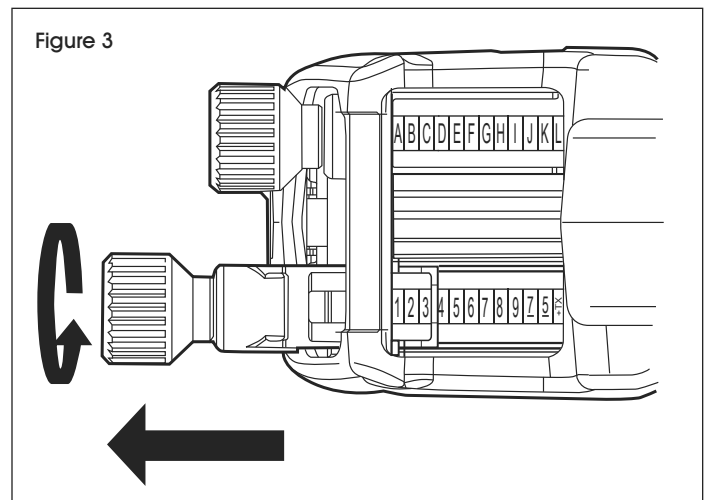

3. Turn the knob until the desired character appears black on a white background between the indicators. To print a blank, select the blank space for that band.
4. Repeat steps 2-3 for each band.
5. Push the knob in when done.

OPERATION CONTINUED

LOADING LABELS

1. Push the release button and swing the cover open until it clicks. (See Figure 4)

 **NOTE:** Do not force the cover past the click position.

2. For loading a new roll of labels, tear off and discard the first 10" of label and liner.
3. Peel the first 12 labels from liner and discard.
4. Place the label roll between the hubs and click into place. (See Figure 4)

 **NOTE:** Do not thread label strip through any rollers.

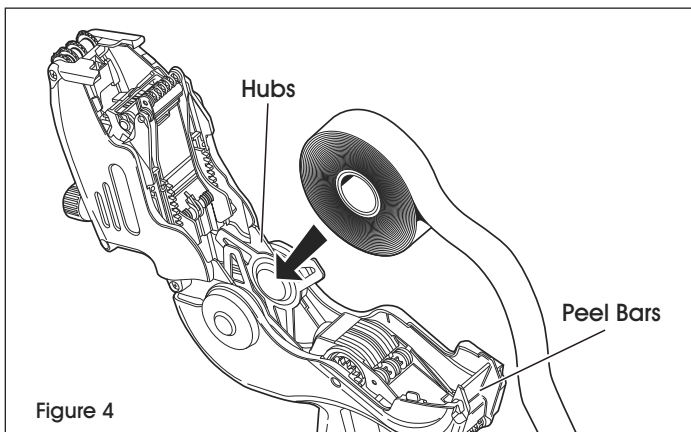

5. Drape the supply across the labeler and center it over the peel bar. The supply should hang out 6-7" past the peel bar.
6. Close the cover.
7. Squeeze and hold the trigger while feeding the label strip under the roller and into the large slot above the arrow until it stops/hits the back. (See Figure 5)

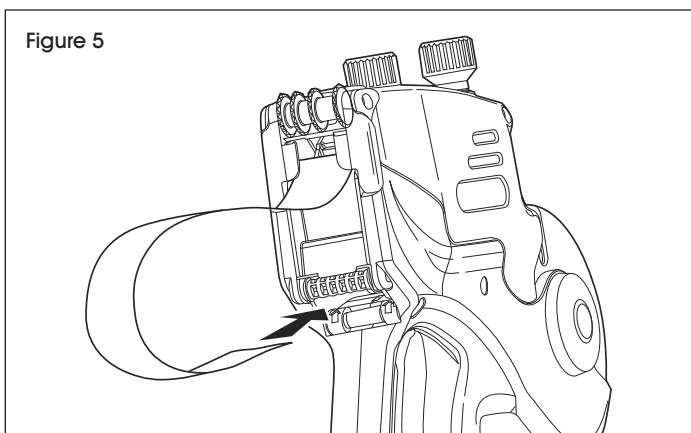

8. Hold the strip in place and squeeze the trigger eight times or until the label strip feeds through the rear exit.
9. Remove any loose labels.

CLEARING LABEL JAMS, CLEANING AND LUBRICATION

1. Open the cover and remove the label roll.
2. Remove any loose labels from the inside of the labeler. (See Figure 6)

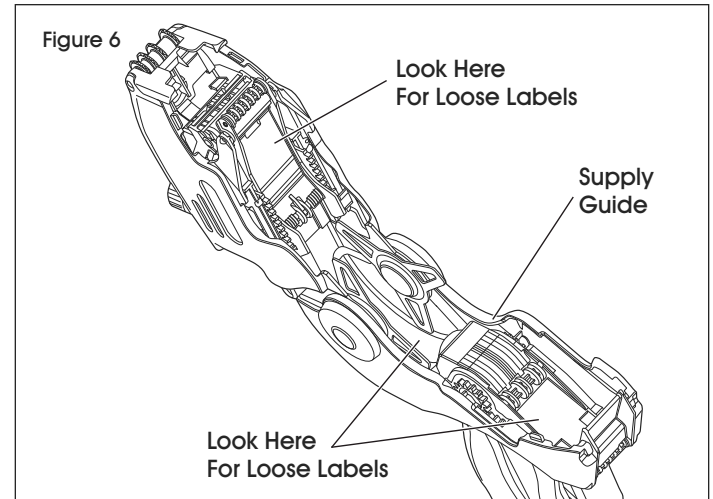

3. Pull up on the supply guide to expose the backing paper path and remove loose labels. (See Figure 7)

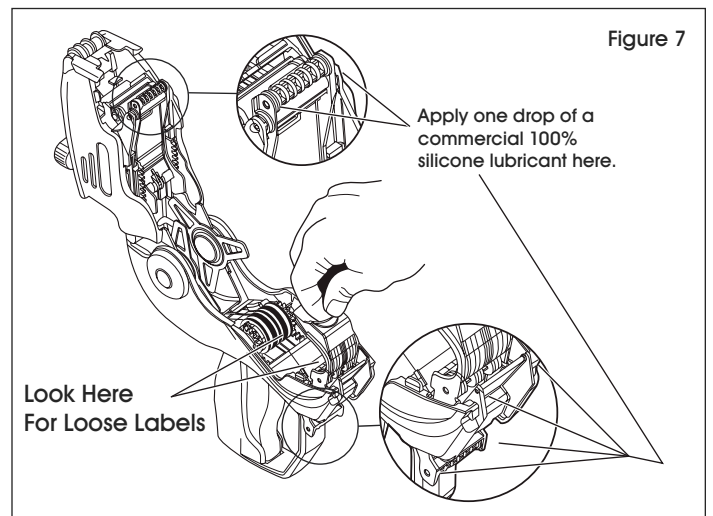

4. Snap the supply guide back into place.
5. Use a commercial adhesive solvent to clean adhesive buildup.
6. Remove the ink roller to expose the print bands and brush them off with a toothbrush.
7. Reload, then close the cover.

CHARACTER KEY



NOTE: 1st Line Wheel: Opposite side of wheel print. (Example: When "A" is in the window, "N" will print, and vice versa.)

NOT INDICATIVE OF FONT SIZE AND STYLE.

Regular Font (5 MM) 1st Line

KNOB POSITION											
1	2	3	4	5	6	7	8	9	10	11	12
A↔N	A↔N	A↔N	A↔N	A↔N	A↔N	A↔N	A↔N	A↔N	A↔N	A↔N	A↔N
B↔O	B↔O	B↔O	B↔O	B↔O	B↔O	B↔O	B↔O	B↔O	B↔O	B↔O	B↔O
C↔P	C↔P	C↔P	C↔P	C↔P	C↔P	C↔P	C↔P	C↔P	C↔P	C↔P	C↔P
D↔Q	D↔Q	D↔Q	D↔Q	D↔Q	D↔Q	D↔Q	D↔Q	D↔Q	D↔Q	D↔Q	D↔Q
E↔R	E↔R	E↔R	E↔R	E↔R	E↔R	E↔R	E↔R	E↔R	E↔R	E↔R	E↔R
F↔S	F↔S	F↔S	F↔S	F↔S	F↔S	F↔S	F↔S	F↔S	F↔S	F↔S	F↔S
G↔T	G↔T	G↔T	G↔T	G↔T	G↔T	G↔T	G↔T	G↔T	G↔T	G↔T	G↔T
H↔U	H↔U	H↔U	H↔U	H↔U	H↔U	H↔U	H↔U	H↔U	H↔U	H↔U	H↔U
I↔V	I↔V	I↔V	I↔V	I↔V	I↔V	I↔V	I↔V	I↔V	I↔V	I↔V	I↔V
J↔W	J↔W	J↔W	J↔W	J↔W	J↔W	J↔W	J↔W	J↔W	J↔W	J↔W	J↔W
K↔X	K↔X	K↔X	K↔X	K↔X	K↔X	K↔X	K↔X	K↔X	K↔X	K↔X	K↔X
L↔Y	L↔Y	L↔Y	L↔Y	L↔Y	L↔Y	L↔Y	L↔Y	L↔Y	L↔Y	L↔Y	L↔Y
M↔Z	M↔Z	M↔Z	M↔Z	M↔Z	M↔Z	M↔Z	M↔Z	M↔Z	M↔Z	M↔Z	M↔Z
READ/PRINT ↔ PRINT/READ											

Regular Font (5 MM) 2nd Line

KNOB POSITION											
1	2	3	4	5	6	7	8	9	10	11	12
1	1	1	1	1	1	.	.	.	<u>1</u>	<u>1</u>	LB
2	2	2	2	2	2	1	1	1	<u>2</u>	<u>2</u>	EACH
3	3	3	3	3	3	2	2	2	<u>3</u>	<u>3</u>	FOOT
4	4	4	4	4	4	3	3	3	<u>4</u>	<u>4</u>	YARD
5	5	5	5	5	5	4	4	4	<u>5</u>	<u>5</u>	DOZ
6	6	6	6	6	6	5	5	5	<u>6</u>	<u>6</u>	PAIR
7	7	7	7	7	7	6	6	6	<u>7</u>	<u>7</u>	PKG
8	8	8	8	8	8	7	7	7	<u>8</u>	<u>8</u>	BOX
9	9	9	9	9	9	8	8	8	<u>9</u>	<u>9</u>	CASE
0	0	0	0	0	0	9	9	9	<u>0</u>	<u>0</u>	SET
\$	\$	\$	\$	\$	\$	0	0	0	+TX	+TX	OFF
FOR	FOR	FOR	FOR	FOR	FOR	\$	\$	\$	EACH	EACH	+DEP
/	/	/	/	/	/	¢	¢	¢	¢	¢	+TX

ULINE

1-800-295-5510
uline.com

ULINE H-993

800-295-5510

uline.mx

MONARCH 1155® PISTOLA ETIQUETADORA NUMÉRICA - DOS LÍNEAS

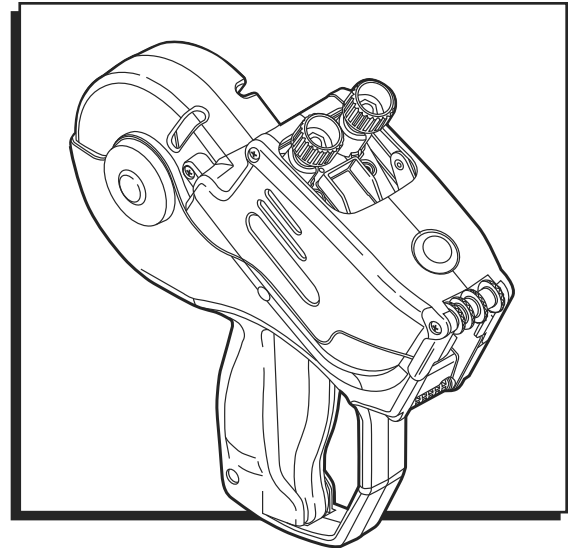

FUNCIONAMIENTO

CAMBIAR EL RODILLO DE TINTA

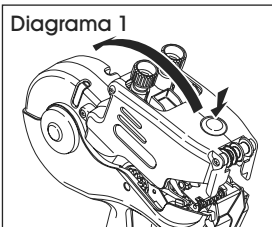

1. Presione el botón de liberación y abra la cubierta hasta que haga clic. (Vea Diagrama 1)

 **NOTA:** No fuerce la cubierta después de pasar la posición del clic.

2. Presione la barra para liberar el rodillo de tinta. (Vea Diagrama 2)

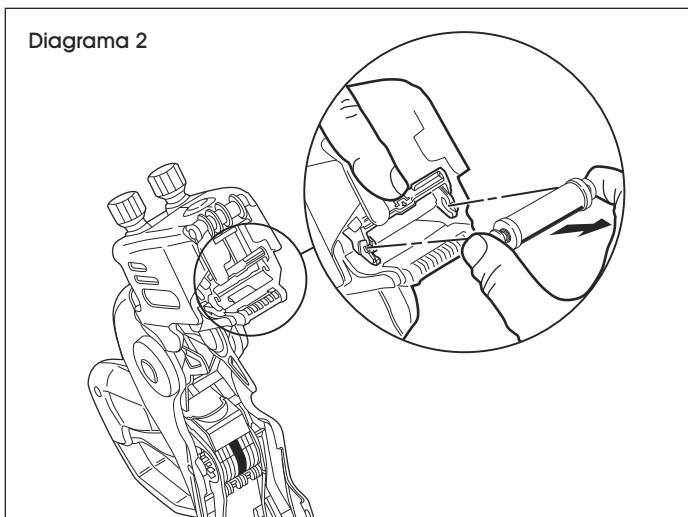

3. Sostenga el rodillo de tinta en cada extremo, retire y deseche.
4. Sostenga el nuevo rodillo de tinta en cada extremo y ajuste hasta que haga clic en su lugar.

CONFIGURAR CARACTERES DE IMPRESIÓN

1. Para la primera línea, utilice la clave de caracteres al lado de la etiquetadora para encontrar la conversión alfabética.
2. Jale la perilla hasta que los indicadores estén sobre la banda deseada. (Vea Diagrama 3)

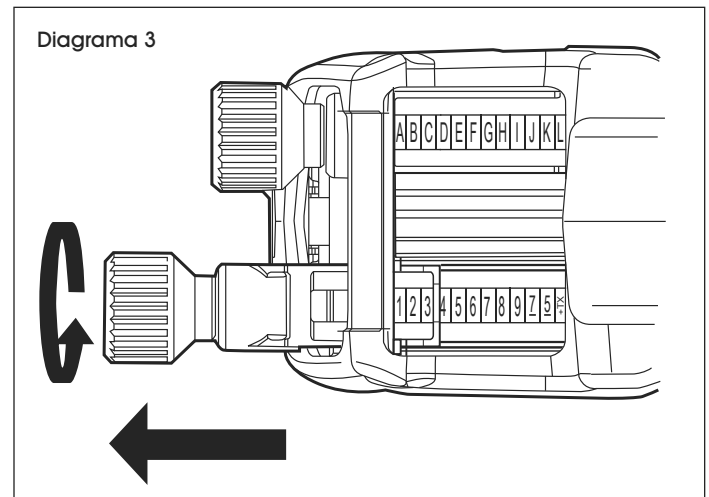

3. Gire la perilla hasta que el caracter deseado aparezca negro sobre fondo blanco entre los indicadores. Para imprimir un espacio blanco, seleccione el espacio blanco en esa banda.
4. Repita los pasos 2-3 para cada banda.
5. Empuje la perilla cuando haya terminado.

CONTINUACIÓN DE FUNCIONAMIENTO

CARGAR ETIQUETAS

1. Presione el botón de liberación y abra la cubierta hasta que haga clic. (Vea Diagrama 4)

 **NOTA:** No fuerce la cubierta después de pasar la posición del clic.

2. Para cargar un nuevo rollo de etiquetas, despegue y deseche los primeros 25 cm (10") de etiquetas y respaldo.
3. Despegue las primeras 12 etiquetas del respaldo y deséchelas.
4. Coloque el rollo de etiquetas entre los núcleos y presione hasta hacer clic. (Vea Diagrama 4)

 **NOTA:** No haga pasar la tira de etiquetas a través de ninguno de los rodillos.

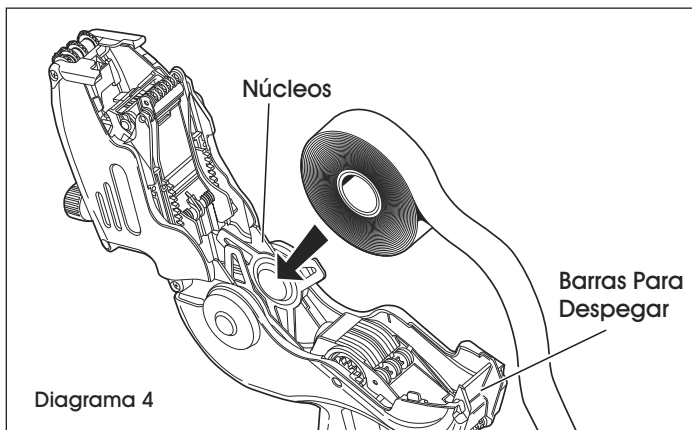

5. Deje colgando un tramo del suministro a través de la etiquetadora y céntralo sobre la barra para despegar. El tramo de suministro deberá colgar 15-18 cm (6-7") pasando la barra para despegar.
6. Cierre la cubierta.
7. Apriete y sostenga el gatillo mientras alimenta la tira de etiquetas debajo del rodillo y dentro de la ranura grande arriba de la flecha hasta que pare/pegue en la parte posterior. (Vea Diagrama 5)

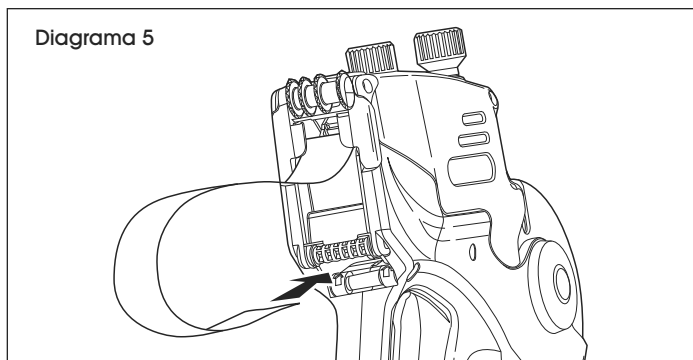

8. Sostenga la tira en su lugar y apriete el gatillo ocho veces o hasta que la tira de etiquetas salga por la parte posterior.
9. Retire cualquier etiqueta suelta.

DESPEJAR ATASCOS DE ETIQUETAS, LIMPIEZA Y LUBRICACIÓN

1. Abra la cubierta y retire el rollo de etiquetas.
2. Retire cualquier etiqueta suelta del interior de la etiquetadora. (Vea Diagrama 6)

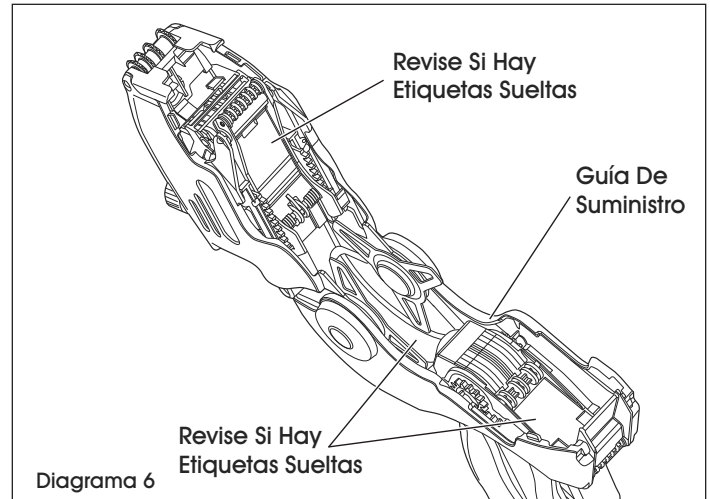

3. Jale hacia arriba la guía de suministro para exponer el trayecto del respaldo de papel y retire las etiquetas sueltas. (Vea Diagrama 7)

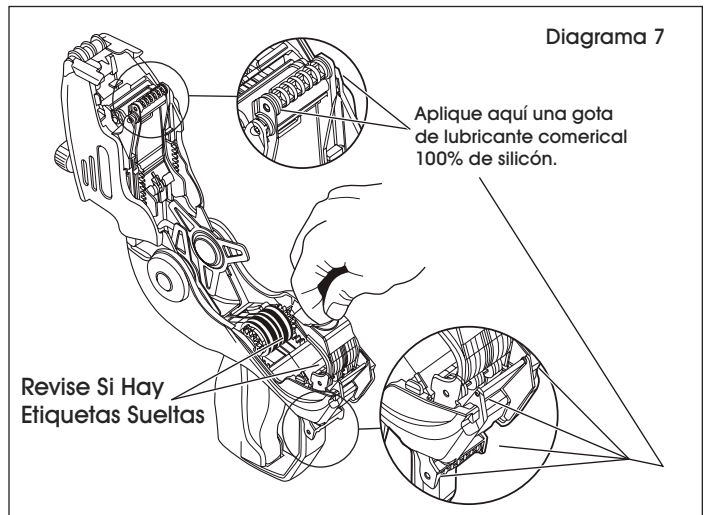

4. Coloque hasta que haga clic la guía de suministro de regreso a su lugar.
5. Utilice un solvente de adhesivo comercial para limpiar la acumulación de adhesivo.
6. Retire el rodillo de tinta para exponer las bandas de impresión y cepíllelas con un cepillo dental.
7. Recargue, luego cierre la cubierta.

CLAVE DE CARACTERES



NOTA: Rueda de 1a. Línea: Imprime el lado opuesto de la rueda. (Ejemplo: Cuando "A" está en la ventana, "N" imprimirá, y viceversa.)

NO INDICA EL TAMAÑO Y ESTILO DE LETRA.

Letra Regular (5 MM) 1a. Línea

POSICIÓN DE LA PERILLA											
1	2	3	4	5	6	7	8	9	10	11	12
A↔N	A↔N	A↔N	A↔N	A↔N	A↔N	A↔N	A↔N	A↔N	A↔N	A↔N	A↔N
B↔O	B↔O	B↔O	B↔O	B↔O	B↔O	B↔O	B↔O	B↔O	B↔O	B↔O	B↔O
C↔P	C↔P	C↔P	C↔P	C↔P	C↔P	C↔P	C↔P	C↔P	C↔P	C↔P	C↔P
D↔Q	D↔Q	D↔Q	D↔Q	D↔Q	D↔Q	D↔Q	D↔Q	D↔Q	D↔Q	D↔Q	D↔Q
E↔R	E↔R	E↔R	E↔R	E↔R	E↔R	E↔R	E↔R	E↔R	E↔R	E↔R	E↔R
F↔S	F↔S	F↔S	F↔S	F↔S	F↔S	F↔S	F↔S	F↔S	F↔S	F↔S	F↔S
G↔T	G↔T	G↔T	G↔T	G↔T	G↔T	G↔T	G↔T	G↔T	G↔T	G↔T	G↔T
H↔U	H↔U	H↔U	H↔U	H↔U	H↔U	H↔U	H↔U	H↔U	H↔U	H↔U	H↔U
I↔V	I↔V	I↔V	I↔V	I↔V	I↔V	I↔V	I↔V	I↔V	I↔V	I↔V	I↔V
J↔W	J↔W	J↔W	J↔W	J↔W	J↔W	J↔W	J↔W	J↔W	J↔W	J↔W	J↔W
K↔X	K↔X	K↔X	K↔X	K↔X	K↔X	K↔X	K↔X	K↔X	K↔X	K↔X	K↔X
L↔Y	L↔Y	L↔Y	L↔Y	L↔Y	L↔Y	L↔Y	L↔Y	L↔Y	L↔Y	L↔Y	L↔Y
M↔Z	M↔Z	M↔Z	M↔Z	M↔Z	M↔Z	M↔Z	M↔Z	M↔Z	M↔Z	M↔Z	M↔Z
READ/PRINT ↔ PRINT/READ											

Letra Regular (5 MM) 2a. Línea

POSICIÓN DE LA PERILLA											
1	2	3	4	5	6	7	8	9	10	11	12
1	1	1	1	1	1	.	.	.	<u>1</u>	<u>1</u>	LB
2	2	2	2	2	2	1	1	1	<u>2</u>	<u>2</u>	EACH
3	3	3	3	3	3	2	2	2	<u>3</u>	<u>3</u>	FOOT
4	4	4	4	4	4	3	3	3	<u>4</u>	<u>4</u>	YARD
5	5	5	5	5	5	4	4	4	<u>5</u>	<u>5</u>	DOZ
6	6	6	6	6	6	5	5	5	<u>6</u>	<u>6</u>	PAIR
7	7	7	7	7	7	6	6	6	<u>7</u>	<u>7</u>	PKG
8	8	8	8	8	8	7	7	7	<u>8</u>	<u>8</u>	BOX
9	9	9	9	9	9	8	8	8	<u>9</u>	<u>9</u>	CASE
0	0	0	0	0	0	9	9	9	<u>0</u>	<u>0</u>	SET
\$	\$	\$	\$	\$	\$	0	0	0	+TX	+TX	OFF
FOR	FOR	FOR	FOR	FOR	FOR	\$	\$	\$	EACH	EACH	+DEP
/	/	/	/	/	/	¢	¢	¢	¢	¢	+TX

ULINE

800-295-5510
uline.mx

ULINE H-993

MONARCH 1155^{MD} PISTOLET-ÉTIQUETEUSE À DEUX LIGNES

1 800 295-5510
uline.ca

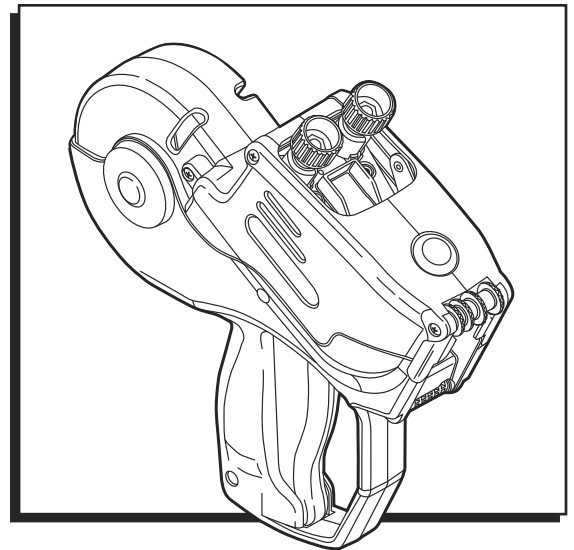

FONCTIONNEMENT

CHANGEMENT DU ROULEAU ENCREUR

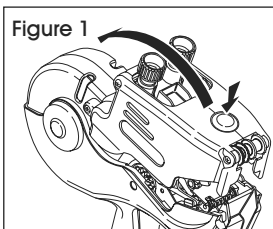

1. Tirez sur le bouton de déverrouillage et ouvrez le couvercle jusqu'à ce qu'il s'enclenche. (Voir Figure 1)

 **REMARQUE :** Ne forcez pas le couvercle au-delà de la position du déclic.

2. Poussez le levier de déclenchement pour libérer le rouleau encreur. (Voir Figure 2)

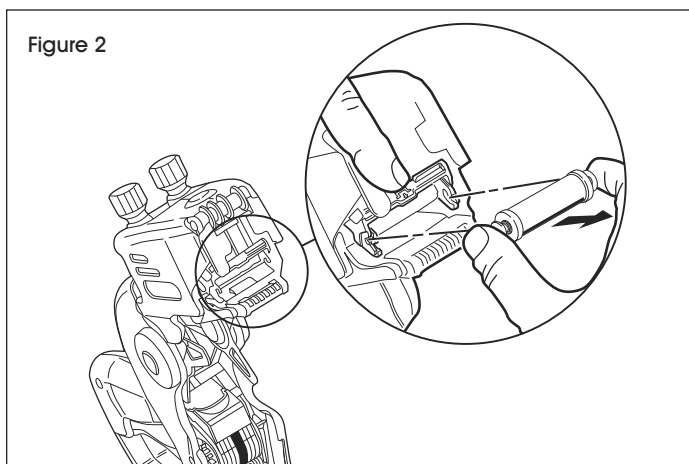

3. Tenez le rouleau encreur par chaque extrémité, retirez-le puis jetez-le.
4. Tenez le nouveau rouleau encreur par chaque extrémité et enclenchez-le en position.

RÉGLAGE DES CARACTÈRES IMPRIMÉS

1. Pour la première ligne, utilisez la touche de caractère sur le côté de l'étiqueteuse pour trouver la conversion de caractères alpha.
2. Tirez sur le bouton jusqu'à ce que les indicateurs soient sur la bande désirée. (Voir Figure 3)

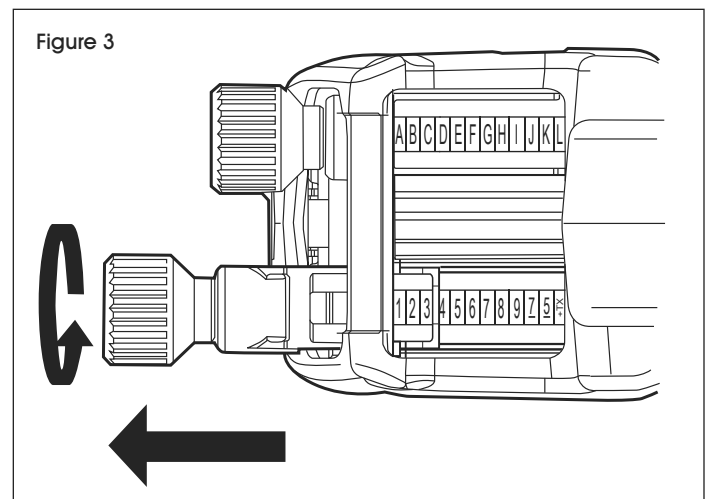

3. Tournez le bouton jusqu'à ce que le caractère souhaité apparaisse en noir sur fond blanc entre les indicateurs. Pour imprimer un blanc, sélectionnez l'espace en blanc pour cette bande.
4. Répétez les étapes 2 et 3 pour chaque bande.
5. Appuyez sur le bouton lorsque vous avez terminé.

CHARGEMENT DES ÉTIQUETTES

1. Tirez sur le bouton de déverrouillage et ouvrez le couvercle jusqu'à ce qu'il s'enclenche. (Voir Figure 4)

 **REMARQUE :** Ne forcez pas le couvercle au-delà de la position du déclic.

2. Pour charger un nouveau rouleau d'étiquettes, arrachez et jetez les 25 cm (10 po) initiaux d'étiquettes et de doublure.
3. Décollez les 12 premières étiquettes de la doublure et jetez-les.
4. Placez le rouleau d'étiquettes entre les moyeux et enclenchez-le en position. (Voir Figure 4)

 **REMARQUE :** N'enfilez pas de bande d'étiquettes au travers des rouleaux.

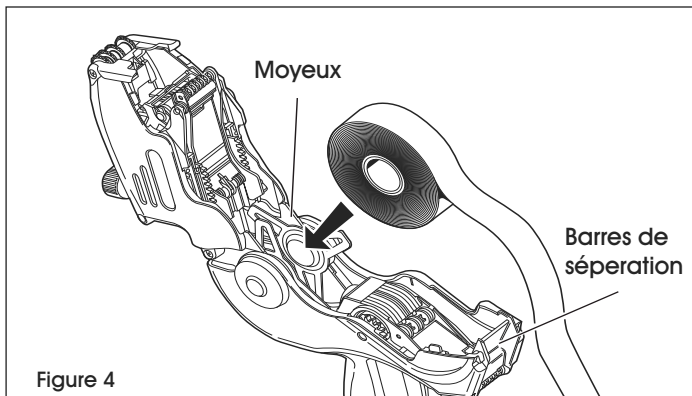

5. Déposez la bande sur l'étiqueteuse et centrez-la sur la barre de séparation. La bande devrait dépasser de 15 à 18 cm (6 à 7 po) au-delà de la barre de séparation.
6. Fermez le couvercle.
7. Pressez et maintenez la détente enfoncée tout en alimentant la bande d'étiquettes sous le rouleau et jusque dans la grande fente au-dessus de la flèche, jusqu'à ce qu'elle s'arrête ou atteigne l'arrière. (Voir Figure 5)

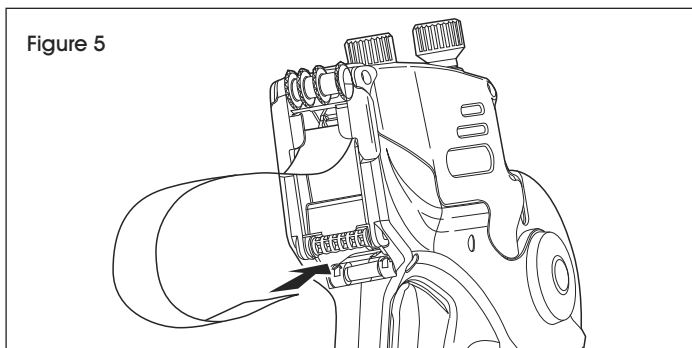

8. Maintenez la bande en place et appuyez sur la détente huit fois ou jusqu'à ce que la bande d'étiquettes émerge de la sortie arrière.

9. Enlevez toute étiquette lâche.

DÉPANNAGE DES BOURRAGES, NETTOYAGE ET LUBRIFICATION

1. Ouvrez le couvercle et retirez le rouleau d'étiquettes.
2. Enlevez toute étiquette lâche à l'intérieur de l'étiqueteuse. (Voir Figure 6)

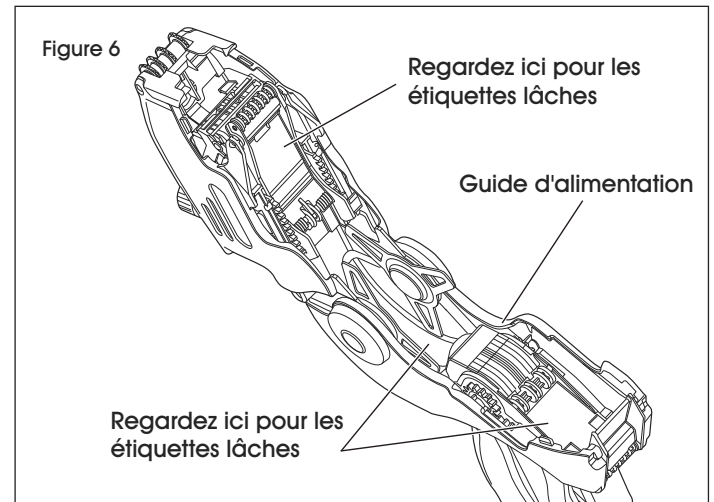

3. Tirez sur le guide d'alimentation pour révéler le chemin du papier dorsal et pour retirer les étiquettes lâches. (Voir Figure 7)

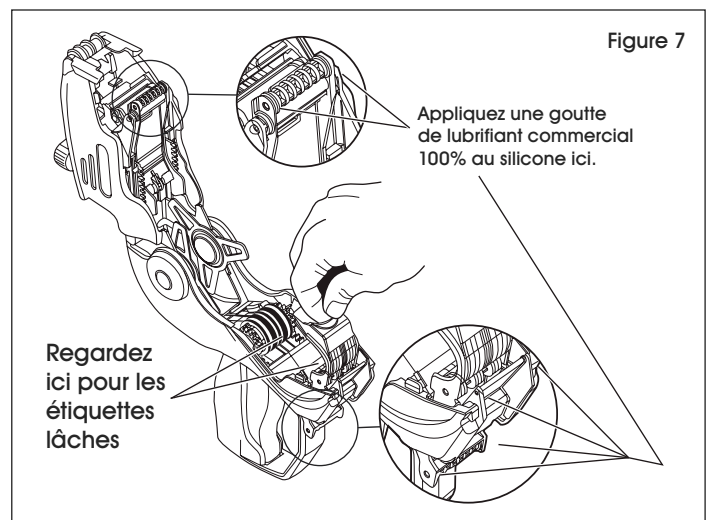

4. Encliquez le guide d'alimentation dans sa position originale.
5. Utilisez un solvant commercial pour adhésif afin de nettoyer l'accumulation d'adhésif.
6. Retirez le rouleau encreur pour exposer les bandes d'impression, et nettoyez-les avec une brosse à dents.
7. Rechargez, puis fermez le couvercle.

TOUCHE DE CARACTÈRE



REMARQUE : Roue de 1 re Ligne: Le côté opposé de la roue est imprimé. (Lorsque "A" apparaît dans fenêtre, "N" sera imprimé et vice-versa.)

PAS REPRESENTATIF DE LA TAILLE OU DU STYLE DE POLICE.

Police régulière (3 MM) Ligne 1

KNOB POSITION											
1	2	3	4	5	6	7	8	9	10	11	12
A↔N	A↔N	A↔N	A↔N	A↔N	A↔N	A↔N	A↔N	A↔N	A↔N	A↔N	A↔N
B↔O	B↔O	B↔O	B↔O	B↔O	B↔O	B↔O	B↔O	B↔O	B↔O	B↔O	B↔O
C↔P	C↔P	C↔P	C↔P	C↔P	C↔P	C↔P	C↔P	C↔P	C↔P	C↔P	C↔P
D↔Q	D↔Q	D↔Q	D↔Q	D↔Q	D↔Q	D↔Q	D↔Q	D↔Q	D↔Q	D↔Q	D↔Q
E↔R	E↔R	E↔R	E↔R	E↔R	E↔R	E↔R	E↔R	E↔R	E↔R	E↔R	E↔R
F↔S	F↔S	F↔S	F↔S	F↔S	F↔S	F↔S	F↔S	F↔S	F↔S	F↔S	F↔S
G↔T	G↔T	G↔T	G↔T	G↔T	G↔T	G↔T	G↔T	G↔T	G↔T	G↔T	G↔T
H↔U	H↔U	H↔U	H↔U	H↔U	H↔U	H↔U	H↔U	H↔U	H↔U	H↔U	H↔U
I↔V	I↔V	I↔V	I↔V	I↔V	I↔V	I↔V	I↔V	I↔V	I↔V	I↔V	I↔V
J↔W	J↔W	J↔W	J↔W	J↔W	J↔W	J↔W	J↔W	J↔W	J↔W	J↔W	J↔W
K↔X	K↔X	K↔X	K↔X	K↔X	K↔X	K↔X	K↔X	K↔X	K↔X	K↔X	K↔X
L↔Y	L↔Y	L↔Y	L↔Y	L↔Y	L↔Y	L↔Y	L↔Y	L↔Y	L↔Y	L↔Y	L↔Y
M↔Z	M↔Z	M↔Z	M↔Z	M↔Z	M↔Z	M↔Z	M↔Z	M↔Z	M↔Z	M↔Z	M↔Z
LIRE/IMPRIMER ↔ IMPRIMER/LIRE											

Police régulière (3 MM) Ligne 2

KNOB POSITION											
1	2	3	4	5	6	7	8	9	10	11	12
1	1	1	1	1	1	.	.	.	<u>1</u>	<u>1</u>	LB
2	2	2	2	2	2	1	1	1	<u>2</u>	<u>2</u>	EACH
3	3	3	3	3	3	2	2	2	<u>3</u>	<u>3</u>	FOOT
4	4	4	4	4	4	3	3	3	<u>4</u>	<u>4</u>	YARD
5	5	5	5	5	5	4	4	4	<u>5</u>	<u>5</u>	DOZ
6	6	6	6	6	6	5	5	5	<u>6</u>	<u>6</u>	PAIR
7	7	7	7	7	7	6	6	6	<u>7</u>	<u>7</u>	PKG
8	8	8	8	8	8	7	7	7	<u>8</u>	<u>8</u>	BOX
9	9	9	9	9	9	8	8	8	<u>9</u>	<u>9</u>	CASE
0	0	0	0	0	0	9	9	9	<u>0</u>	<u>0</u>	SET
\$	\$	\$	\$	\$	\$	0	0	0	+TX	+TX	OFF
FOR	FOR	FOR	FOR	FOR	FOR	\$	\$	\$	EACH	EACH	+DEP
/	/	/	/	/	/	¢	¢	¢	¢	¢	+TX

ULINE

1 800 295-5510
uline.ca