

ULINE

SHELF EXTENSION FOR 30" AND 36" WIDE PACKING TABLES

1-800-295-5510
uline.com

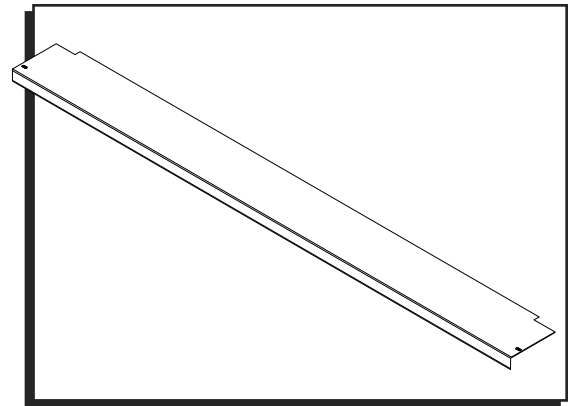

TOOLS NEEDED

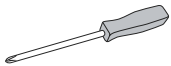

Phillips Screwdriver



7/16" Wrench

PARTS

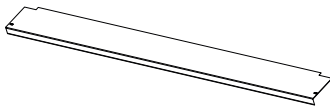

Shelf Extension x 1
(2 Pieces for 96")



1/4"-20 x 5/8" Bolt x 2
(x 4 for 96")



1/4"-20 Nut x 2
(x 4 for 96")

ASSEMBLY



NOTE: Shelf extension has a lip on one side that fits together with existing shelf.

1. Set shelf extension in front of existing shelf, then rest shelf extension on leg braces.
2. Use bolts with nuts to secure. Hold bolt with Phillips screwdriver and tighten nut with 7/16" wrench. (See Figure 1)



NOTE: 96" shelf comes in two pieces.

Figure 1

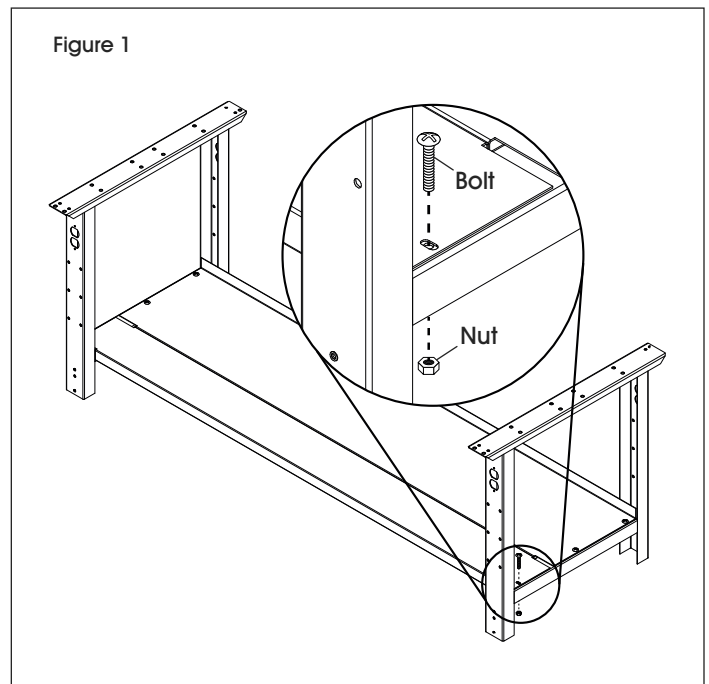

ULINE

EXTENSIÓN DE REPISA PARA MESAS DE TRABAJO DE 30" Y 36" DE GROSOR

800-295-5510
uline.mx

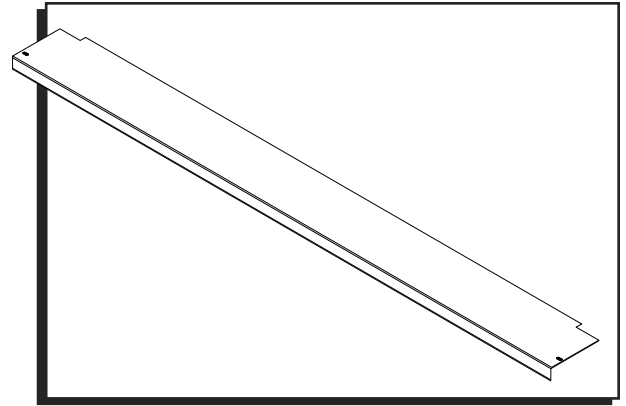

HERRAMIENTAS NECESARIAS

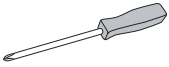

Desarmador de Cruz



Llave de 7/16"

PARTES

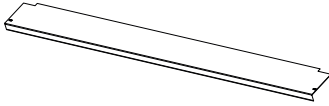

1 Extensión para Repisa
(2 Piezas para 96")



2 Pernos de 1/4"-20 x 5/8"
(4 para 96")



2 Tuercas de 1/4"-20
(4 para 96")

ENSAMBLE



NOTA: La extensión para repisa cuenta con un reborde en un lado que se ajusta a la repisa existente.

1. Coloque la extensión para repisa frente a la repisa existente, luego apoye la extensión sobre los soportes de la pata.
2. Use pernos con tuercas para fijarla. Sostenga el perno con el desarmador de cruz y apriete la tuerca con la llave de 7/16". (Vea Diagrama 1)

Diagrama 1

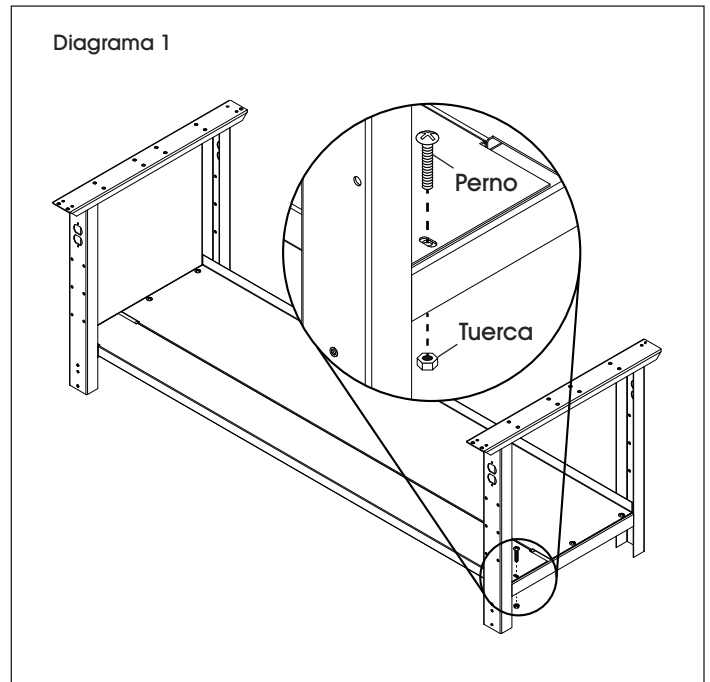

ULINE

1-800-295-5510
uline.ca

RALLONGE DE TABLETTE POUR TABLES D'EMBALLAGE DE 30 PO ET 36 PO DE LARGEUR

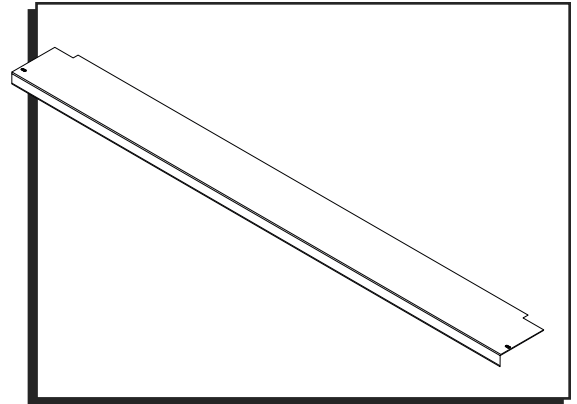

OUTILS REQUIS

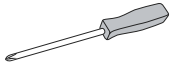

Tournevis cruciforme



Clé de 7/16 po

PIÈCES

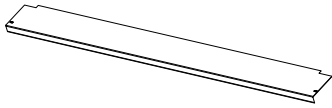

Rallonge de tablette x 1
(2 pièces pour 96 po)



Boulon de 1/4 po-20 x 5/8 po x 2
(x 4 pour 96 po)



Écrou de 1/4 po-20 x 2
(x 4 pour 96 po)

MONTAGE



REMARQUE : La rallonge de tablette a un rebord d'un côté qui s'emboîte avec la tablette existante.

1. Placez la rallonge de tablette devant la tablette existante, puis posez la rallonge de tablette sur les entretoises des pieds.
2. Utilisez les boulons avec les écrous pour la fixer. Maintenez le boulon avec le tournevis cruciforme et serrez l'écrou avec la clé de 7/16 po. (Voir Figure 1)

Figure 1

