

ULINE S-10682
WINE TOTE – 4 BOTTLE

1-800-295-5510
uline.com

Para Español, vea páginas 3-4.
Pour le français, consulter les pages 5-6.

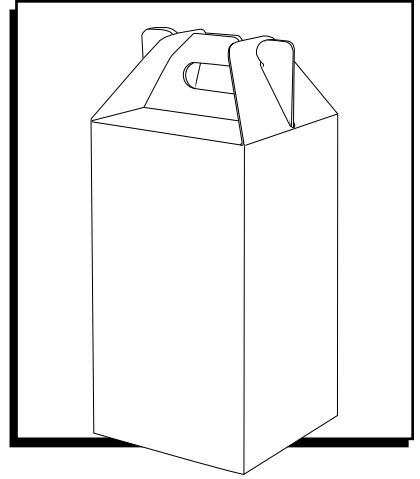

ASSEMBLY

1. Push sides in toward the middle to open tote.
Flip upside down to assemble the bottom.
(See Figure 1)

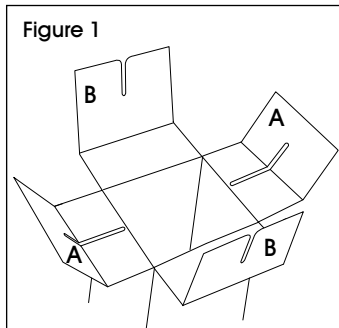

2. Fold flaps (A) at creases and fold inside tote.
(See Figures 2-3)

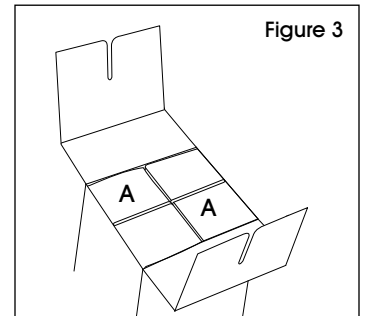
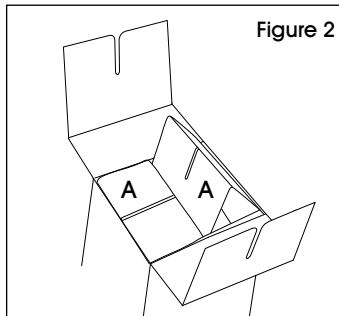

3. Fold flaps (B) at creases and tuck inside middle slot created from step 2. (See Figure 4)
4. Flip the tote over. Tote should have four compartments. (See Figure 5)

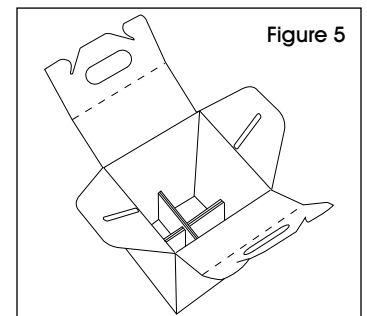
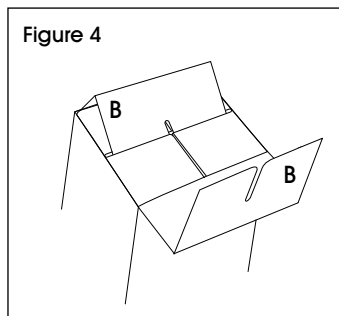

ASSEMBLY CONTINUED

5. To close top, bring two long sides (D) together. Push long sides down to fold at perforations. Slide slotted side tabs (E) over long sides to lock into place. (See Figures 6-7)

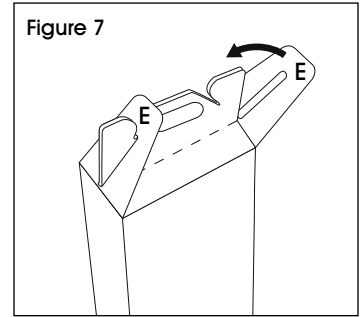
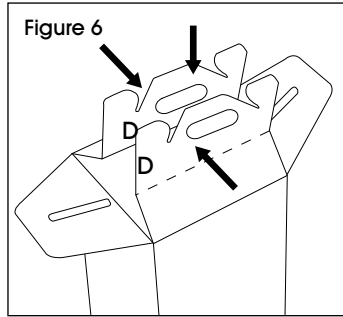

6. Push flap (F) in to create handle hole. (See Figure 8)

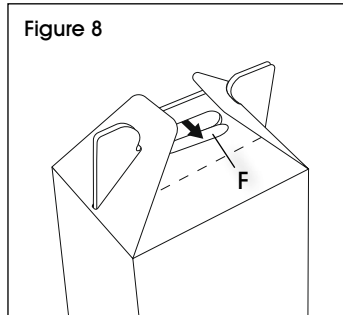

ULINE

1-800-295-5510
uline.com

ULINE S-10682

**CAJA CON ASA
PARA 4 BOTELLAS
DE VINO**

800-295-5510

uline.mx

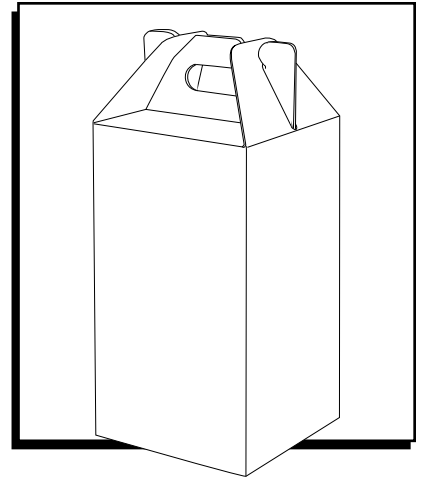

ENSAMBLE

1. Mueva los extremos hacia el centro para abrir la caja. Ponga la caja de cabeza para armar la base. (Vea Diagrama 1)

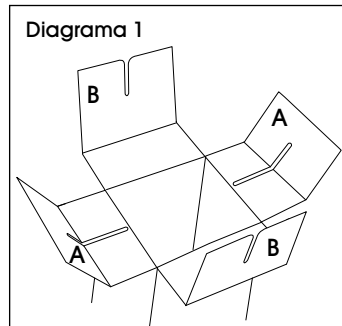

2. Doble las solapas (A) por los pliegues y luego hacia dentro de la caja. Debe haber un espacio entre los dos lados. (Vea Diagrama 2 y 3)

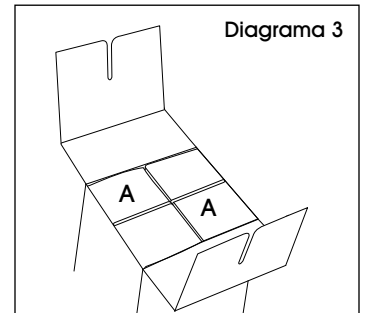
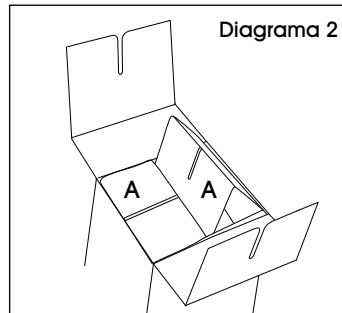

3. Doble las solapas (B) por los pliegues y luego hacia la abertura que se creó en el centro con el paso 2. (Vea Diagrama 4)
4. Enderece la caja. La caja completa debe tener cuatro compartimentos. (Vea Diagrama 5)

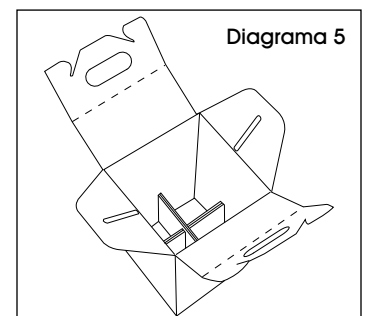
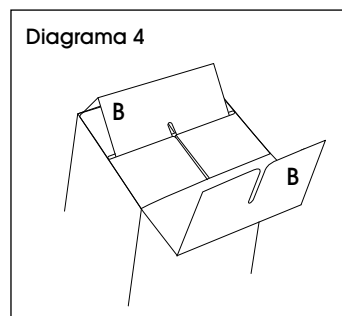

CONTINUACIÓN DE ENSAMBLE

5. Para cerrar la parte de arriba, junte las perforaciones (D), y presione hacia abajo. Deslice las lengüetas perforadas (E) sobre la parte de arriba hasta que se traben en su lugar. (Vea Diagrama 6 y 7)

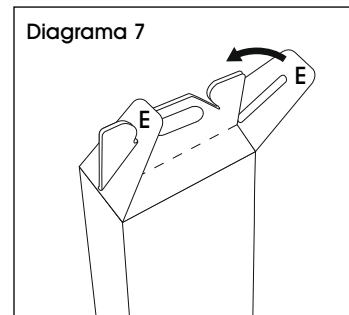
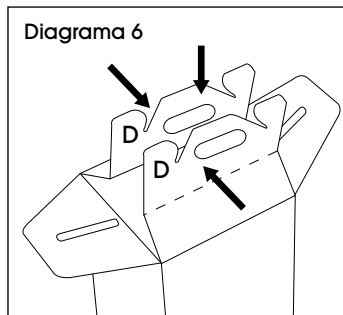

6. Empuje la solapa (F) hacia adentro para crear el orificio del asa. (Vea Diagrama 8)

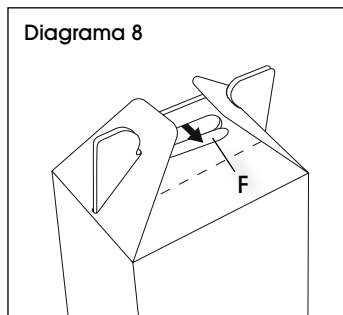

ULINE

800-295-5510
uline.mx

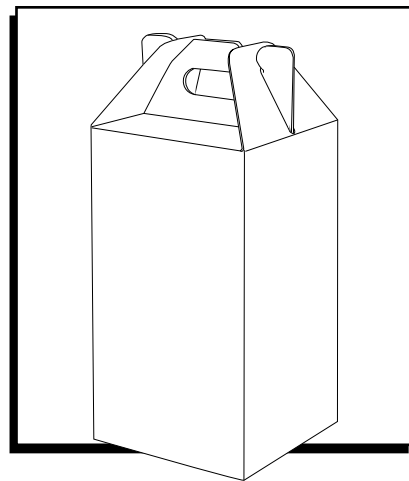

ASSEMBLAGE

1. Poussez les côtés à l'intérieur vers le centre pour ouvrir la boîte. Retournez-la à l'envers pour assembler le fond. (Voir Figure 1)

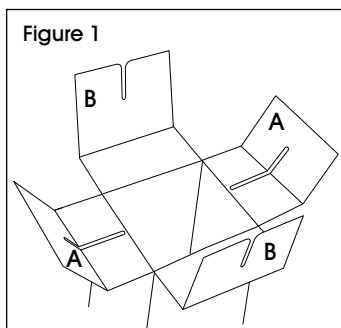

2. Abaissez les rabats (A) aux pliures et pliez-les vers l'intérieur de la boîte. Il doit y avoir un espace entre les deux côtés. (Voir Figures 2 et 3)

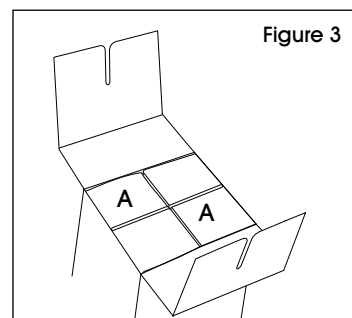
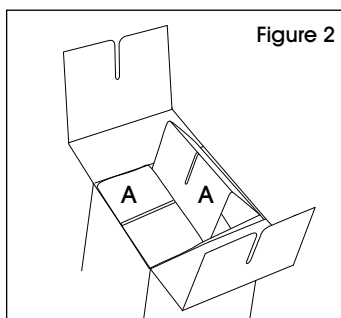

3. Abaissez les rabats (B) aux pliures et pliez-les en les insérant dans la fente au centre formée à l'étape 2. (Voir Figure 4)
4. Retournez la boîte à l'endroit. La boîte assemblée doit posséder quatre compartiments. (Voir Figure 5)

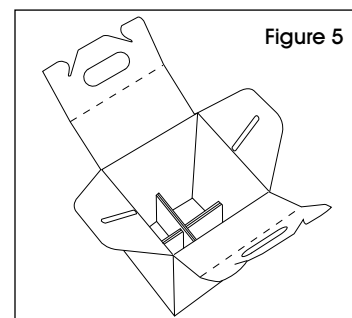
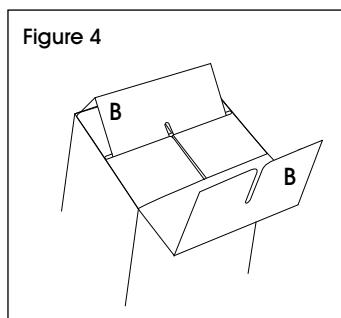

ASSEMBLAGE SUITE

5. Pour fermer le dessus, ramenez les deux côtés longs (D) ensemble. Poussez les côtés longs vers le bas pour qu'ils soient pliés au niveau des perforations. Faites glisser les languettes à fente latérales (E) sur les côtés longs pour les emboîter. (Voir Figures 6 et 7)

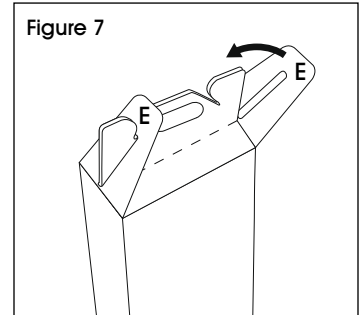
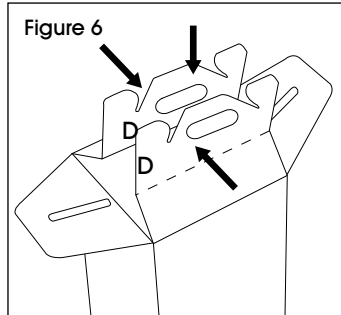

6. Empuje la solapa (F) hacia adentro para crear el orificio del asa. (Vea Diagrama 8)

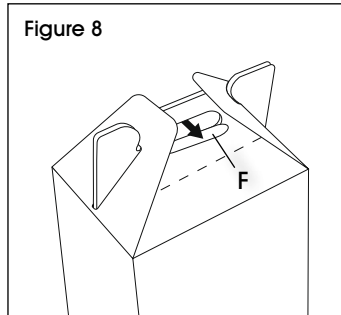

ULINE

1 800 295-5510
uline.ca