

**ULINE** S-108, S-12709, S-12928  
S-12929, S-12930, S-18507

1-800-295-5510  
uline.com

## METAL BUCKLES FOR POLY STRAPPING

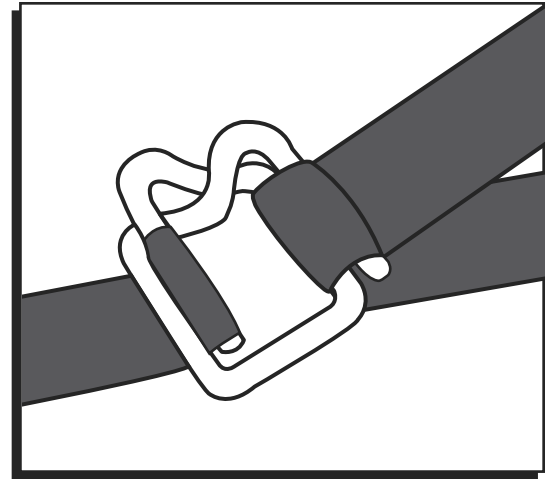

### THREADING INSTRUCTIONS

1. Insert end of strapping up through center of buckle and around open leg to form a loop. Pull top tight around leg. (See Figure 1)

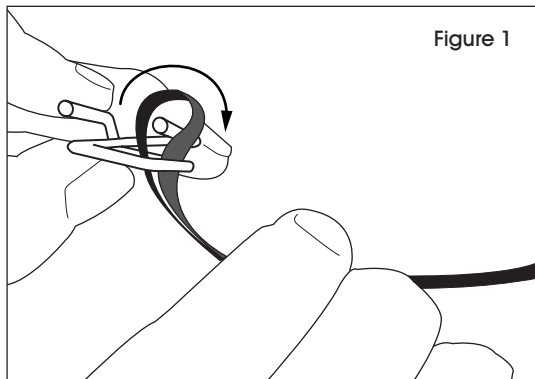

3. Pull both top ends of strapping in opposite directions to manually tighten. (See Figure 3)

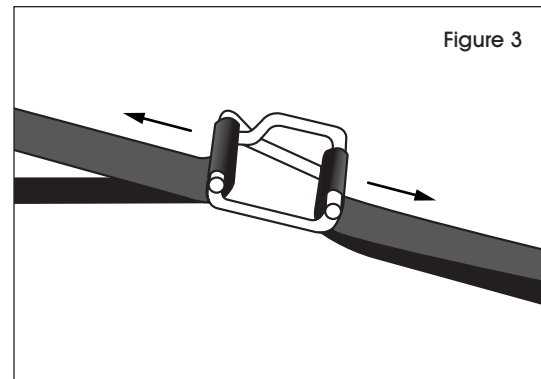

2. Wrap strapping around package. Loop strapping around remaining open leg of buckle. Pull loop tight around leg. (See Figure 2)

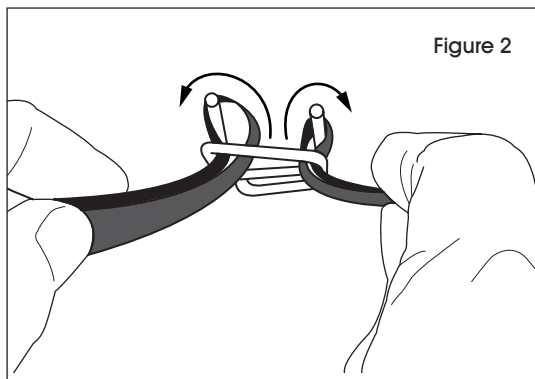

## HEBILLAS DE METAL PARA FLEJE DE POLIPROPILENO

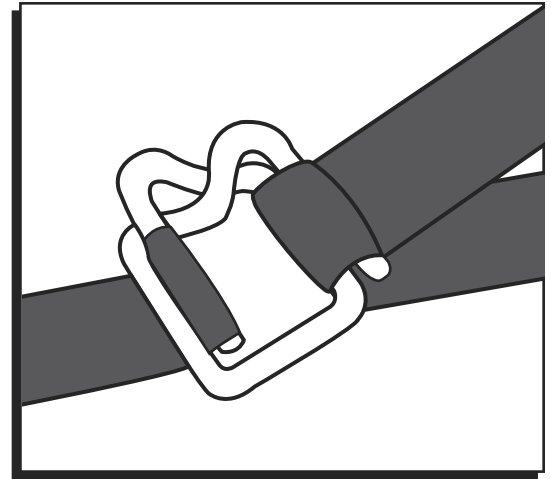

### INSTRUCCIONES DE ARMADO

1. Inserte el extremo del fleje hacia arriba a través del centro de la hebilla y alrededor de la pata abierta para formar un bucle. Estire bien de la parte superior alrededor de la pata. (Vea Diagrama 1)

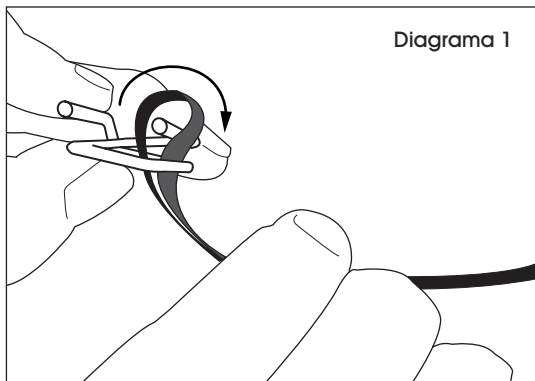

2. Envuelva el fleje alrededor del paquete. Haga un bucle con el fleje alrededor del extremo abierto restante de la hebilla. Estire bien del bucle alrededor de la pata. (Vea Diagrama 2)

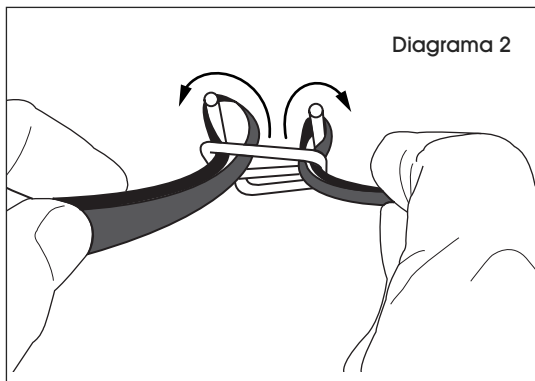

3. Jale de ambos extremos superiores del fleje en la dirección opuesta para apretarlos manualmente. (Vea Diagrama 3)

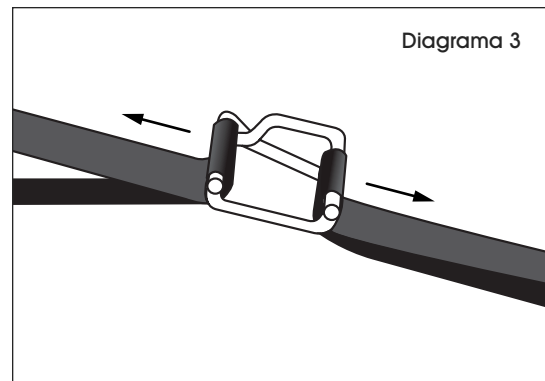

# BOUCLES EN MÉTAL POUR FEUILLARD EN POLYPROPYLENE

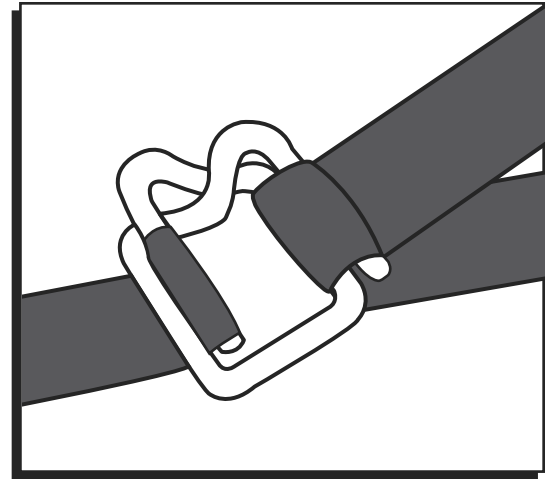

## INSTRUCTIONS D'ENFILAGE

1. Insérez l'extrémité du feuillard de cerclage à travers le centre de la boucle, vers le haut, puis autour de la patte ouverte formant ainsi un noeud. Tirez la partie supérieure fermement autour de la patte. (Voir Figure 1)

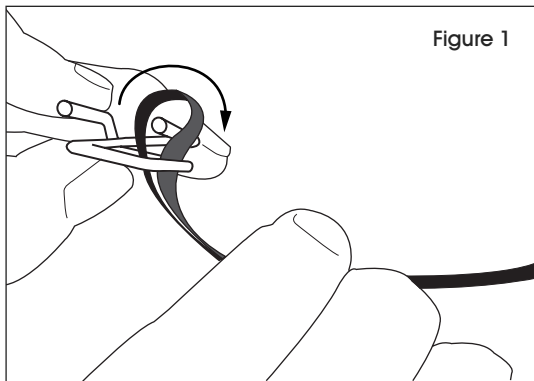

3. Tirez les deux extrémités supérieures du feuillard dans la direction opposée pour le serrer manuellement. (Voir Figure 3)

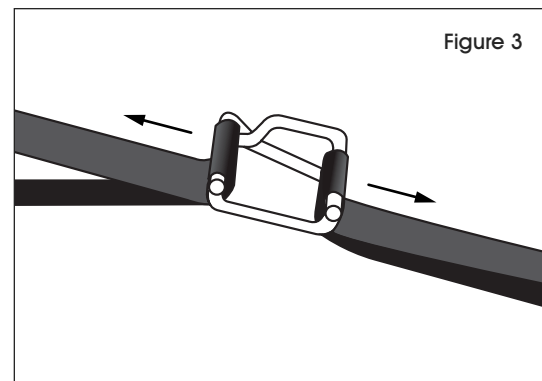

2. Enveloppez le feuillard autour du paquet. Placez le feuillard autour de l'autre patte ouverte de la boucle. Tirez fermement sur le noeud ayant été formé autour de la patte. (Voir Figure 2)

