

**ULINE** S-12896, S-12897  
S-12898

1-800-295-5510  
uline.com

# BUBBLE CORNER GUARDS

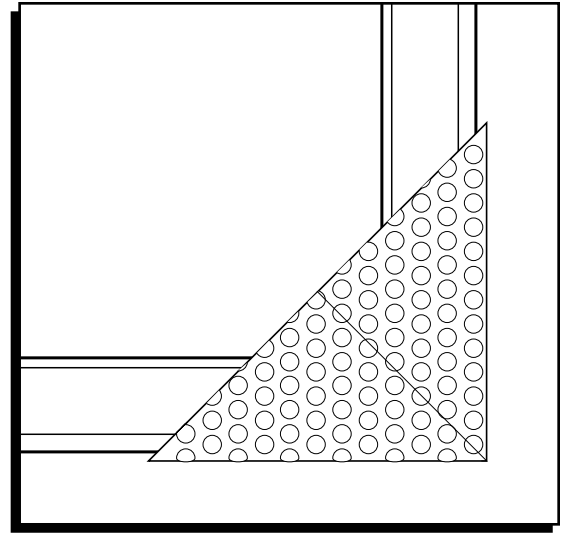

## INSTRUCTIONS

1. Tear bubble corner guard off the roll at the perforation. Grasp at the sealed edge. (See Figure 1)

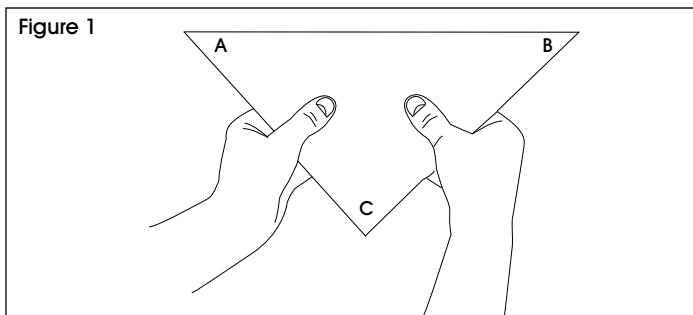

2. Press sealed edges inward to open the corner guard. (See Figure 2)

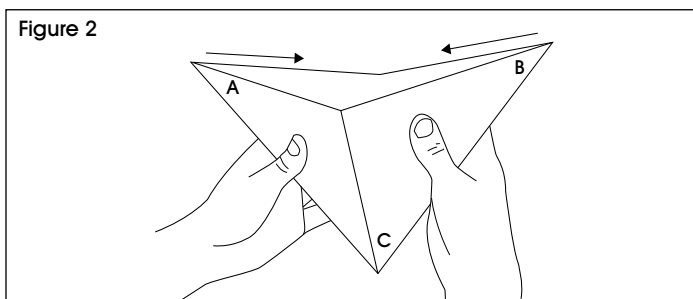

3. Fold points A and B into the corner guard until they touch point C. (See Figure 3)

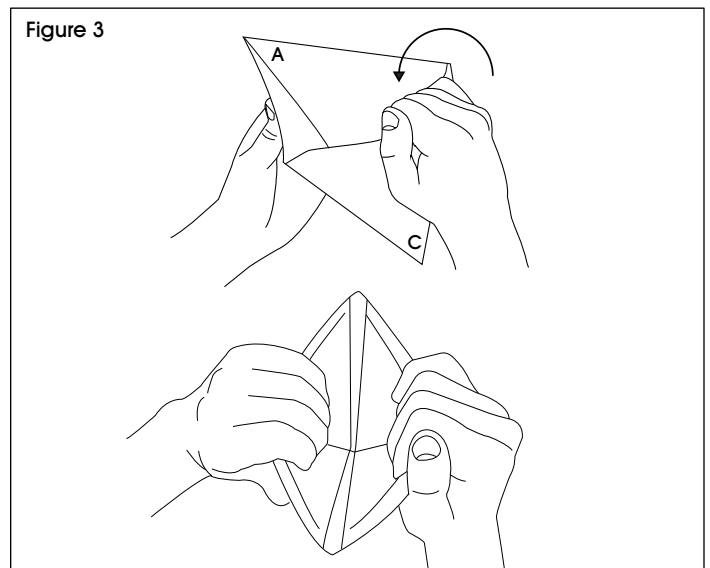

4. Apply to corner with seal seam on front and back of corner. (See Figure 4)

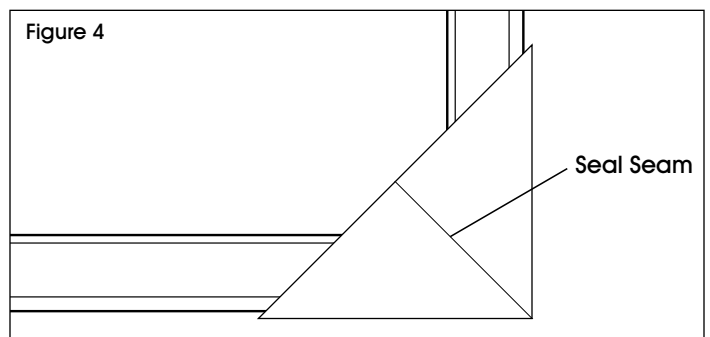

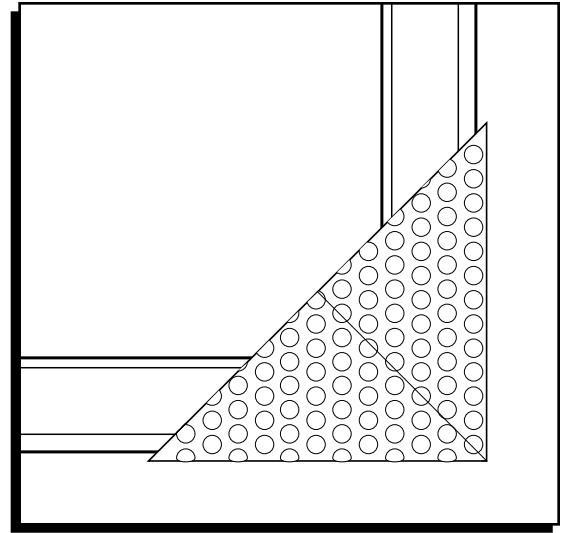
**ESQUINEROS DE  
BURBUJA PARA  
PROTECCIÓN****INSTRUCCIONES**

1. Arranque esquinero de burbuja para protección del rollo por la línea perforada. Sosténgalo por el borde sellado. (Vea Diagrama 1)

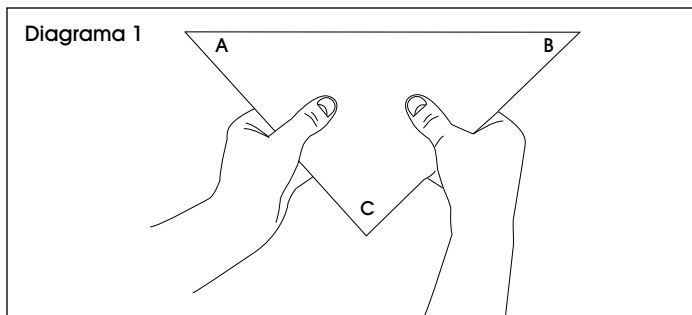

2. Presione los bordes sellados hacia adentro para abrir el esquinero. (Vea Diagrama 2)

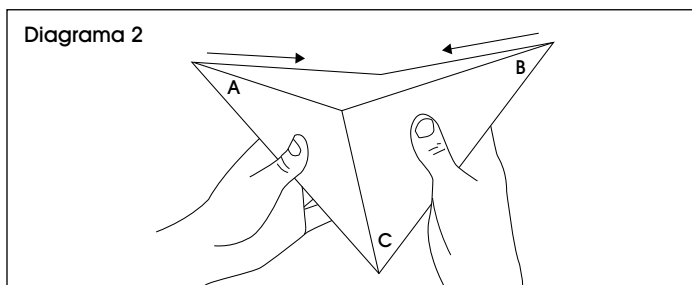

3. Doble los puntos A y B hacia adentro del esquinero hasta que toquen el punto C. (Vea Diagrama 3)

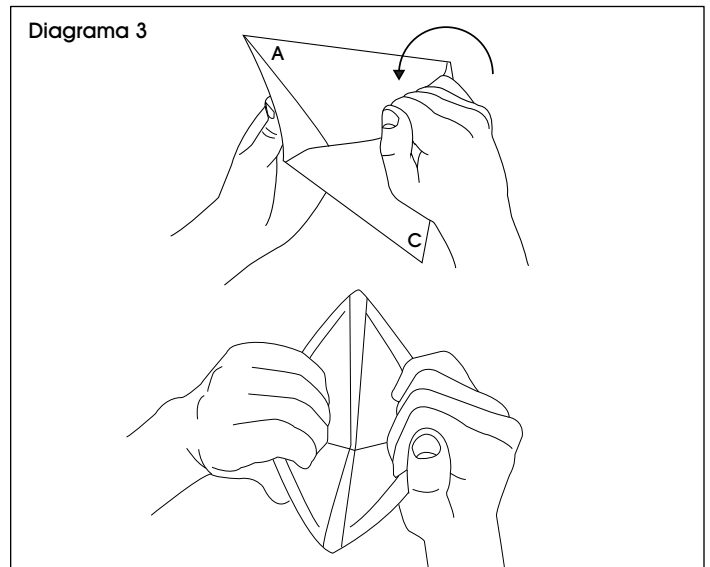

4. Colóquelo en la esquina con la costura sellada delante y detrás de la esquina. (Vea Diagrama 4)

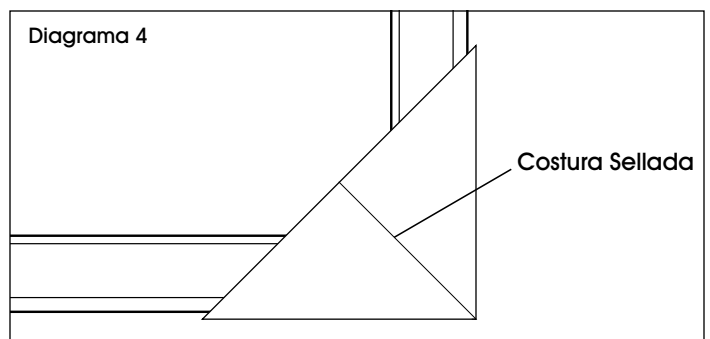

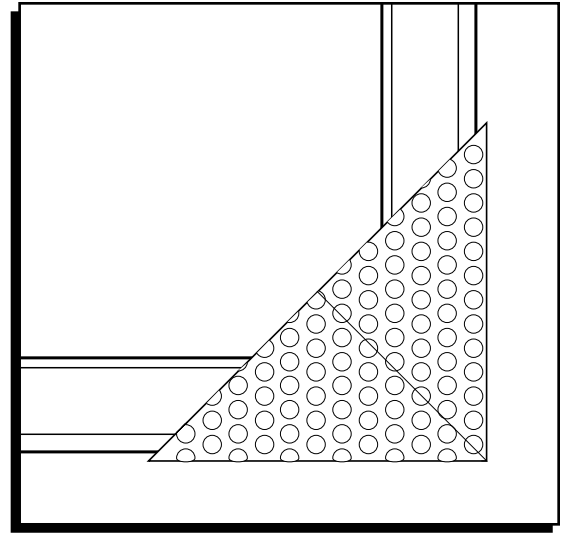

## INSTRUCTIONS

1. Retirez le protecteur de coins à bulles du rouleau à la ligne perforée. Saisissez-le par le bord scellé. (Voir Figure 1)

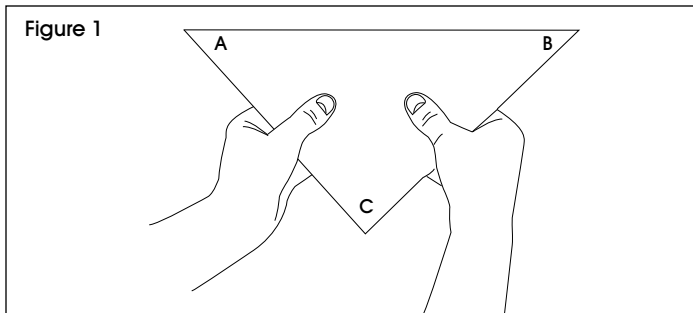

2. Poussez les bords scellés vers l'intérieur pour ouvrir le protecteur de coins. (Voir Figure 2)

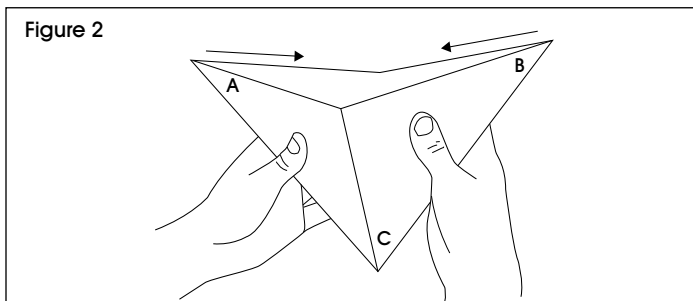

3. Pliez les points A et B vers l'intérieur du protecteur de coins jusqu'à ce qu'ils touchent le point C. (Voir Figure 3)

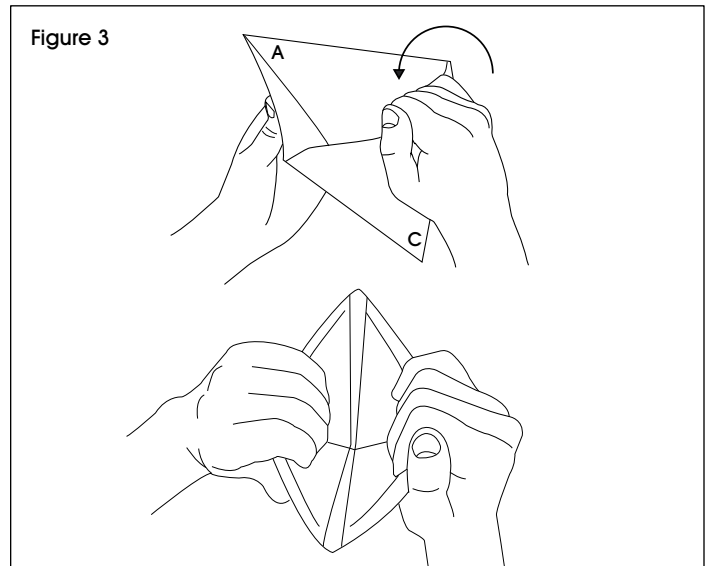

4. Placez-le protecteur sur le coin de telle façon que la pliure se retrouve à l'avant et à l'arrière du coin. (Voir Figure 4)

