

ULINE S-13283

MOBILE ROLL FILE – 50 COMPARTMENT

1-800-295-5510
 uline.com

TOOL NEEDED



Allen Wrench
 (included)

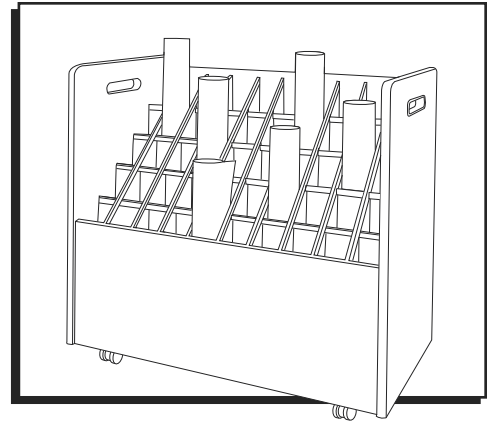

PARTS

PARTS

#	DESCRIPTION	QTY.
A	Back Panel	1
B	Left Side Panel	1
C	Right Side Panel	1
D	Bottom Panel	1
E	Front Panel	1
F	Small Rectangular Partition	1
G	Medium Rectangular Partition	1
H	Large Rectangular Partition	1
I	Extra Large Rectangular Partition	1
J	Triangular Partition	9
K	Open Channel	4
L	Closed Channel	9

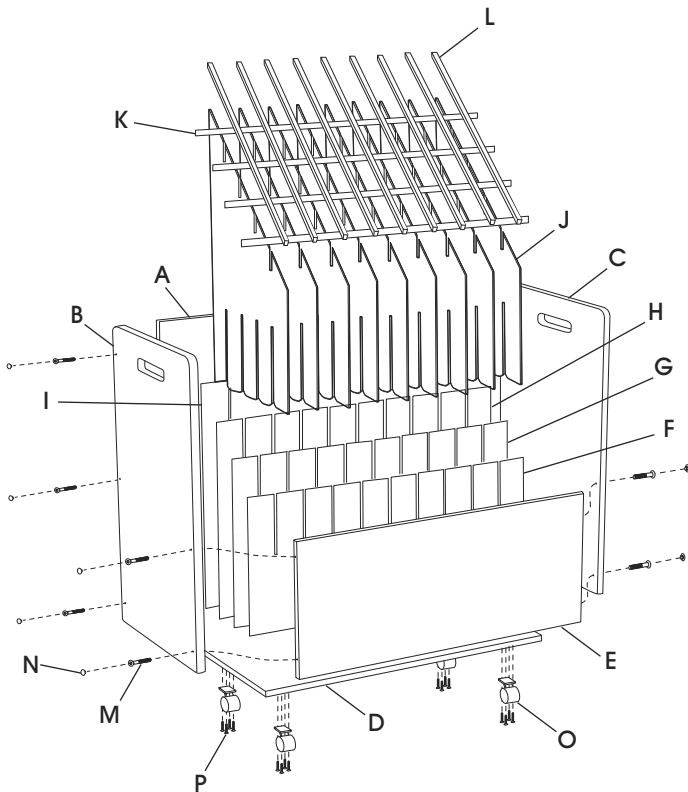

Hardware Kit

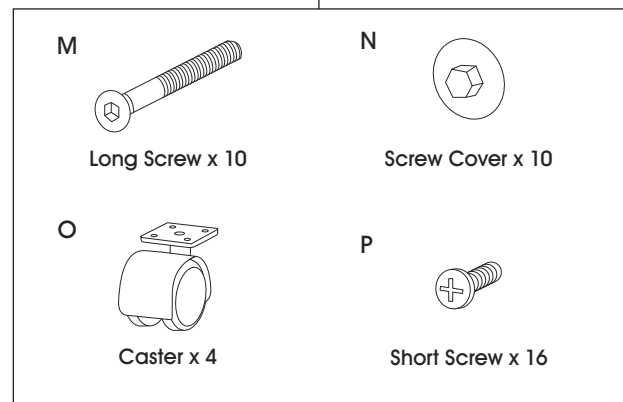

ASSEMBLY

1. Align side panels (B and C) to the back panel (A). Attach using long screws (M) and screw covers (N). (See Figure 1)

 **NOTE:** Larger recesses for screw face toward the outer side.

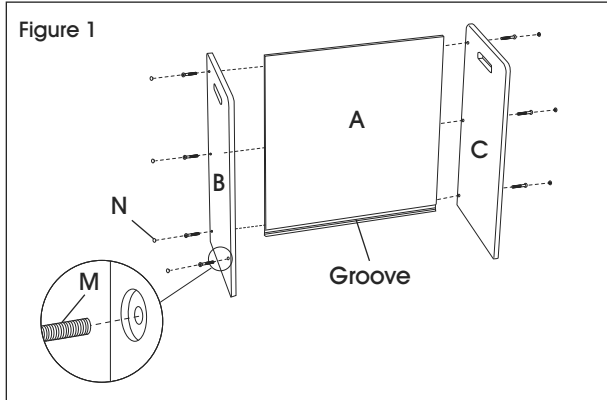

2. Slide bottom panel (D) in to rest in groove of back panel (A). (See Figure 2)

 **NOTE:** Pre-drilled holes should be facing outside for casters in step 4.

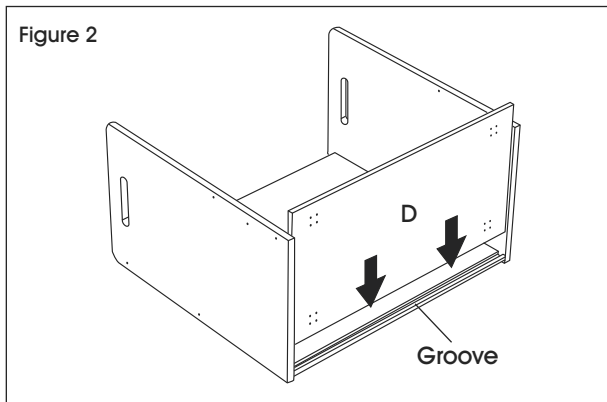

3. Place front panel (E) into position. Bottom panel (D) will fit into groove in panel (E). (See Figure 3)
4. Screw side panels to front panel (E) using long screws (M) and screw covers (N). (See Figure 3)

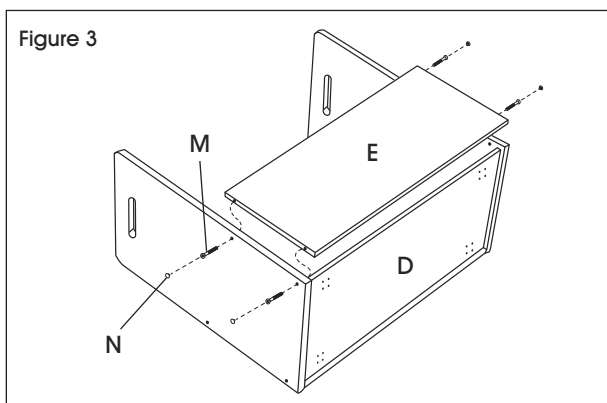

5. Attach casters (O) to bottom panel (D) with short screws (P) using pre-drilled holes as a guide. (See Figure 4)

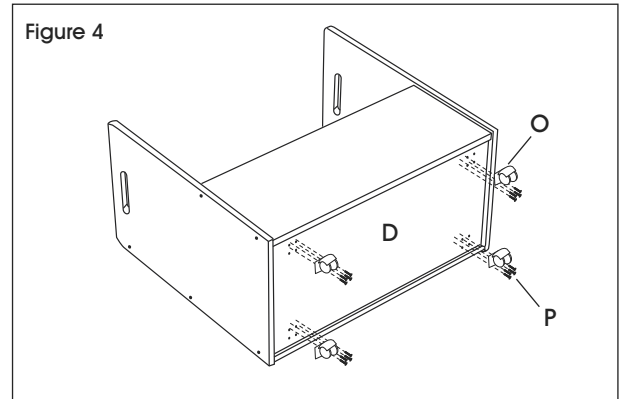

6. Put rectangular partitions (F, G, H, I) in place. Tallest in back, shortest in front. (See Figure 5)
7. Slide a triangular partition (J) into the slot of rectangular partitions (F, G, H, I). Repeat up to eight times or as desired. (See Figure 5)

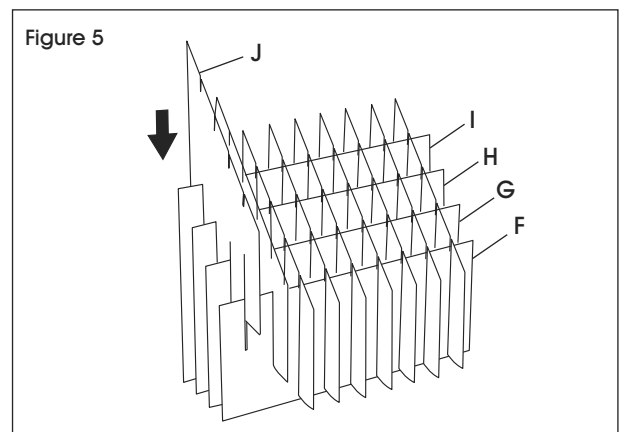

8. Place open channels (K) on partitions horizontally. (See Figure 6)

 **NOTE:** Open channels have two squared ends.

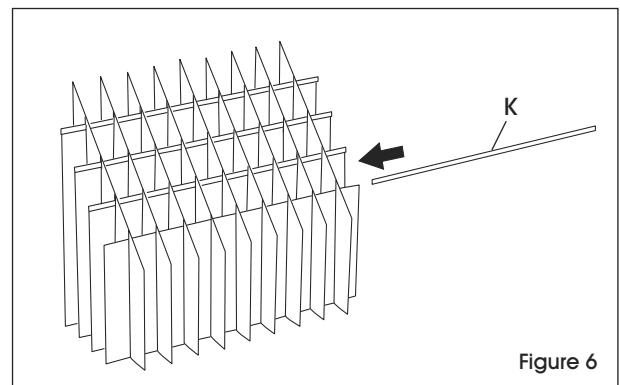

ASSEMBLY CONTINUED

9. Place closed channels (L) on partitions vertically.
(See Figure 7)

 **NOTE:** Closed channels have one angled end.

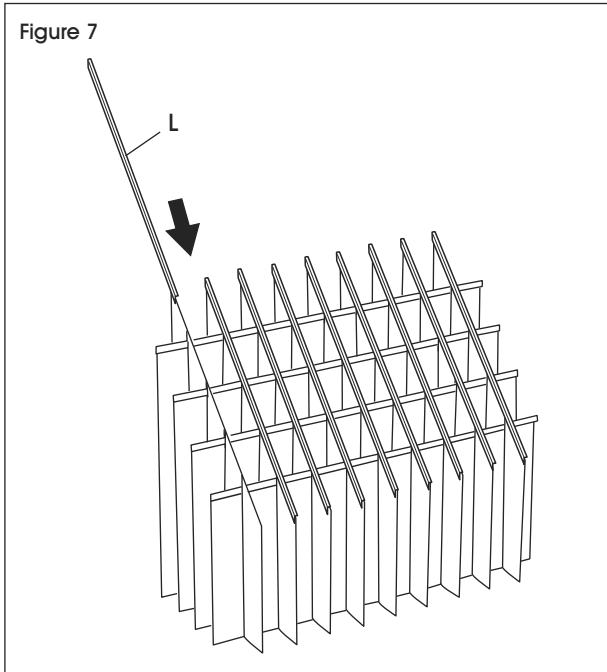
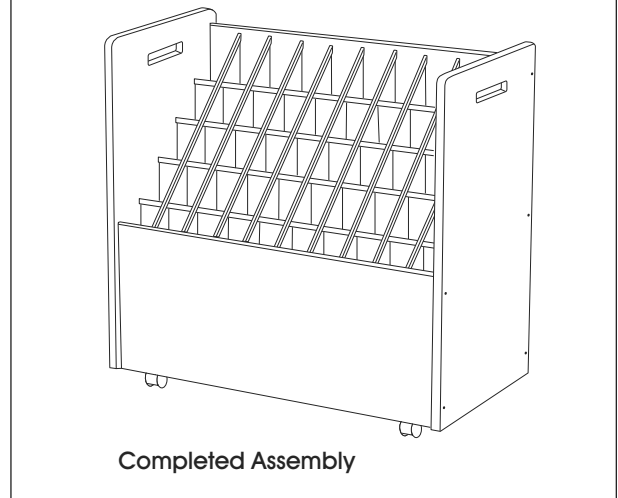
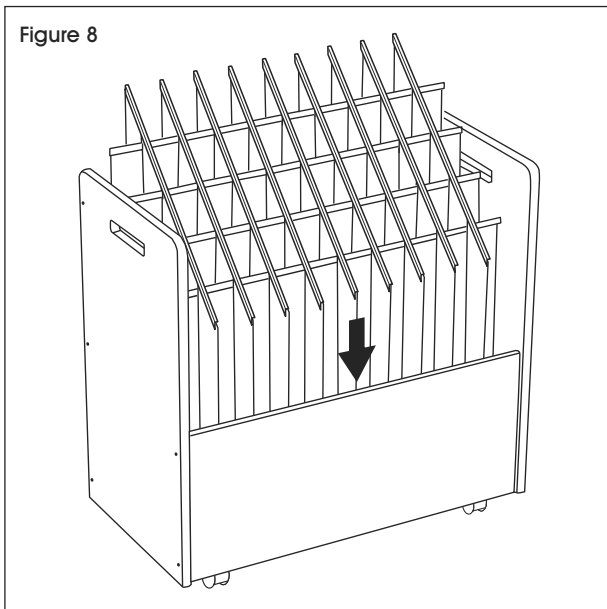

Figure 9



10. Place assembled compartments inside the base.
(See Figures 8-9)



ULINE

1-800-295-5510
uline.com

ULINE S-13283

ARCHIVERO MÓVIL PARA ROLLOS – 50 COMPARTIMENTOS

800-295-5510

uline.mx

HERRAMIENTA NECESARIA



Llave Allen
(incluida)

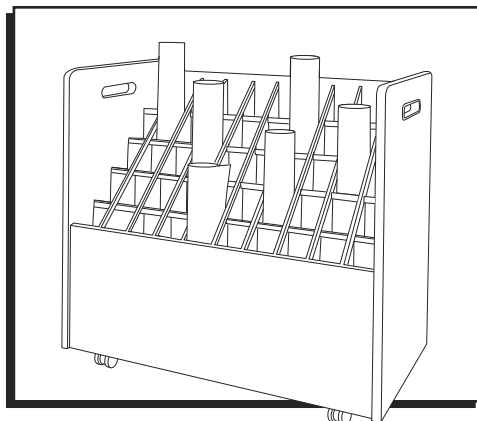

PARTES

PARTES

#	DESCRIPCIÓN	CANT.
A	Panel Posterior	1
B	Panel Lateral Izquierdo	1
C	Panel Lateral Derecho	1
D	Panel Inferior	1
E	Panel Frontal	1
F	Separador Rectangular Chico	1
G	Separador Rectangular Mediano	1
H	Separador Rectangular Grande	1
I	Separador Rectangular Extragrande	1
J	Separador Triangular	9
K	Canal Abierto	4
L	Canal Cerrado	9

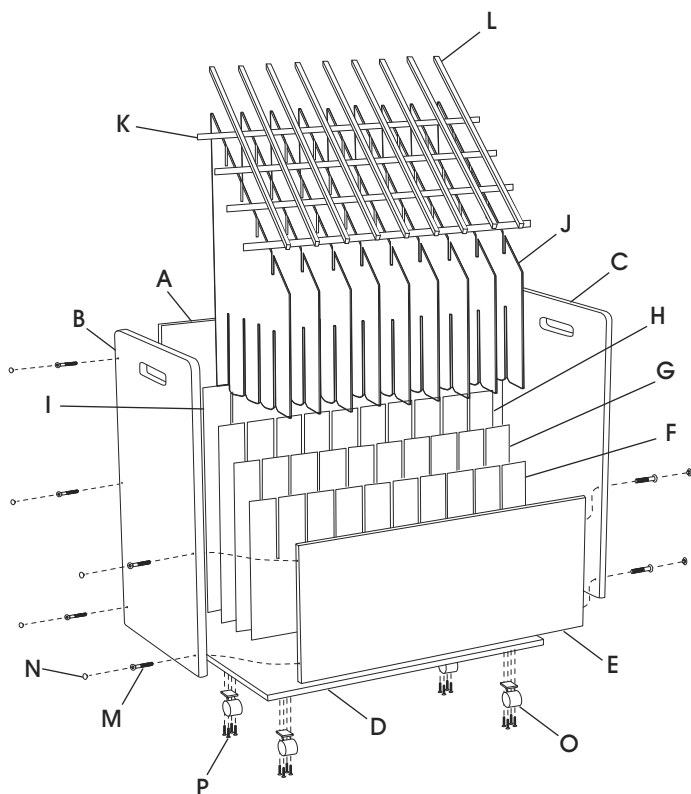

Kit de Tornillería

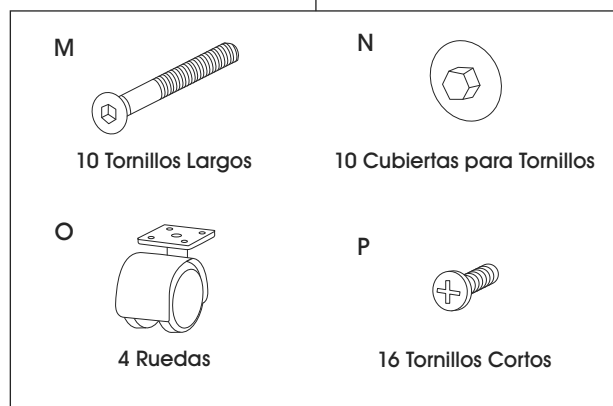

ENSAMBLE

1. Alinee los paneles laterales (B y C) al panel posterior (A). Fije con los tornillos largos (M) y las cubiertas para tornillos (N). (Vea Diagrama 1)

 **NOTA:** Los huecos más grandes para los tornillos deben mirar hacia afuera.

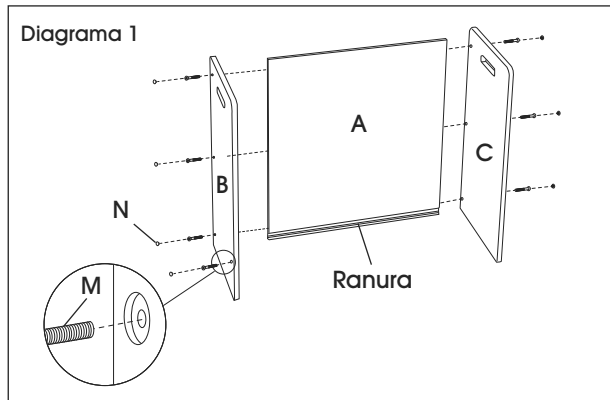

2. Deslice el panel inferior (D) hacia adentro para que descansa en la ranura del panel posterior (A). (Vea Diagrama 2)

 **NOTA:** Los orificios preperforados deben mirar hacia afuera para instalar las ruedas en el paso 4.

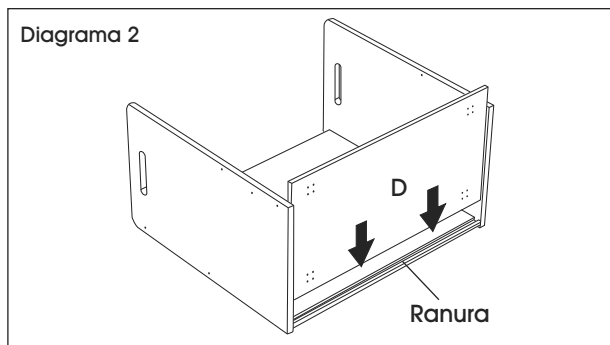

3. Coloque el panel frontal (E) en su lugar. El panel inferior (D) entrará en la ranura del panel (E). (Vea Diagrama 3)
4. Atornille los paneles laterales al panel frontal (E) utilizando tornillos largos (M) y las cubiertas para tornillos (N). (Vea Diagrama 3)

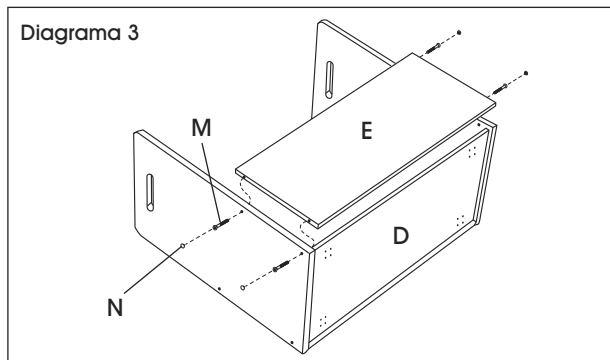

5. Fije las ruedas (O) al panel inferior (D) con los tornillos cortos (P) utilizando los orificios preperforados como guía. (Vea Diagrama 4)

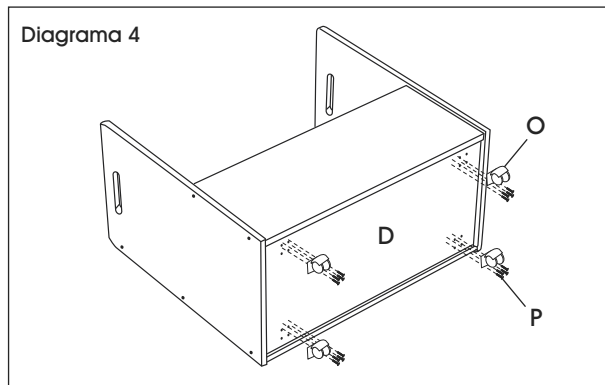

6. Coloque los separadores rectangulares (F, G, H, I) en su lugar. El más alto en la parte posterior, el más corto en el frente. (Vea Diagrama 5)
7. Deslice un separador triangular (J) en la ranura de los separadores rectangulares (F, G, H, I). Repita el proceso hasta ocho veces o como desee. (Vea Diagrama 5)

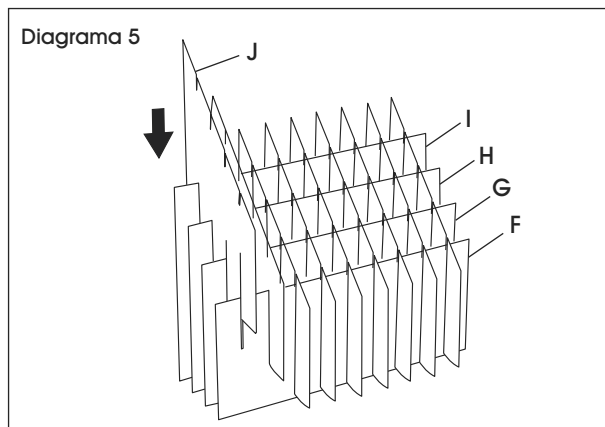

8. Coloque horizontalmente los canales abiertos (K) en los separadores. (Vea Diagrama 6)

 **NOTA:** Los canales abiertos cuentan con dos extremos cuadrados.

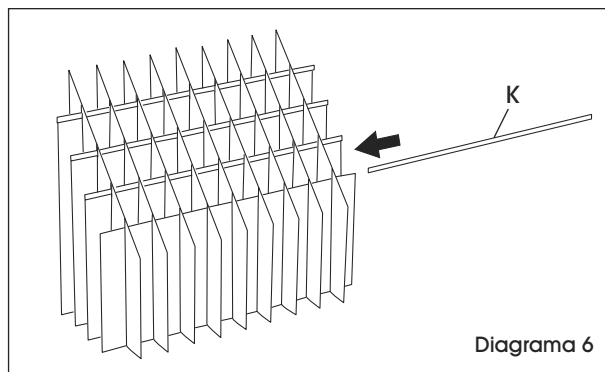

CONTINUACIÓN DE ENSAMBLE

9. Coloque verticalmente los canales cerrados (L) en los separadores. (Vea Diagrama 7)

 **NOTA:** Los canales cerrados cuentan con un extremo en ángulo.



Diagrama 9



10. Coloque los compartimientos ensamblados adentro de la base. (Vea Diagramas 8-9)

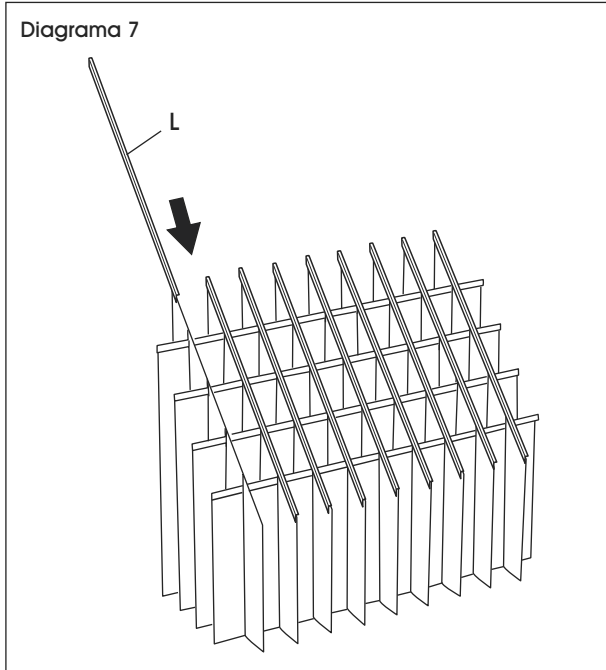
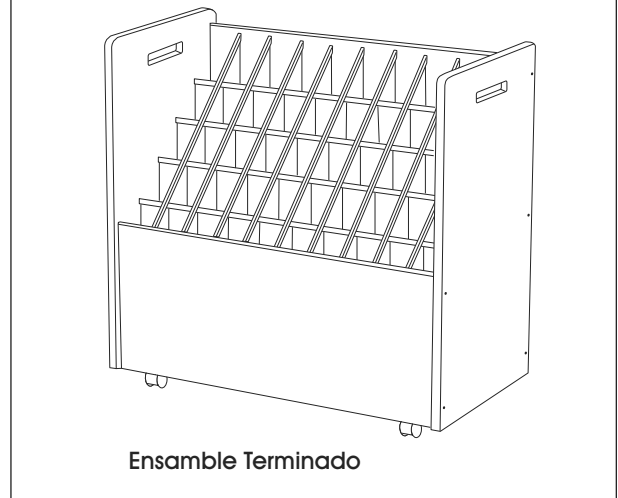
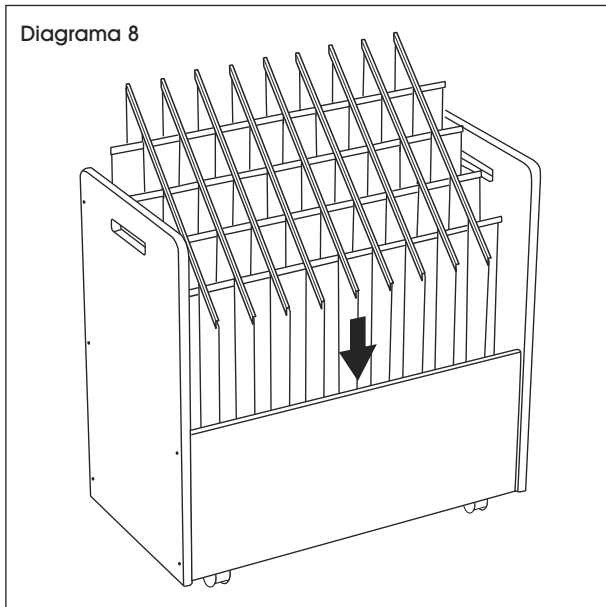

ULINE

800-295-5510
uline.mx

ULINE S-13283

CLASSEUR DE ROULEAUX MOBILE – 50 COMPARTIMENTS

1-800-295-5510

uline.ca

OUTIL REQUIS



Clé Allen
(inclus)

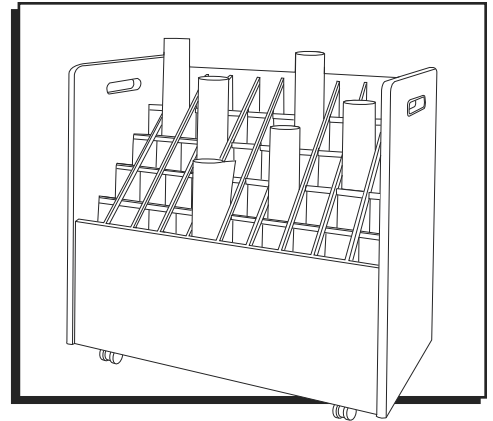

PIÈCES

PIÈCES

#	DESCRIPTION	QTÉ
A	Panneau arrière	1
B	Panneau latéral gauche	1
C	Panneau latéral droit	1
D	Panneau inférieur	1
E	Panneau avant	1
F	Cloison rectangulaire – Petit	1
G	Cloison rectangulaire – Moyen	1
H	Cloison rectangulaire – Grand	1
I	Cloison rectangulaire – Très grand	1
J	Cloison triangulaire	9
K	Profilé ouvert	4
L	Profilé fermé	9

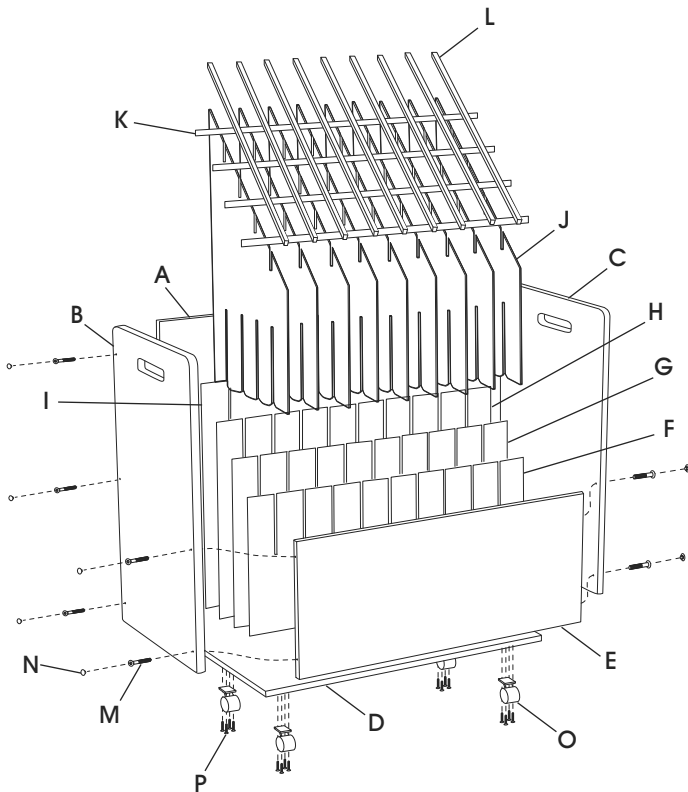

Matériel de fixation

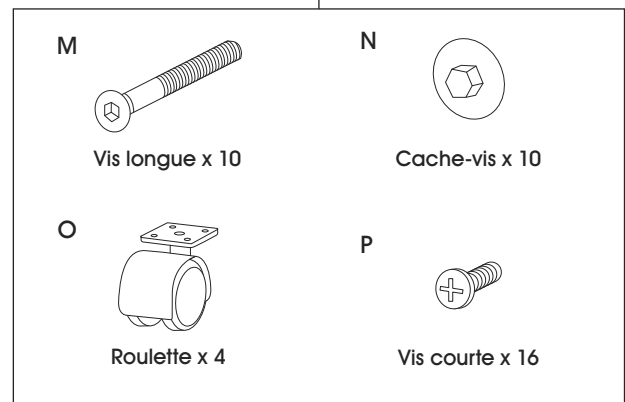

MONTAGE

1. Alignez les panneaux latéraux (B et C) sur le panneau arrière (A). Fixez-les avec les vis longues (M) et les cache-vis (N). (Voir Figure 1)

 **REMARQUE :** Les grands renforcements pour vis sont orientés vers le côté extérieur.

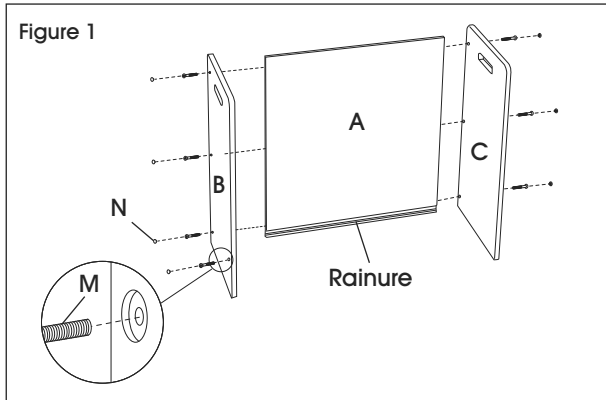

2. Faites glisser le panneau inférieur (D) en le faisant reposer dans la rainure du panneau arrière (A). (Voir Figure 2)

 **REMARQUE :** Les trous prépercés doivent être orientés vers l'extérieur pour les roulettes à l'étape 4.

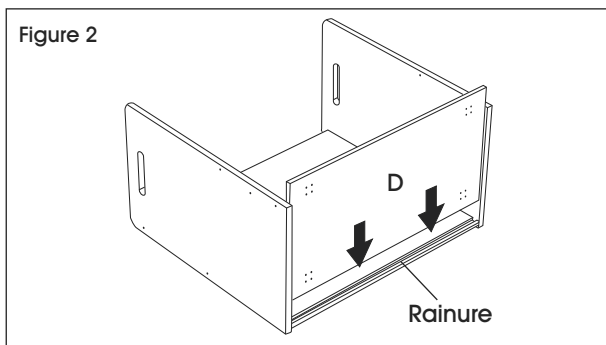

3. Placez le panneau avant (E) en position. Le panneau inférieur (D) s'insère dans la rainure du panneau (E). (Voir Figure 3)
4. Fixez les panneaux latéraux sur le panneau avant (E) avec les vis longues (M) et les cache-vis (N). (Voir Figure 3)

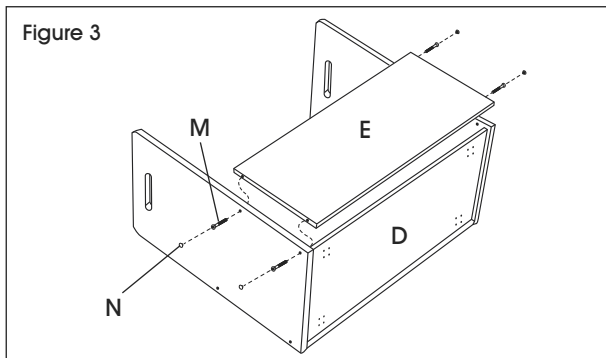

5. Fixez les roulettes (O) sur le panneau inférieur (D) avec les vis courtes (P) en utilisant les trous prépercés comme guide. (Voir Figure 4)

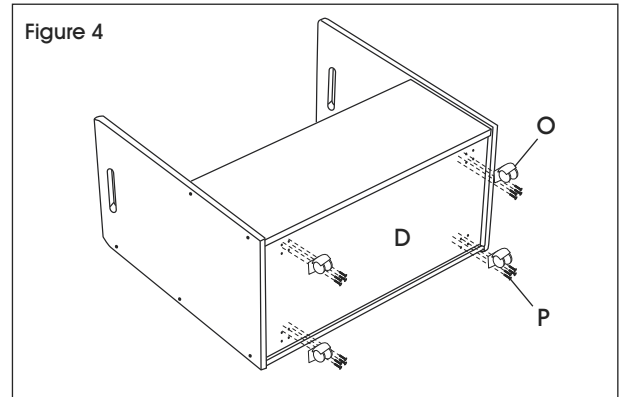

6. Mettez en place les cloisons rectangulaires (F, G, H, I). La plus grande à l'arrière, la plus petite à l'avant. (Voir Figure 5)
7. Faites glisser une cloison triangulaire (J) dans la fente des cloisons rectangulaires (F, G, H, I). Répétez l'opération huit fois ou selon les besoins. (Voir Figure 5)

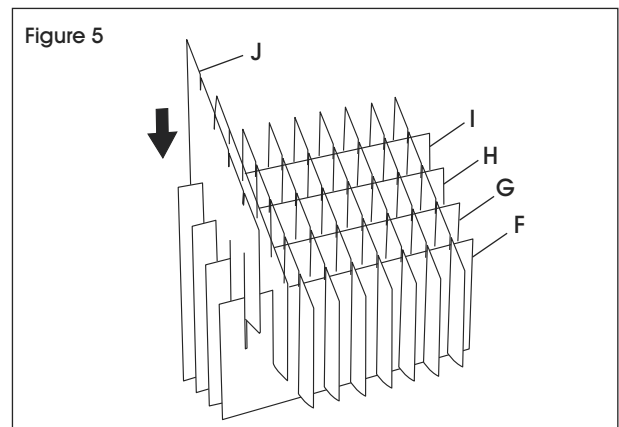

8. Placez horizontalement les profilés ouverts (K) sur les cloisons. (Voir Figure 6)

 **REMARQUE :** Les profilés ouverts ont deux extrémités carrées.

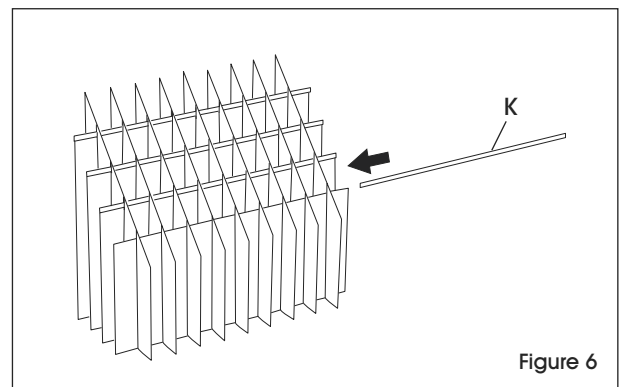

MONTAGE SUITE

9. Placez verticalement les profilés fermés (L) sur les cloisons. (Voir Figure 7)

 **REMARQUE :** Les profilés fermés ont une extrémité en angle.

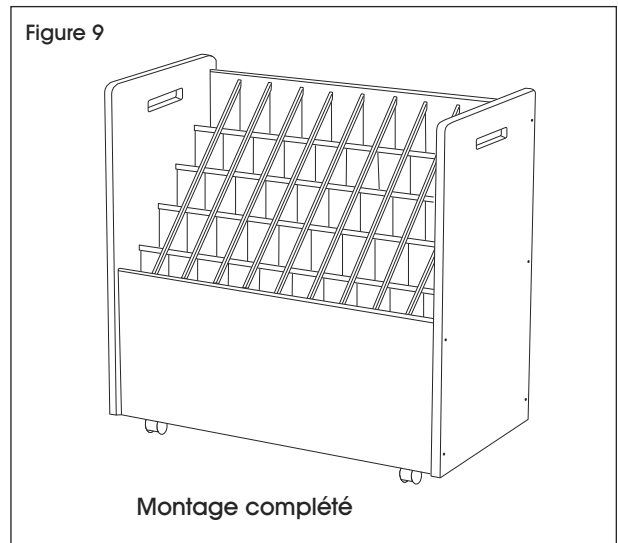
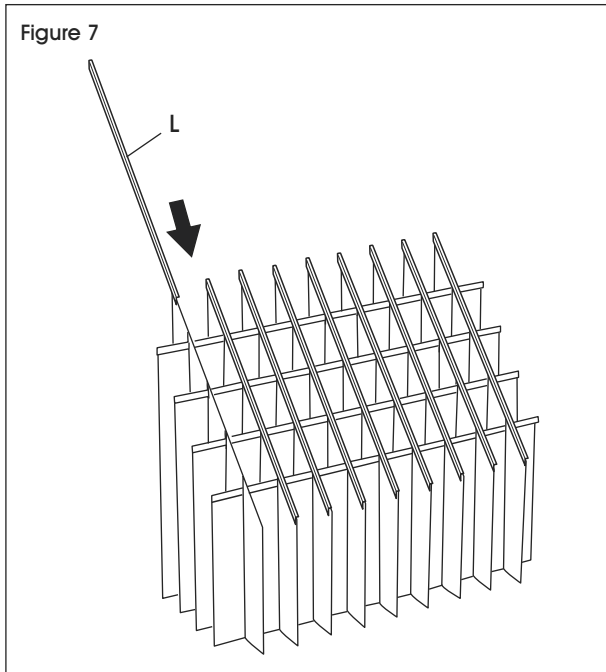

10. Placez les compartiments assemblés à l'intérieur de la base. (Voir Figures 8 et 9)

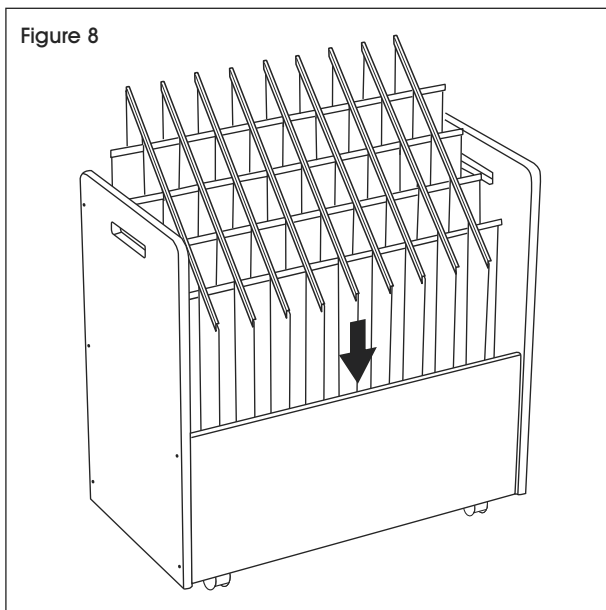

ULINE

1-800-295-5510
uline.ca