

# ULINE S-15024 DVD/CD STORAGE BOX

1-800-295-5510  
uline.com

Para Español, vea páginas 3-4.  
Pour le français, consulter les pages 5-6.

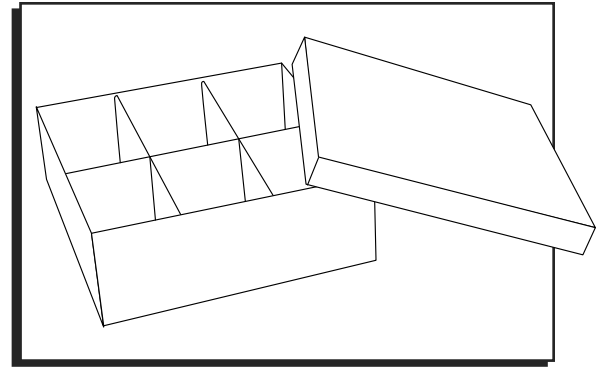

## LID ASSEMBLY

1. Fold A and B panels inward. (See Figure 1)

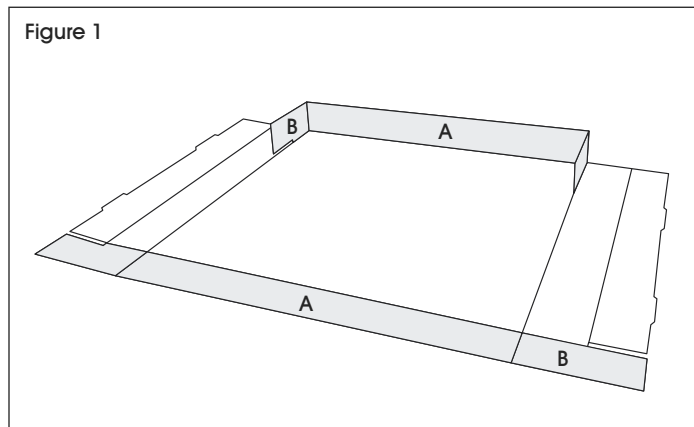

2. Fold C panels up and D panels over B panels and into slots. (See Figure 2)

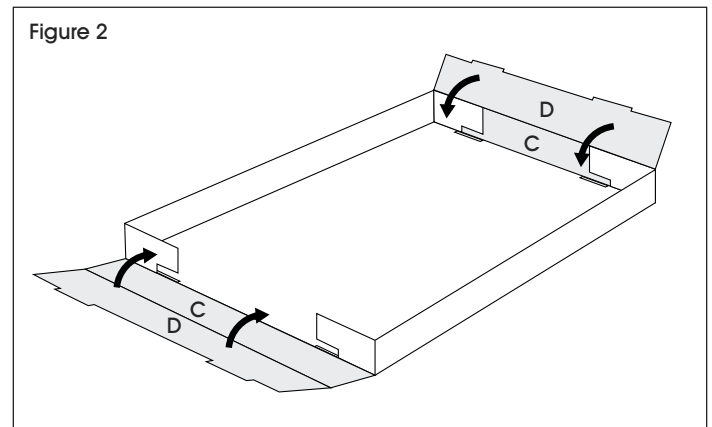

## DIVIDERS ASSEMBLY

1. Punch out holes in center divider, and fold divider in half. (See Figure 3)

2. Fold flanges at end of divider. (See Figure 4)

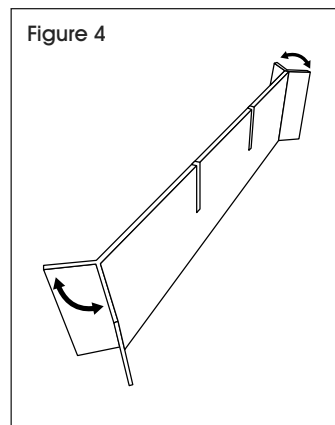
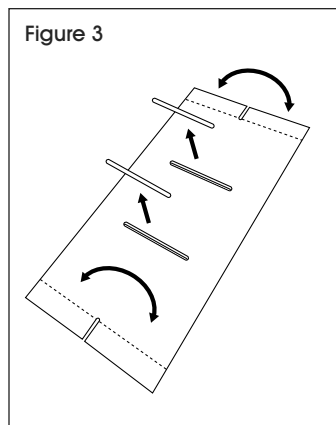

3. Repeat steps 1-2 for remaining dividers.

4. Assemble dividers. (See Figure 5)

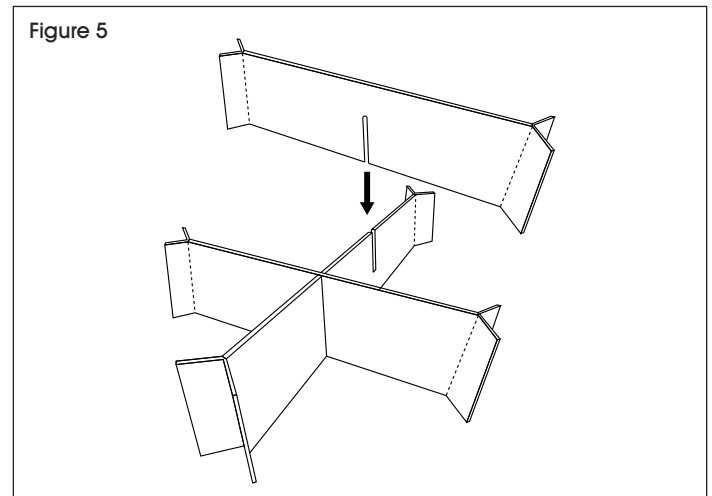

# BOX ASSEMBLY

1. Fold E and F panels up, then F panels inward.  
(See Figure 6)

Figure 6

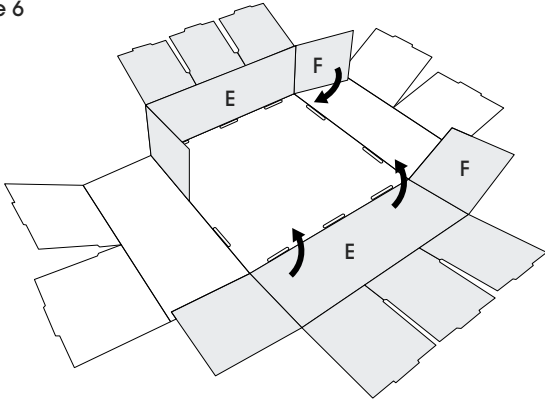

3. Fold H and I panels into slots at bottom of box.  
(See Figure 8)

Figure 8

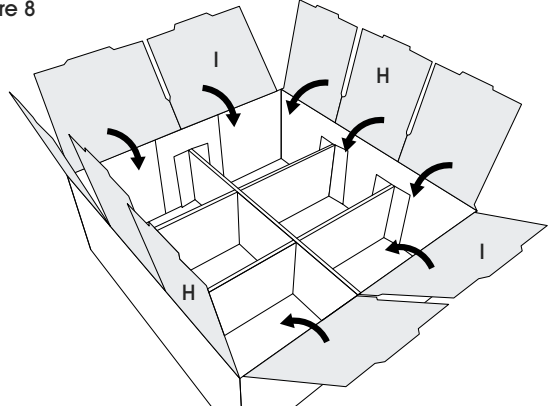

2. Fold G and H panels up. Place divider assembly inside box. (See Figure 7)

Figure 7

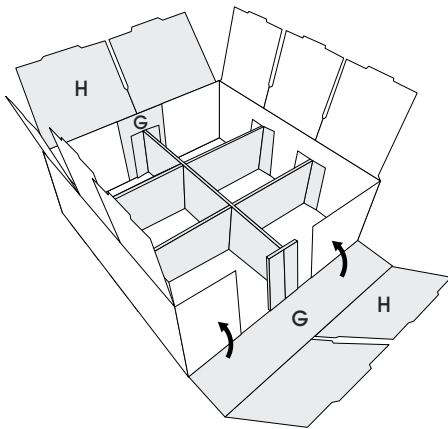

4. Place lid over box.

Completed Assembly

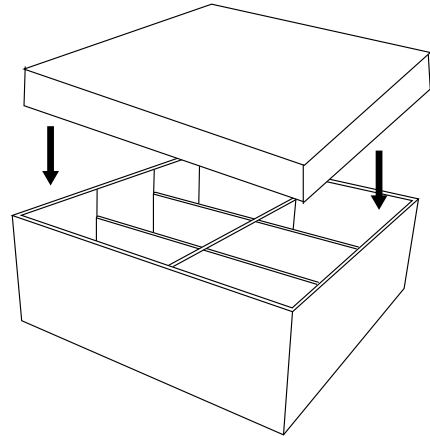

**ULINE** S-15024

800-295-5510  
uline.mx

# CAJA DE ALMACENAMIENTO PARA DVD/CD

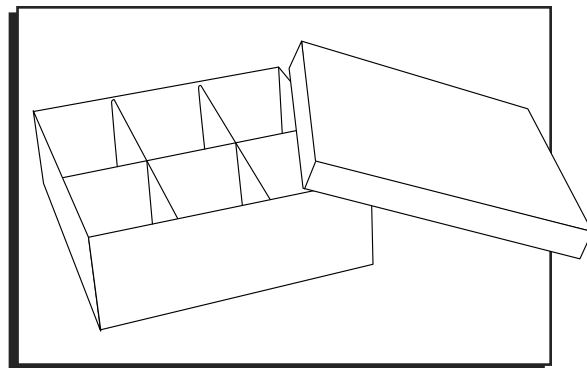

## ENSAMBLE DE LA TAPA

1. Doble los paneles A y B hacia adentro.  
(Vea Diagrama 1)

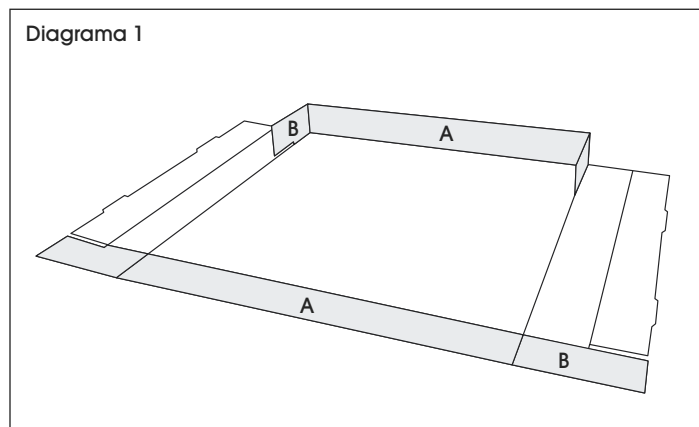

2. Doble los paneles C hacia arriba y los paneles D sobre los paneles B e insérteles en las ranuras.  
(Vea Diagrama 2)

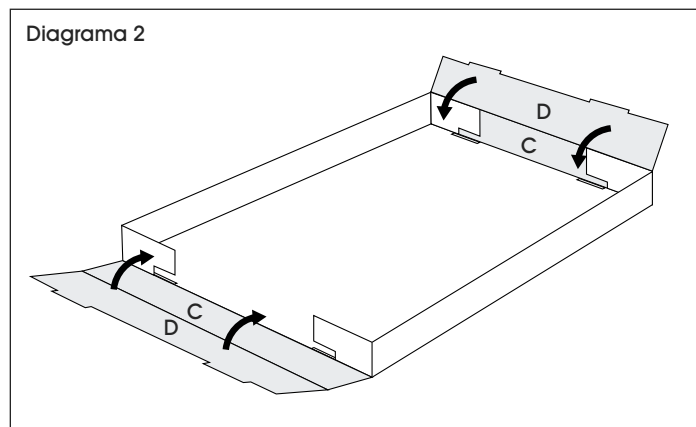

## ENSAMBLE DE LOS SEPARADORES

1. Perfore los orificios en el separador central y dóblelo a la mitad. (Vea Diagrama 3)
2. Doble los rebordes en los extremos del separador.  
(Vea Diagrama 4)

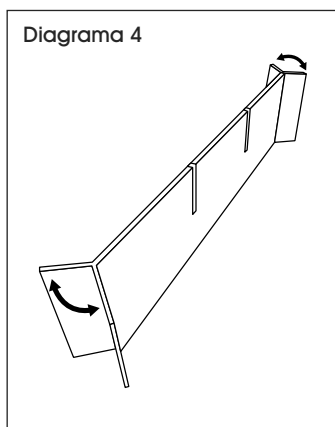
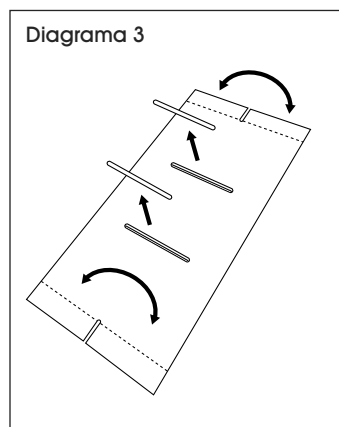

3. Repita los pasos para los separadores restantes 1-2.
4. Ensamble los separadores. (Vea Diagrama 5)

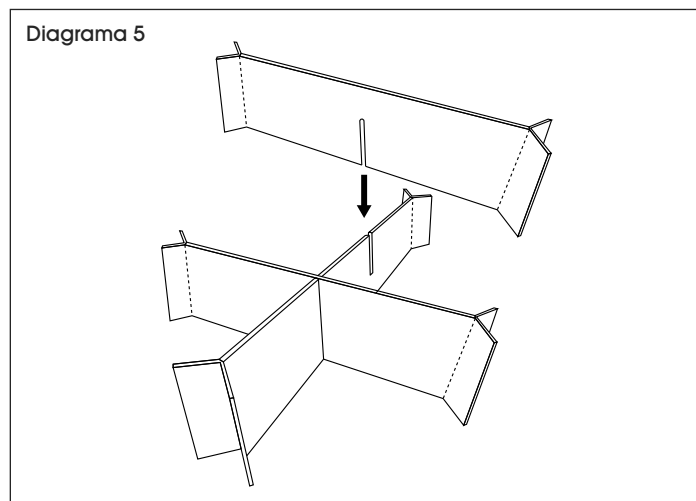

# ENSAMBLE DE LA CAJA

1. Doble los paneles E y F hacia arriba y después los paneles F hacia adentro. (Vea Diagrama 6)

Diagrama 6

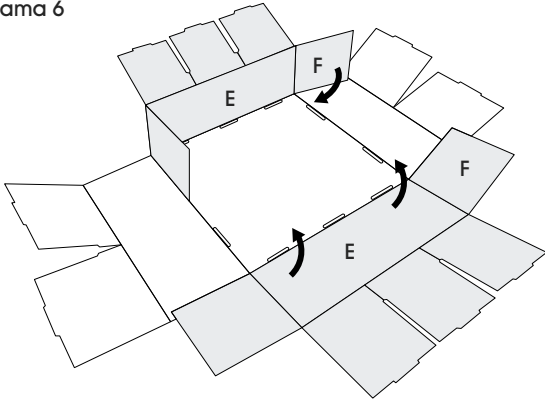

3. Doble los paneles H e I hacia las ranuras en la parte inferior de la caja. (Vea Diagrama 8)

Diagrama 8

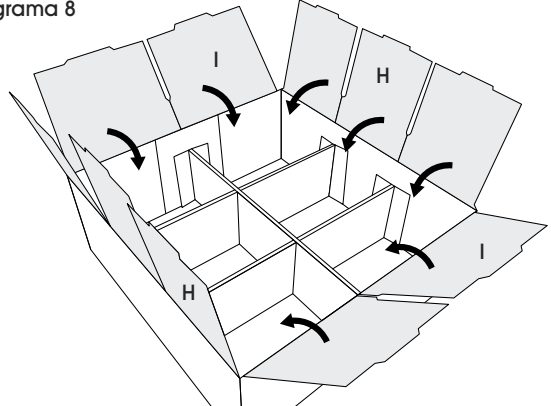

2. Doble los paneles G y H hacia arriba. Coloque el ensamble de separadores adentro de la caja. (Vea Diagrama 7)

Diagrama 7

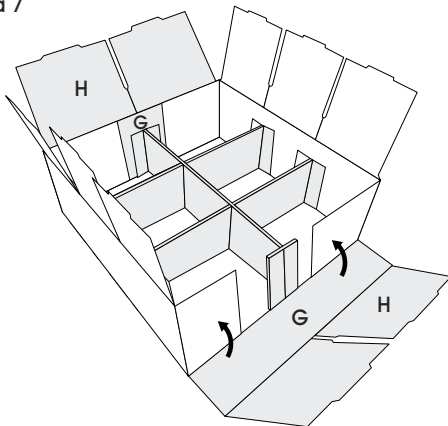

4. Coloque la tapa sobre la caja.

Ensamble Terminado

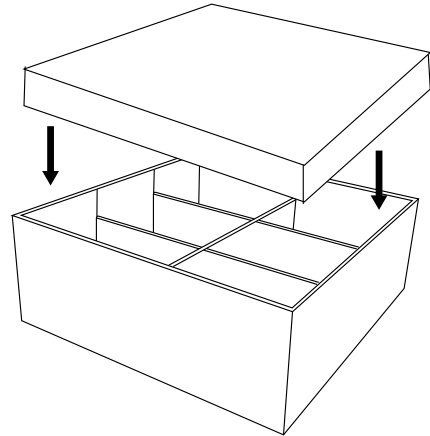

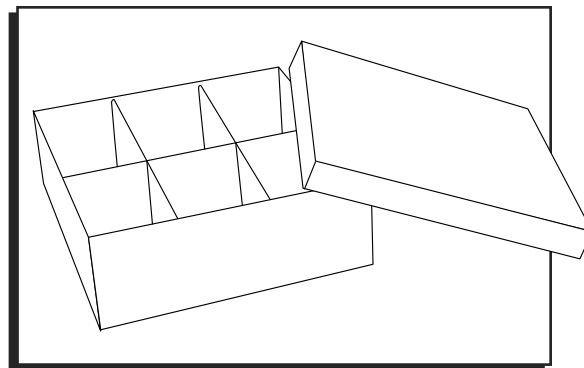

## ASSEMBLAGE DU COUVERCLE

1. Pliez les panneaux A et B vers l'intérieur. (Voir Figure 1)

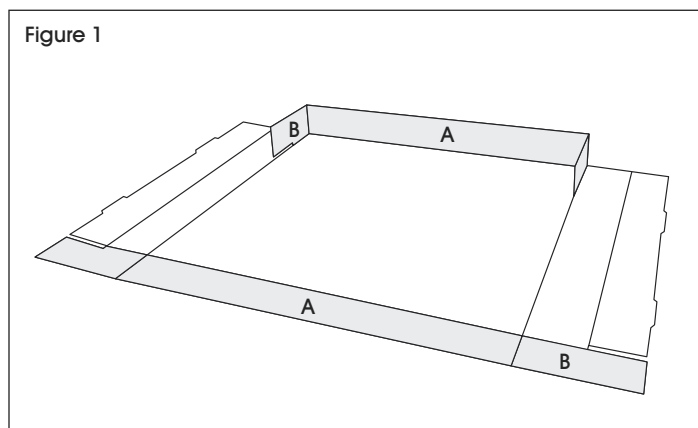

2. Pliez les panneaux C vers le haut et les panneaux D sur les panneaux B et insérez-les dans les fentes. (Voir Figure 2)

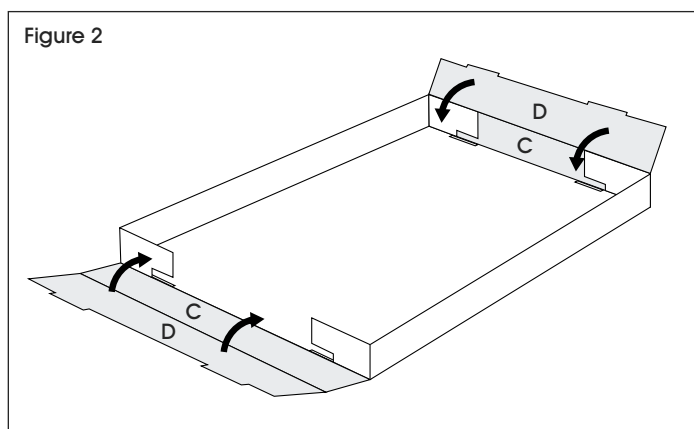

## ASSEMBLAGE DES SÉPARATEURS

1. Perforez les trous du séparateur central et pliez le séparateur en deux. (Voir Figure 3)

2. Pliez les rabats à l'extrémité du séparateur. (Voir Figure 4)

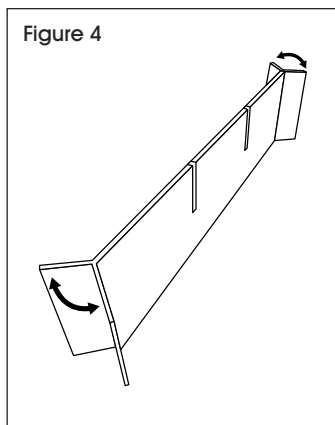
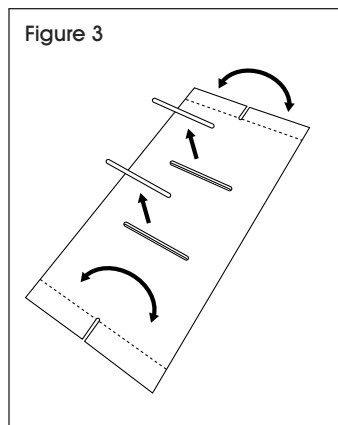

3. Répétez les étapes 1 et 2 pour les autres séparateurs.

4. Assemblez les séparateurs. (Voir Figure 5)

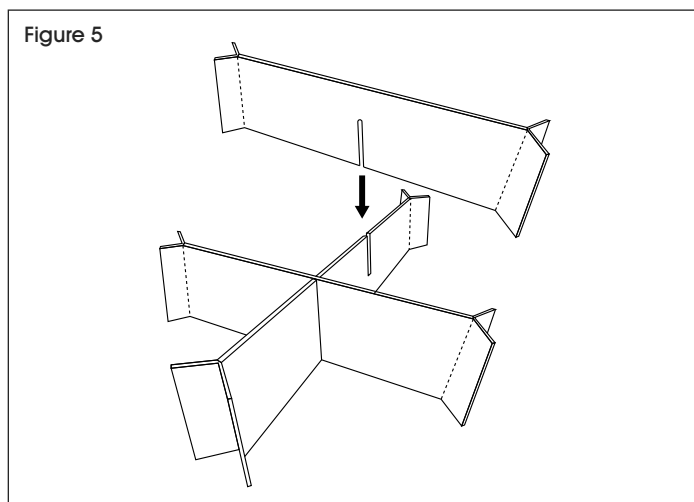

# ASSEMBLAGE DE LA BOÎTE

1. Pliez les panneaux E et F vers le haut, puis les panneaux F vers l'intérieur. (Voir Figure 6)

Figure 6

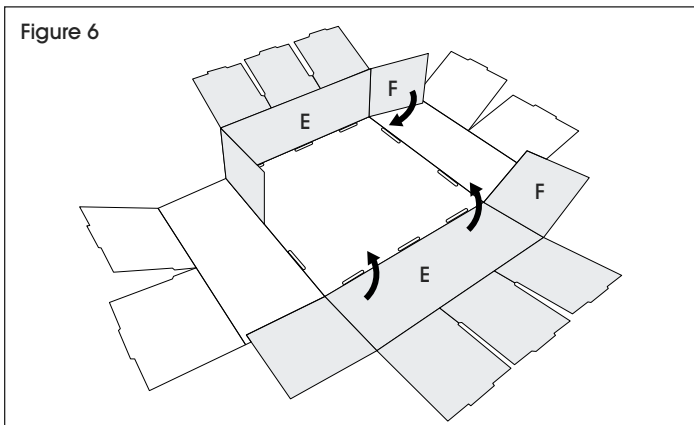

3. Pliez les panneaux H et I, et insérez-les dans les fentes au fond de la boîte. (Voir Figure 8)

Figure 8

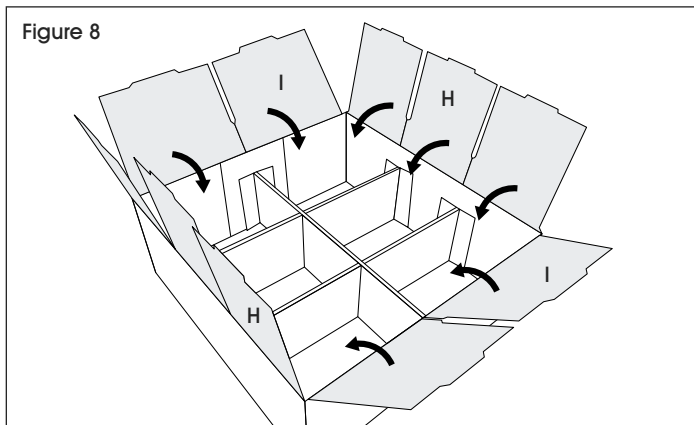

2. Pliez les panneaux G et H. Placez l'ensemble des séparateurs à l'intérieur de la boîte. (Voir Figure 7)

Figure 7

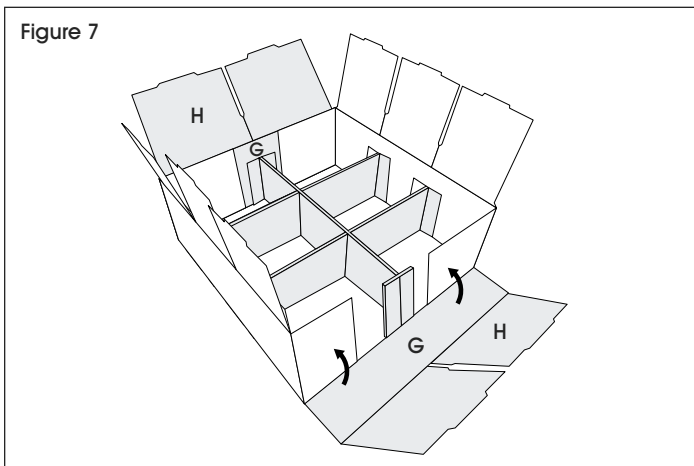

4. Placez le couvercle sur la boîte.

Assemblage complété

