

ULINE S-15180

ARCHIVAL STORAGE FILE BOX

1-800-295-5510
uline.com

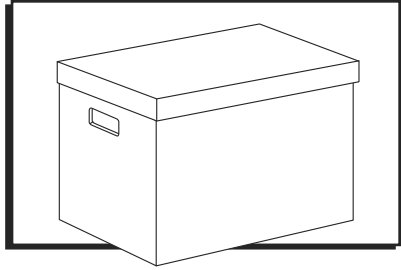

ASSEMBLY

BOX ASSEMBLY

1. Fold side A inside box so it fits snugly against inside wall of carton. Side A will extend beyond the inside wall. (See Figure 1)

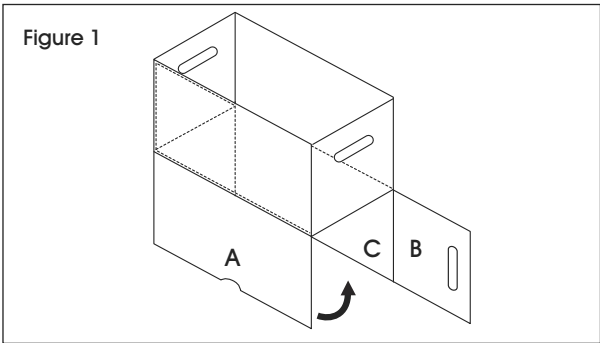

2. Break perforations on sides B and D, and fold sides inward against side C. (See Figure 2)

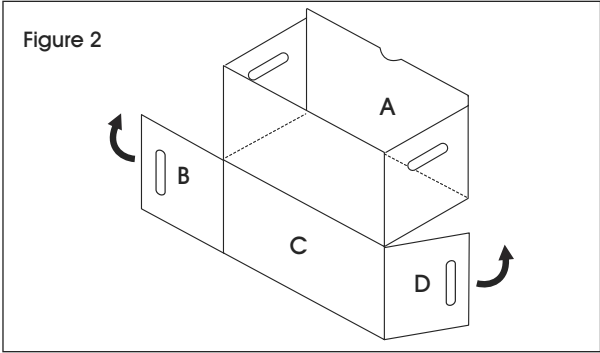

3. Fold sides B, C and D up to form bottom of carton. (See Figure 3)

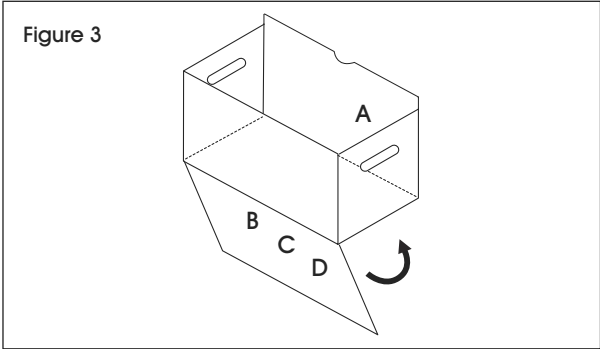

4. Place carton on flat surface. Lift sides B and D up against carton walls. (See Figure 4)

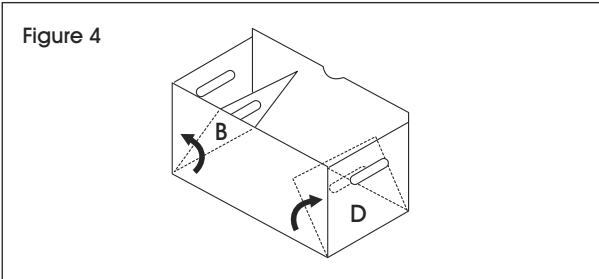

5. Push side A down against bottom of carton. (See Figure 5)

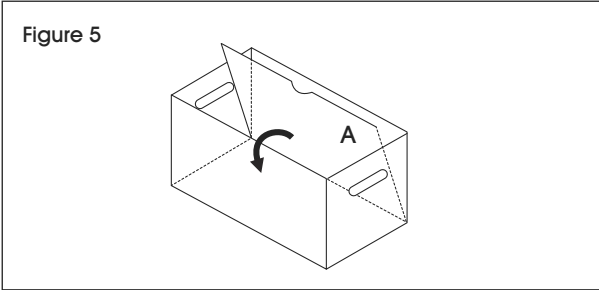

ASSEMBLY CONTINUED

LID ASSEMBLY

1. Lift side panels up and fold in small side flaps to center. (See Figure 6)

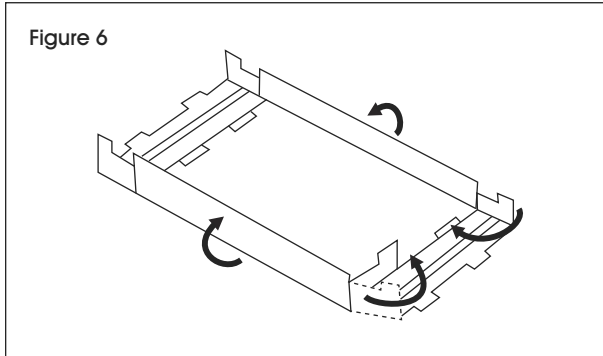

2. Fold end panel up and over flaps to lock tabs into slots. (See Figure 7)
3. Repeat step 2 on other end. (See Figure 7)

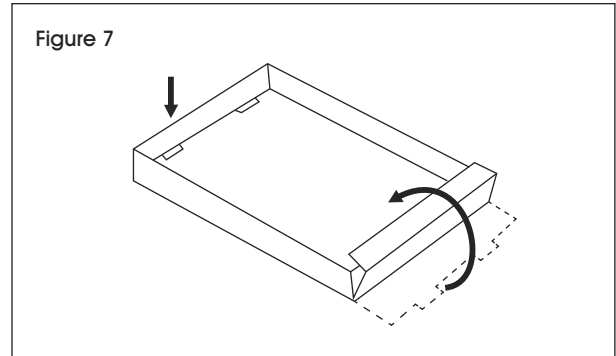

ULINE

1-800-295-5510
uline.com

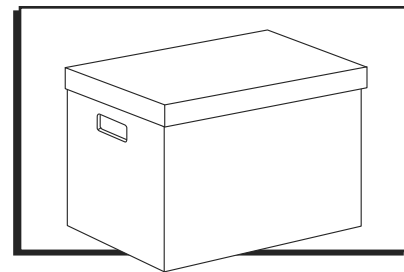
**ENSAMBLE****ENSAMBLE DE LA CAJA**

1. Doble el lateral A hacia adentro de la caja de forma que se acople bien dentro de la pared interior de la caja. El lateral A se extenderá más allá de la pared interior. (Vea Diagrama 1)

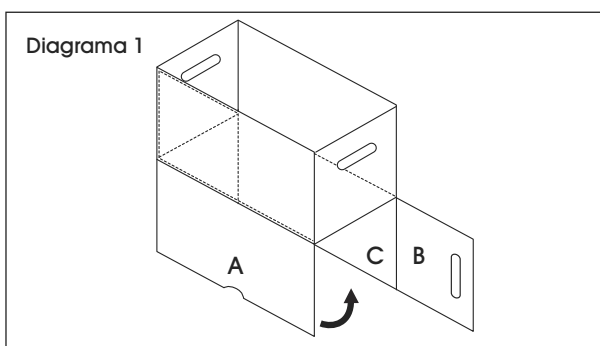

2. Rompa las perforaciones de los laterales B y D y doble los laterales de forma que queden planos contra C. (Vea Diagrama 2)

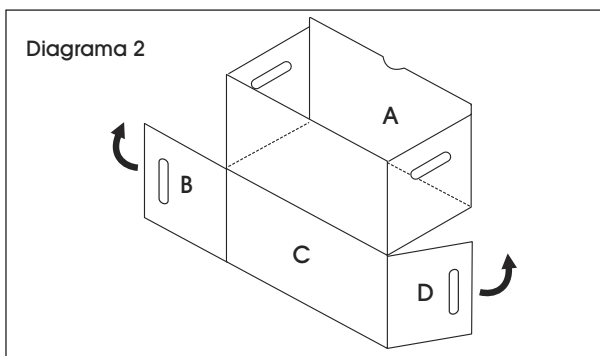

3. Doble los laterales B, C y D hacia arriba para formar la base de la caja. (Vea Diagrama 3)

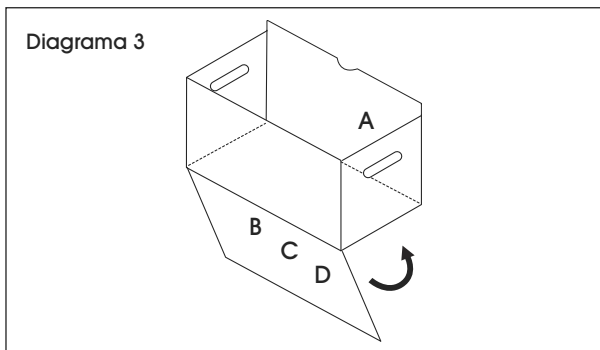

4. Coloque la caja sobre una superficie plana. Levante los laterales B y D contra las paredes de la caja. (Vea Diagrama 4)

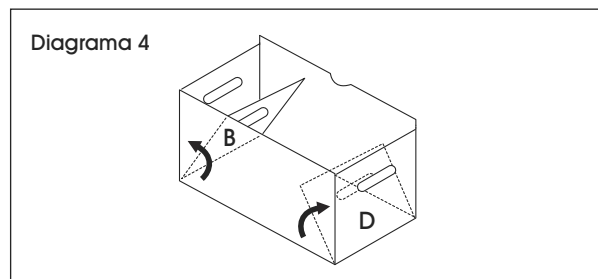

5. Empuje el lateral A hacia abajo, hacia el fondo de la caja. (Vea Diagrama 5)

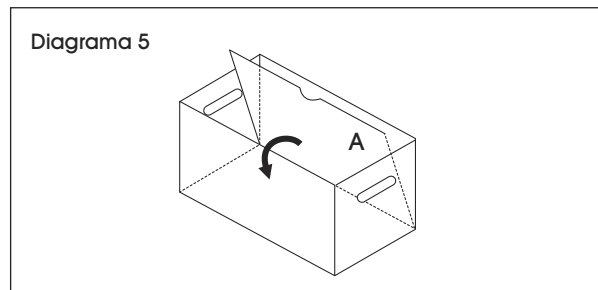

ENSAMBLE DE LA TAPA

1. Levante los paneles laterales e integre los paneles pequeños hacia el centro. (Vea Diagrama 6)

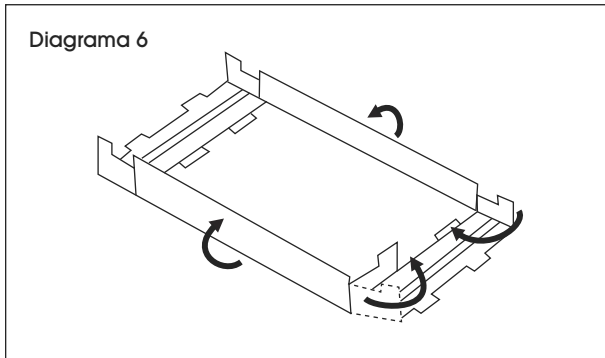

2. Doble el panel del extremo hacia arriba y por encima para asegurar las pestañas dentro de las ranuras. (Vea Diagrama 7)
3. Repita el paso 2 con el otro extremo. (Vea Diagrama 7)

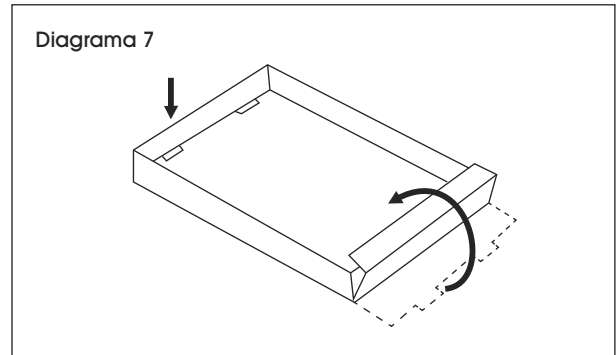

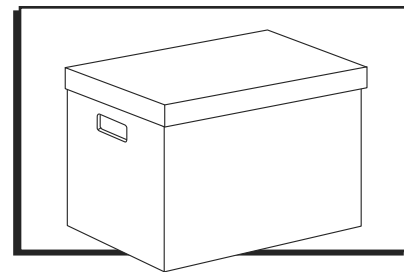
**BOÎTE DE RANGEMENT
DE DOSSIERS D'ARCHIVAGE****ASSEMBLAGE****ASSEMBLAGE DE LA BOÎTE**

1. Pliez le côté A vers l'intérieur de la boîte de façon à ce qu'il se pose parfaitement contre la paroi intérieure de la boîte. Le côté A se prolongera au-delà de la paroi intérieure. (Voir Figure 1)

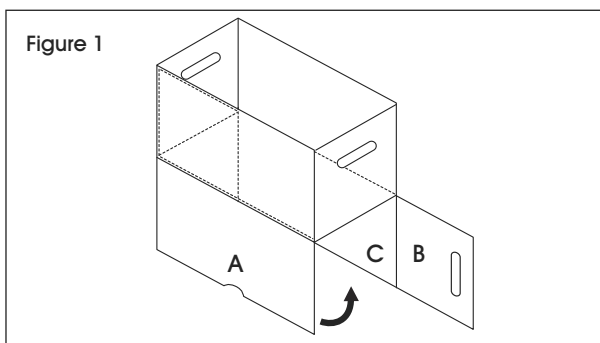

2. Transpercez les lignes perforées des côtés B et D, puis pliez les côtés à plat contre le côté C. (Voir Figure 2)

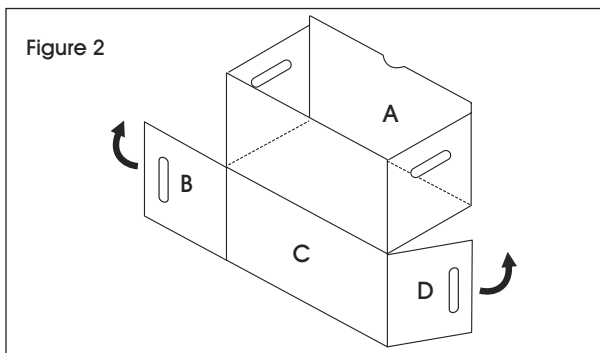

3. Pliez les côtés B, C et D pour former le fond de la boîte. (Voir Figure 3)

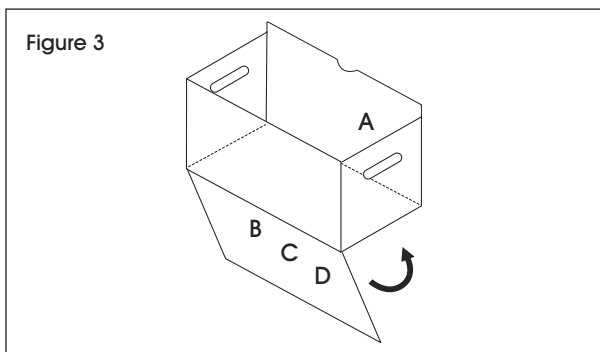

4. Placez la boîte sur une surface plane. Soulevez les côtés B et D contre les parois de la boîte. (Voir Figure 4)

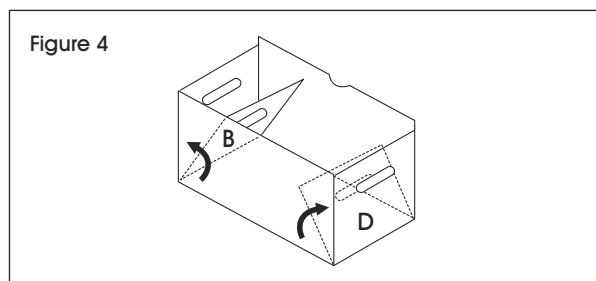

5. Poussez le côté A vers le fond de la boîte. (Voir Figure 5)

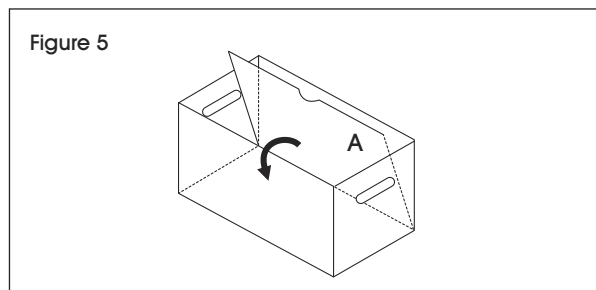

ASSEMBLAGE DU COUVERCLE

1. Soulevez les panneaux latéraux vers le haut et pliez les petits panneaux vers le centre. (Voir Figure 6)

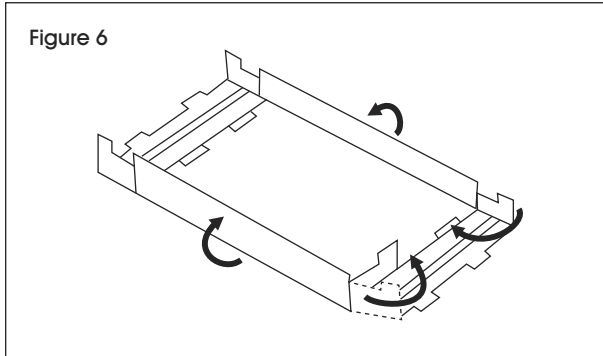

2. Pliez le panneau d'extrémité vers le haut, puis par-dessus les rabats afin de fixer les languettes dans les fentes. (Voir Figure 7)
3. Répétez l'étape 2 de l'autre côté. (Voir Figure 7)

