

ULINE S-16502, S-16503
JUMBO CARRYING CASES

1-800-295-5510
uline.com

Para Español, vea páginas 3-4.
Pour le français, consulter les pages 5-6.

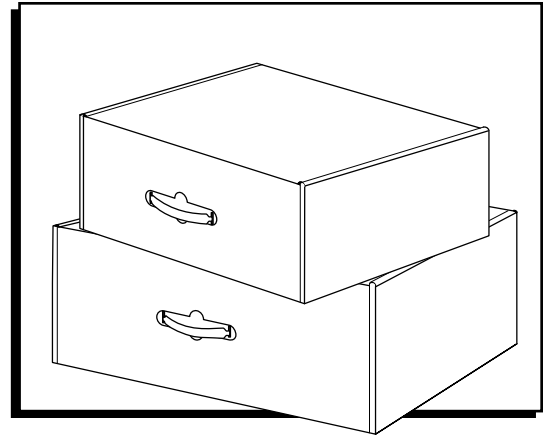

ASSEMBLY

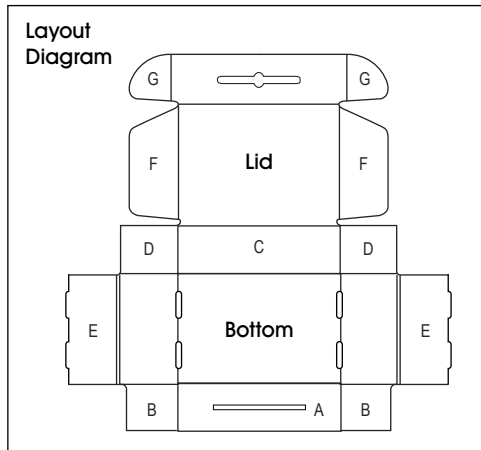

2. Fold in flaps B and D. (See Figure 2)

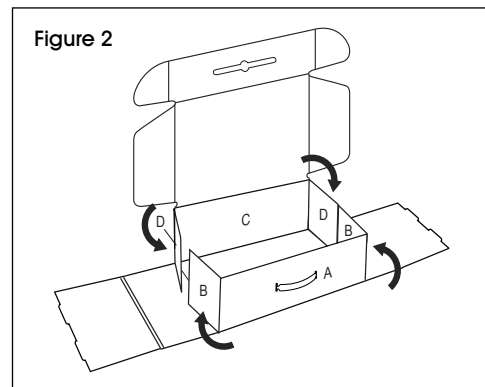

1. Fold panels A and C straight up so they are perpendicular to the bottom. (See Figure 1)

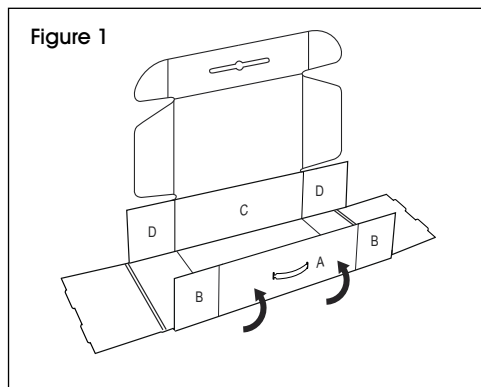

ASSEMBLY CONTINUED

3. To form sides of box, fold ends E up and over flaps B and D, tucking into slots at the bottom. (See Figures 3-4)

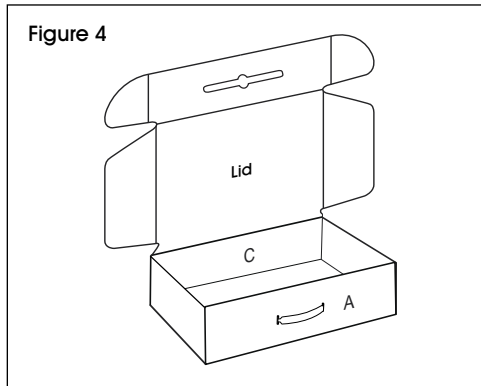
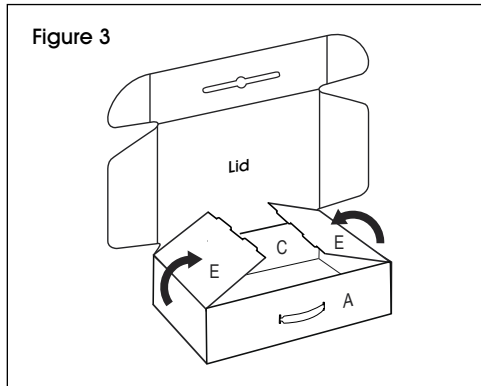

4. Fold flaps F inward so they slide inside the mailer when closing. (See Figures 5-6)

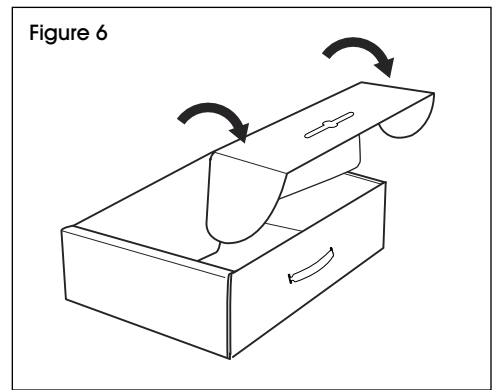
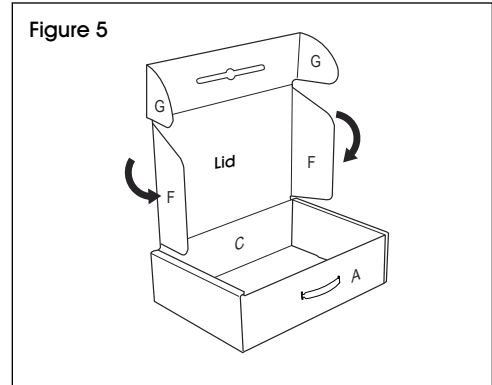

5. Fold front lock tabs G inward and slide into the slots in the front of the mailer to secure. Pull handle through opening. (See Figure 7)

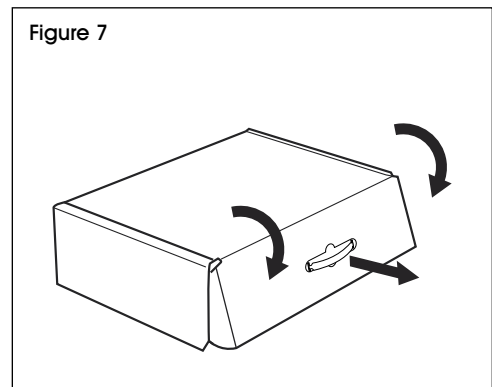

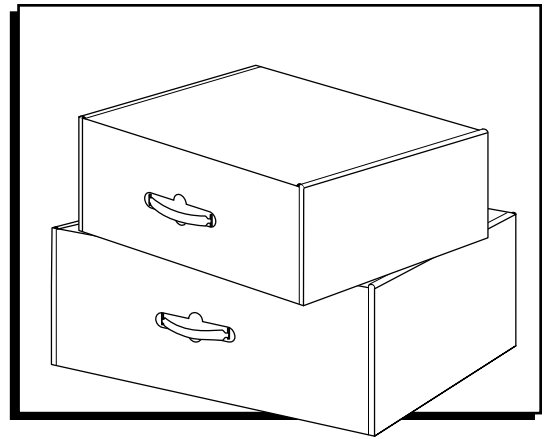

ENSAMBLE

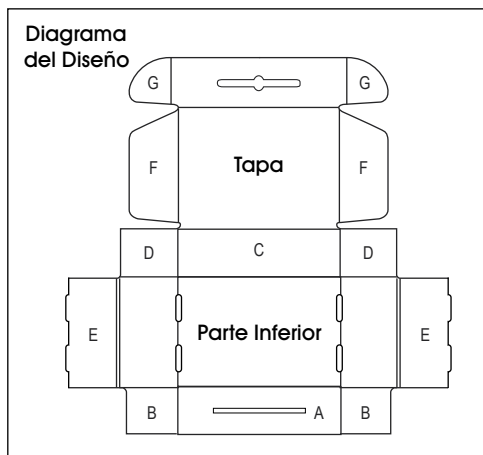

1. Doble los paneles A y C hacia arriba de manera que queden perpendiculares a la parte inferior. (Vea Diagrama 1)

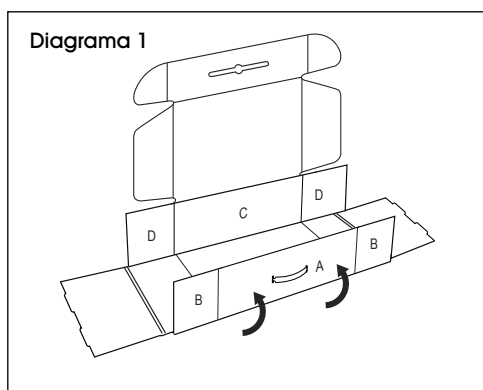

2. Doble hacia adentro las solapas B y D. (Vea Diagrama 2)

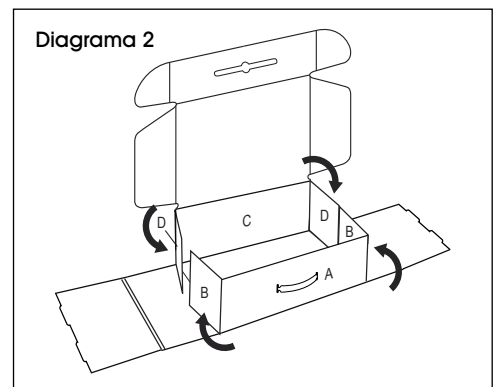

CONTINUACIÓN DE ENSAMBLE

3. Para formar los lados de la caja, doble los extremos E hacia arriba y pase sobre las solapas B y D, ajustando dentro de las ranuras en la parte inferior. (Vea Diagramas 3-4)

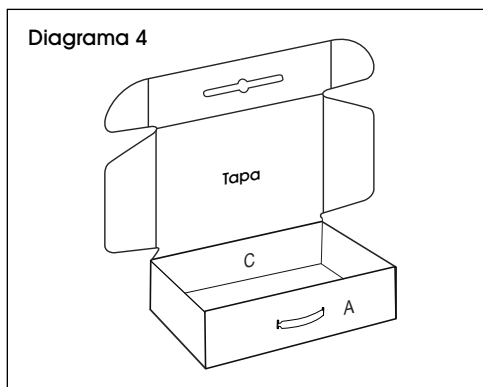
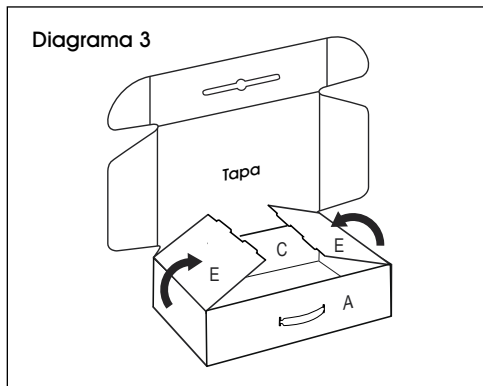

4. Doble las solapas F hacia el interior de manera que se deslicen dentro de la caja cuando la cierre. (Vea Diagramas 5-6)

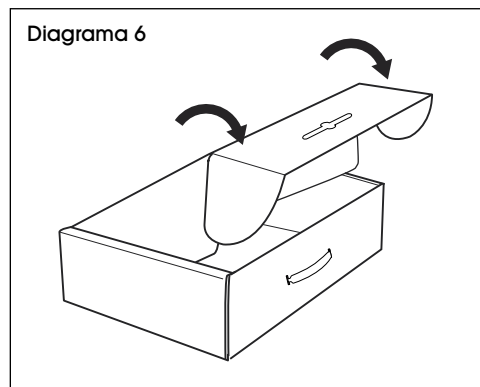
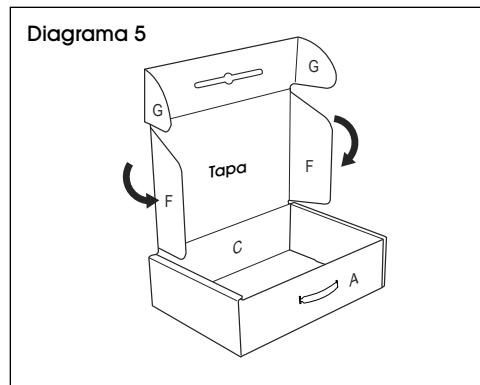

5. Doble las pestañas frontales G hacia el interior y deslícelas dentro de las ranuras en el frente de la caja para asegurarla. Jale el asa a través de la abertura. (Vea Diagrama 7)

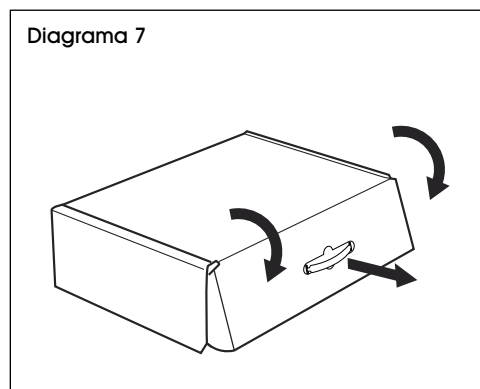

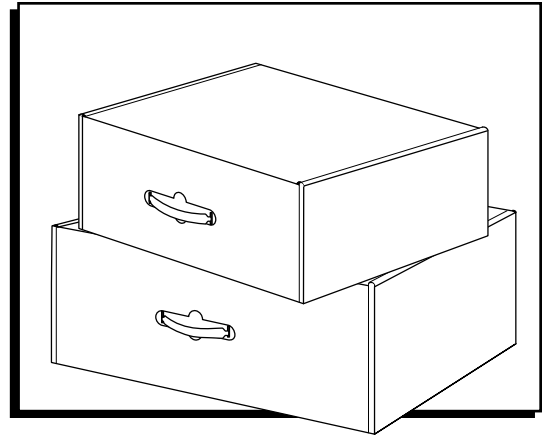

ASSEMBLAGE

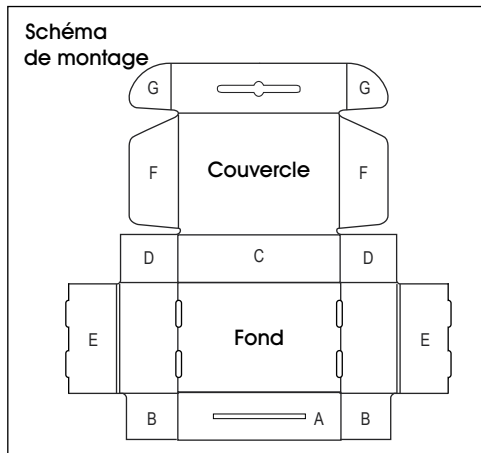

2. Pliez les rabats B et D vers l'intérieur. (Voir Figure 2)

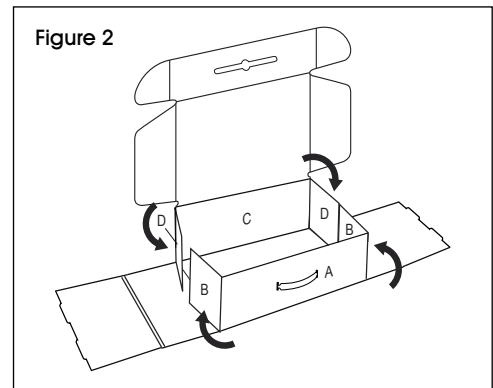

1. Pliez les rabats A et C vers le haut afin qu'ils soient perpendiculaires avec le fond de la boîte. (Voir Figure 1)

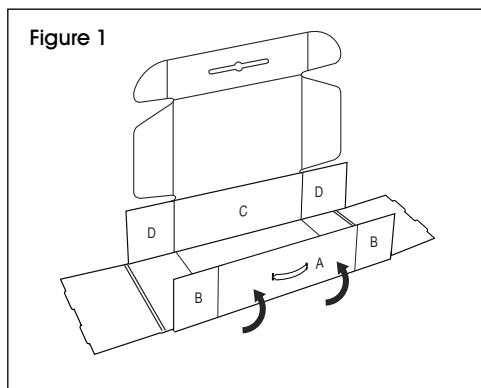

ASSEMBLAGE SUITE

3. Pour former les côtés de la boîte, pliez les rabats E vers le haut et par dessus les rabats B et D. Insérez-les ensuite dans les fentes sur le fond. (Voir Figures 3-4)

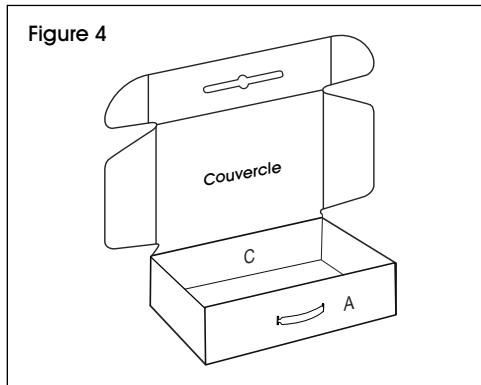
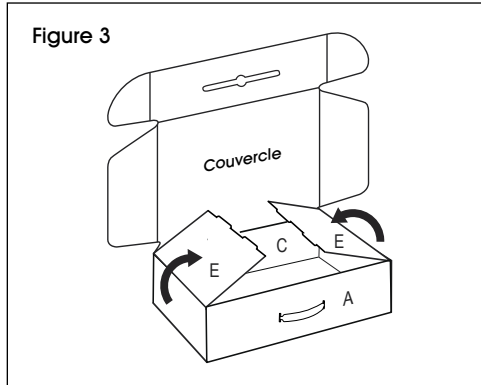

4. Pliez les rabats F vers l'intérieur de manière à ce qu'ils s'insèrent dans la boîte pendant sa fermeture. (Voir Figures 5-6)

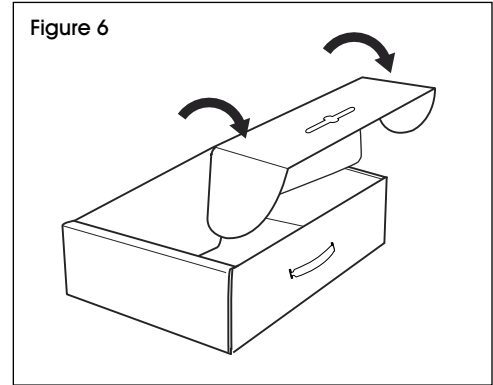
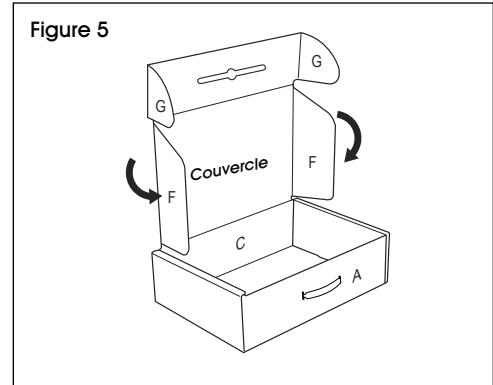

5. Pliez les languettes de fermeture G vers l'intérieur et insérez-les dans les fentes à l'avant de la boîte pour sécuriser la fermeture. Faites sortir la poignée vers l'ouverture. (Voir Figure 7)

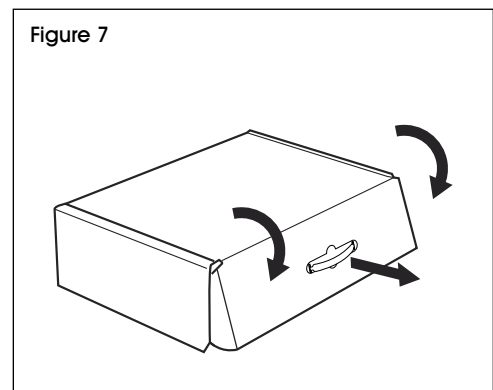

ULINE

1 800 295-5510
uline.ca