

INSTRUCTIONS

1. Tear off top of bag along perforation. (See Figure 1)

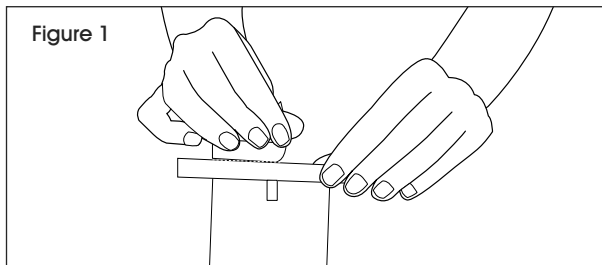

2. Use pull tabs on each side to open bag. (See Figure 2)

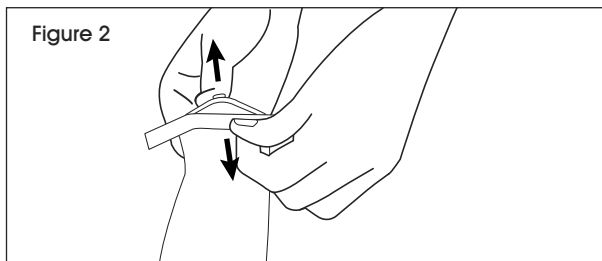

3. Put sample in bag. Leave enough space at top for closing and mixing. Pull the wire ends to close the bag. (See Figure 3)

 **NOTE:** If labeling bag with sample information, label before filling.

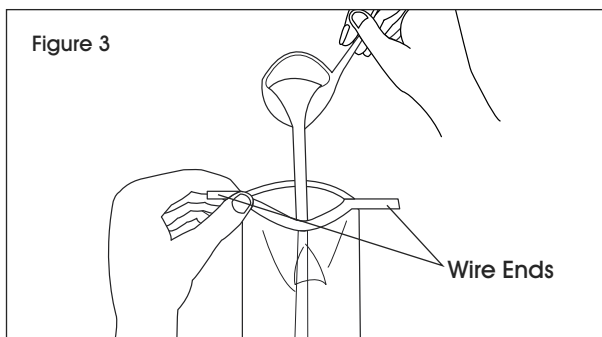

4. Holding the bag by the wire ends, whirl the bag three complete revolutions to form a leakproof seal. (See Figure 4)

 **NOTE:** Whirling the bag will form the tightest seal. Larger bags can be closed by folding the tab over as tightly as possible.

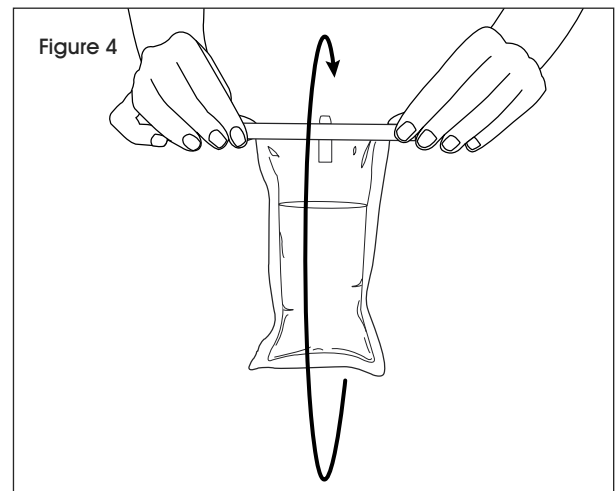

5. Bend the wire ends over the bag to secure the seal. (See Figure 5)

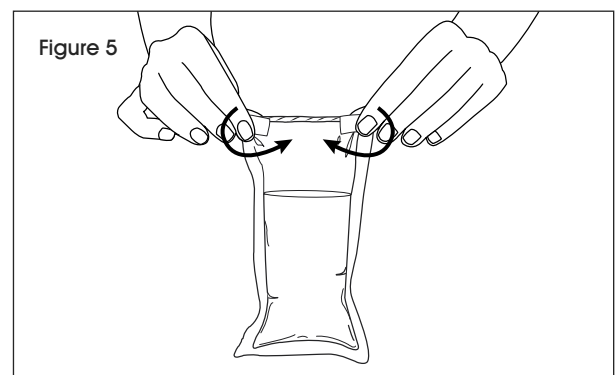

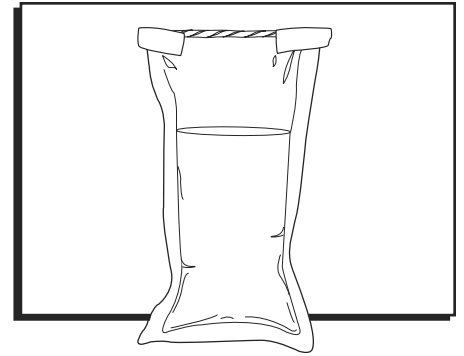

INSTRUCCIONES

1. Rasgue la parte superior de la bolsa por la línea punteada. (Vea Diagrama 1)

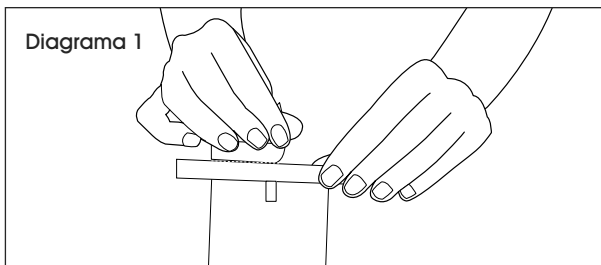

2. Jale las pestañas ubicadas a cada lado para abrir la bolsa. (Vea Diagrama 2)

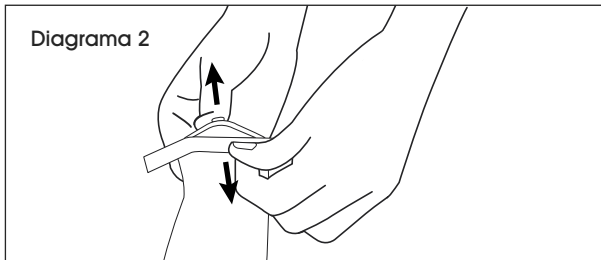

3. Meta la muestra en la bolsa. Deje suficiente espacio en la parte superior para cerrar y mezclar. Jale los extremos de alambre para cerrar la bolsa. (Vea Diagrama 3)

 **NOTA:** Si desea etiquetar la bolsa con información sobre la muestra, etiquétela antes de llenar.

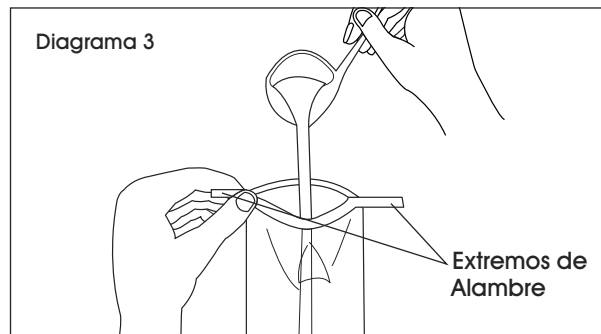

4. Sostenga la bolsa por los extremos de alambre, haga tres dobleces a la bolsa para formar un sello antigoteo. (Vea Diagrama 4)

 **NOTA:** Hacer tres dobleces a la bolsa es la mejor manera de formar un sello antigoteo. Las bolsas más grandes pueden cerrarse doblando la pestaña una y otra vez lo más posible.

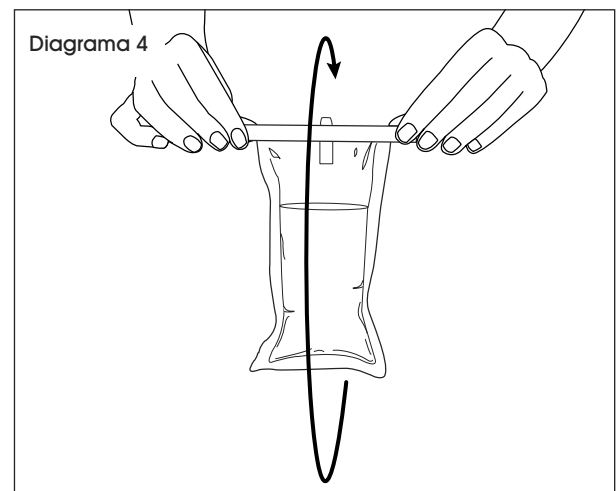

5. Doble los extremos de alambre hacia la bolsa para fijar el sello. (Vea Diagrama 5)

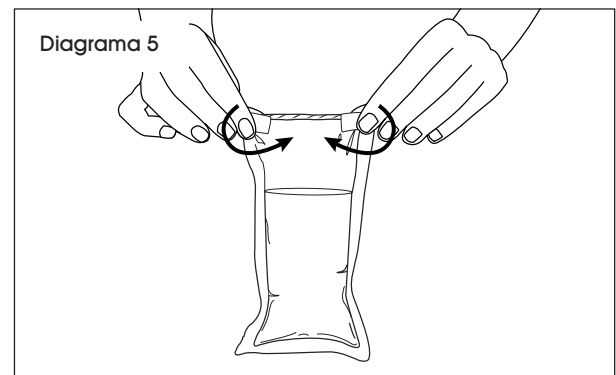

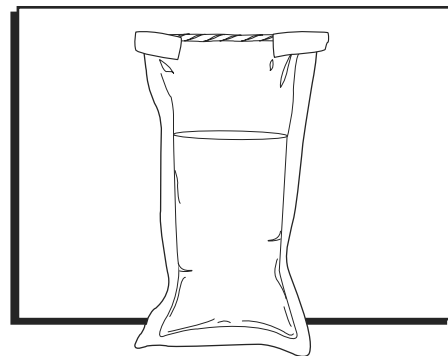

INSTRUCTIONS

1. Déchirez le haut du sac le long de la ligne perforée. (Voir Figure 1)

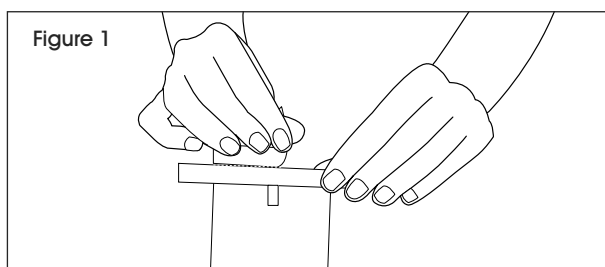

2. Utilisez les rabats de chaque côté pour ouvrir le sac. (Voir Figure 2)

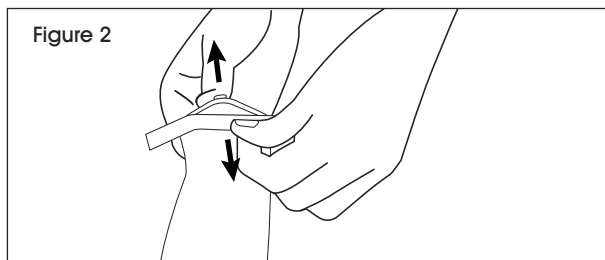

3. Placez l'échantillon dans le sac. Laissez suffisamment d'espace pour pouvoir fermer et mélanger. Tirez les attaches en fil de métal pour fermer le sac. (Voir Figure 3)

 **REMARQUE :** Si vous devez étiqueter le sac pour y inscrire des renseignements sur l'échantillon, faites-le avant de le remplir.

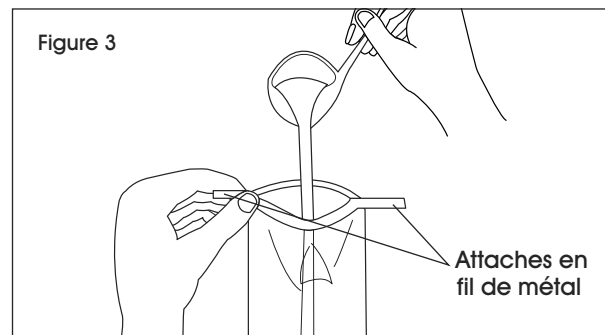

4. Tenez le sac par les attaches en fil de métal, puis faites-le tourner à trois reprises sur lui-même pour former un joint étanche. (Voir Figure 4)

 **REMARQUE :** Tournoyer le sac permettra au joint d'être plus serré. Les sacs plus larges peuvent être fermés en repliant les rabats sur eux-mêmes le plus fermement possible.

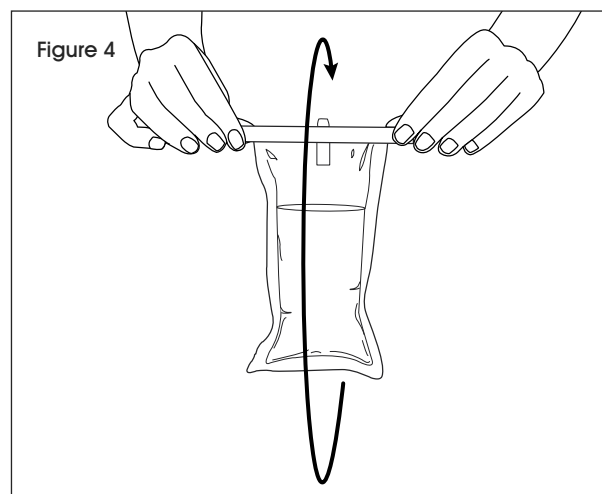

5. Repliez les attaches en fil de métal par-dessus le sac pour fixer le joint. (Voir Figure 5)

