

ULINE S-16671 RETENTION BOX

1-800-295-5510
uline.com

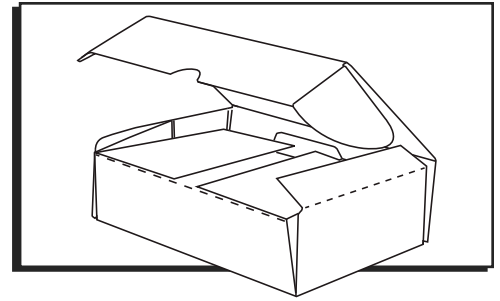

ASSEMBLY

1. Lift tension flaps (A) and slide product under film. (See Figure 1)

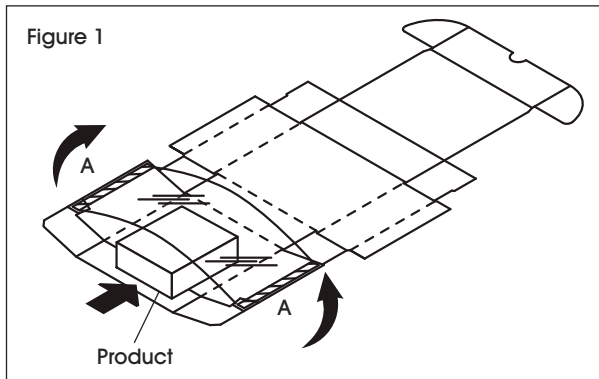

4. Fold smaller flaps toward the middle of the box. (See Figure 4)

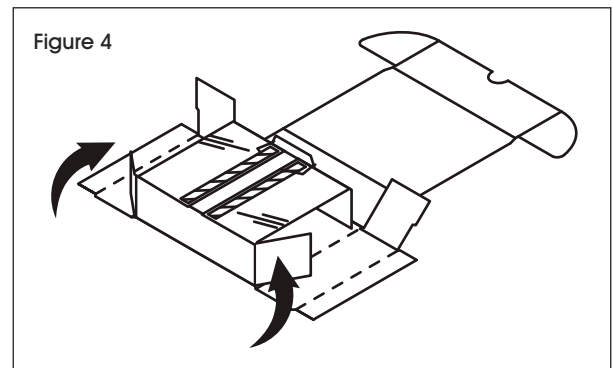

2. Fold both tension flaps (A) with equal force down and under panel (C). (See Figure 2)

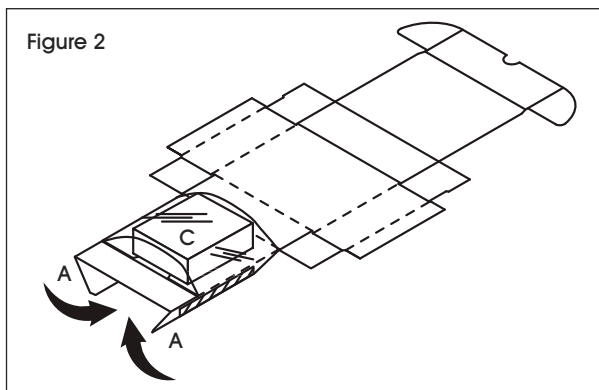

5. Fold side panels (E) and rails (F) over the top. Fold remaining flaps toward the middle. (See Figure 5)

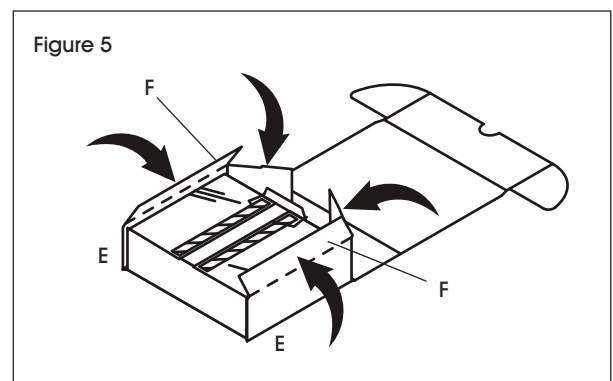

3. Lock the tab in place by folding side panel (B) up 90°. Roll panel (C) over panel (D). (See Figure 3)

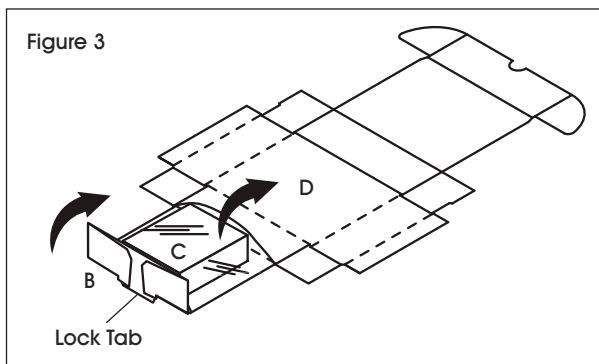

6. Fold panel (G) over the top and tuck flaps into side slots. (See Figure 6)

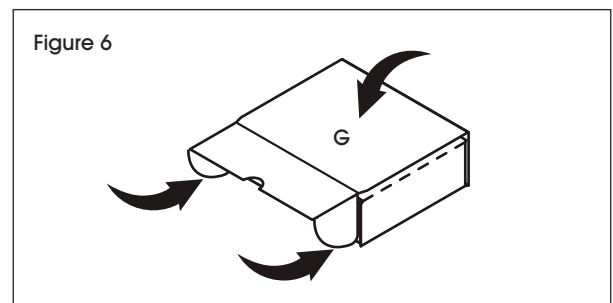

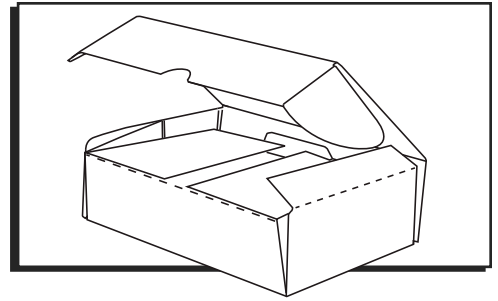
**CAJA DE
RETENCIÓN****ENSAMBLE**

1. Levante las solapas de tensión (A) y deslice el producto por debajo de la película. (Vea Diagrama 1)

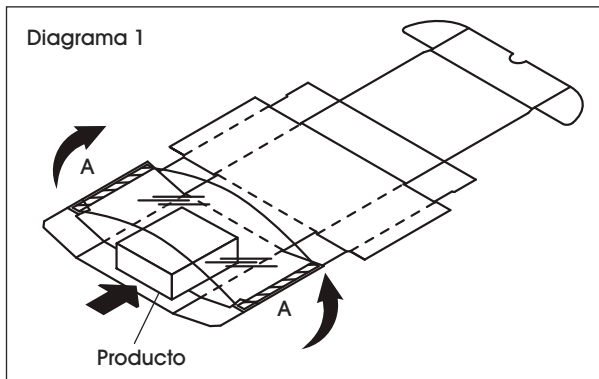

2. Doble ambas solapas de tensión (A) debajo del panel (C) con igual fuerza. (Vea Diagrama 2)

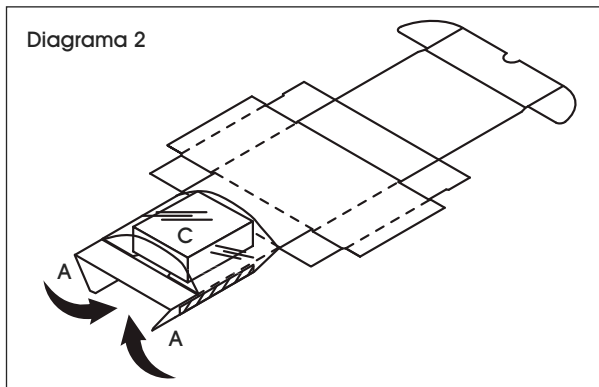

3. Sujete la solapa en su lugar doblando el panel lateral (B) a 90°. Doble el panel (C) sobre el panel (D). (Vea Diagrama 3)

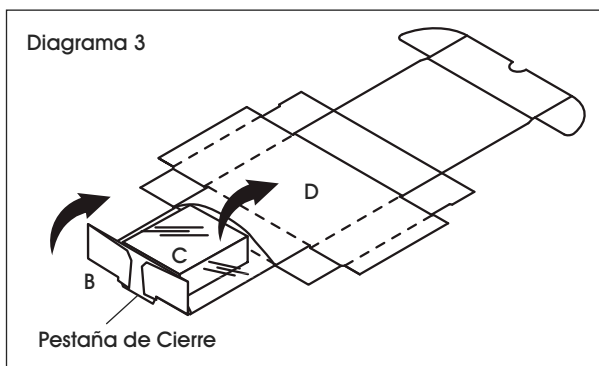

4. Doble las solapas más pequeñas hacia el centro de la caja. (Vea Diagrama 4)

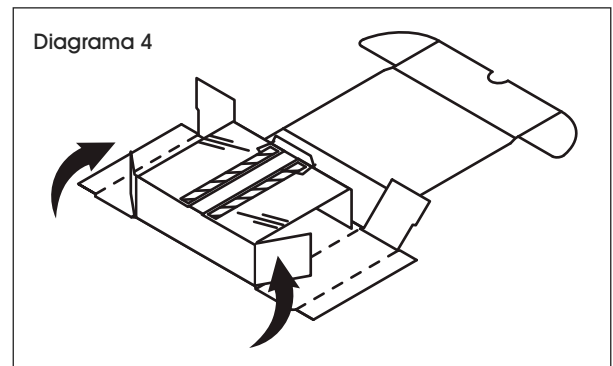

5. Doble los paneles laterales (E) y los rieles (F) por encima de la parte superior. Doble el resto de las solapas hacia el centro. (Vea Diagrama 5)

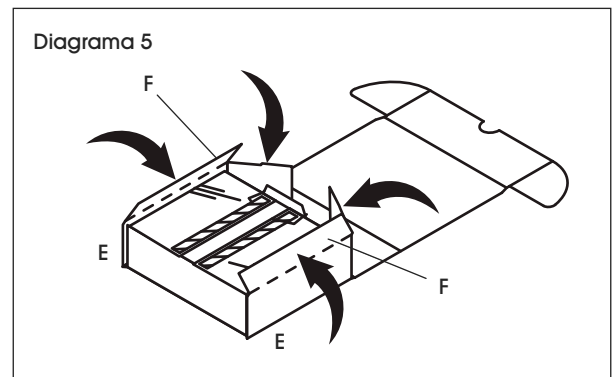

6. Doble el panel (G) por encima e introduzca las solapas en las ranuras laterales. (Vea Diagrama 6)

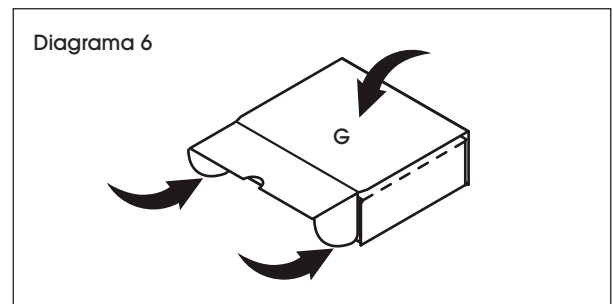

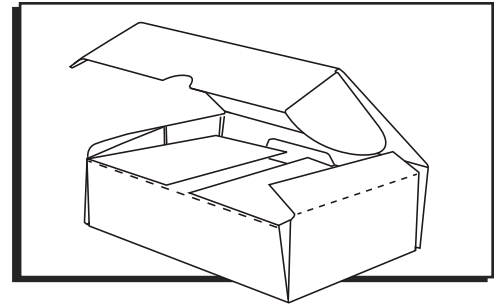
**BOÎTE DE
RÉTENTION****ASSEMBLAGE**

1. Soulevez les rabats de tension (A) et glissez l'article sous la pellicule. (Voir Figure 1)

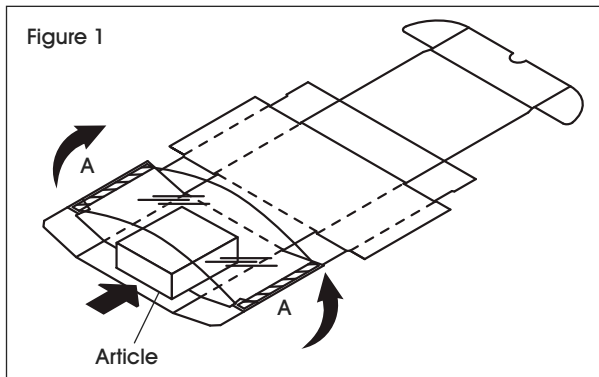

2. Repliez les deux rabats de tension (A) avec la même force vers le bas et sous le panneau (C). (Voir Figure 2)

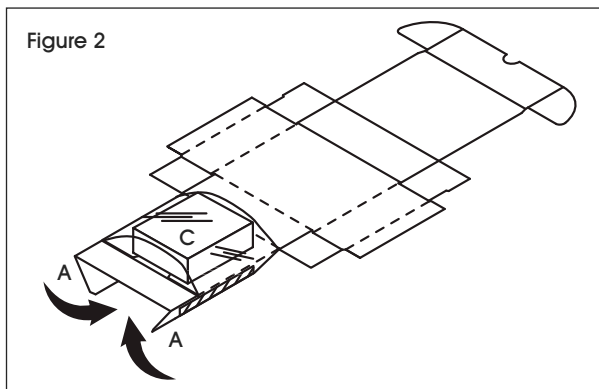

3. Fixez la languette en place en pliant le panneau latéral (B) à 90°. Roulez le panneau (C) par-dessus le panneau (D). (Voir Figure 3)

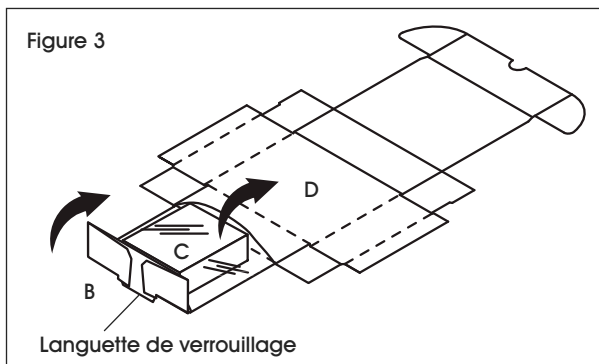

4. Pliez les petits rabats vers le milieu de la boîte. (Voir Figure 4)

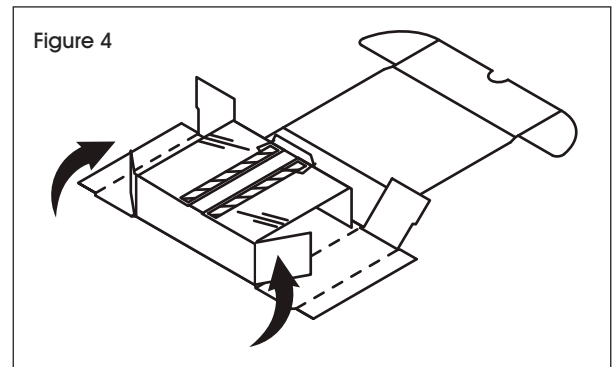

5. Pliez les panneaux latéraux (E) et les longerons (F) vers le haut. Pliez les autres petits rabats vers le milieu. (Voir Figure 5)

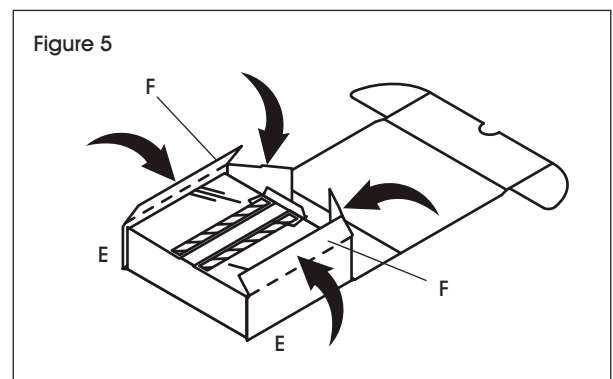

6. Repliez le panneau (G) sur le dessus de la boîte et rentrez les rabats dans les fentes latérales. (Voir Figure 6)

