

ULINE S-16673 RETENTION BOX KIT

1-800-295-5510
uline.com

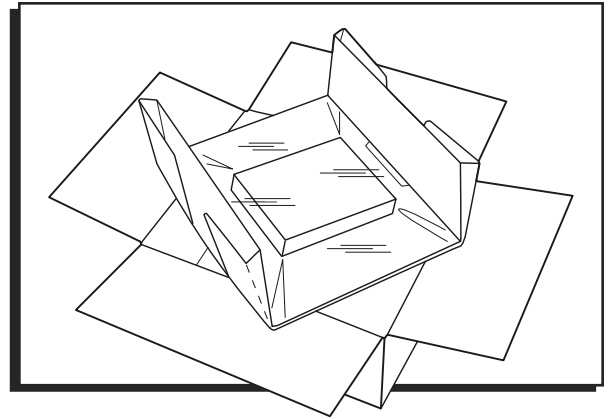

ASSEMBLY

1. Pre-fold tension flaps to release film. Place product under film. (See Figure 1)

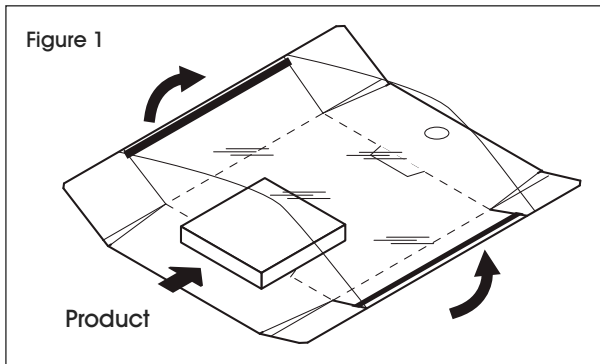

2. Fold both tension flaps with equal force down and under base. (See Figure 2)

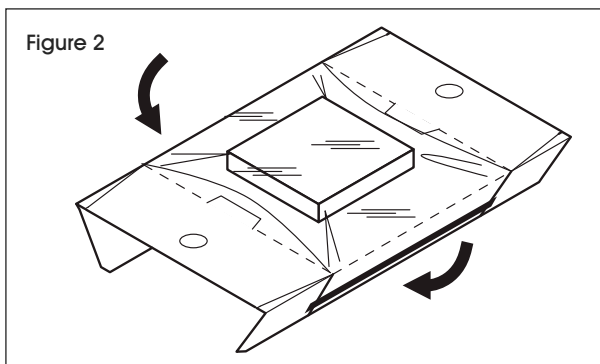

3. Fold both outer panels upright. Ensure pop-down tabs are folded down. (See Figure 3)

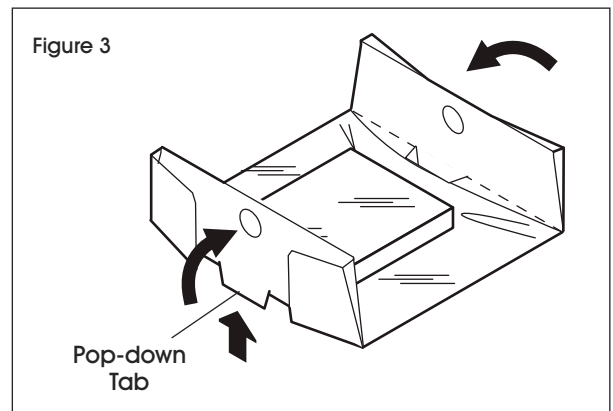

4. Hold both outer panels upright and insert frame into carton. (See Figure 4)

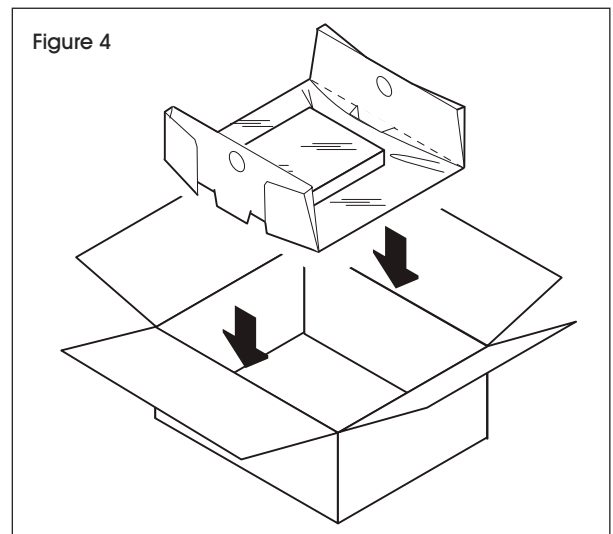

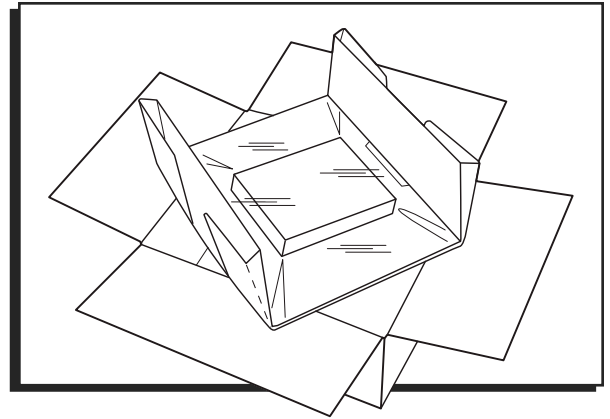
**ENSAMBLE**

1. Doble previamente las solapas de tensión para liberar la película. Coloque el producto debajo de la película. (Vea Diagrama 1)

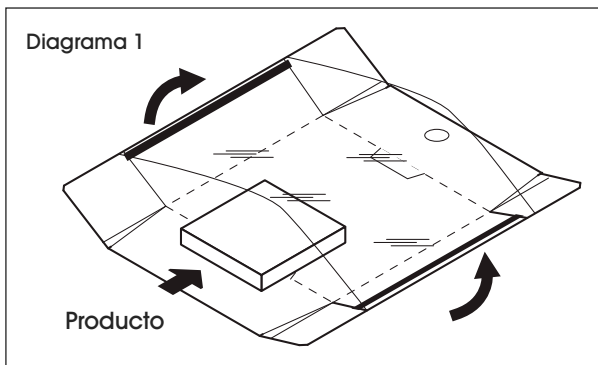

2. Doble ambas solapas con fuerza hacia abajo y por debajo de la base. (Vea Diagrama 2)

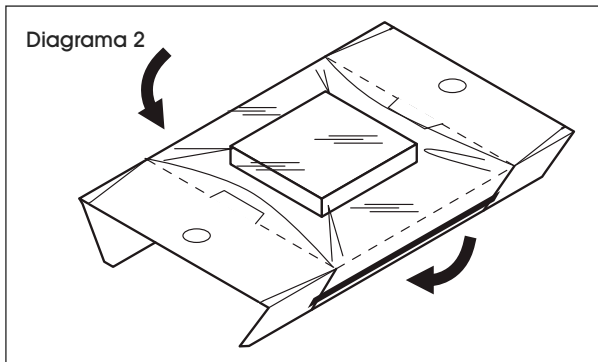

3. Doble ambos paneles interiores para colocarlos en posición vertical. Asegúrese de que las pestañas sobresalientes estén dobladas hacia abajo. (Vea Diagrama 3)

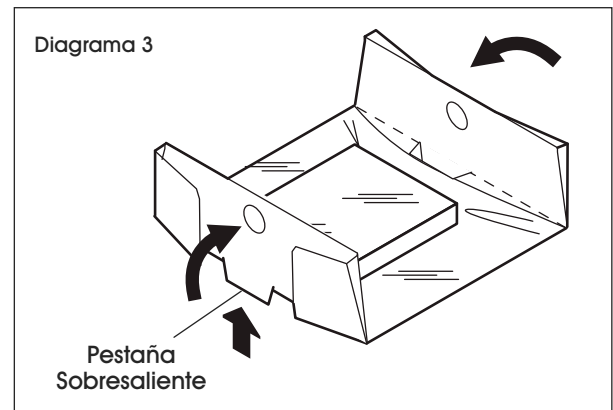

4. Sostenga ambos paneles exteriores para colocarlos en posición vertical e inserte el marco en la caja. (Vea Diagrama 4)

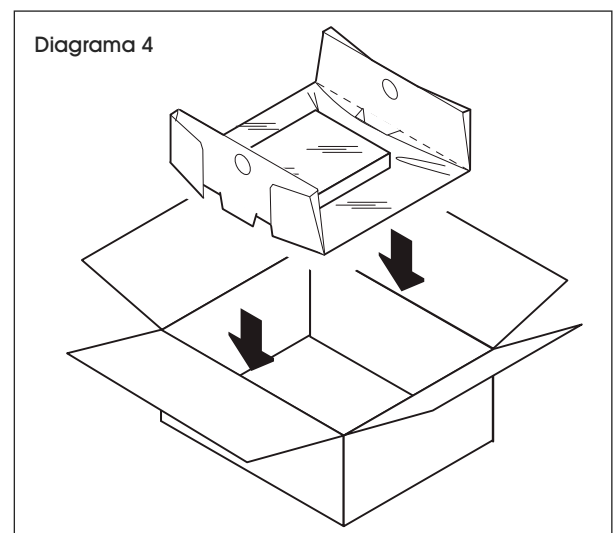

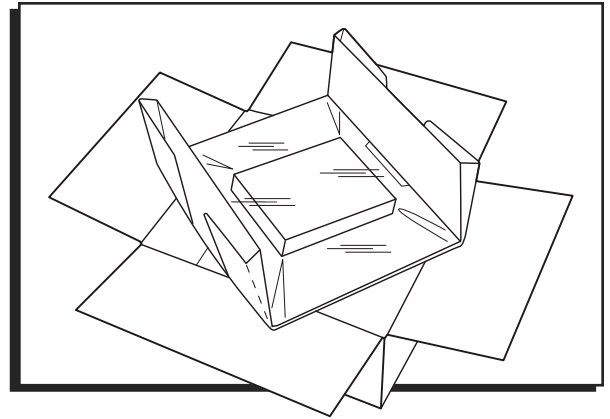
**ASSEMBLAGE**

1. Pliez les rabats de tension pour libérer la pellicule. Placez l'article sous la pellicule. (Voir Figure 1)

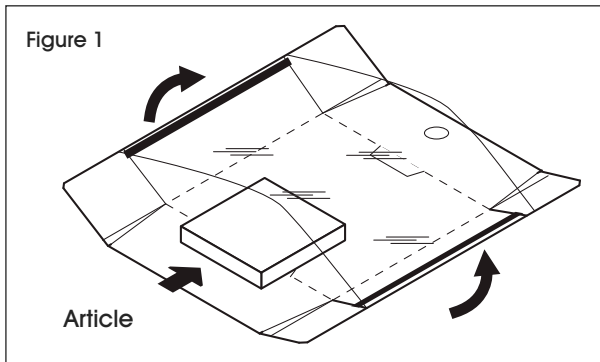

2. En exerçant une force égale, pliez les deux rabats de tension vers le bas, puis en dessous de la base. (Voir Figure 2)

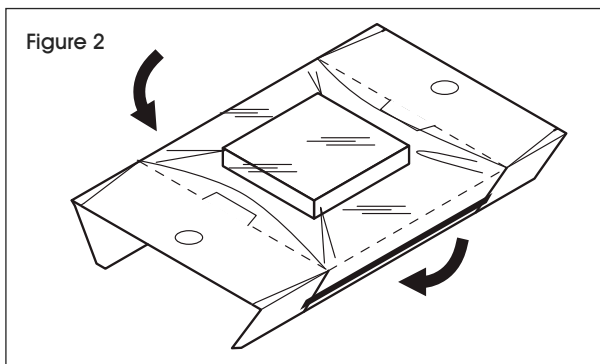

3. Pliez les deux panneaux extérieurs en position verticale. Assurez-vous que les languettes pointent vers le bas. (Voir Figure 3)

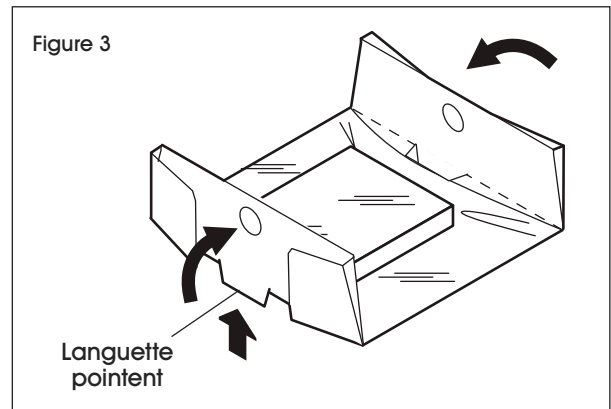

4. Tenez les deux panneaux extérieurs en position verticale et insérez le cadre dans la boîte (Voir Figure 4)

