

**ULINE** S-16675  
**RETENTION BOX KIT**

1-800-295-5510  
uline.com

Para Español, vea página 2.  
Pour le français, consulter la page 3.

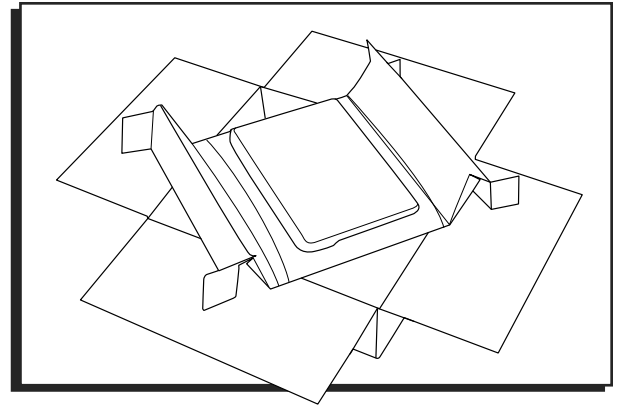

**ASSEMBLY**

1. Pre-fold tension flaps to release film. Place product under film. (See Figure 1)

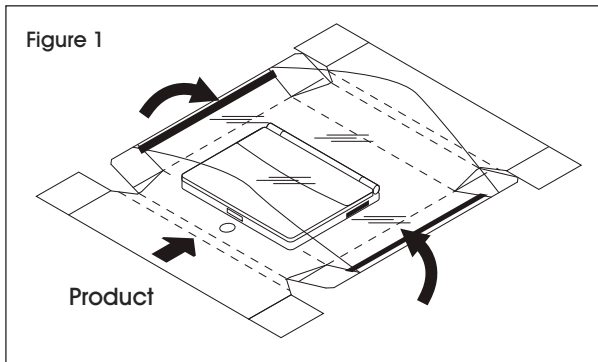

2. Fold both tension flaps with equal force down and under base. (See Figure 2)

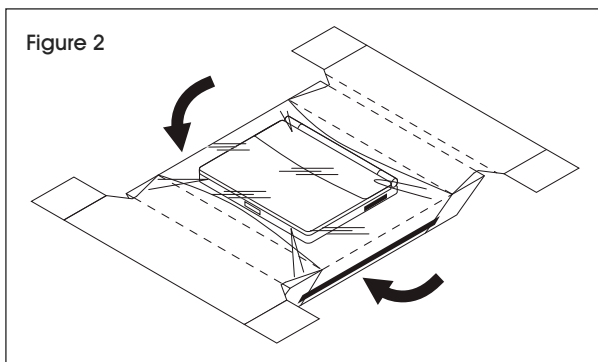

3. Fold both inner panels upright. (See Figure 3)

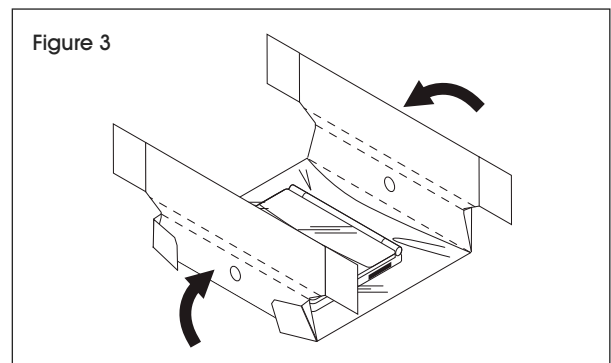

4. Fold down outer panels and dog ear panels. Hold together while inserting into carton. (See Figure 4)

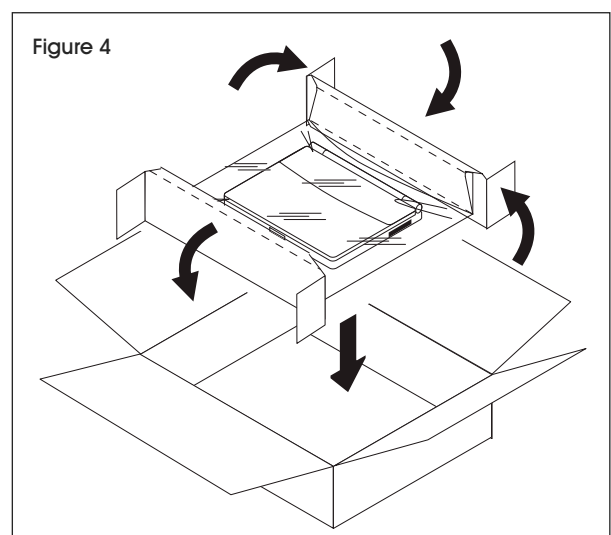

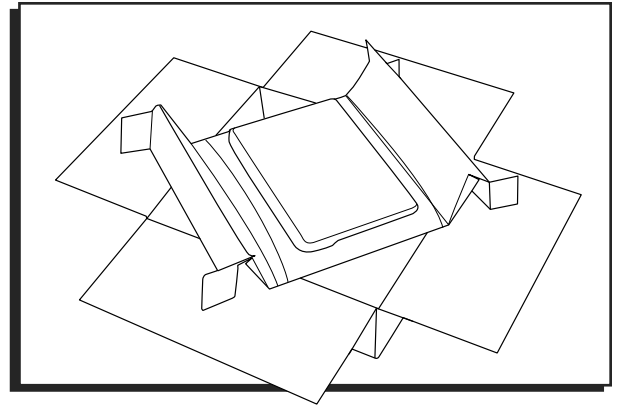
**ENSAMBLE**

1. Doble previamente las solapas de tensión para liberar la película. Coloque el producto debajo de la película. (Vea Diagrama 1)

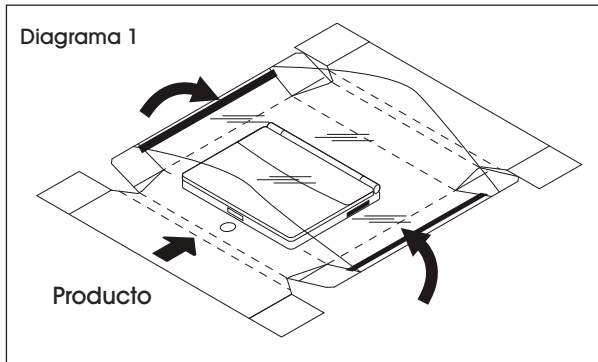

2. Doble ambas solapas con fuerza hacia abajo y por debajo de la base. (Vea Diagrama 2)

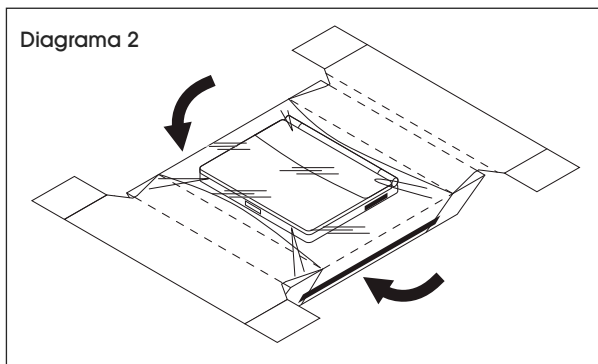

3. Doble ambos paneles interiores para colocarlos en posición vertical. (Vea Diagrama 3)

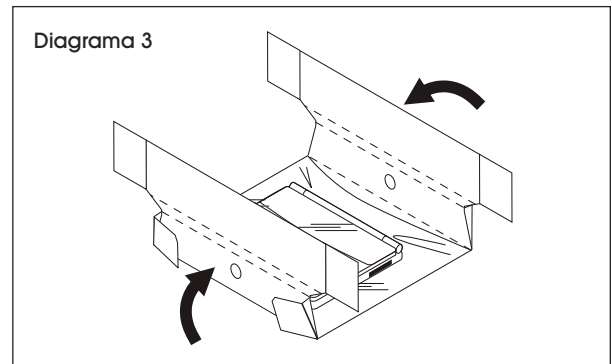

4. Doble los paneles exteriores hacia abajo y los paneles en forma de oreja de perro. Sosténgalos juntos mientras los inserta en la caja. (Vea Diagrama 4)

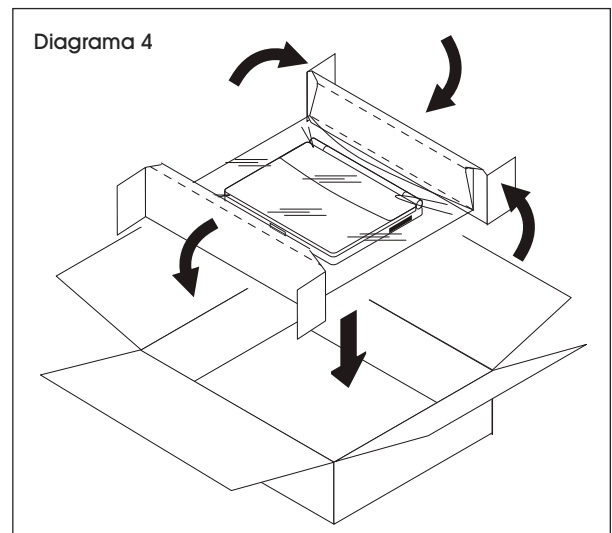

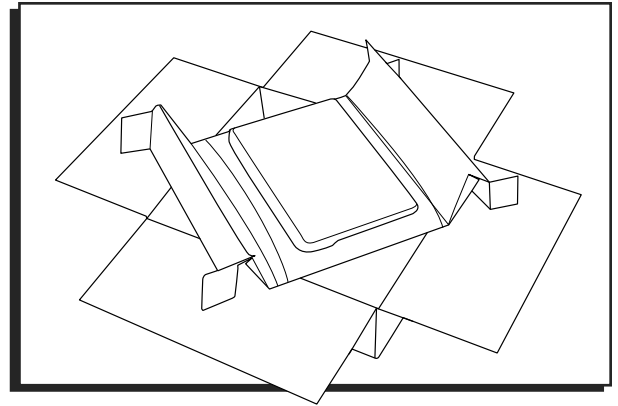
**ASSEMBLAGE**

1. Pliez les rabats de tension pour libérer la pellicule. Placez l'article sous la pellicule. (Voir Figure 1)

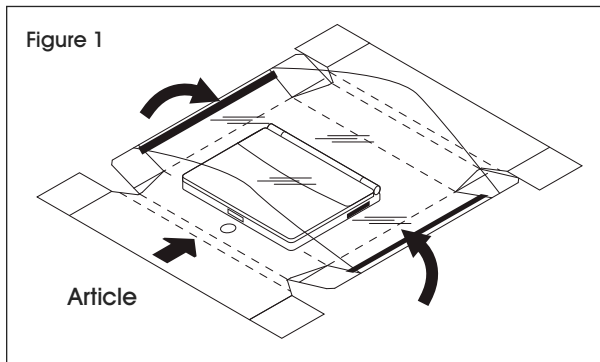

2. En exerçant une force égale, pliez les deux rabats de tension vers le bas, puis en dessous de la base. (Voir Figure 2)

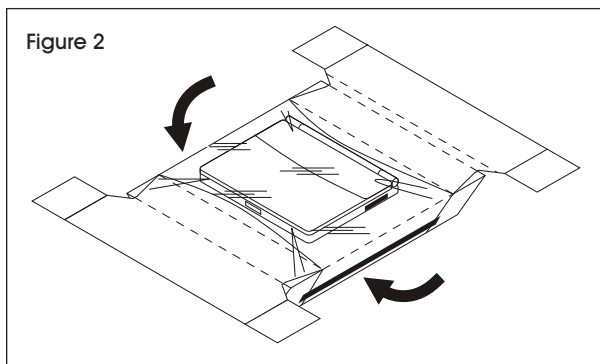

3. Pliez les deux panneaux intérieurs en position verticale. (Voir Figure 3)

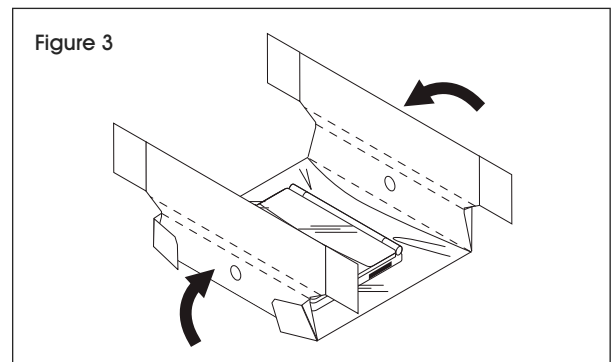

4. Pliez les panneaux extérieurs et les panneaux à oreilles. Tenez les panneaux ensemble pour l'insertion dans la boîte. (Voir Figure 4)

