

ULINE S-20903, S-20904
S-20905
ACE™ ELASTIC BANDAGE

1-800-295-5510
uline.com

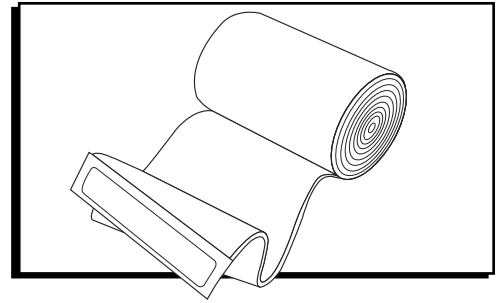

INSTRUCTIONS



IMPORTANT! Before using, you must re-roll the bandage to ensure the fastener is in the proper place for wrapping.

PREPARATION

1. Disconnect the hook closure from bandage. (See Figure 1)

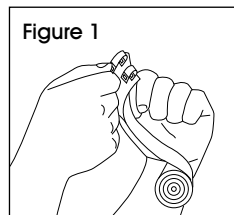

2. Hold bandage so ACE™ label is facing away from you. (See Figure 2)

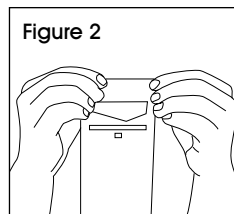

3. Begin re-rolling bandage so the ACE™ label is on the inside. (See Figure 3)

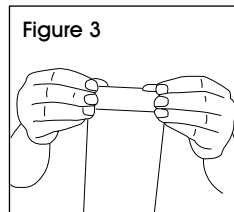

4. With bandage re-rolled, the fastener end will be on the correct side to fasten the bandage after wrapping. (See Figure 4)

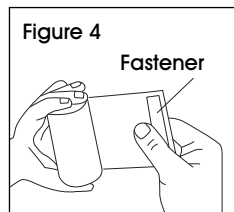

FOOT/ANKLE

1. Start wrapping at ball of foot, continuing under foot from inside to outside. (See Figure 5)

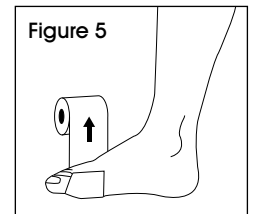

2. Make two or three turns around foot, moving towards ankle with each turn. Overlap half of the previous layer. Begin a figure-eight turn, bringing bandage up outside of foot, over instep and inside around ankle. (See Figure 6)

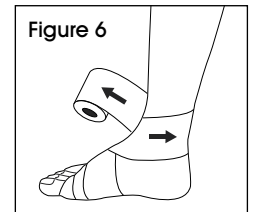

3. Continue down inside of foot around heel, back up over instep, down under foot, and back up completely around ankle. (See Figure 7)

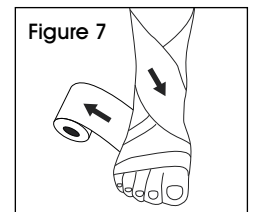

4. Repeat figure-eight two or three times, overlapping half of the previous layer and rising above the ankle. (See Figure 8)

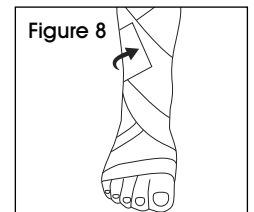

CARE

1. Rinse the bandage in lukewarm soapy water by hand.



NOTE: The antimicrobial treatment lasts for at least 10 washings. To prolong the life of the bandage, do not scrub the bandage.

2. Dry the bandage by laying it out flat on a clean surface. After the bandage has dried, roll the bandage as you would after using it. Smooth out all wrinkles. This is essential for re-bandaging. No ironing is required.

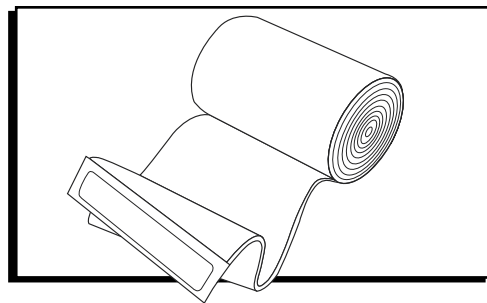

INSTRUCCIONES



¡IMPORTANTE! Antes de usarla, deberá volver a enrollar la venda para asegurarse de que el cierre está colocado en el lugar adecuado para la envoltura.

PREPARACIÓN

1. Despegue el cierre de gancho de la venda. (Vea Diagrama 1)

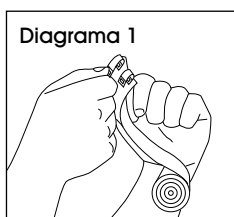

2. Sostenga la venda de forma que la etiqueta de ACE™ mire hacia el lado opuesto a usted. (Vea Diagrama 2)

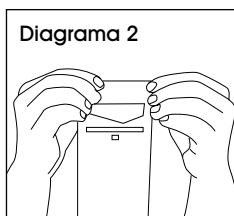

3. Comience a enrollar de nuevo la venda de forma que la etiqueta de ACE™ quede en el interior. (Vea Diagrama 3)

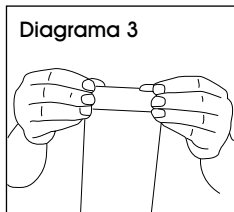

4. Con la venda enrollada de nuevo, el lado del cierre estará en el lado correcto para cerrar el vendaje tras la envoltura. (Vea Diagrama 4)

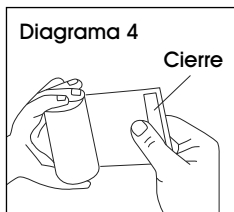

PIE/TOBILLO

1. Comience la envoltura a la altura del metatarso, continuando por debajo del pie de interior a exterior. (Vea Diagrama 5)

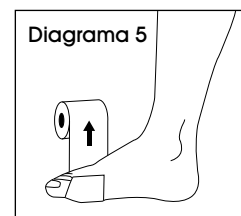

2. Dé dos o tres vueltas alrededor del pie, acercándose al tobillo con cada vuelta. Superponga la mitad de la capa anterior. Comience a trazar la forma de un ocho trayendo la venda desde el exterior del pie, por encima del empeine y por la cara interior del tobillo. (Vea Diagrama 6)

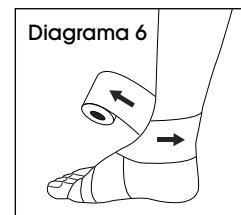

3. Continúe hacia abajo por la cara interior del pie alrededor del tobillo, de nuevo hacia arriba por encima del empeine, hacia abajo por debajo del pie y de nuevo completamente hacia arriba por alrededor del tobillo. (Vea Diagrama 7)

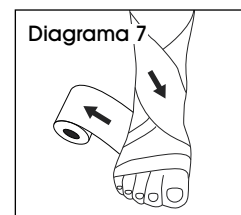

4. Repita la forma de un ocho dos o tres veces, superponiendo la mitad de la capa anterior y elevándola por encima del tobillo. (Vea Diagrama 8)

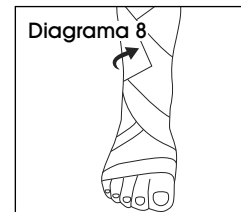

CUIDADO

1. Enjuague la venda a mano en agua jabonosa tibia.



NOTA: El tratamiento antimicrobiano perdura por hasta 10 lavadas. Para aumentar la vida útil de la venda, no la talle.

2. Seque la venda colocándola plana sobre una superficie limpia. Una vez que la venda se haya secado, enrolle la venda como lo haría tras su uso. Quite todas las arrugas. No requiere planchado.

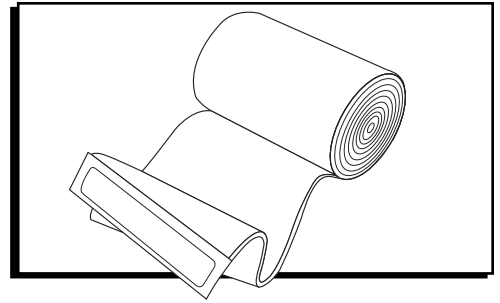

INSTRUCTIONS



IMPORTANT! Avant l'utilisation, vous devez réenrouler le pansement afin que la fermeture soit située au bon endroit pour l'enroulement.

PRÉPARATION

1. Décollez la fermeture autoagrippante du pansement. (Voir Figure 1)

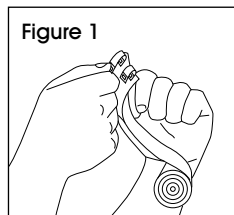

2. Tenez le pansement de façon à ce que l'étiquette ACEMC soit orientée du côté opposé à vous. (Voir Figure 2)

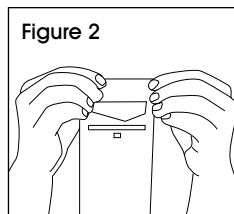

3. Commencez à réenrouler le pansement de façon à ce que l'étiquette ACEMC soit à l'intérieur. (Voir Figure 3)

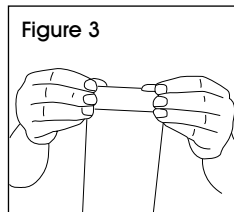

4. Une fois le pansement réenroulé, l'extrémité de la fermeture se trouvera du côté approprié pour fixer le pansement une fois l'enroulement effectué. (Voir Figure 4)

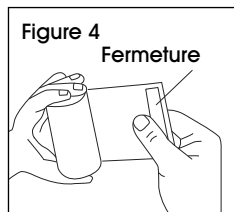

PIED/CHEVILLE

1. Commencez à enrouler le pansement à l'avant-pied, puis sous le pied de l'intérieur vers l'extérieur. (Voir Figure 5)

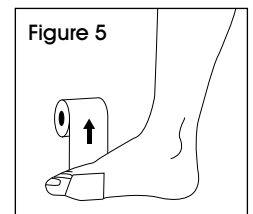

2. Effectuez deux ou trois tours autour du pied, en avançant vers la cheville à chaque tour. Chevauchez la moitié de la couche précédente. Commencez un tour en huit en dirigeant le pansement vers l'extérieur du pied, sur le cou-de-pied et du côté intérieur autour de la cheville. (Voir Figure 6)

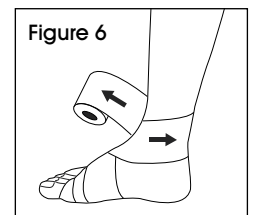

3. Continuez sur l'intérieur du pied autour du talon, remontez sur le cou-de-pied, en baissant sous le pied, et en remontant complètement autour de la cheville. (Voir Figure 7)

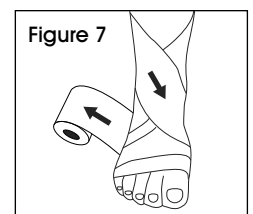

4. Répétez l'opération deux ou trois fois en chevauchant la moitié de la couche précédente et en remontant au-dessus de la cheville. (Voir Figure 8)

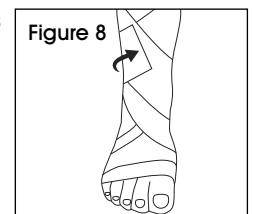

ENTRETIEN

1. Rincez le pansement dans de l'eau tiède savonneuse à la main.



REMARQUE : Le traitement antimicrobien dure au moins 10 lavages. Ne frottez pas le pansement afin de prolonger sa durée de vie.

2. Faites sécher le pansement en le posant à plat sur une surface propre. Une fois le pansement sec, roulez-le comme vous le feriez après l'avoir utilisé. Assurez-vous de lisser tous les plis. Cette étape est indispensable pour réutiliser le pansement. Aucun repassage n'est requis.