

**ULINE** S-21610  
**WINE TOTE – 1 BOTTLE**

1-800-295-5510  
uline.com

Para Español, vea páginas 3-4.  
Pour le français, consulter les pages 5-6.

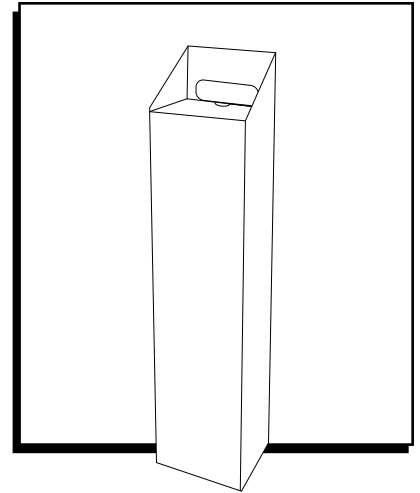

**ASSEMBLY**

1. Push sides in toward the middle to open tote. Flip upside down to assemble the bottom. (See Figure 1)

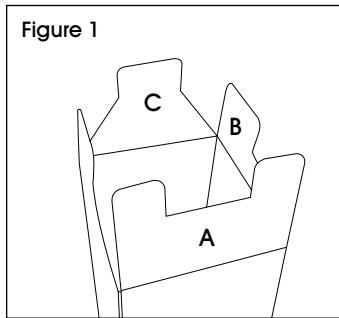

2. Fold flap (A) and then flaps (B) at creases. (See Figures 2-3)

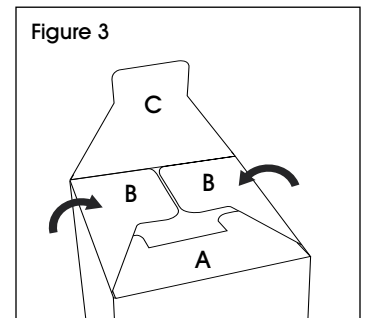
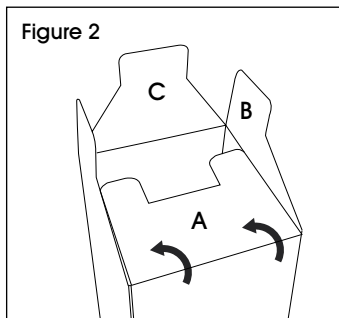

3. Fold flap (C) at crease and tuck inside the middle slot created from step 2. (See Figure 4)
4. Flip the tote over.

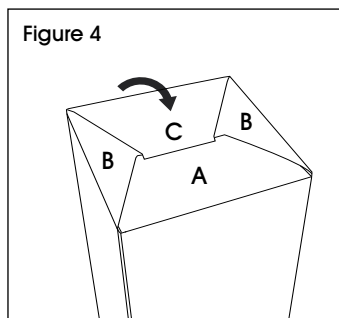

## ASSEMBLY CONTINUED

5. Fold flap (E) down, lining up the hand hole (F) with the hole at the back of the tote (G). Push middle in to create hand hole. (See Figures 5-6)

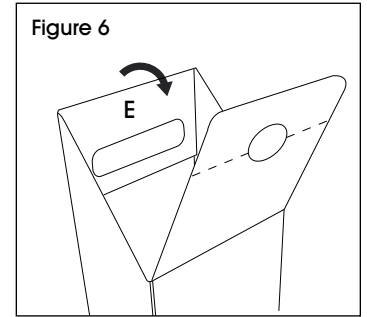
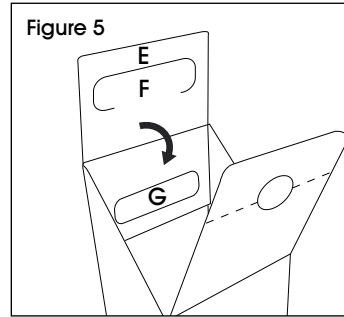

6. Fold flap (H) at both creases, tucking panel in to close. (See Figures 7-8)

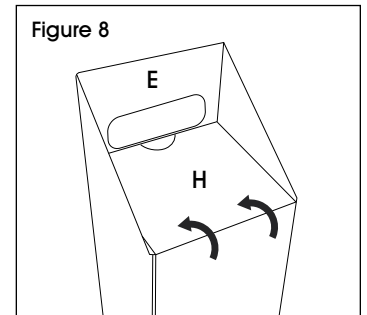
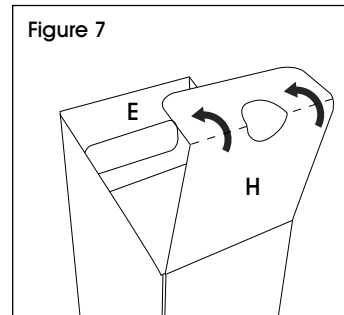

**ULINE**

1-800-295-5510  
uline.com

**ULINE** S-21610

**CAJA CON ASA PARA 1  
BOTELLA DE VINO**

800-295-5510

uline.mx

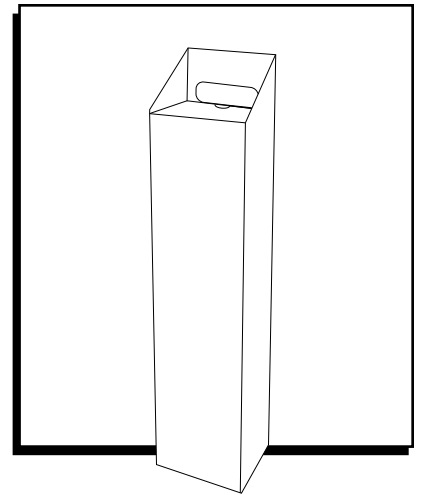

## ENSAMBLE

1. Doble los lados hacia en medio para abrir la caja. Voltéela del lado opuesto para ensamblar la parte inferior. (Vea Diagrama 1)

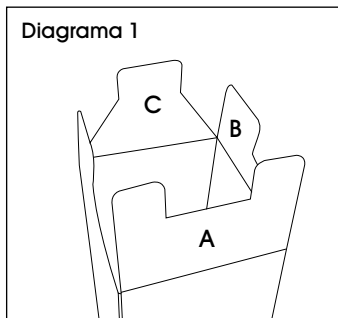

2. Doble la solapa (A) y luego las solapas (B) por los pliegues. (Vea Diagramas 2 y 3)

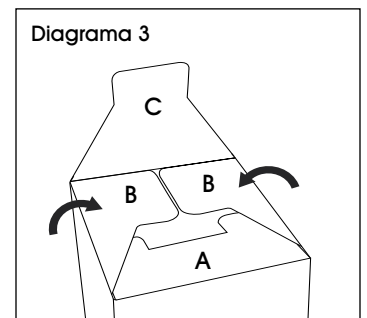
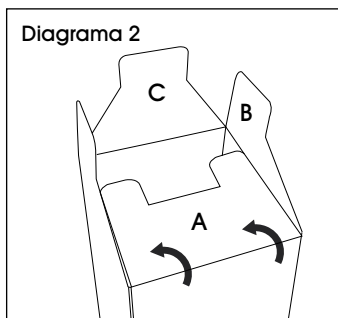

3. Doble la solapa (C) por el pliegue e insértela en la ranura media creada en el paso 2. (Vea Diagrama 4)
4. Vuelva a voltear la caja hacia arriba.

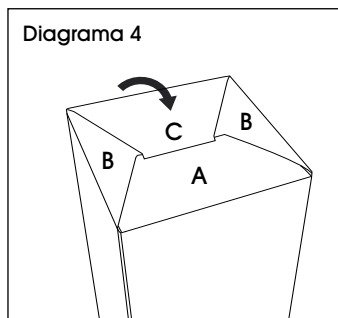

## CONTINUACIÓN DE ENSAMBLE

5. Doble la solapa (E) hacia abajo, alineando la abertura del asa (F) con el orificio de la parte posterior de la caja (G). Inserte la parte media hacia adentro para crear el orificio del asa. (Vea Diagramas 5 y 6)

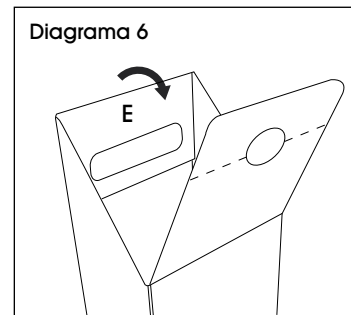
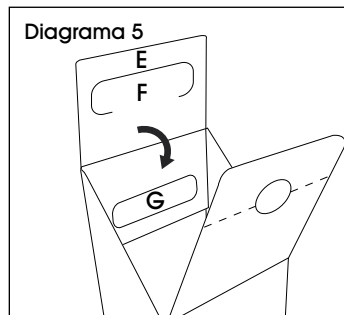

6. Doble la solapa (H) en ambos pliegues, doble el panel hacia adentro para cerrar. (Vea Diagramas 7 y 8)

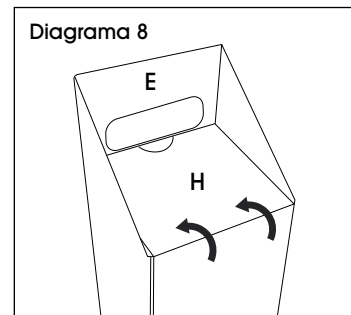
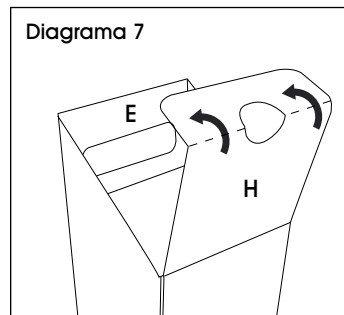

**ULINE**

800-295-5510  
uline.mx

**ULINE S-21610**  
**BOÎTE DE TRANSPORT POUR**  
**LE VIN – 1 BOUTEILLE**

1 800 295-5510  
uline.ca

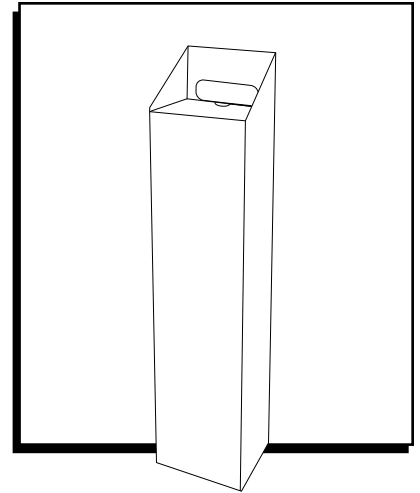

**ASSEMBLAGE**

1. Poussez les côtés à l'intérieur vers le centre pour ouvrir la boîte. Retournez-la à l'envers pour assembler le fond. (Voir Figure 1)

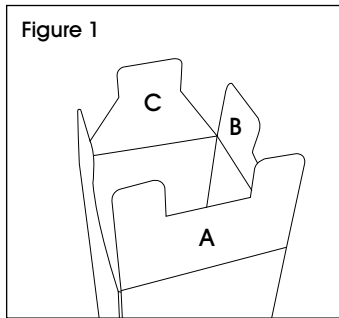

2. Abaissez le rabat (A) et ensuite les rabats (B) aux pliures. (Voir Figures 2 et 3)

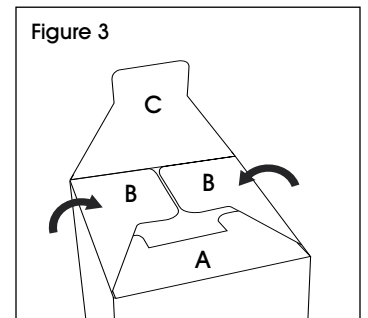
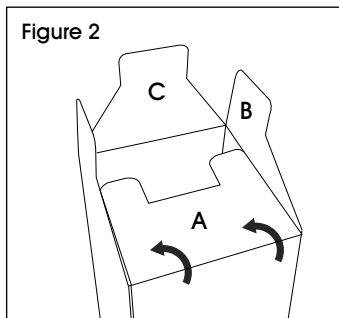

3. Abaissez le rabat (C) à la pliure et insérez dans la fente au centre formée à l'étape 2. (Voir Figure 4)

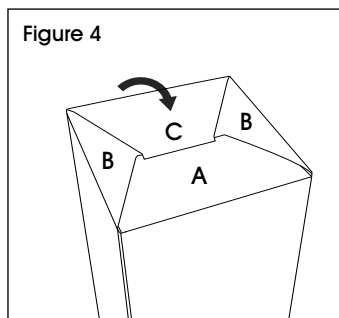

4. Retournez la boîte à l'endroit.

## ASSEMBLAGE SUITE

5. Pliez le rabat (E) vers le bas en alignant l'orifice de poignée (F) sur celui se trouvant à l'arrière de la boîte (G). Poussez le centre vers l'intérieur afin de créer l'orifice de poignée. (Voir Figures 5 et 6)

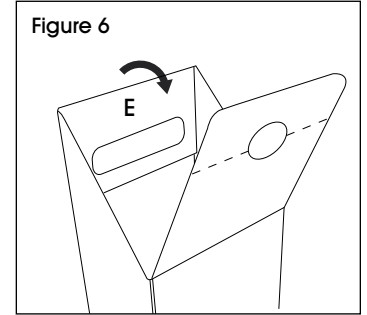
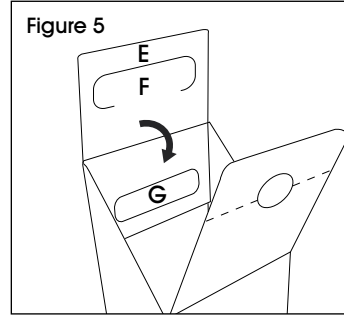

6. Abaissez le rabat (H) aux deux pliures en insérant le panneau à l'intérieur pour fermer. (Voir Figures 7 et 8)

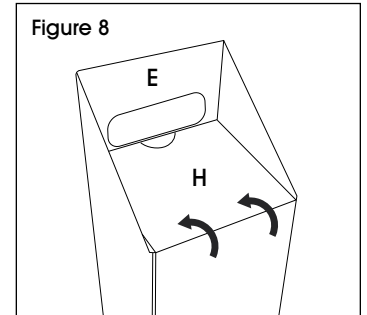
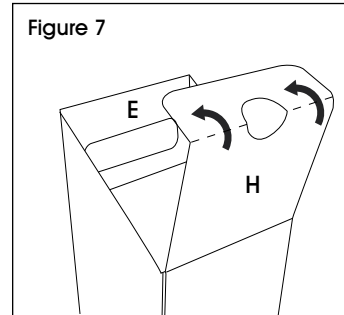

**ULINE**

1 800 295-5510  
uline.ca