

# ULINE S-21861, S-21862

## CORRUGATED PLASTIC RECEPTACLES

1-800-295-5510  
uline.com

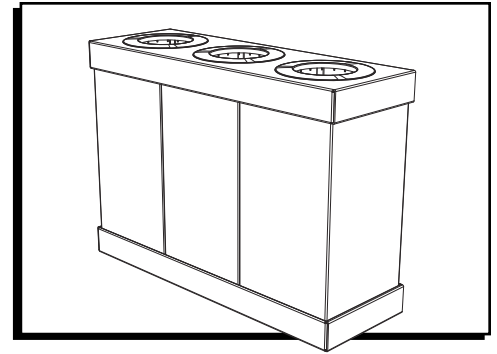

### PARTS

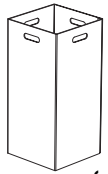

Bin  
(x 2 for S-21861)  
(x 3 for S-21862)

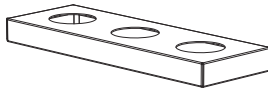

Top x 1

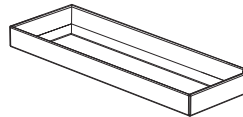

Base x 1



Decal x 4

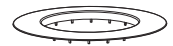

Insert Ring  
(x 2 for S-21861)  
(x 3 for S-21862)

### ASSEMBLY

1. Fold bin open and turn upside down. Fold tab (1) inward, followed by side tabs (2,3), to form bottom of bin. Fold and insert tab (4) into slot in tab (1). Repeat for remaining bins. (See Figure 1)

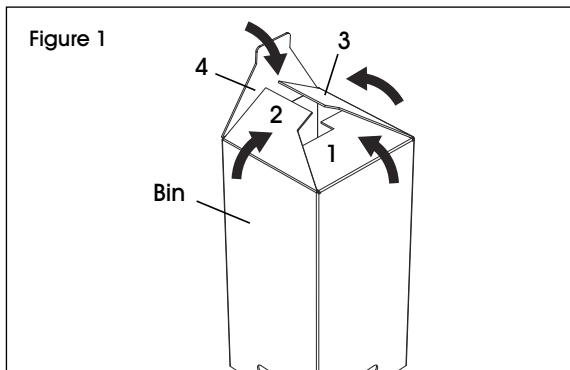

2. Turn bins right side up and press down into base. (See Figure 2)

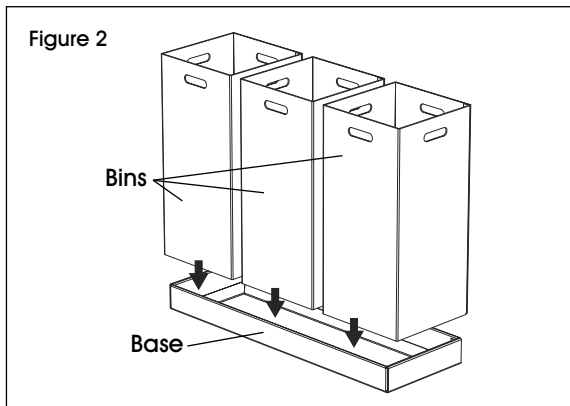

3. Press top down over bins until it rests securely. (See Figure 3)

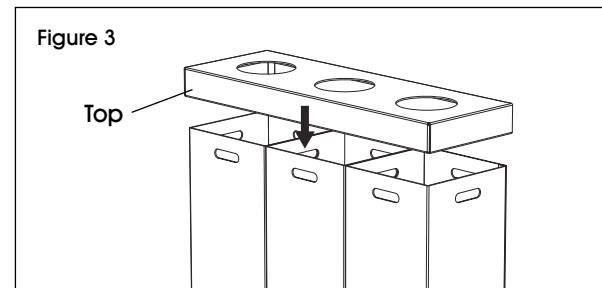

4. To apply decals to insert rings:

- a. Remove protective liner.
- b. Place in position.
- c. Press to secure.
- d. Remove top liner. (See Figure 4)

Figure 4

Decal



Insert Ring

5. Press insert rings into holes in top. (See Figure 5)

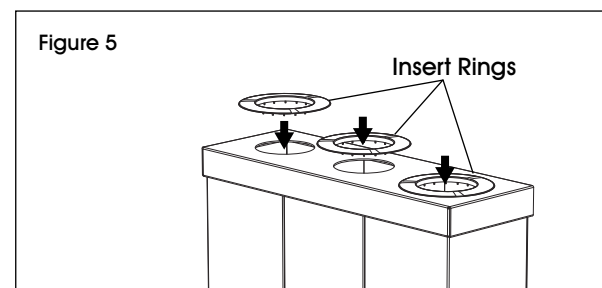

**ULINE** S-21861, S-21862

# BOTES DE BASURA DE PLÁSTICO CORRUGADO

800-295-5510

uline.mx

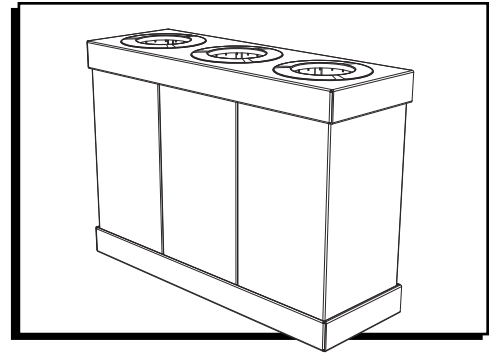

## PARTES

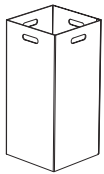

Contenedores  
(2 para el S-21861)  
(3 para el S-21862)

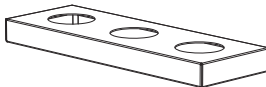

1 Cubierta

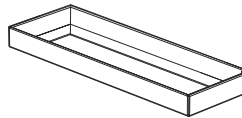

1 Base



4 Calcomanías



Insertos de Anillos  
(2 para el S-21861)  
(3 para el S-21862)

## ENSAMBLE

1. Doble las solapas para abrir el bote y colóquelo boca abajo. Doble la solapa (1) hacia adentro, seguida de las solapas laterales (2 y 3) para crear el fondo del bote. Doble e introduzca la solapa (4) en la ranura de la solapa (1). Repita en los botes restantes. (Vea Diagrama 1)

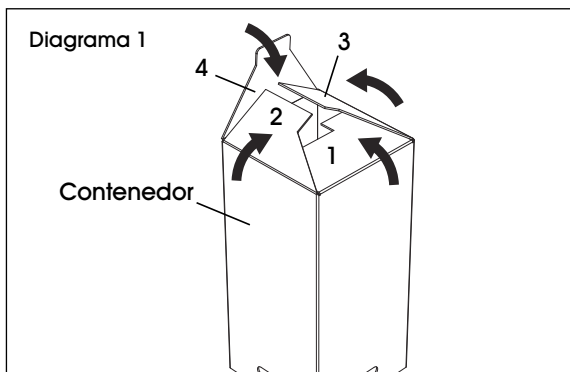

2. Enderece los contenedores y presiónelos hacia abajo dentro de la base. (Vea Diagrama 2)

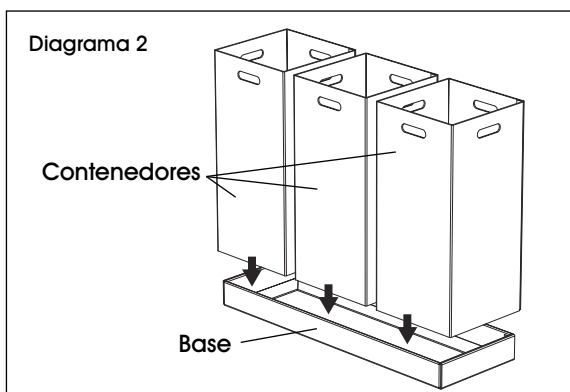

3. Presione la cubierta sobre los contenedores hasta que queden fijos. (Vea Diagrama 3)

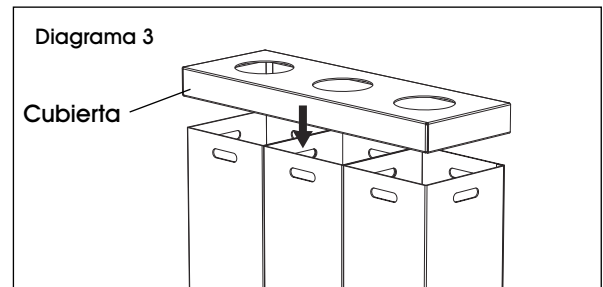

4. Para poner las calcomanías a los insertos de anillos:
  - a. Retire el forro protector.
  - b. Colóquela en posición.
  - c. Presiónela para fijarla.
  - d. Retire el forro superior. (Vea Diagrama 4)

Diagrama 4

Calcomanía



Inserto de Anillo

5. Presione los insertos de anillo dentro de los orificios en la cubierta. (Vea Diagrama 5)

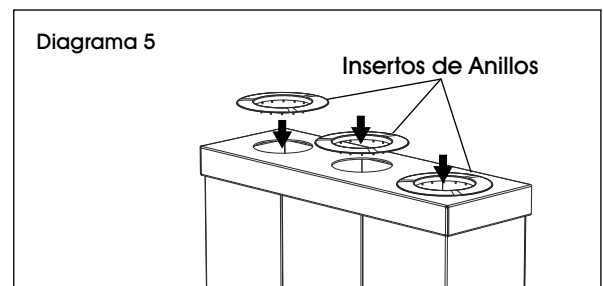

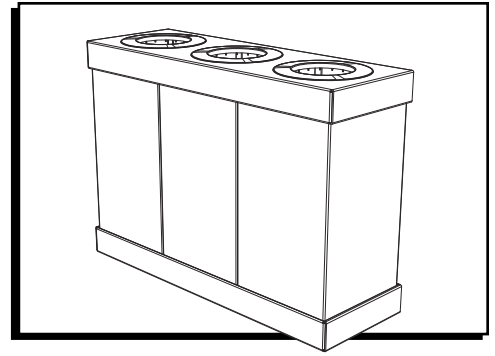
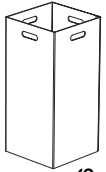
**PIÈCES**

Bac  
(2 pour le S-21861)  
(3 pour le S-21862)

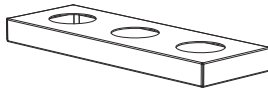

Dessus x 1

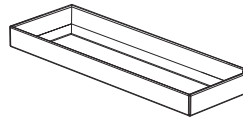

Base x 1



Décalque x 4



Bague d'insertion  
(2 pour le S-21861)  
(3 pour le S-21862)

**ASSEMBLAGE**

1. Dépliez le bac et placez-le à l'envers. Pliez la languette (1) vers l'intérieur, suivie des languettes (2,3), pour former le fond du bac. Pliez et insérez la languette (4) dans la fente de la languette (1). Répétez la procédure pour les autres bacs. (Voir Figure 1)

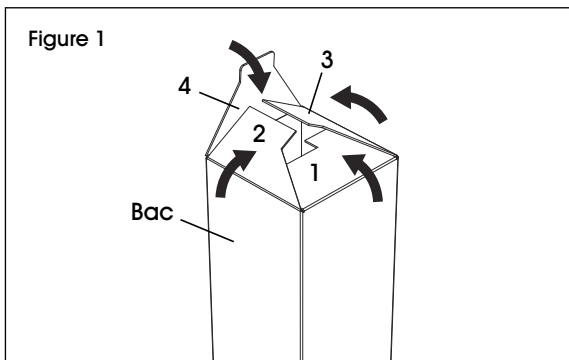

2. Placez les bacs à l'endroit, puis insérez-les dans la base en poussant. (Voir Figure 2)

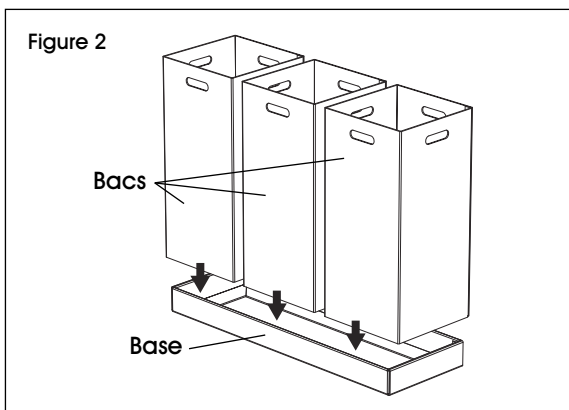

3. Installez le dessus sur les bacs en poussant vers le bas jusqu'à ce qu'il reste fermement en place. (Voir Figure 3)

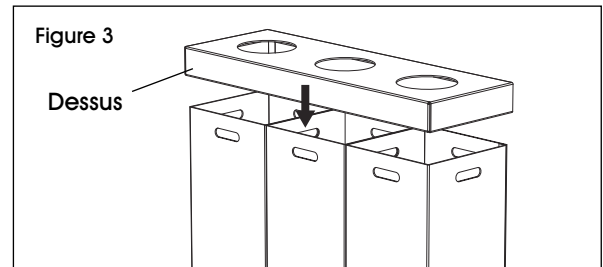

4. Pour appliquer les décalques sur les bagues d'insertion :

- a. Retirez la doublure de protection.
- b. Mettre le décalque en position.
- c. Appuyez fermement en place.

Figure 4

Décalque



Bague d'insertion

- d. Retirez la doublure supérieure. (Voir Figure 4)

5. Installez les bagues d'insertion en les poussant dans les trous du dessus. (Voir Figure 5)

