

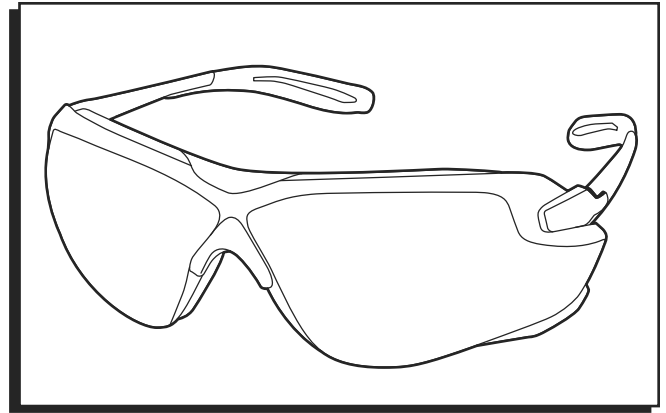

ULINE S-24605 IMPULSE SAFETY GLASSES

1-800-295-5510
uline.com



CONVERTING TO GOGGLES

 **NOTE:** Frame and lenses are made of polycarbonate and will not break during goggle assembly.

1. Fold the arm into the closed position. (See Figure 1)

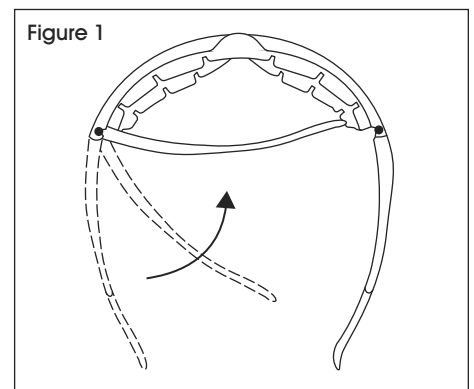

2. Rotate the arm straight down until it snaps off the hinge of the frame. (See Figure 2)

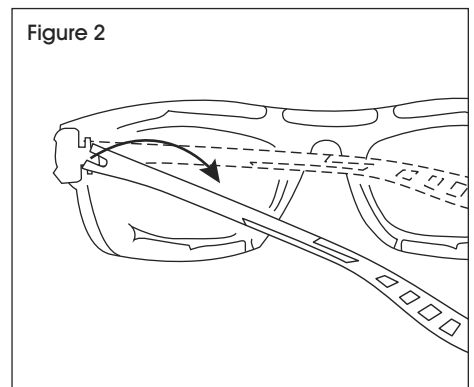

3. Place the goggle clip onto the hinge of the frame. Press firmly until it snaps into place. (See Figure 3)

 **NOTE:** Goggle straps are labeled "L" and "R" for left and right side of frame.

4. Repeat steps 1 through 3 for second arm.

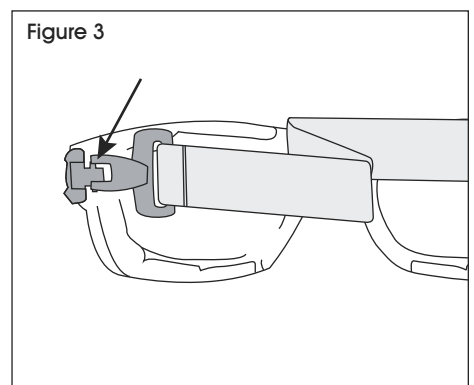

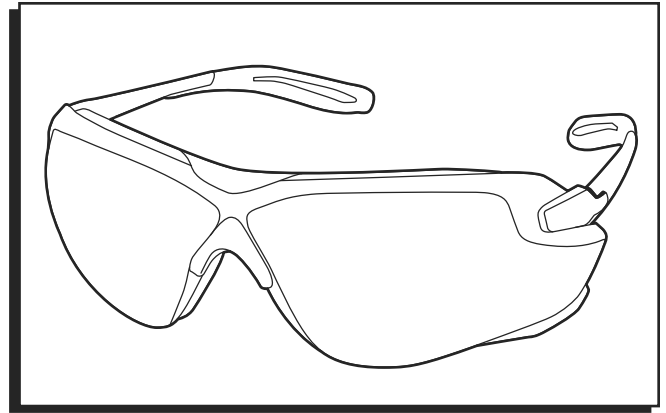

CONVERSIÓN A GOGGLES

 **NOTA:** El armazón y los lentes están fabricados en policarbonato y no se romperán durante la conversión a goggles.

1. Pliegue la patilla a la posición cerrada. (Vea Diagrama 1)

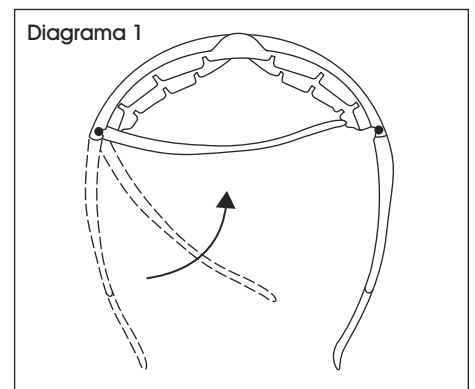

2. Gire la patilla hacia abajo hasta que se desprenda de la bisagra del armazón. (Vea Diagrama 2)

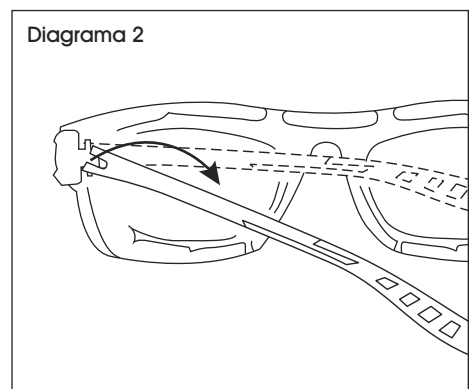

3. Coloque el clip del goggle en la bisagra del armazón. Presione con firmeza hasta que encaje en su lugar. (Vea Diagrama 3)

 **NOTA:** Las correas de los goggles están etiquetadas con "L" y "R" para los lados izquierdo y derecho del armazón.

4. Repita los pasos del 1 al 3 para la segunda patilla.

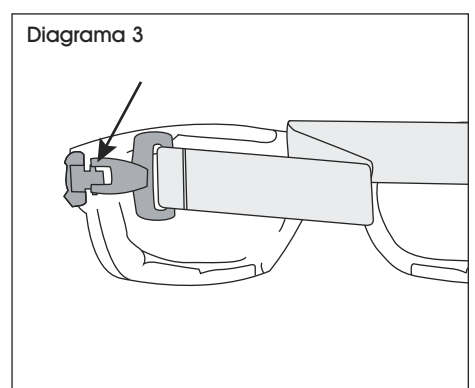

ULINE S-24605

**IMPULSE – LUNETTES
DE SÉCURITÉ**

1-800-295-5510
uline.ca

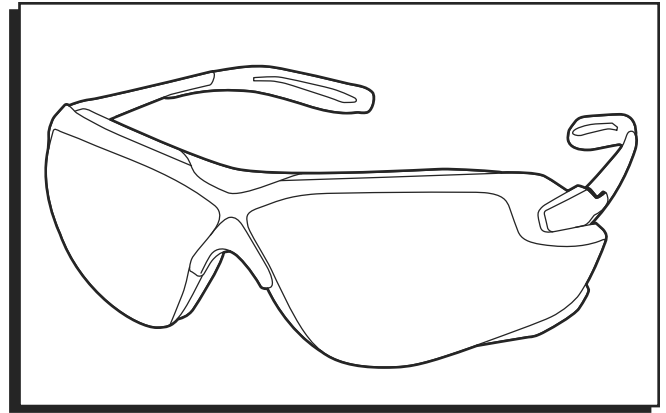

CONVERSION EN LUNETTES DE SÉCURITÉ



REMARQUE : La monture et les lentilles sont en polycarbonate et ne se briseront pas lors de l'assemblage.

1. Repliez les branches en position fermée.
(Voir Figure 1)

Figure 1

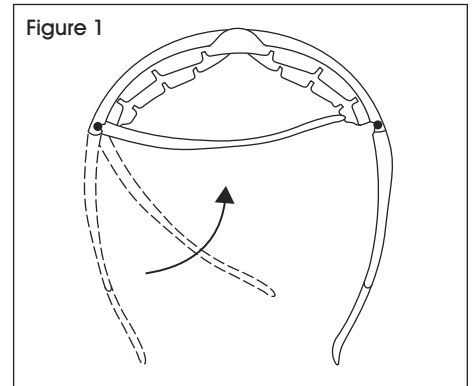

2. Faites pivoter la branche vers le bas jusqu'à ce qu'elle se détache de la charnière de la monture.
(Voir Figure 2)

Figure 2

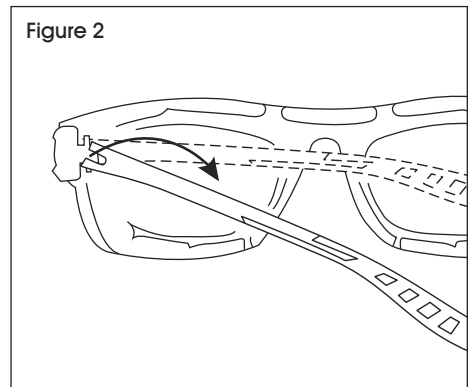

3. Placez la jointure du serre-tête dans la charnière de la monture. Appuyez fermement jusqu'à ce qu'il s'enclenche en place. (Voir Figure 3)



REMARQUE : Le serre-tête des lunettes sont étiquetés « L » et « R » pour les côtés gauche et droit de la monture.

4. Répétez les étapes 1 à 3 pour la seconde branche.

Figure 3

