

ULINE S-26110

**DOUBLE DECKER
UTILITY WAGON**

1-800-295-5510

uline.com

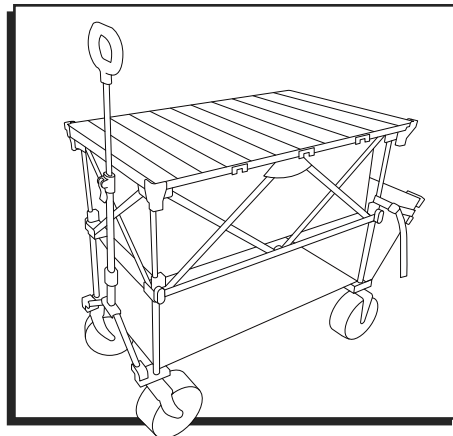

PARTS

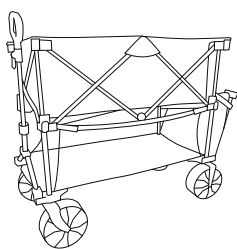

Wagon x 1

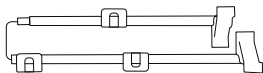

Table Mount x 2

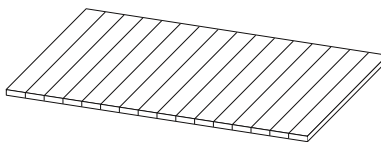
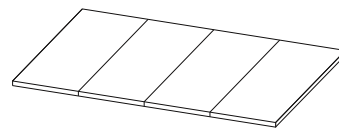

Table x 1



Base Plate x 1

INSTRUCTIONS

UNFOLDING

1. Unfasten both side straps from frame loops. Unzip and remove cover. (See Figure 1)

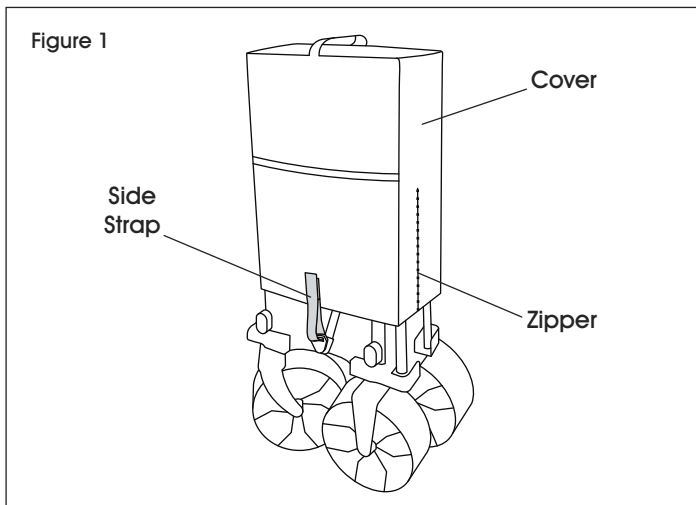

2. Unfasten strap around frame. (See Figure 2)

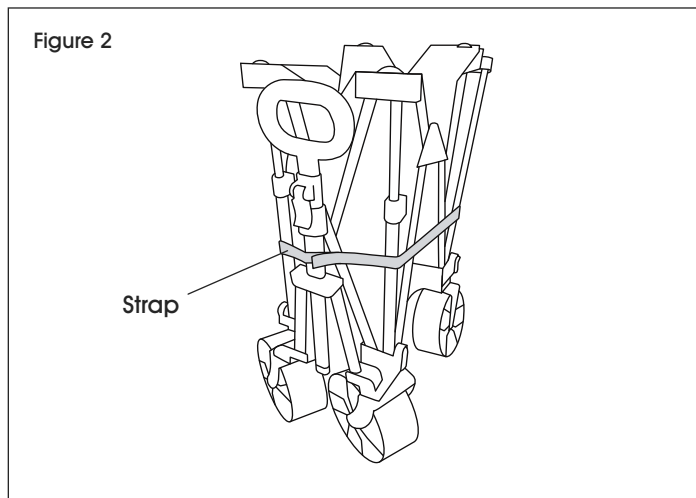

INSTRUCTIONS CONTINUED

3. Push down on center of upper level to open wagon.
(See Figure 3)

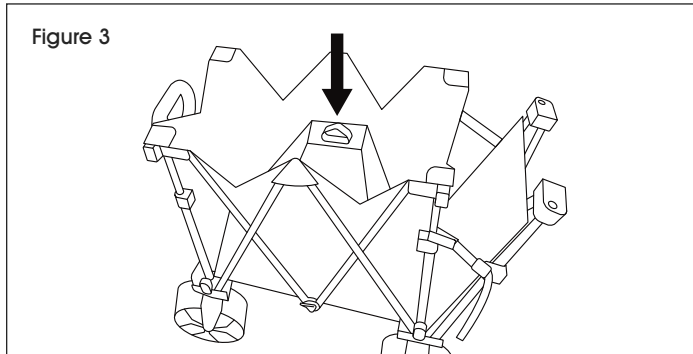

4. Grab and lift both end loops to expand and lock legs into extended position. (See Figure 4)

 **NOTE:** An audible click will be heard when leg buttons lock in extended position.

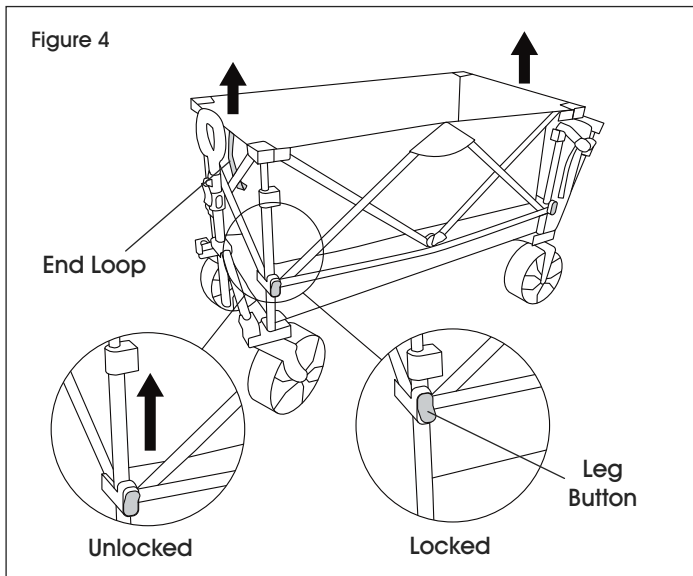

5. Unfold and place base plate into top of wagon for added support. (See Figure 5)

 **NOTE:** Push down on center of lower level to ensure wagon is fully open.

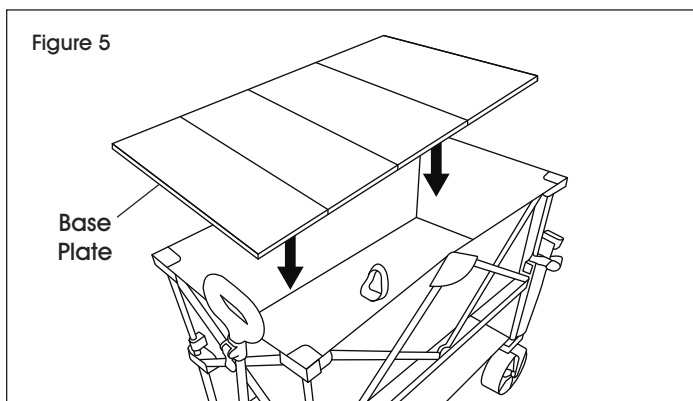

6. Pull handle up to lock handle arm into place. An audible click will be heard when handle tabs lock into place. (See Figure 6)
7. To adjust handle, lift locking lever up, extend handle to desired length, then push locking lever down to secure. (See Figure 7)

 **NOTE:** This adjustment allows for up to 6" of additional length.

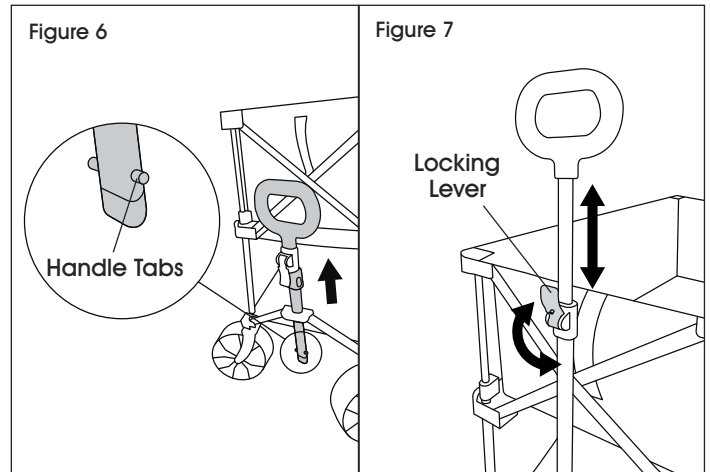

8. Before use, tuck straps on door into door pocket. (See Figure 8)

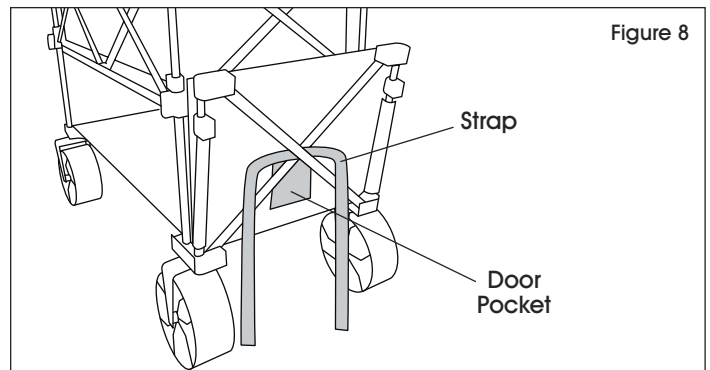

9. Adjust door straps to raise and lower tailgate. (See Figure 9)

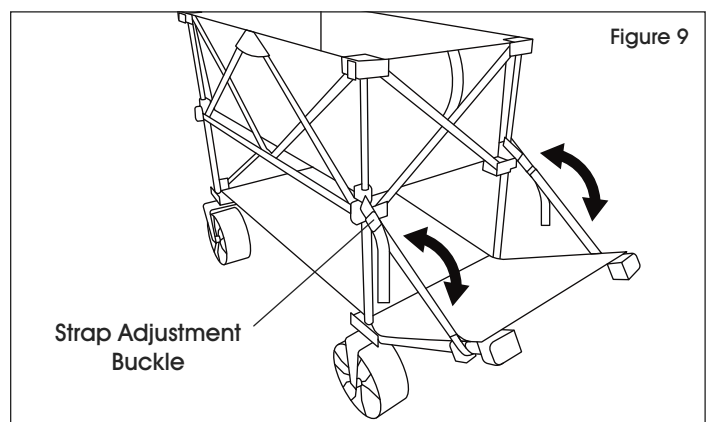

INSTRUCTIONS CONTINUED

ATTACHING THE TABLE

1. Connect table mounts. (See Figure 10)



IMPORTANT! Ensure mount ends are facing the same direction.

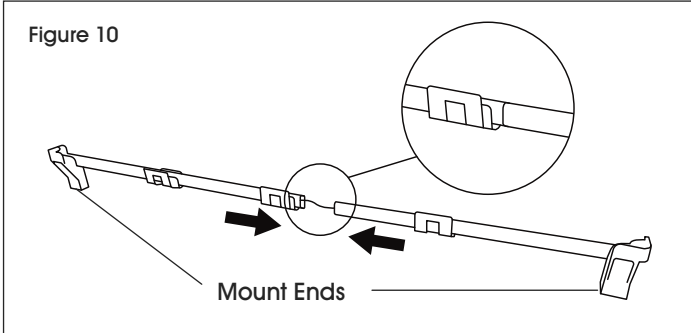

2. Slide connected table mounts onto outside corners of wagon frame with L-Brackets facing up. (See Figure 11)

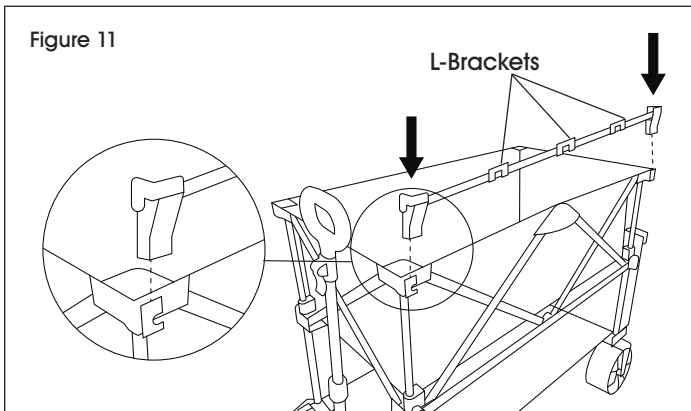

3. Unroll and slide table into corners of table mounts. Table edges should rest inside the L-Brackets. (See Figure 12)

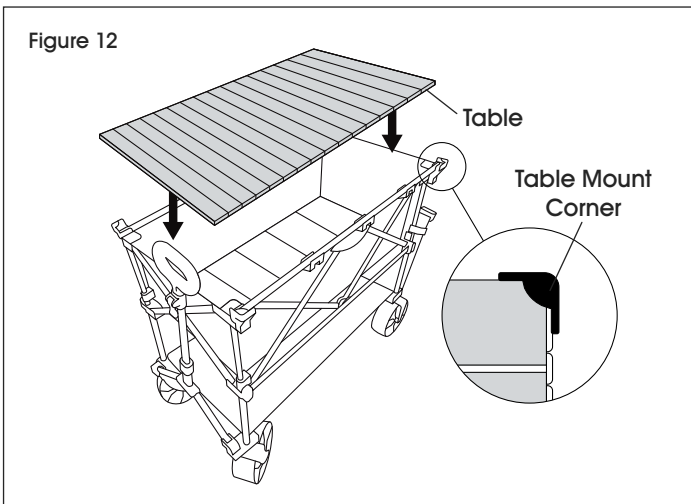

FOLDING



IMPORTANT! Remove tabletop and table mounts if installed before proceeding.

1. Remove the base plate. (See Figure 13)

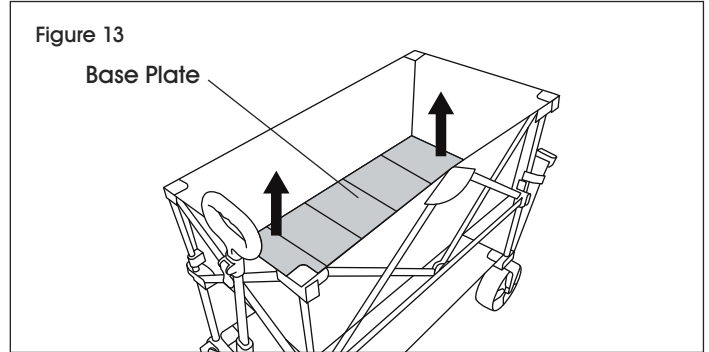

2. Press leg button while lightly pushing down top corner to collapse wagon. Repeat for remaining corners. (See Figure 14)

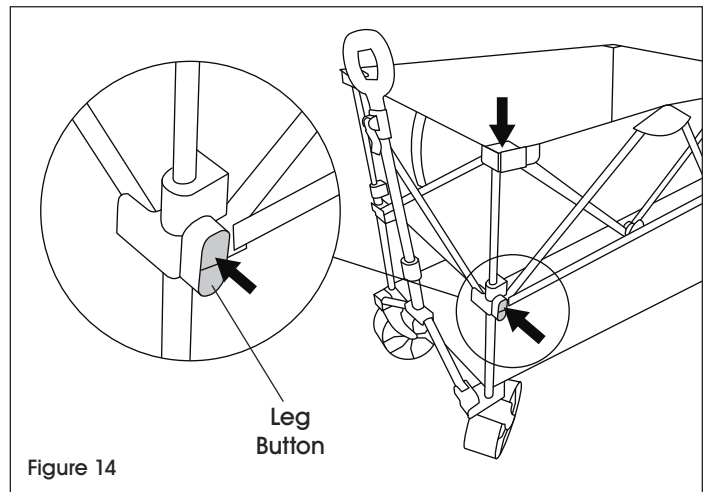

3. Shorten handle using locking lever. Press handle buttons to collapse handle arm. (See Figures 15-16)

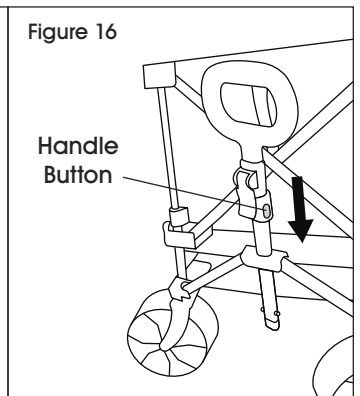
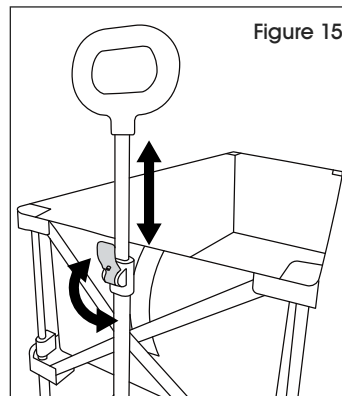

INSTRUCTIONS CONTINUED

4. Pull up on the handle in the middle of the top level of the wagon to collapse. (See Figure 17)

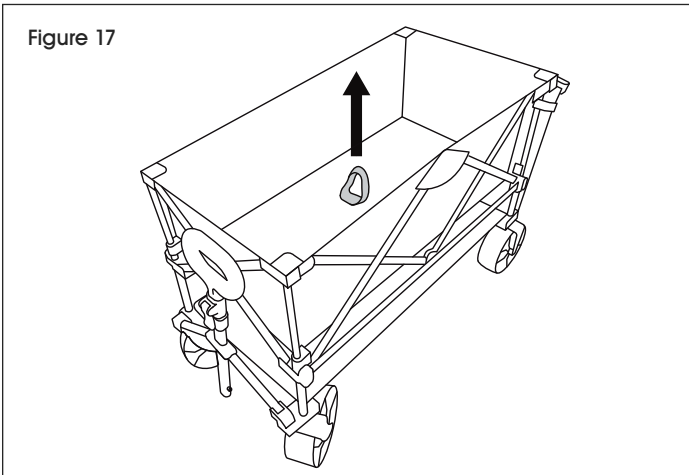

5. Tightly secure strap around frame. (See Figure 18)

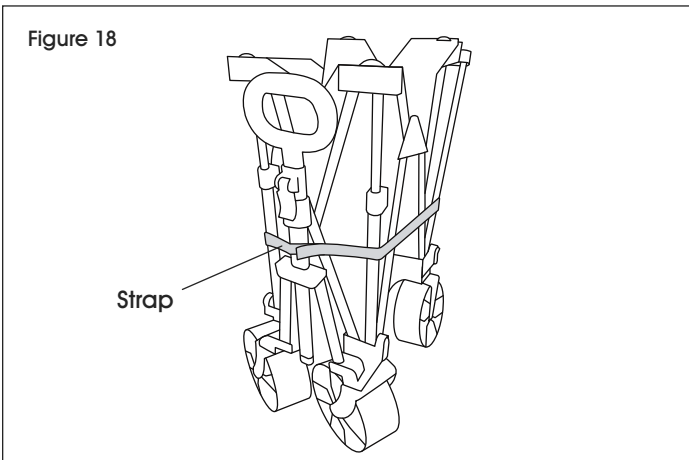

6. Place unzipped cover over wagon. Fasten straps through frame loops to secure. (See Figure 19)

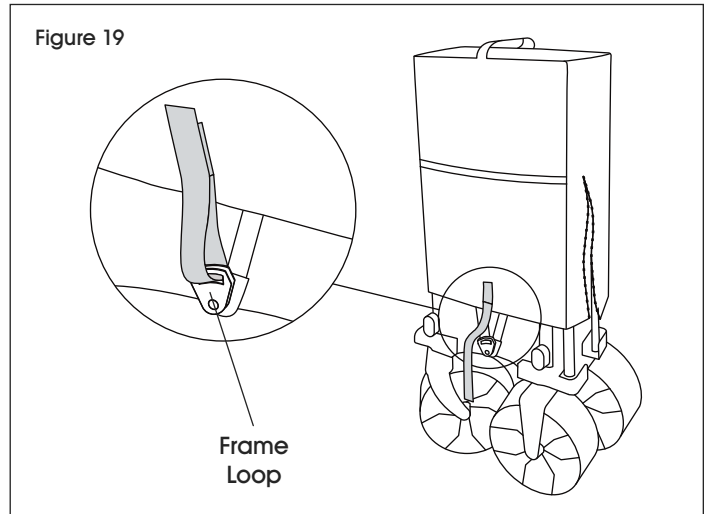

7. Zip cover closed and place folded base plate into bag pocket on cover. (See Figure 20)

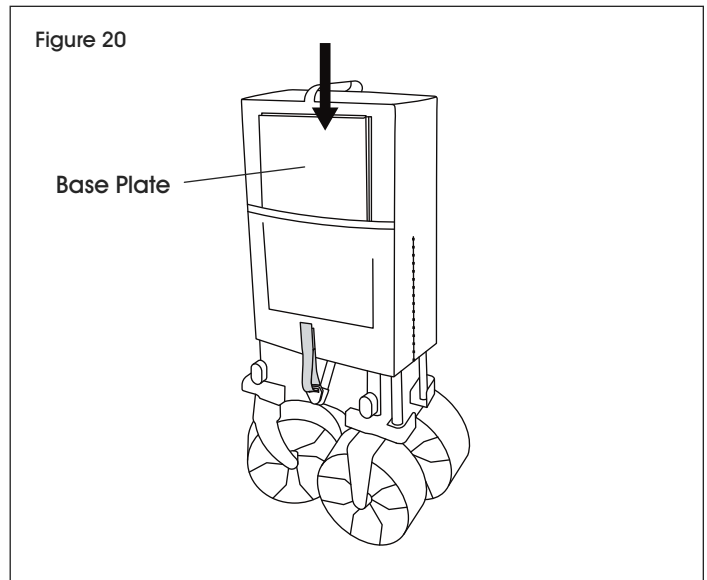

ULINE

1-800-295-5510
uline.com

ULINE S-26110

**CARRITO MULTIUSO
DE DOS NIVELES**

800-295-5510
uline.mx

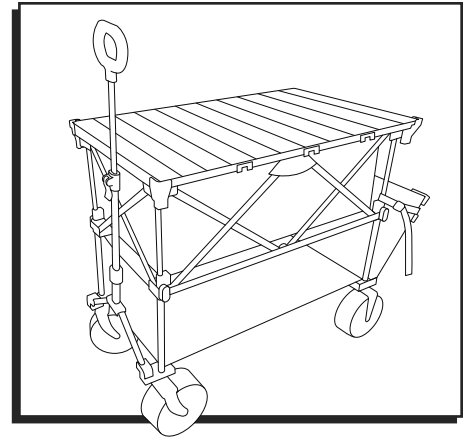

PARTES

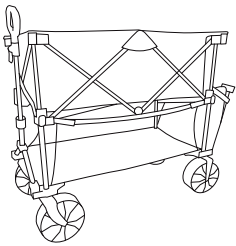

1 Carrito

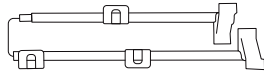

2 Bases de Mesa

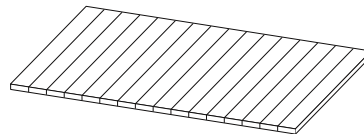

1 Mesa

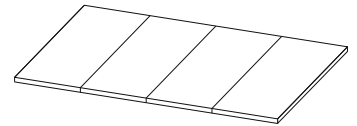

1 Placa de Base

INSTRUCCIONES

DESPLEGAR

1. Desate ambas correas laterales de los lazos del armazón. Abra y saque la cubierta.
(Vea Diagrama 1)

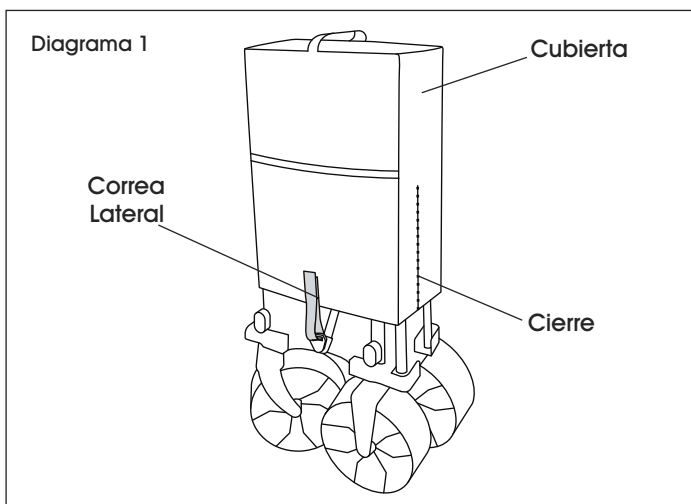

2. Desate la correa alrededor del armazón.
(Vea Diagrama 2)

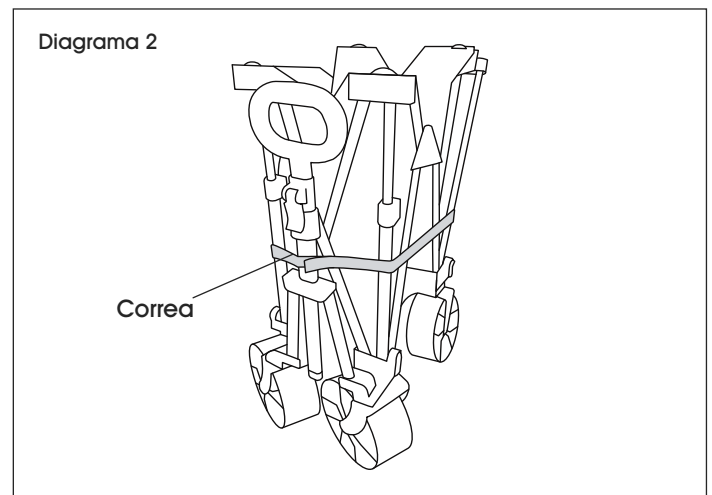

CONTINUACIÓN DE LAS INSTRUCCIONES

3. Presione el centro del nivel superior para abrir el carrito. (Vea Diagrama 3)

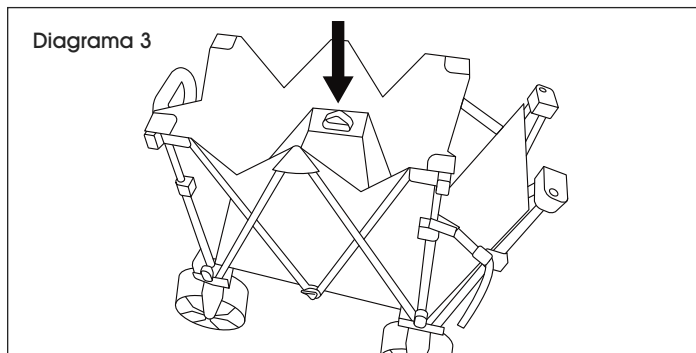

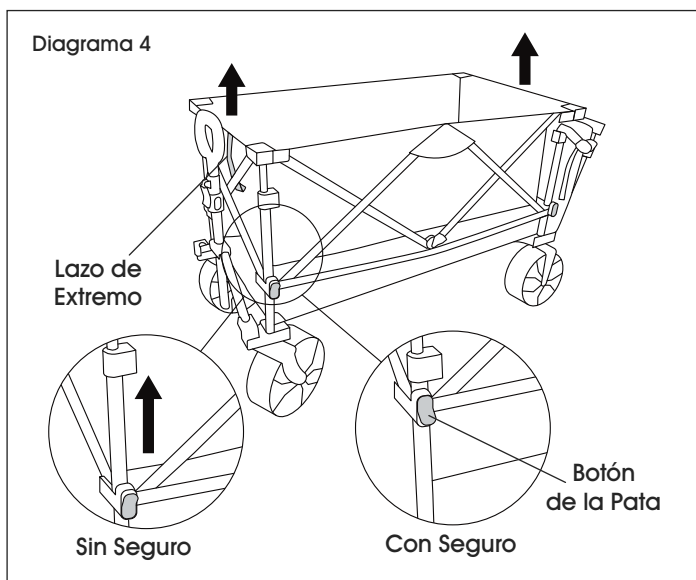

4. Sujete y levante ambos lazos de los extremos y asegure las patas en posición extendida. (Vea Diagrama 4)

 **NOTA:** Escuchará un clic cuando los botones de las patas se aseguren en la posición extendida.

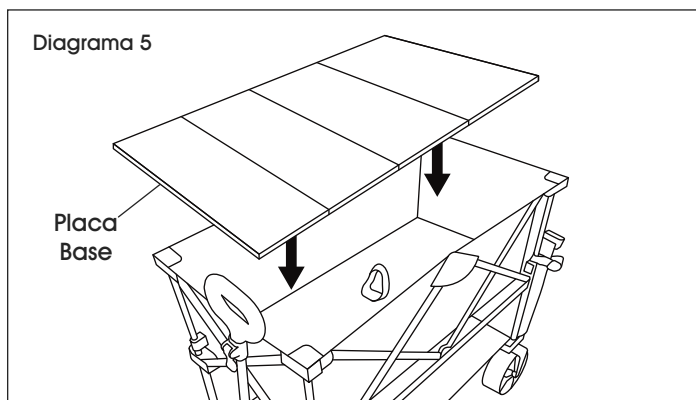

5. Despliegue y coloque la placa de base encima del carrito para soporte adicional. (Vea Diagrama 5)



 **NOTA:** Presione el centro del nivel inferior para asegurarse de que el carrito esté abierto por completo.

6. Jale el asa hacia arriba para asegurar el brazo del asa en su lugar. Escuchará un clic cuando las pestañas del asa se fijen en su lugar. (Vea Diagrama 6)
7. Para ajustar el asa, levante el seguro de la palanca, extienda el asa al largo deseado, luego empuje hacia abajo la palanca para asegurarla. (Vea Diagrama 7)

 **NOTA:** Este ajuste permite hasta 15.2 cm (6") de longitud adicional.

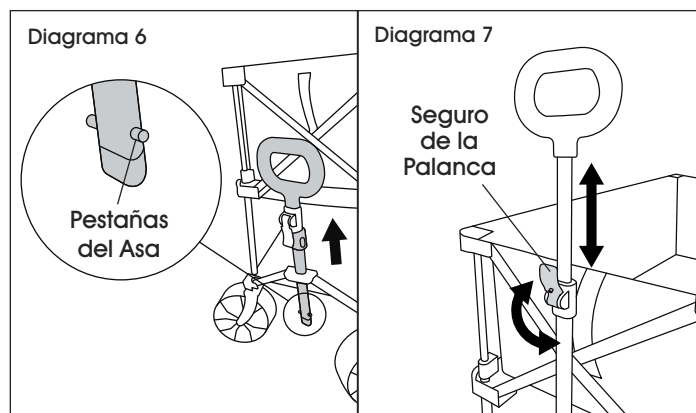

8. Antes del uso, inserte las correas de la plataforma en el bolsillo de la puerta. (Vea Diagrama 8)

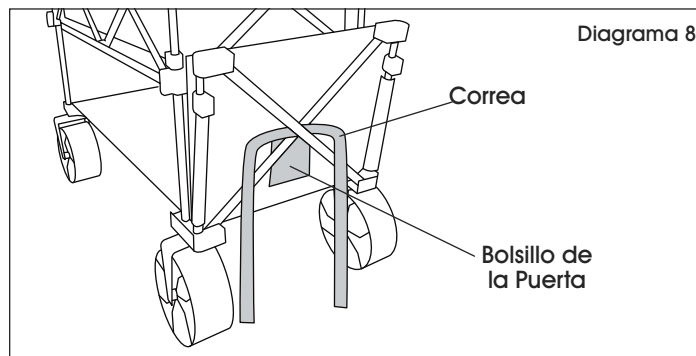

9. Ajuste las correas de la plataforma para elevar y bajar la plataforma inferior del carrito. (Vea Diagrama 9)

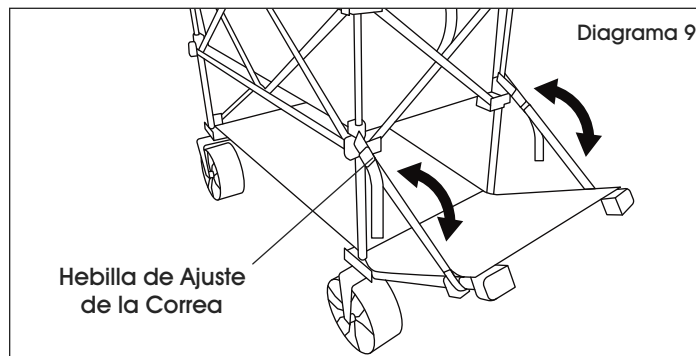

CONTINUACIÓN DE LAS INSTRUCCIONES

FIJAR LA MESA

1. Conecte las bases de la mesa. (Vea Diagrama 10)



¡IMPORTANTE! Asegúrese de que los extremos de la base apunten a la misma dirección.

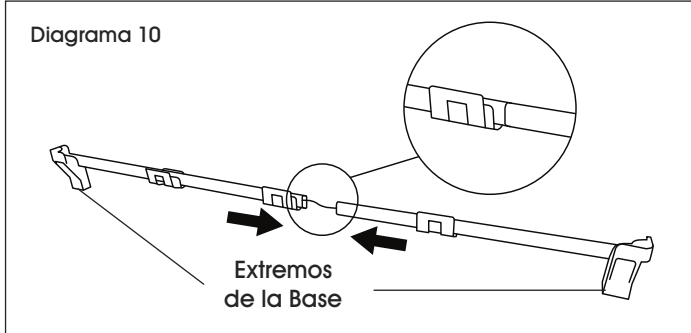

2. Deslice las bases de la mesa conectadas en las esquinas exteriores del armazón del carrito con los Soportes en L hacia arriba. (Vea Diagrama 11)

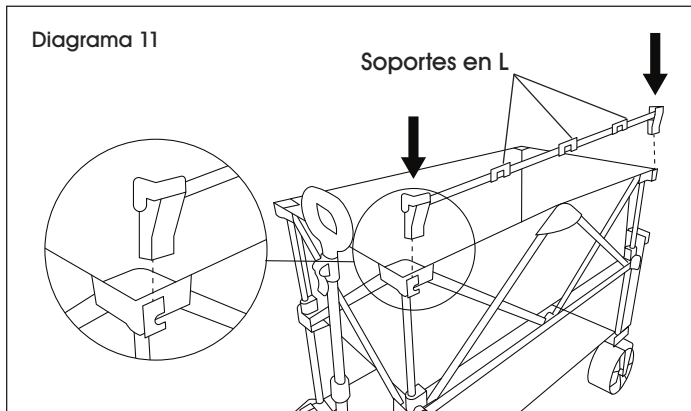

3. Desenrolle y deslice la mesa en las esquinas de las bases de la mesa. Los bordes de la mesa deben quedar dentro de los Soportes en L. (Vea Diagrama 12)

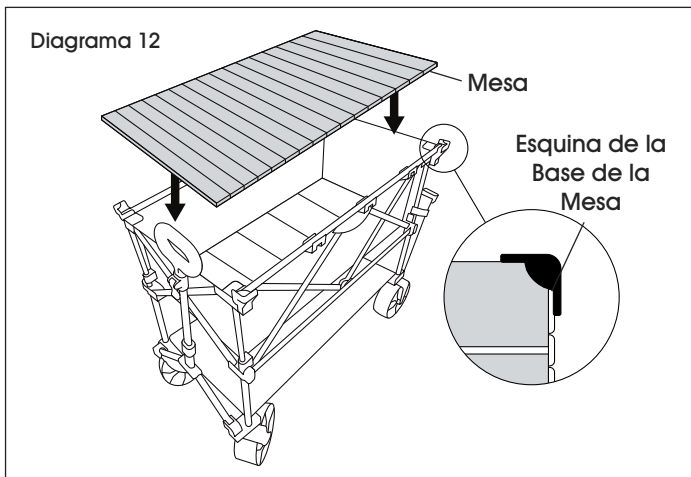

PLEGAR



¡IMPORTANTE! Antes de proceder, retire la cubierta y bases de la mesa, si están instaladas.

1. Retire la placa de base. (Vea Diagrama 13)

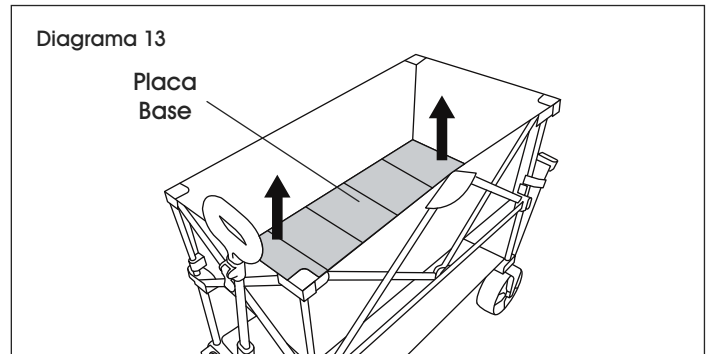

2. Presione el botón de la pata mientras presiona ligeramente la esquina superior para colapsar el carrito. Repita con las esquinas restantes. (Vea Diagrama 14)

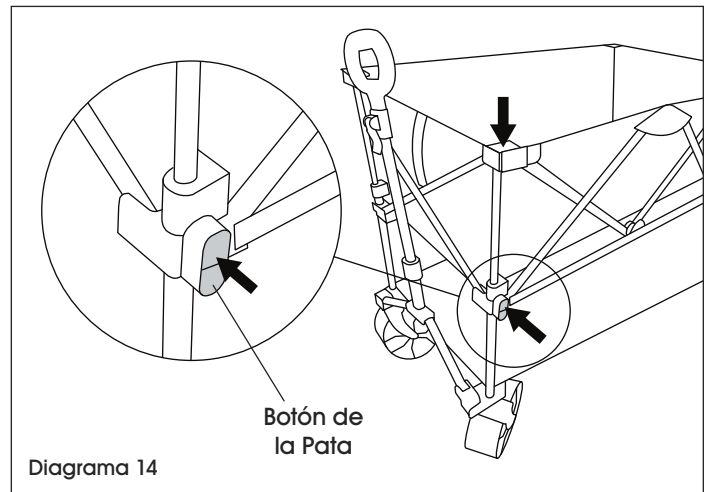

3. Acorte el asa utilizando el seguro de la palanca. Presione los botones del asa para colapsar el brazo del asa. (Vea Diagramas 15-16)

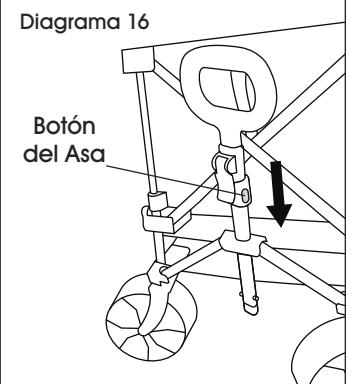
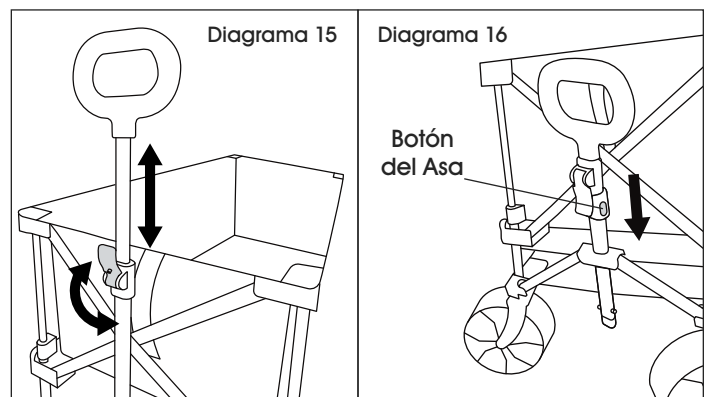

CONTINUACIÓN DE LAS INSTRUCCIONES

4. Jale el asa hacia arriba en medio del nivel superior del carrito para colapsarla. (Vea Diagrama 17)

Diagrama 17

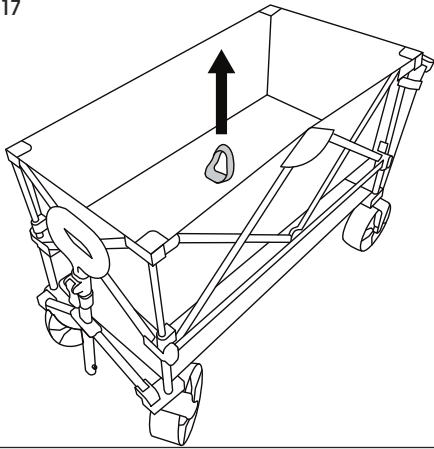

5. Asegure firmemente la correa alrededor del armazón. (Vea Diagrama 18)

Diagrama 18

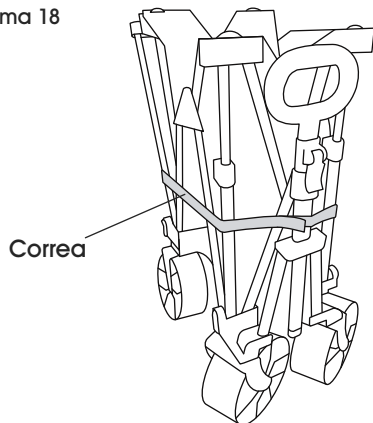

6. Coloque la cubierta sin cerrar sobre el carrito. Asegure las correas a través de los lazos del armazón para asegurarlo. (Vea Diagrama 19)

Diagrama 19

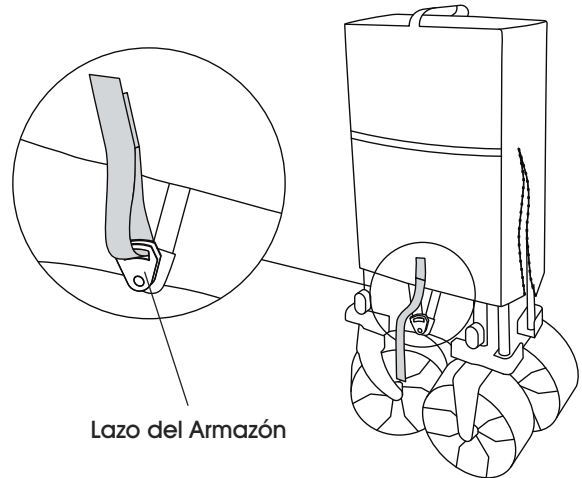

7. Suba el cierre y coloque la placa base plegada en el bolsillo de la cubierta. (Vea Diagrama 20)

Diagrama 20

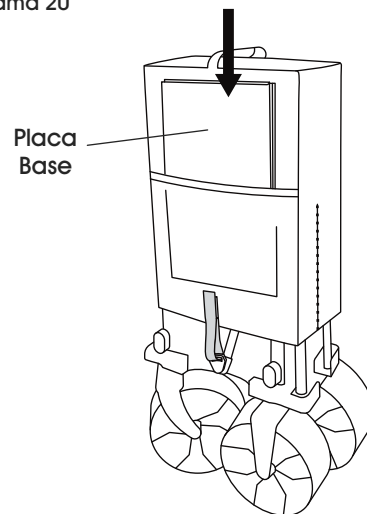

ULINE

800-295-5510

uline.mx

ULINE S-26110

CHARIOT UTILITAIRE À DEUX ÉTAGES

1 800 295-5510
uline.ca

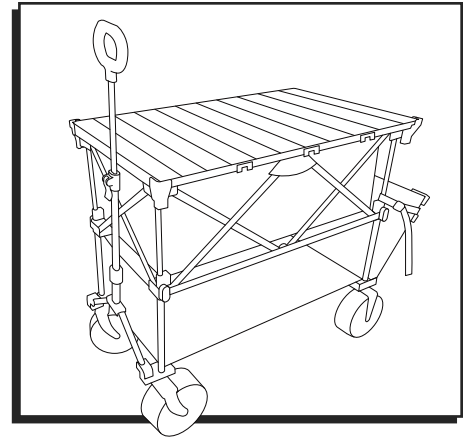

PIÈCES

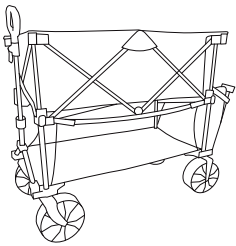

Chariot x 1

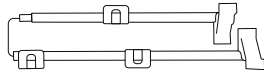

Support de table x 2

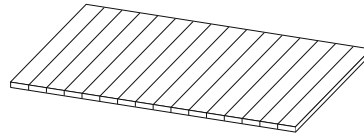
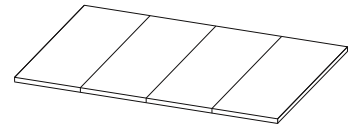

Table x 1



Plaque de base x 1

INSTRUCTIONS

DÉPLIEMENT

1. Détachez les deux sangles latérales des boucles du cadre. Ouvrez la fermeture à glissière et retirez la housse. (Voir Figure 1)

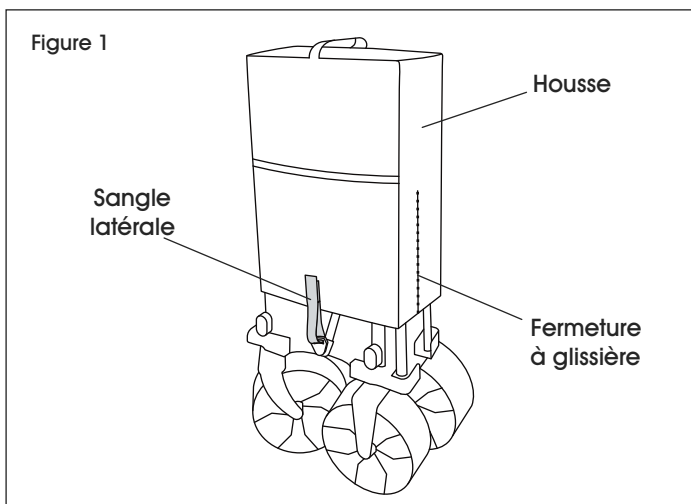

2. Détachez la sangle autour du cadre. (Voir Figure 2)

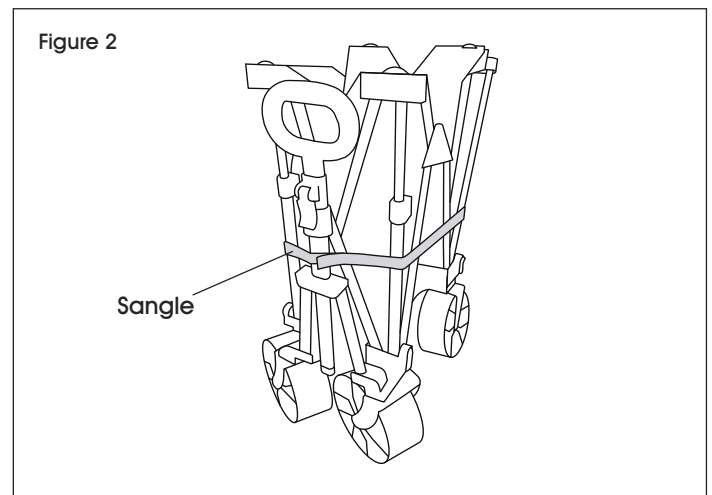

INSTRUCTIONS SUITE

3. Appuyez sur la partie centrale du niveau supérieur pour ouvrir le chariot. (Voir Figure 3)

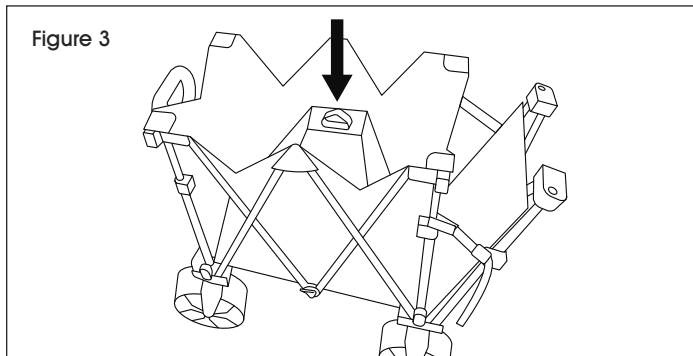

4. Saisissez et soulevez les deux boucles d'extrémité pour étirer et verrouiller les pieds en position déployée. (Voir Figure 4)

REMARQUE : Un déclic audible se fait entendre lorsque les boutons des pieds se verrouillent en position déployée.

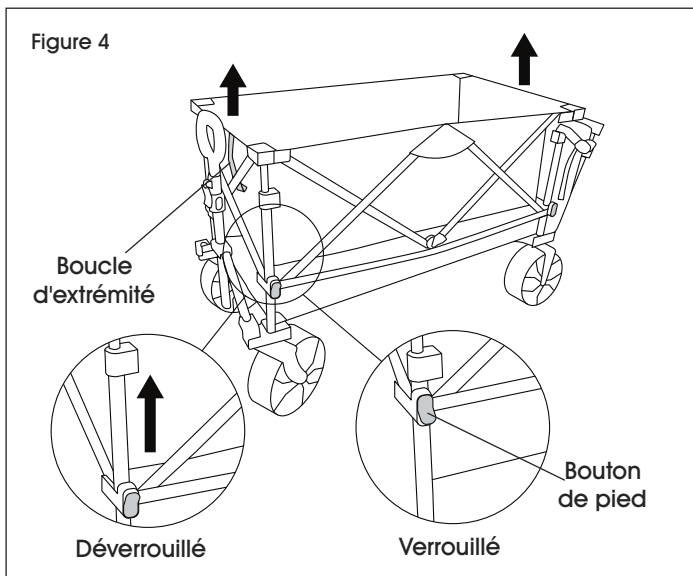

5. Dépliez et placez la plaque de base dans le haut du chariot pour un soutien supplémentaire. (Voir Figure 5)

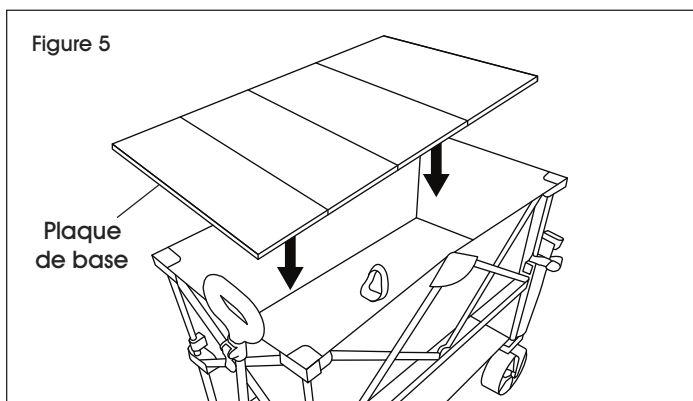

REMARQUE : Appuyez sur la partie centrale du niveau inférieur afin d'ouvrir complètement le chariot.

6. Tirez la poignée vers le haut pour verrouiller le bras de la poignée en place. Un déclic audible se fait entendre lorsque les languettes de la poignée se verrouillent en place. (Voir Figure 6)
7. Pour régler la poignée, soulevez le levier de verrouillage, allongez la poignée à la longueur souhaitée, puis poussez le levier de verrouillage vers le bas pour la bloquer. (Voir Figure 7)

REMARQUE : Ce réglage permet d'obtenir jusqu'à 15.2 cm (6 po) de longueur supplémentaire.

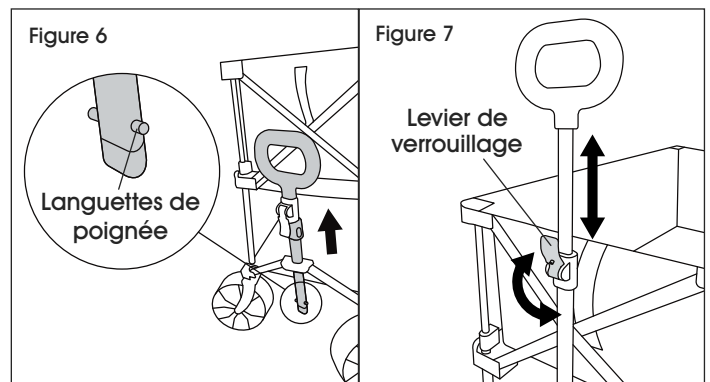

8. Avant l'utilisation, rentrez les sangles de la porte dans la poche de la porte. (Voir Figure 8)

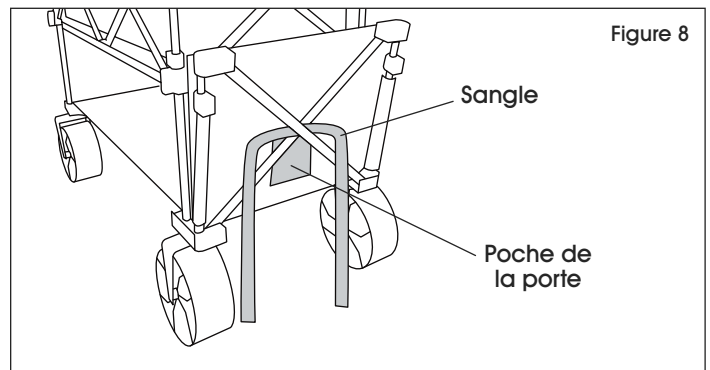

9. Ajustez les sangles de la porte pour lever et abaisser la porte du chariot. (Voir Figure 9)

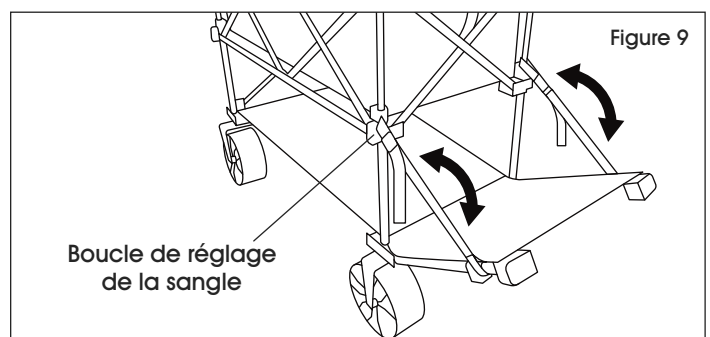

FIXATION DE LA TABLE

1. Connectez les supports de table. (Voir Figure 10)



IMPORTANT! Veillez à ce que les extrémités des supports soient orientées dans la même direction.

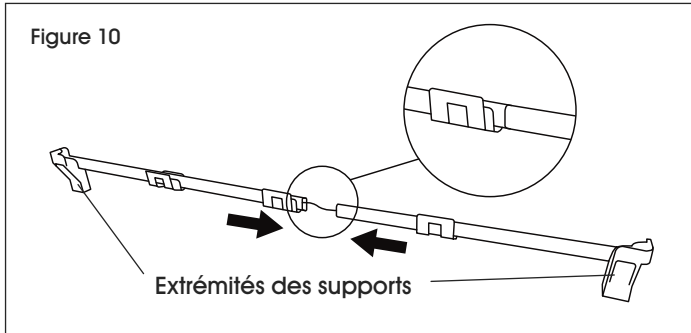

2. Faites glisser les supports de table connectés sur les coins extérieurs du cadre du chariot, les supports en L étant orientés vers le haut. (Voir Figure 11)

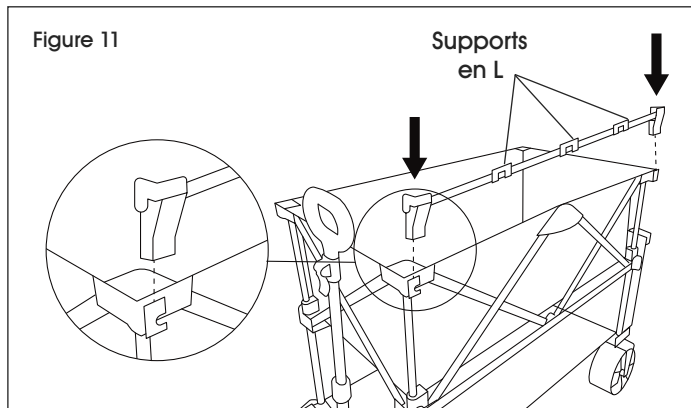

3. Déroulez et faites glisser la table dans les coins des supports de table. Les bords de la table doivent reposer à l'intérieur des supports en L. (Voir Figure 12)

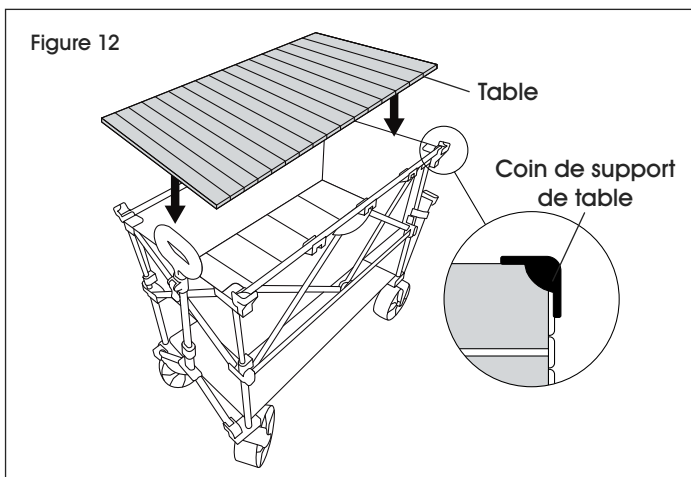

REPLIEMENT



IMPORTANT! Retirez la surface de table et les supports de table s'ils sont installés avant de procéder.

1. Retirez la plaque de base. (Voir Figure 13)

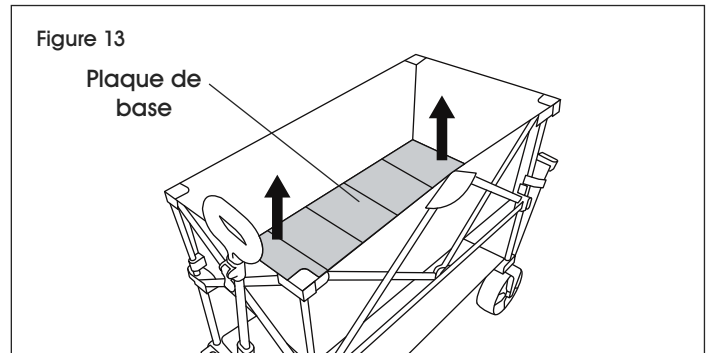

2. Appuyez sur le bouton du pied tout en poussant légèrement le coin supérieur vers le bas pour affaisser le chariot. Répétez l'opération pour les autres coins. (Voir Figure 14)

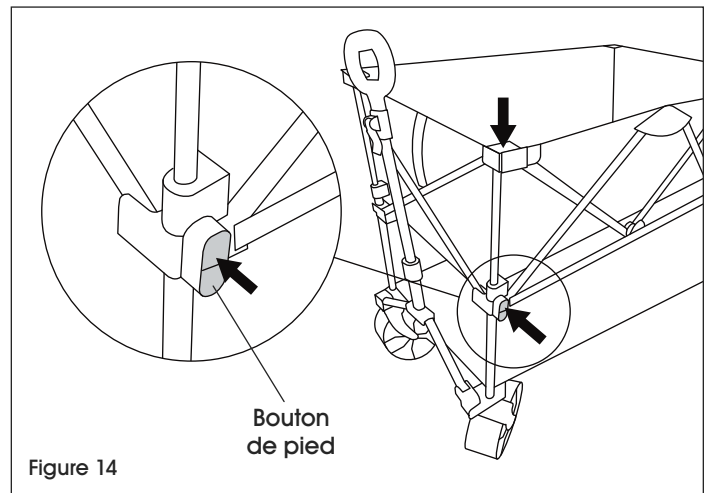

3. Raccourcissez la poignée à l'aide du levier de verrouillage. Appuyez sur les boutons de la poignée pour affaisser le bras de la poignée. (Voir Figures 15 et 16)

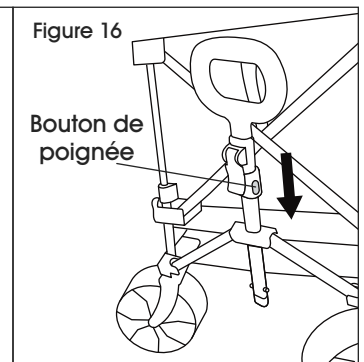
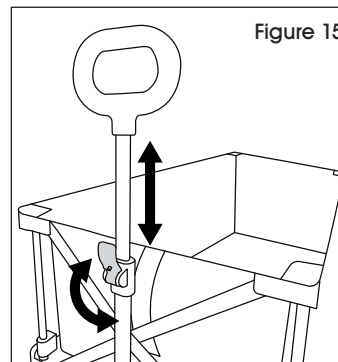

INSTRUCTIONS SUITE

4. Tirez sur la poignée au milieu du niveau supérieur du chariot pour l'affaisser. (Voir Figure 17)

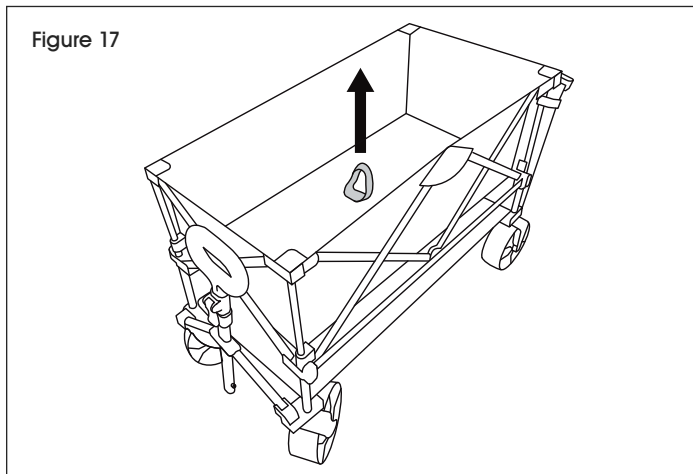

5. Fixez fermement la sangle autour du cadre. (Voir Figure 18)

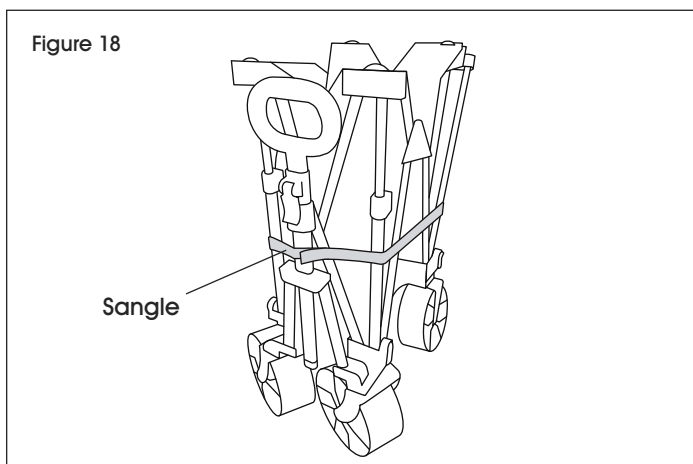

6. Placez la housse avec la fermeture à glissière ouverte par-dessus le chariot. Attachez les sangles à travers les boucles du cadre. (Voir Figure 19)

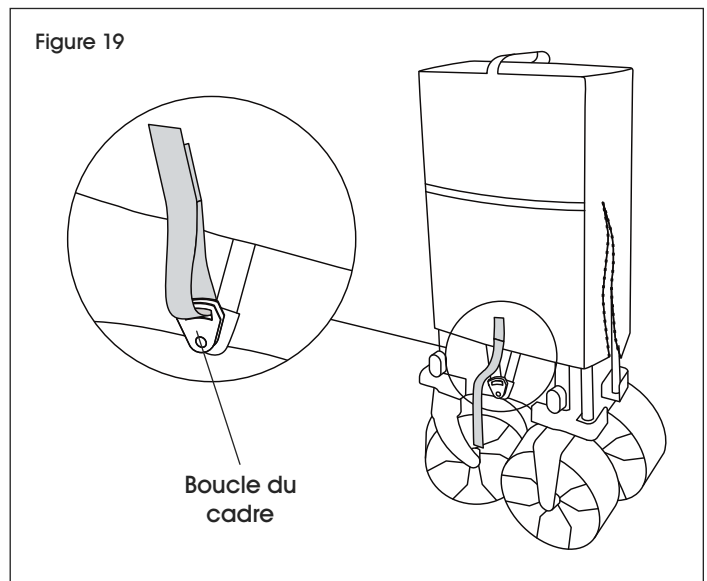

7. Fermez la housse à l'aide de la fermeture à glissière et placez la plaque de base pliée dans la pochette de la housse. (Voir Figure 20)

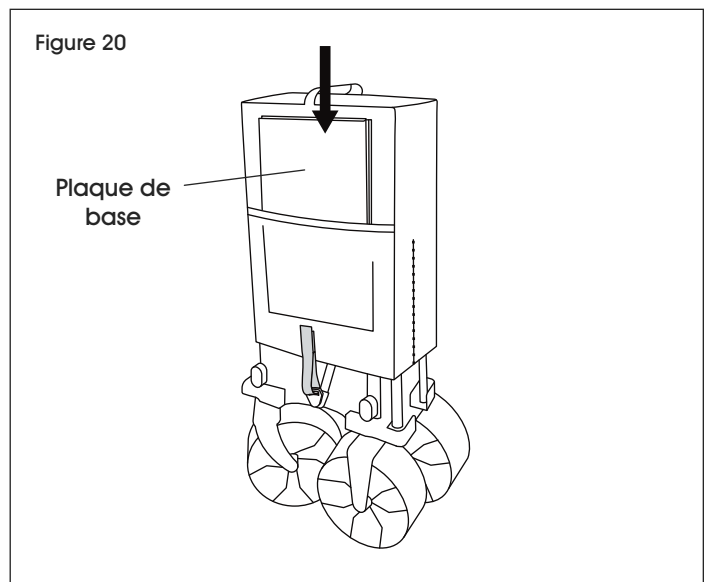

ULINE

1 800 295-5510
uline.ca