

ULINE S-8244 MAGAZINE FILE BOX

1-800-295-5510
uline.com

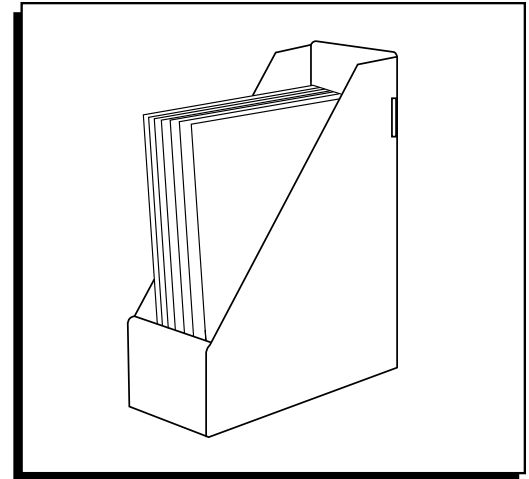

ASSEMBLY

1. Lay file box flat with kraft side facing up. Fold flaps A up on front end of box. (See Figure 1)

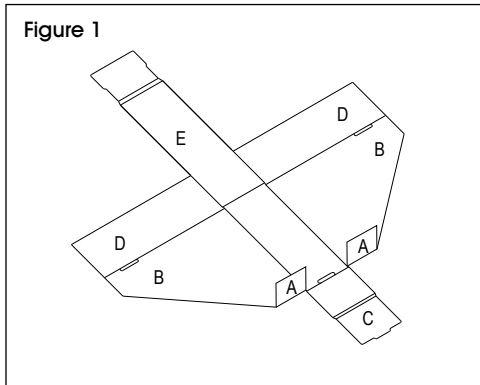

2. Fold flaps B up so they are perpendicular to the bottom and flaps A meet in the middle. (See Figure 2)

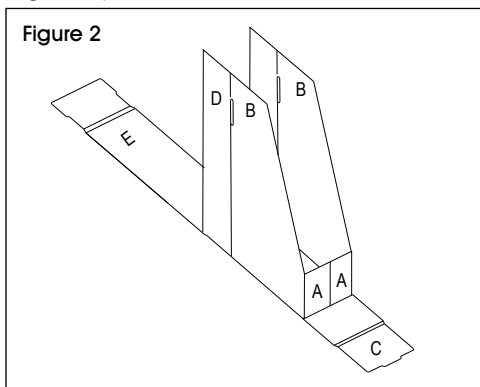

3. Fold flap C up and over flaps A, tucking into slot at the bottom. (See Figure 3)

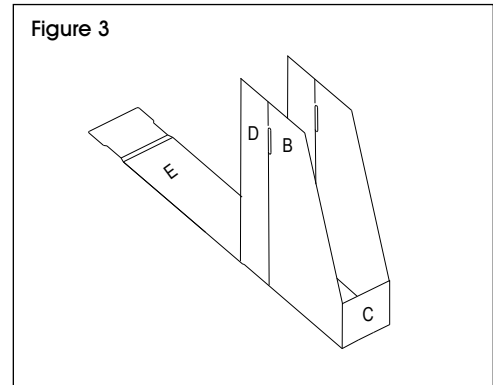

4. Fold flaps D at creases to form the back of the box. (See Figure 4)

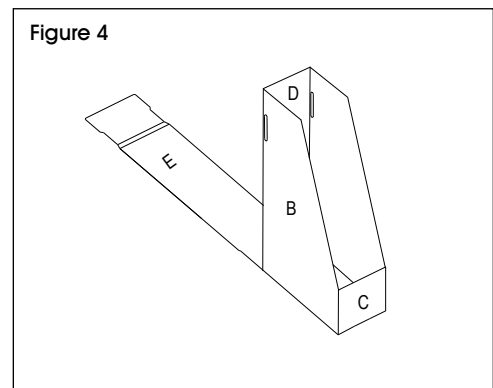

5. Fold flap E up and over back of box, tucking tabs into side slots. (See Figure 5)

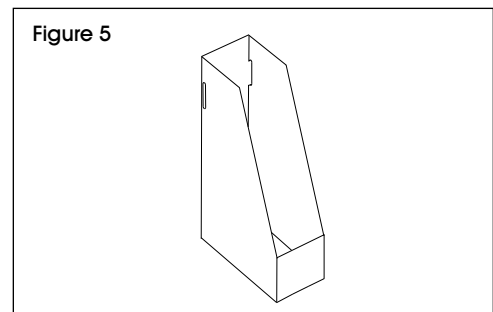

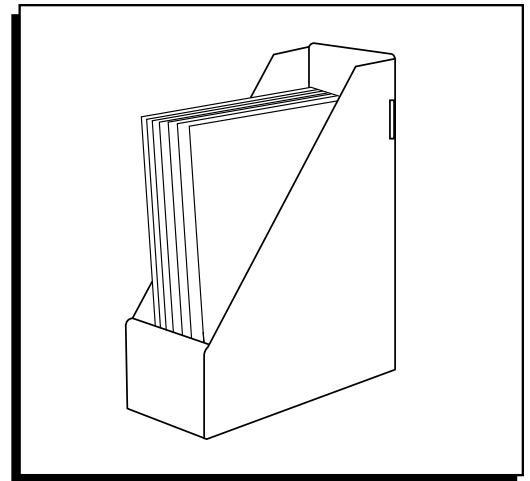
**ENSAMBLE**

1. Coloque la caja desarmada con el lado color kraft boca arriba. Doble las solapas A hacia arriba en el extremo frontal de la caja. (Vea Diagrama 1)

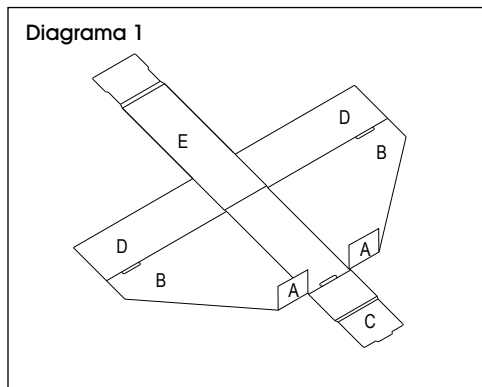

2. Doble las solapas B hacia arriba de manera que estén perpendiculares al fondo y coincidan con las solapas A en medio. (Vea Diagrama 2)

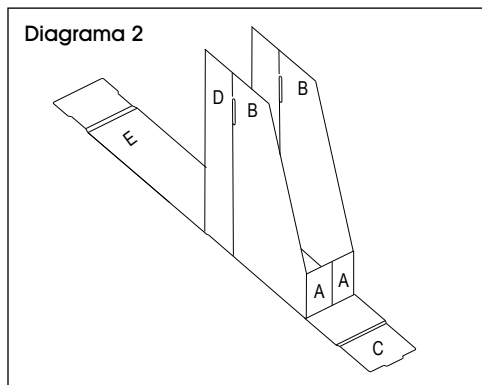

3. Doble la solapa C hacia arriba y sobre las solapas A, ajustando dentro de las ranuras al fondo. (Vea Diagrama 3)

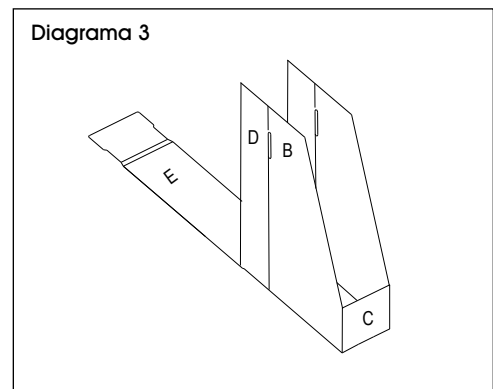

4. Doble las solapas D por las marcas para formar la parte posterior de la caja. (Vea Diagrama 4)

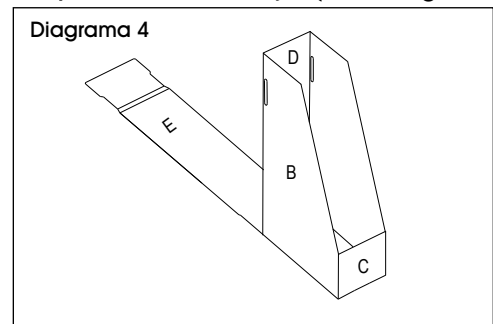

5. Doble la solapa E por la parte posterior y ajuste las solapas dentro de las ranuras laterales. (Vea Diagrama 5)

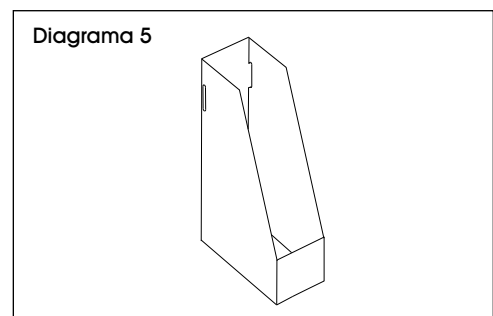

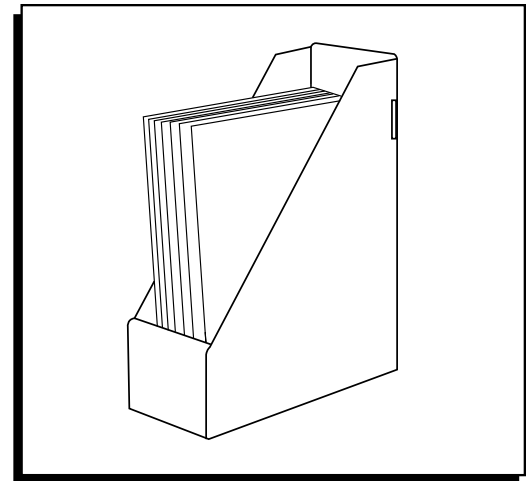

ASSEMBLAGE

1. Posez la boîte à plat, côté kraft vers le haut. Pliez les rabats A, situés sur l'extrémité avant de la boîte, vers le haut. (Voir Figure 1)

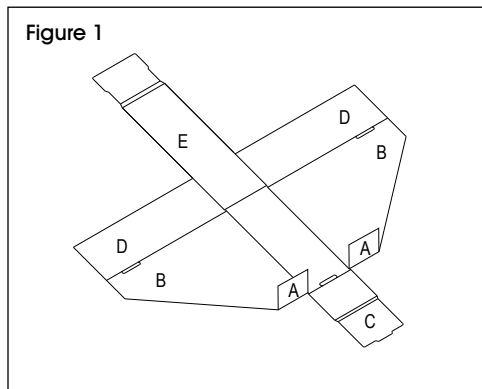

2. Pliez les rabats B vers le haut afin qu'ils soient perpendiculaires avec le fond de la boîte et que les rabats A se retrouvent au milieu. (Voir Figure 2)

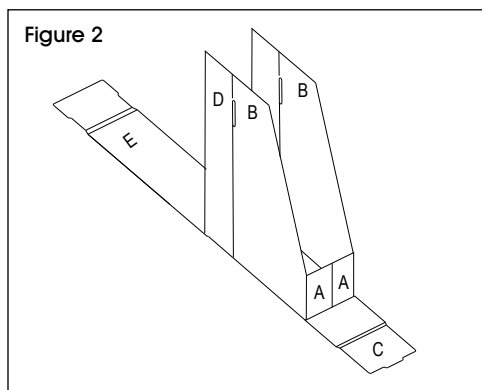

3. Pliez le rabat C vers le haut et par-dessus les rabats A en l'insérant dans les fentes se trouvant sur le fond. (Voir Figure 3)

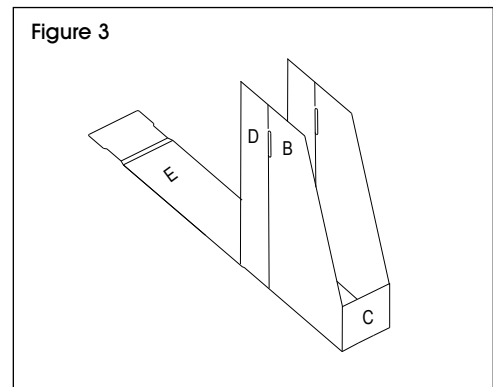

4. Pliez les rabats D au niveau des plis pour former la partie arrière de la boîte. (Voir Figure 4)

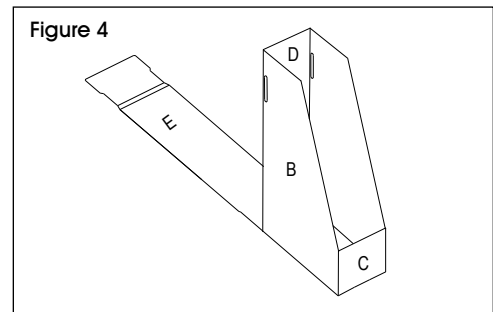

5. Pliez le rabat E vers le haut et par-dessus la partie arrière de la boîte en insérant les languettes dans les fentes latérales. (Voir Figure 5)

