

ULINE INDUSTRIAL COUNTING SCALES

H-1114, H-1115
H-1116, H-1117

1-800-295-5510
uline.com

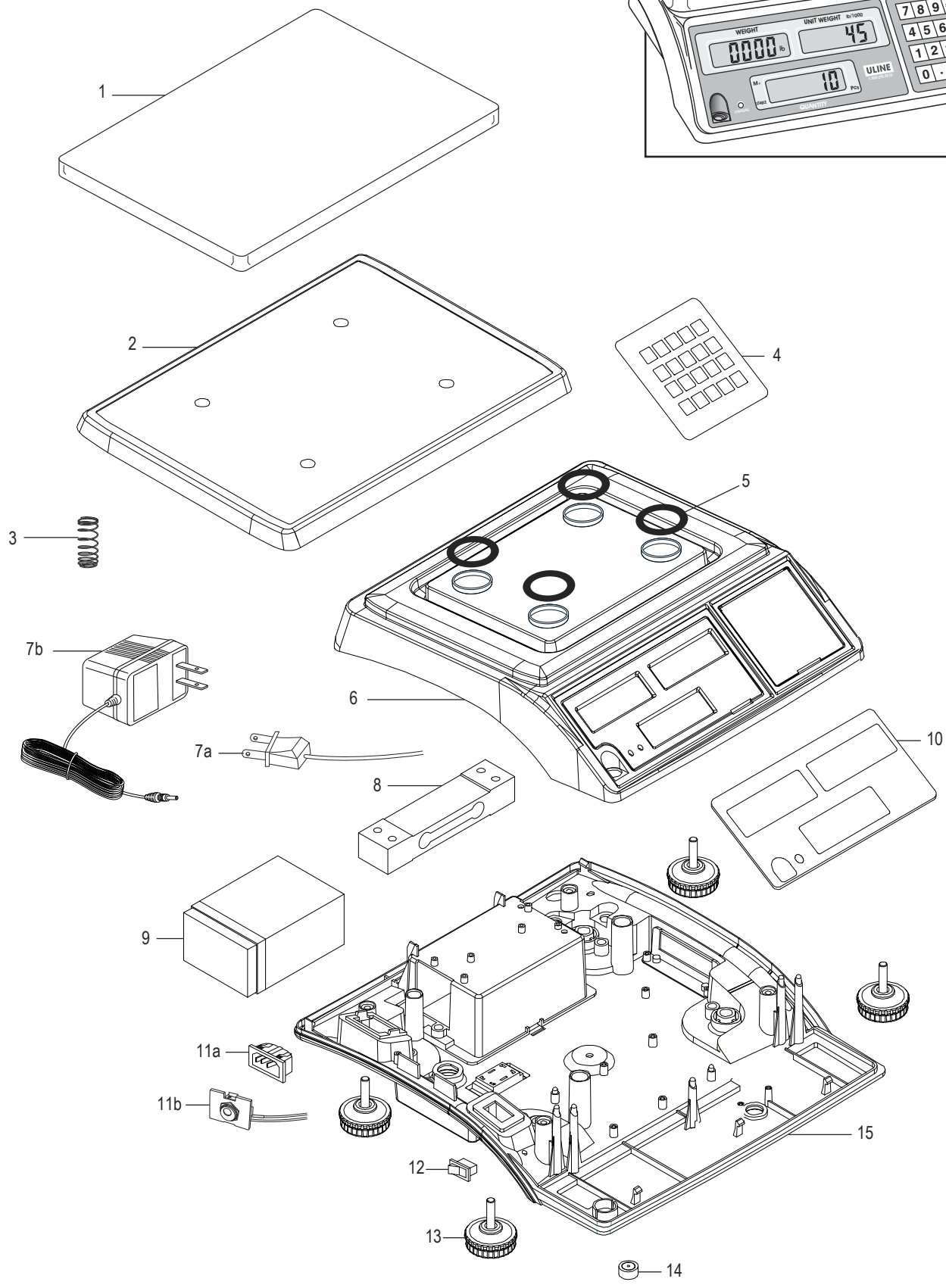

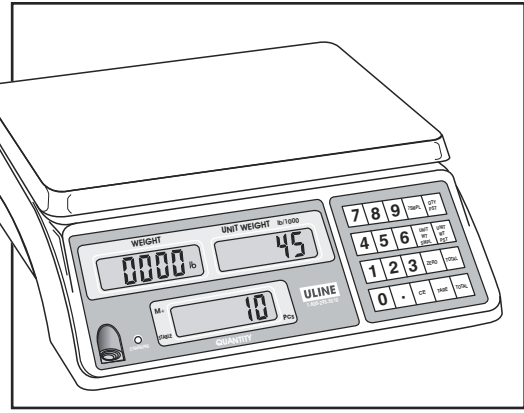

H-1114, H-1115
H-1116, H-1117

1-800-295-5510
uline.com

INDUSTRIAL COUNTING SCALES

#	DESCRIPTION	QTY.	ULINE PART NO.	MFG. PART NO.
1	Stainless Steel Weighing Pan	1	H-5250	ZPF1300000016
2	Plastic Weighing Pan	1	H-1117-PLATE	ZPF3300000004
3	Grounding Spring	1	H-1116-GSPR	ZSP0000000000
4	Keypad Overlay (Old Design)*	1	H-114-PAD	KB0200000001
4	Keypad Overlay (New Design)*	1	H-5249	ZKB0120000000+ ZKBX2200000000
5	Dust Ring	4	H-5376	ZPMC9000000002
6	Upper Housing	1	N/A	ZPMA100000104
7a	3-Plug Power Cord	1	H-1122PCORD	6103040300
7b	AC Adapter	1	H-4102	ZTA1200000102
8	Load Cell for H-1114	1	H-1114-LDCL	ZLC01S0006007
8	Load Cell for H-1115	1	H-1115-LDCL	ZLC01S0006003
8	Load Cell for H-1116	1	H-1116-LDCL	ZLC01S0006004
8	Load Cell for H-1117	1	H-1117-LDCL	ZLC01S0006005
9	Battery	1	H-1118	EPZU0A400000
10	Display Overlay for H-1114	1	H-1114-OVRLY	ZFPX220000019
10	Display Overlay for H-1115	1	H-1115-OVRLY	ZFPX220000020
10	Display Overlay for H-1116	1	H-1116-OVRLY	ZFPX220000021
10	Display Overlay for H-1117 (Old Design)*	1	H-1117-FRCVR	ZFPE2200000056
10	Display Overlay for H-1117 (New Design)*	1	H-1117-OVRLY	ZFPX2200000022
11a	3-Pin Power Socket	1	H-1117-PCS	ZCPFD03000000
11b	AC Adapter Power Socket Assembly	1	H-6016	ESC14Z000000
12	On/Off Power Switch	1	H-670-SWITCH	ZSW2000000011
13	Foot	4	H-1117-FOOT	ZNRA0000000021
14	Level Indicator	1	H-1117-LEVEL	ZPMH1000000001
15	Lower Housing	1	H-1117LWRHSG	ZPMA100000106
	Dust Cover (Not Shown)	1	H-5251	ZNRC0000000007
	Display Mainboard (Not Shown)	1	H-1117-MAIN	ZPC1603000059

* Display overlay and keypad color changed starting with serial #A13310331.

ULINE

H-1114, H-1115
H-1116, H-1117

BÁSCULA CONTADORA INDUSTRIAL

800-295-5510
uline.mx

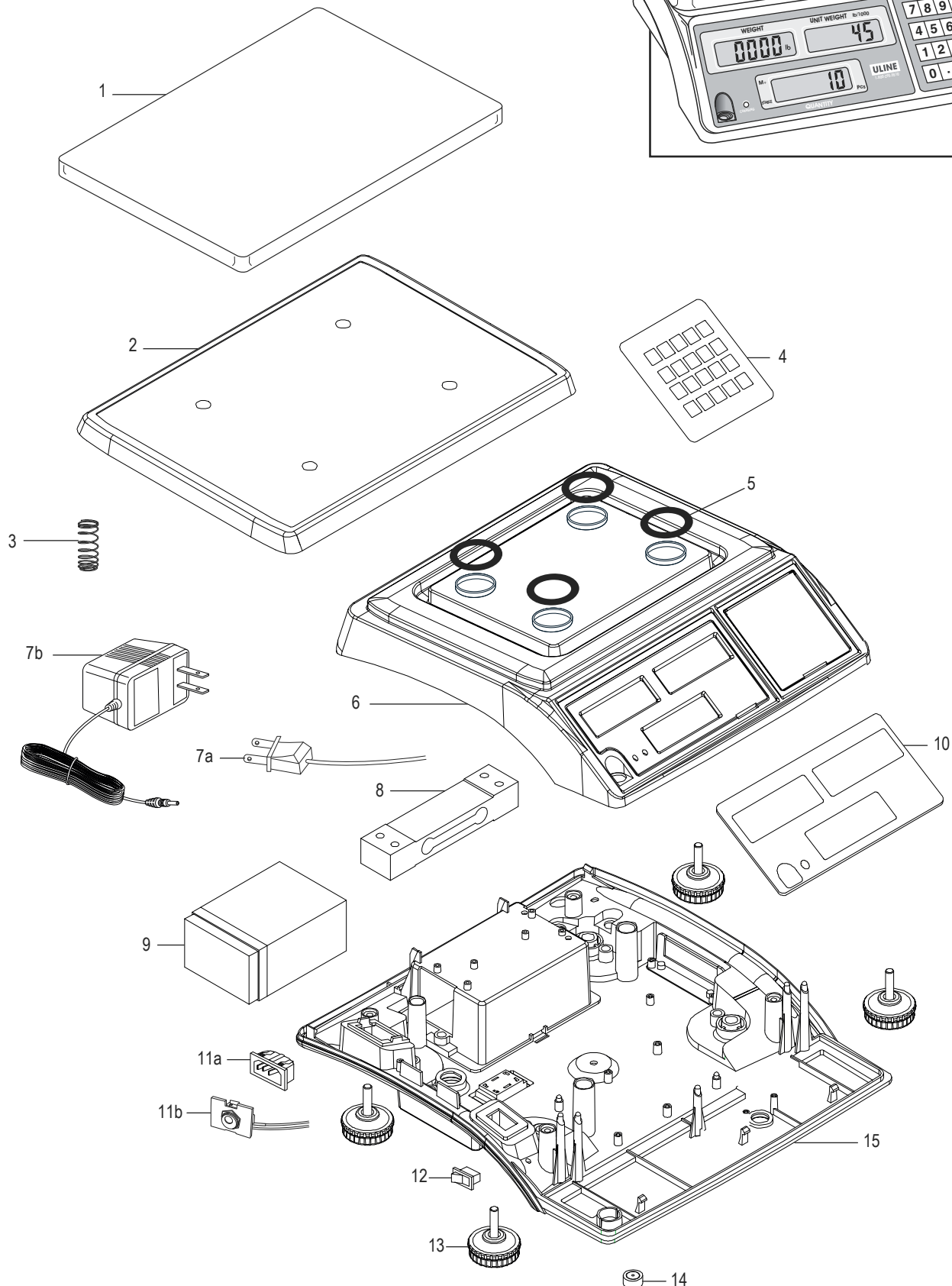
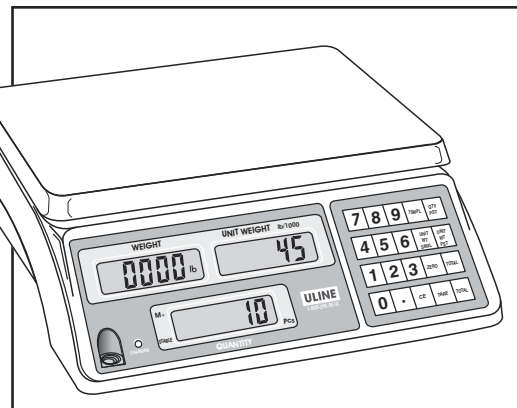



H-1114, H-1115
H-1116, H-1117

BÁSCULA CONTADORA INDUSTRIAL

800-295-5510
uline.mx

#	DESCRIPCIÓN	CANT.	NO. DE PARTE DE ULINE	NO. DE PARTE DEL FABRICANTE
1	Plataforma de Acero Inoxidable para Pesaje	1	H-5250	ZPF1300000016
2	Plataforma de Plástico para Pesaje	1	H-1117-PLATE	ZPF3300000004
3	Resorte para Hacer Tierra	1	H-1116-GSPR	ZSP0000000000
4	Mica del Teclado (Diseño Antigüo)*	1	H-114-PAD	KB0200000001
4	Mica del Teclado (Diseño Nuevo)*	1	H-5249	ZKB0120000000+ ZKBX2200000000
5	Anillo para Polvo	4	H-5376	ZPMC9000000002
6	Cubierta Superior	1	N/A	ZPMA100000104
7a	Enchufe de 3 Polos	1	H-1122PCORD	6103040300
7b	Adaptador CA	1	H-4102	ZTA1200000102
8	Celda de Carga para H-1114	1	H-1114-LDCL	ZLC01S0006007
8	Celda de Carga para H-1115	1	H-1115-LDCL	ZLC01S0006003
8	Celda de Carga para H-1116	1	H-1116-LDCL	ZLC01S0006004
8	Celda de Carga para H-1117	1	H-1117-LDCL	ZLC01S0006005
9	Batería	1	H-1118	EPZU0A400000
10	Mica de Pantalla para H-1114	1	H-1114-OVRLY	ZFPX220000019
10	Mica de Pantalla para H-1115	1	H-1115-OVRLY	ZFPX220000020
10	Mica de Pantalla para H-1116	1	H-1116-OVRLY	ZFPX220000021
10	Mica para Pantalla para H-1117 (Diseño Antigüo)*	1	H-1117-FRCVR	ZFPE220000056
10	Mica para Pantalla para H-1117 (Diseño Nuevo)*	1	H-1117-OVRLY	ZFPX220000022
11a	Enchufe de 3 Polos	1	H-1117-PCS	ZCPFD03000000
11b	Ensamble de la Entrada de Corriente del Adaptador CA	1	H-6016	ESC14Z000000
12	Interruptor de Encendido/Apagado	1	H-670-SWITCH	ZSW2000000011
13	Pata	4	H-1117-FOOT	ZNRA000000021
14	Indicador de Nivel	1	H-1117-LEVEL	ZPMH100000001
15	Cubierta Inferior	1	H-1117LWRHSG	ZPMA100000106
	Cubierta para Polvo (No se Muestra)	1	H-5251	ZNRC000000007
	Tarjeta Madre de Pantalla (No se Muestra)	1	H-1117-MAIN	ZPC1603000059

* Mica de pantalla y color de teclado cambiaron empezando con la serie #A13310331.

ULINE

H-1114, H-1115
H-1116, H-1117

**BALANCES COMPTEUSES
INDUSTRIELLES**

1 800 295-5510
uline.ca

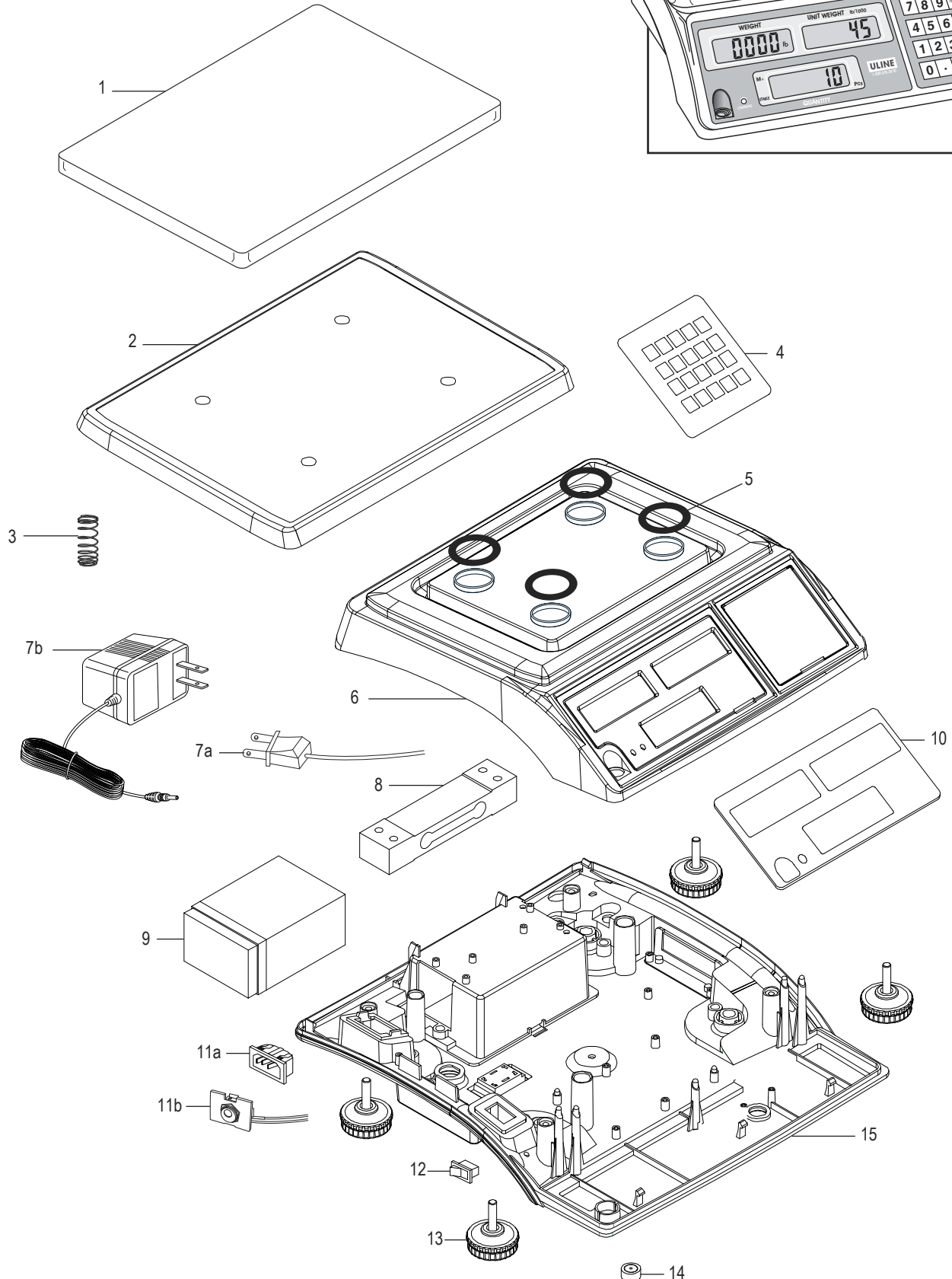
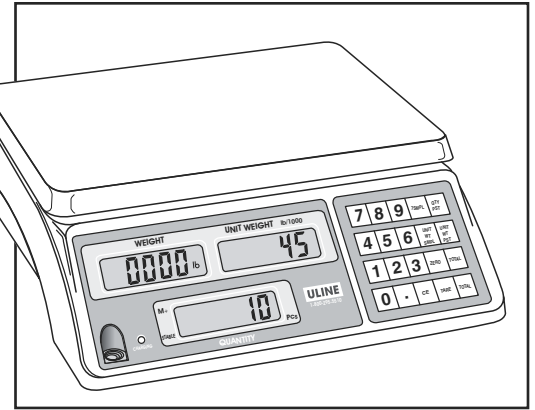



H-1114, H-1115
H-1116, H-1117

BALANCES COMPTEUSES INDUSTRIELLES

1 800 295-5510
uline.ca

#	DESCRIPTION	QTÉ	RÉF. ULINE	RÉF. DU FABRICANT
1	Plateau de pesage en acier inoxydable	1	H-5250	ZPF1300000016
2	Plateau de pesage en plastique	1	H-1117-PLATE	ZPF3300000004
3	Ressort de mise à la terre	1	H-1116-GSPR	ZSP0000000000
4	Revêtement de clavier (conception ancienne)*	1	H-114-PAD	KB0200000001
4	Revêtement de clavier (nouvelle conception)*	1	H-5249	ZKB0120000000+ ZKBX2200000000
5	Anneau de glissement	4	H-5376	ZPMC9000000002
6	Boîtier supérieur	1	N/A	ZPMA100000104
7a	Cordon d'alimentation à trois broches	1	H-1122PCORD	6103040300
7b	Adaptateur c.a.	1	H-4102	ZTA1200000102
8	Cellule de pesage pour H-1114	1	H-1114-LDCL	ZLC01S0006007
8	Cellule de pesage pour H-1115	1	H-1115-LDCL	ZLC01S0006003
8	Cellule de pesage pour H-1116	1	H-1116-LDCL	ZLC01S0006004
8	Cellule de pesage pour H-1117	1	H-1117-LDCL	ZLC01S0006005
9	Batterie	1	H-1118	EPZU0A400000
10	Revêtement d'écran pour H-1114	1	H-1114-OVRLY	ZFPX220000019
10	Revêtement d'écran pour H-1115	1	H-1115-OVRLY	ZFPX220000020
10	Revêtement d'écran pour H-1116	1	H-1116-OVRLY	ZFPX220000021
10	Revêtement d'écran pour H-1117 (conception ancienne)*	1	H-1117-FRCVR	ZFPE2200000056
10	Revêtement d'écran pour H-1117 (nouvelle conception)*	1	H-1117-OVRLY	ZFPX2200000022
11a	Prise femelle pour fiche à 3 broches	1	H-1117-PCS	ZCPFD03000000
11b	Prise femelle pour adaptateur c.a.	1	H-6016	ESC14Z0000000
12	Interrupteur marche/arrêt	1	H-670-SWITCH	ZSW2000000011
13	Pied	4	H-1117-FOOT	ZNRA0000000021
14	Indicateur de niveau	1	H-1117-LEVEL	ZPMH1000000001
15	Boîtier inférieur	1	H-1117LWRHSG	ZPMA100000106
	Couvercle antipoussière (non illustré)	1	H-5251	ZNRC0000000007
	Carte mère de l'écran (non illustrée)	1	H-1117-MAIN	ZPC1603000059

* La couleur du revêtement d'écran et du clavier a changé avec le numéro de série A13310331.