

ULINE H-1819

HYDRAULIC PLATFORM STACKER

1-800-295-5510
 uline.com

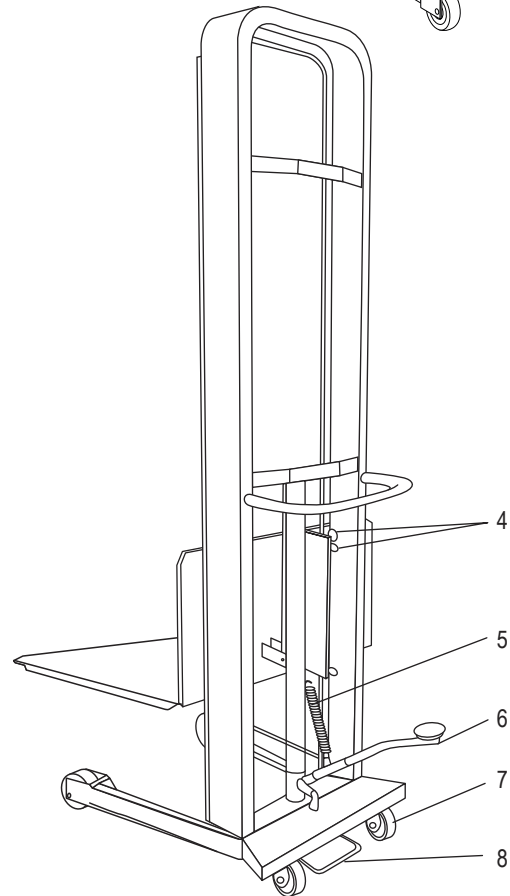
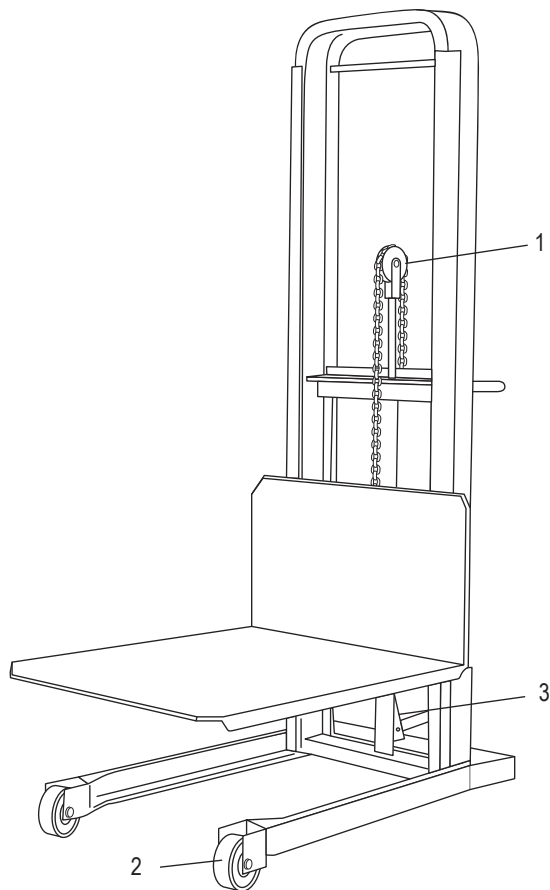
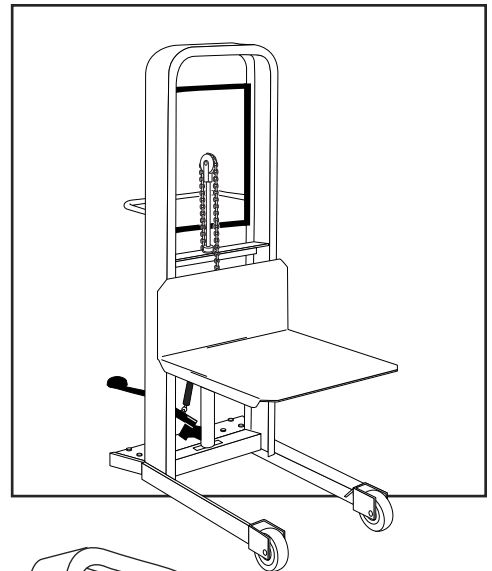

#	DESCRIPTION	QTY.	ULINE PART NO.	MFG. PART NO.
1	Chain Roller Assembly	1	H-1819-CHAIN	0584-VR
2	Rigid Phenolic Wheel	2	H-1819-RIGID	C102PH
3	Cylinder Assembly	1	H-1819-M400	M400-52
4	Roller Kit	4	-----	C107
5	Return Spring	1	H-1819-M429	M429
6	Foot Lever (pad M437)	1	H-1819-M436	M436
7	Swivel Wheel Assembly	2	H-1819-SWIVE	C101PH2
8	Floor Lock	1	-----	C100

ULINE H-1819
ESTIBADOR HIDRÁULICO

800-295-5510
 uline.mx

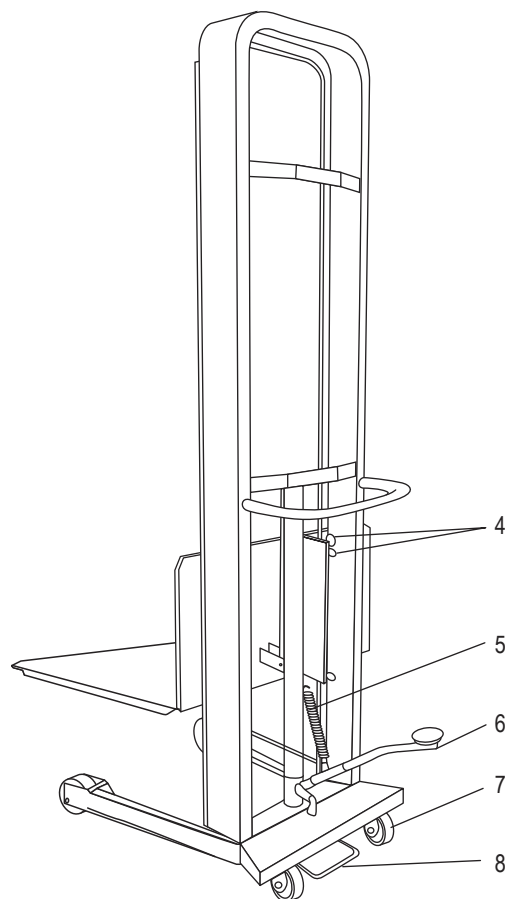
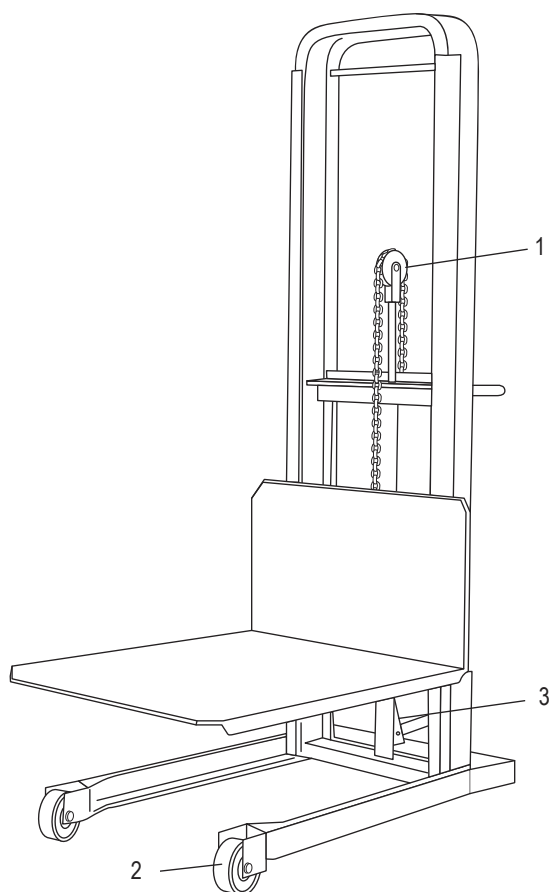
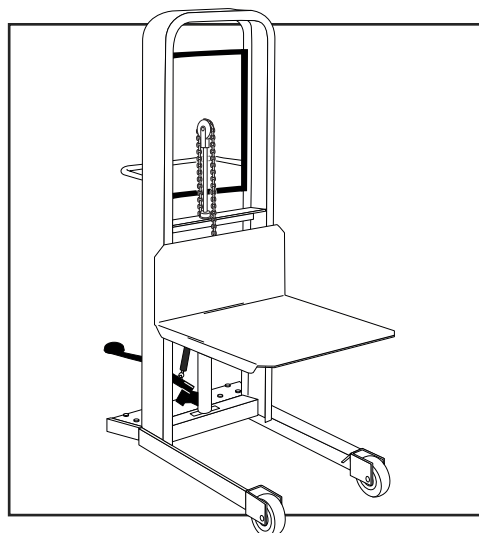

#	DESCRIPCIÓN	CANT.	NO. DE PARTE DE ULINE	NO. DE PARTE DEL FABRICANTE
1	Ensamble del Rodillo de Cadena	1	H-1819-CHAIN	0584-VR
2	Llanta Fenólica Rígida	2	H-1819-RIGID	C102PH
3	Ensamble del Cilindro	1	H-1819-M400	M400-52
4	Kit del Rodillo	4	-----	C107
5	Resorte de Regreso	1	H-1819-M429	M429
6	Palanca de Pie (pad M437)	1	H-1819-M436	M436
7	Ensamble de la Llanta Giratoria	2	H-1819-SWIVE	C101PH2
8	Seguro de Piso	1	-----	C100

ULINE H-1819
GERBEUR HYDRAULIQUE
À PLATEFORME

1 800 295-5510
 uline.ca

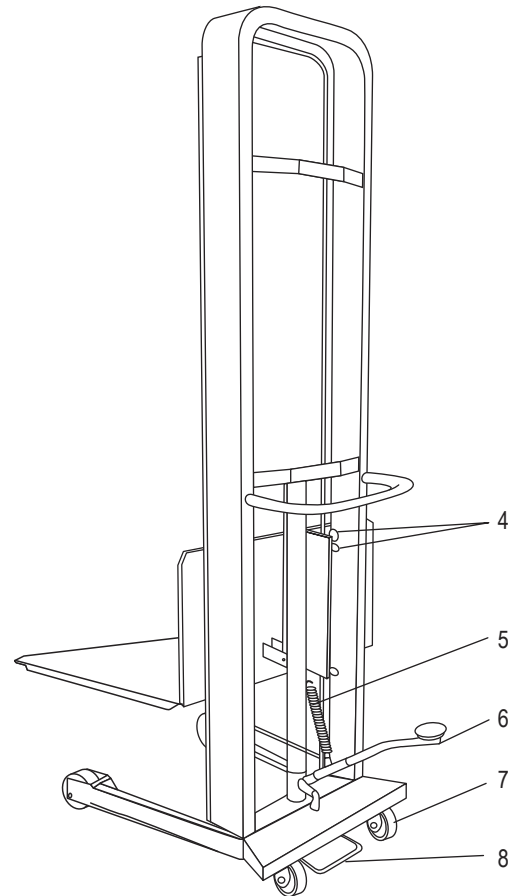
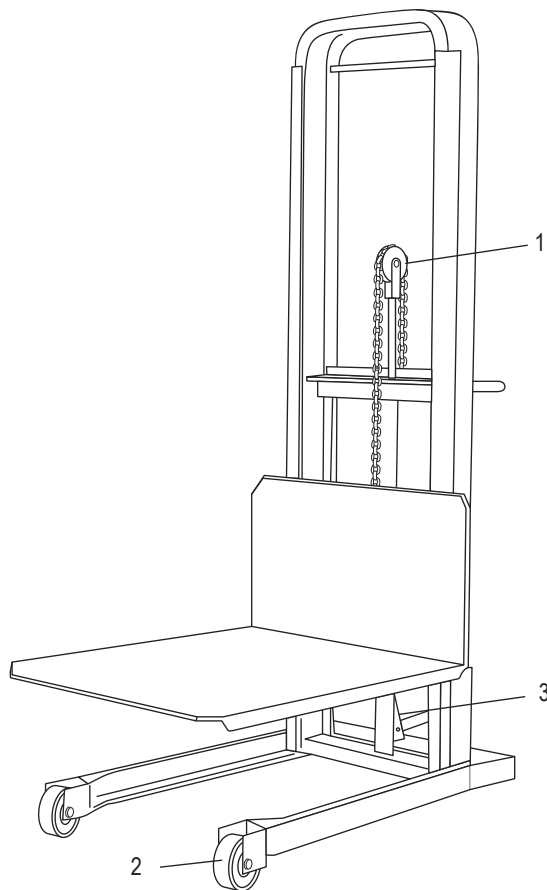
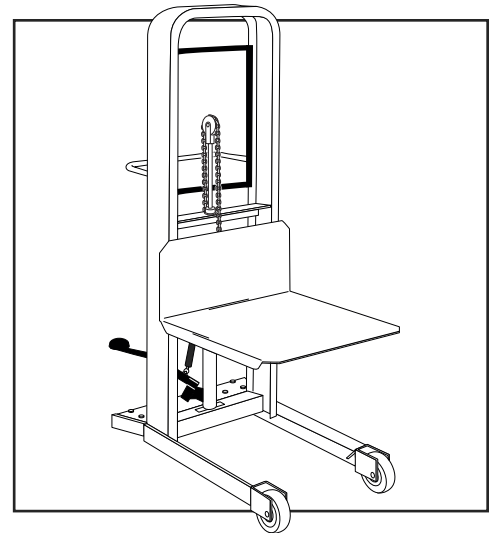

#	DESCRIPTION	QTÉ	RÉF. ULINE	RÉF. DU FABRICANT
1	Rouleau de chaîne	1	H-1819-CHAIN	0584-VR
2	Roue phénolique rigide	2	H-1819-RIGID	C102PH
3	Cylindre	1	H-1819-M400	M400-52
4	Ensemble de rouleaux	4	-----	C107
5	Ressort de rappel	1	H-1819-M429	M429
6	Levier à pied (tampon M437)	1	H-1819-M436	M436
7	Roue pivotante	2	H-1819-SWIVE	C101PH2
8	Verrou de plancher	1	-----	C100