

# ULINE H-2722 ALL-TERRAIN PALLET TRUCK

1-800-295-5510  
uline.com

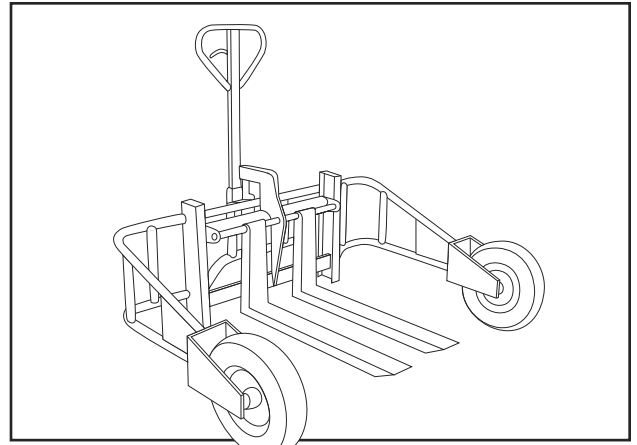

## FRAME DIAGRAM

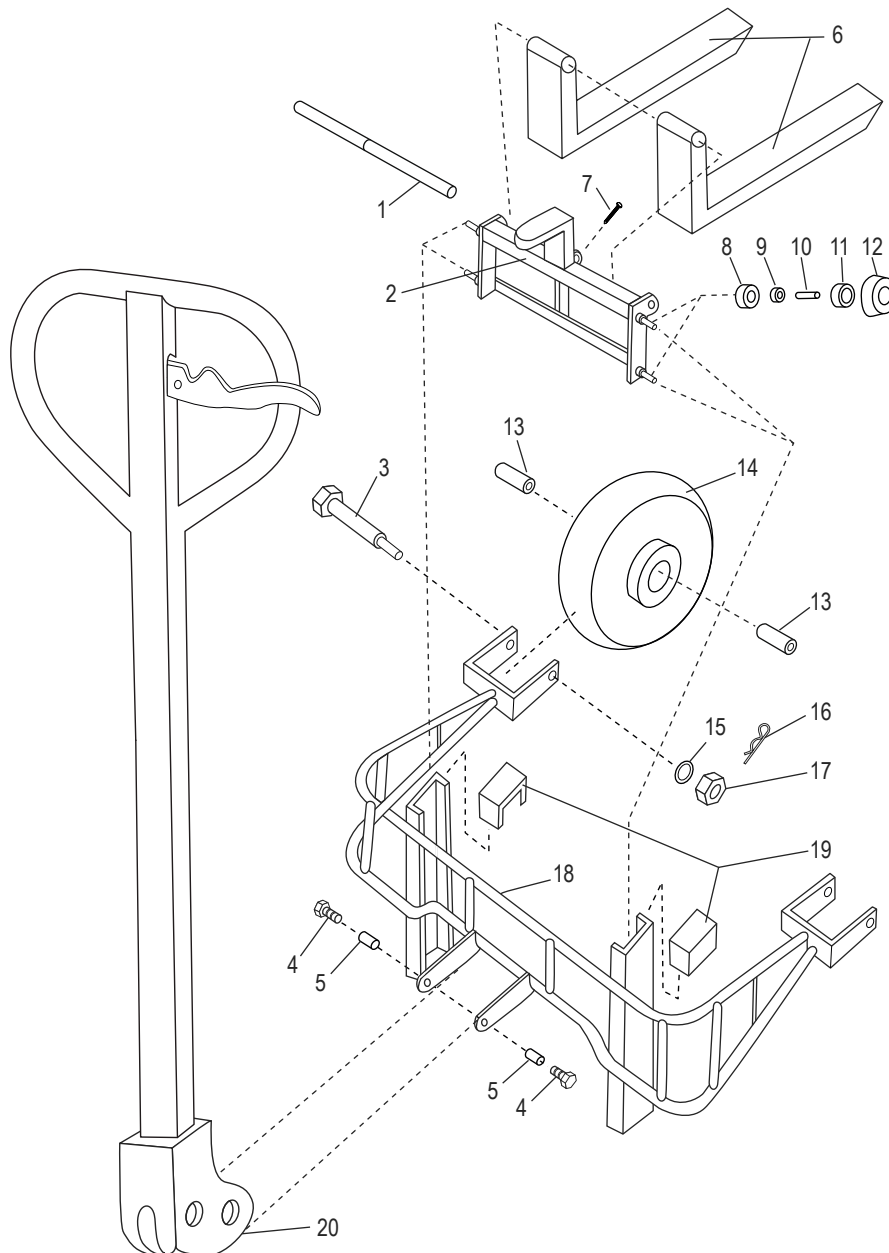

## FRAME DIAGRAM PARTS LIST

#	DESCRIPTION	QTY.	ULINE PART NO.	MFG. PART NO.
1	Shaft	1	-----	PM-ALT-54
2	Mounting Plate	1	H-2722-PLATE	PM-ALT-55
3	Shaft	2	H-2722-SHAFT	PM-ALT-56
4	Table Pin	2	-----	PM-ALT-44
5	Bushing 1620	2	-----	PM-ALT-45
6	Fork	2	-----	PM-ALT-57
7	Screw M6 x35	1	-----	PM-ALT-58
8	Guide Roller	4	-----	PM-ALT-59
9	Bushing 0808	4	-----	PM-ALT-60
10	Guide Roller Axis	4	-----	PM-ALT-61
11	Bearing 6206-Z	4	-----	PM-ALT-62
12	Rolling Axle Cover	4	-----	PM-ALT-63
13	Washer	4	H-2722-WASH	PM-ALT-64
14	Front Wheel	2	H-2722-WHEEL	PM-ALT-65
15	Washer 16	2	H-2722-W16	40361
16	Split Pin 4x30	2	H-2722-SPIN	0162010
17	Nut M16	2	H-2722-NUT	PM-ALT-52
18	Master Frame	1	-----	PM-ALT-67
19	Dust Cover	2	-----	PM-ALT-68
20	Handle Complete Assembly	1	H-2722-HANDL	ALL-T-2-14-HCA

**HANDLE DIAGRAM**

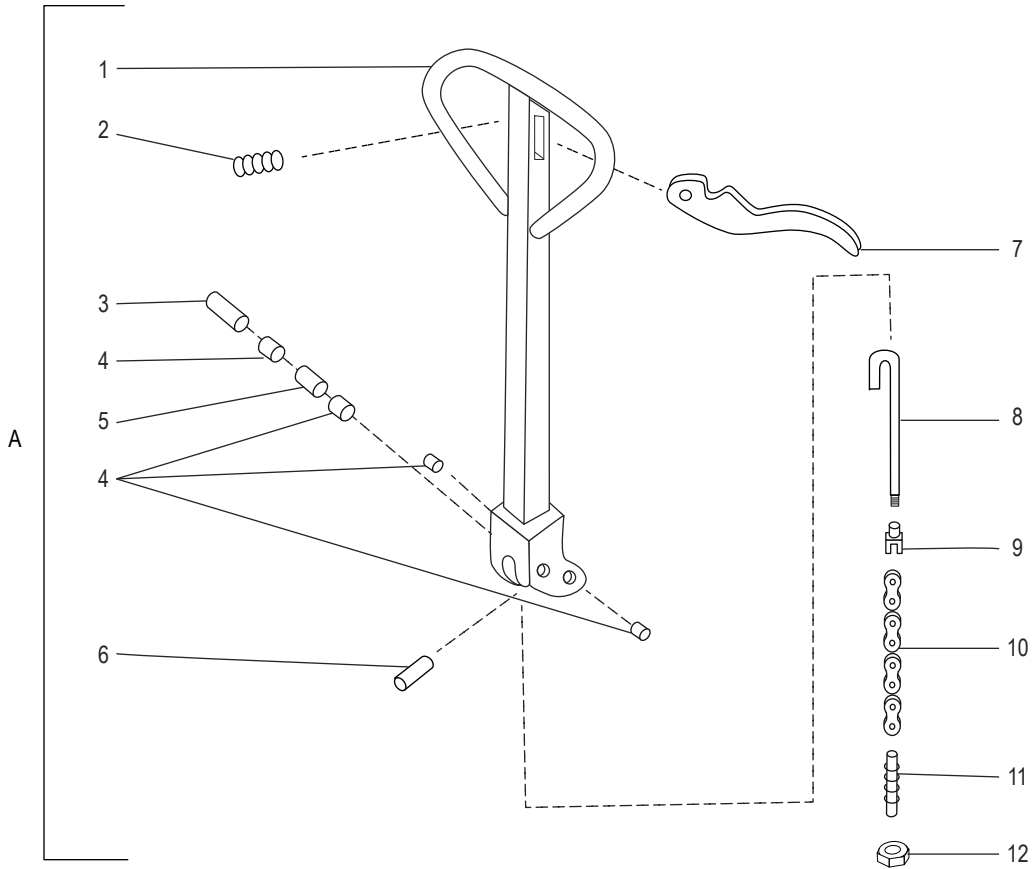

**HANDLE DIAGRAM PARTS LIST**

#	DESCRIPTION	QTY.	ULINE PART NO.	MFG. PART NO.
A	Handle Assembly	1	H-2722-HANDL	ALL-T-2-14-HCA
1	Handle	1	-----	PM-ALT-1
2	Spring	1	-----	PM-ALT-2
3	Roller Pin	1	-----	PM-ALT-3
4	Bushing 1615	4	-----	PM-ALT-4
5	Roller	1	-----	PM-ALT-5
6	Spring Pin 3x28	1	H-2722-40535	40535
7	Lever	1	-----	PM-ALT-30
8	Release Rod	1	-----	PM-ALT-31
9	Chain Joint	1	H-2722-ALT32	PM-ALT-32
10	Chain	1	H-2722-ALT33	PM-ALT-33
11	Anchor Bolt	1	-----	PM-ALT-34
12	V-Nut M6	1	H-2722-VNUT	PM-ALT-35

**PUMP DIAGRAM**

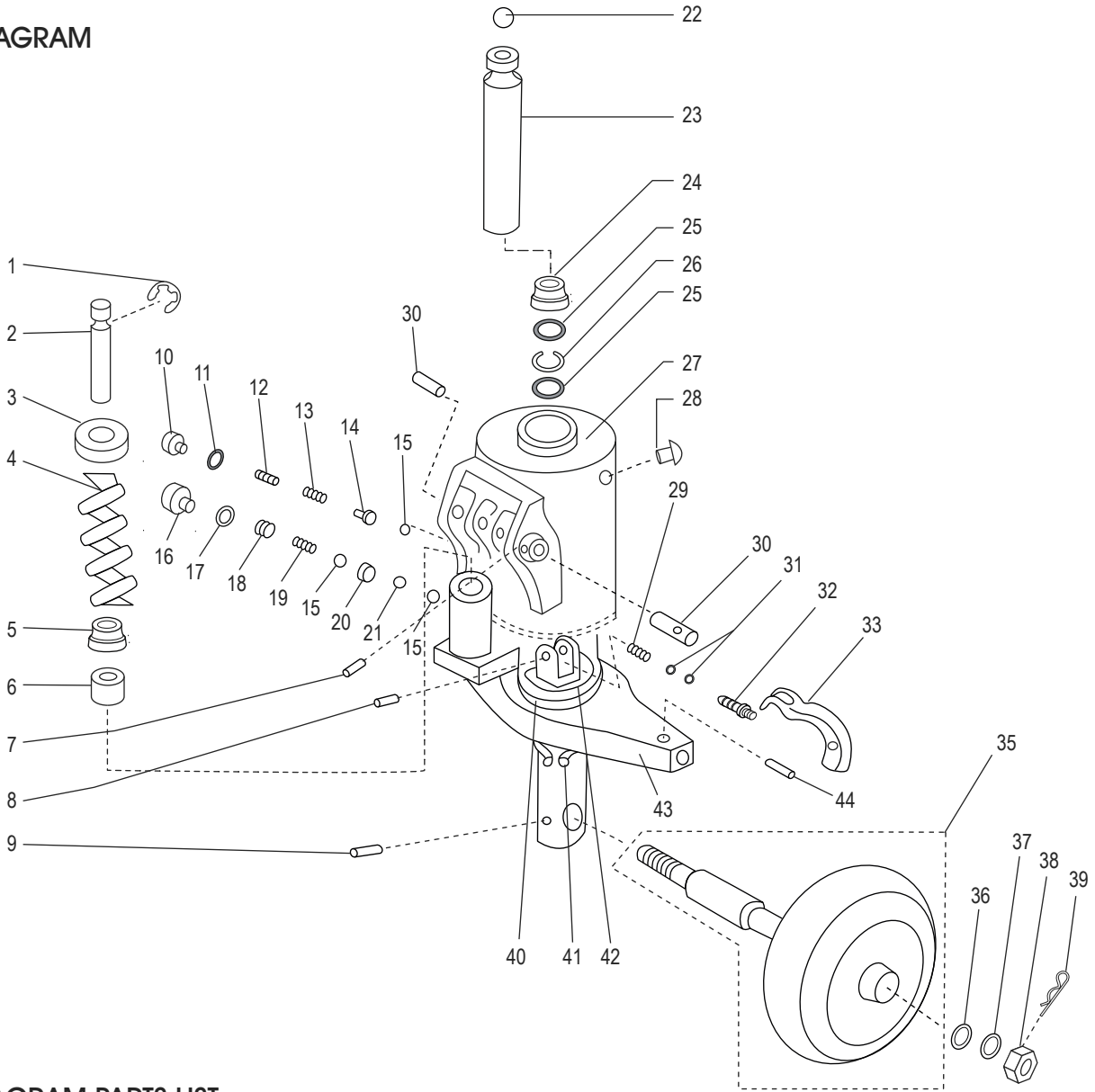

**PUMP DIAGRAM PARTS LIST**

#	DESCRIPTION	QTY.	ULINE PART NO.	MFG. PART NO.
1	E-Ring 15	1	H-2722-ERING	PM-ALT-9
2	Plunger Piston	1	-----	PM-ALT-10
3	Spring Cap	1	H-2722-CAP	PM-ALT-11
4	Spring	1	-----	PM-ALT-12
5	Dust Seal*	1	-----	PM-ALT-13
6	U-Ring 18x24x8	1	-----	PM-ALT-14
7	Spring Pin 3x28	1	H-2722-40535	40535
8	Spring Pin 8x25	1	-----	PM-ALT-16
9	Spring Pin 8x45	1	-----	PM-ALT-17

**ALL-TERRAIN  
PALLET TRUCK****PUMP DIAGRAM PARTS LIST CONTINUED**

#	DESCRIPTION	QTY.	ULINE PART NO.	MFG. PART NO.
10	Relief Plug	1	-----	PM-ALT-18
11	O-Ring 11.2x2.4	1	-----	PM-ALT-19
12	Pressure Adjust Screw	1	-----	PM-ALT-20
13	Spring	1	-----	PM-ALT-21
14	Spring Base	1	-----	PM-ALT-22
15	Steel Ball 6	3	-----	PM-ALT-23
16	Release Plug	1	-----	PM-ALT-24
17	Washer	1	-----	PM-ALT-25
18	Spring	1	-----	PM-ALT-26
19	Spring	1	-----	PM-ALT-27
20	Valve	1	-----	PM-ALT-28
21	Steel Ball 9	1	-----	PM-ALT-29
22	Steel Ball 14	1	H-2722-SB14	PM-ALT-36
23	Ram Piston	1	-----	PM-ALT-37
24	Dust Seal*	1	-----	PM-ALT-38
25	O-Ring 29.85x3.5*	2	-----	PM-ALT-39
26	Back-Up Ring*	1	-----	PM-ALT-40
27	Pump Housing Assembly	1	-----	PM-ALT-41
28	Oil Plug	1	H-2722-P28Q	PM-ALT-42
29	Spring	1	-----	PM-ALT-43
30	Handle Pin	2	H-2722-HNDLE	PM-ALT-8
31	O-Ring 4.8x1.9	2	H-2722-31	PM-ALT-46
32	Release Nozzle	1	-----	PM-ALT-47
33	Cam	1	-----	PM-ALT-48
35	<b>Back Wheel Kit</b> Includes: • Wheel (2) • Shaft (1)	1	H-2722-BWK	74-007-962
36	Bearing Seal	2	-----	PM-ALT-72
37	Washer 16	2	-----	PM-ALT-51
38	Nut M16	2	H-2722-NUT	PM-ALT-52
39	Split Pin 4x30	2	-----	PM-ALT-53
40	Bearing 51109-Z	1	H-2722-ALT70	PM-ALT-70
41	Snap Ring 44	1	H-2722-SRING	PM-ALT-66
42	Bearing Base	1	-----	PM-ALT-69
43	Table	1	-----	PM-ALT-71
44	Spring Pin	2	-----	-----

## PUMP DIAGRAM PARTS LIST CONTINUED

#	DESCRIPTION	QTY.	ULINE PART NO.	MFG. PART NO.
	<b>*Seal Kit (Not Shown)</b> Includes: <ul style="list-style-type: none"><li>• Large Wiper Seal (1)</li><li>• Large U-Cup Seal (1)</li><li>• Small Wiper Seal (1)</li><li>• Small U-Cup Seal (1)</li><li>• 35.5 x 3 O-Ring (1)</li><li>• 17 x 2.6 O-Ring (1)</li><li>• 10.5 x 2.6 Oil Seal (1)</li><li>• 8.44 x 1.8 O-Ring (2)</li></ul>	1	H-2722-KIT	-----
	Pump Assembly (Not Shown)	1	H-2722-PUMP	PM-ALT-PCA

**ULINE H-2722**  
**PATÍN HIDRÁULICO**  
**TODOTERRENO**

800-295-5510  
uline.mx



DIAGRAMA DEL ARMAZÓN



**ULINE H-2722**  
**PATÍN HIDRÁULICO**  
**TODOTERRENO**

800-295-5510  
 uline.mx

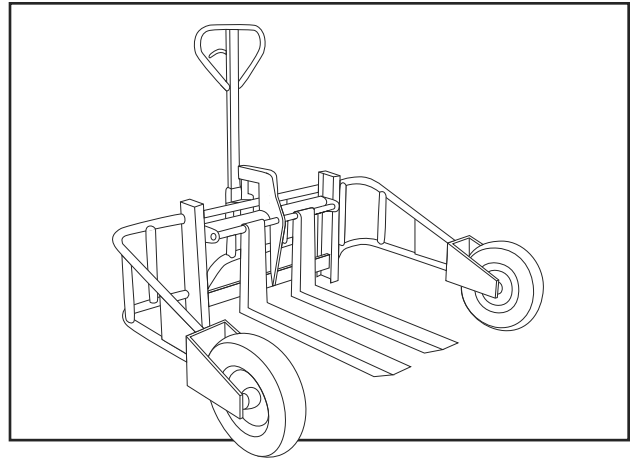
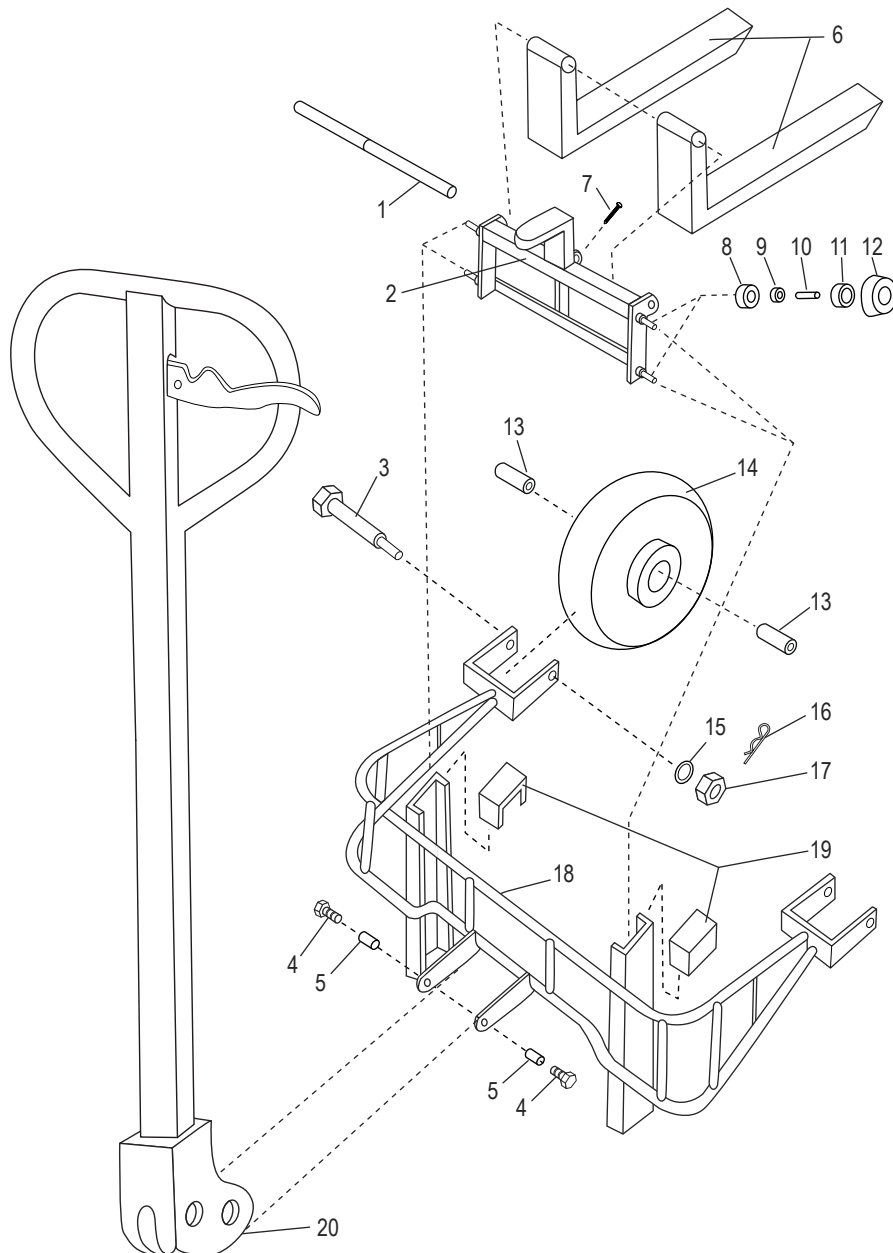
LISTA DE PARTES DEL DIAGRAMA DEL ARMAZÓN

#	DESCRIPCIÓN	CANT.	NO. DE PARTE DE ULINE	NO. DE PARTE DEL FABRICANTE
1	Eje	1	-----	PM-ALT-54
2	Placa de Montaje	1	H-2722-PLATE	PM-ALT-55
3	Eje	2	H-2722-SHAFT	PM-ALT-56
4	Pasador de Mesa	2	-----	PM-ALT-44
5	Buje 1620	2	-----	PM-ALT-45
6	Horquilla	2	-----	PM-ALT-57
7	Tornillo M6 x35	1	-----	PM-ALT-58
8	Rodillo Guía	4	-----	PM-ALT-59
9	Buje 0808	4	-----	PM-ALT-60
10	Eje del Rodillo Guía	4	-----	PM-ALT-61
11	Cojinete 6206-Z	4	-----	PM-ALT-62
12	Cubierta del Eje con Ruedas	4	-----	PM-ALT-63
13	Rondana	4	H-2722-WASH	PM-ALT-64
14	Llanta Delantera	2	H-2722-WHEEL	PM-ALT-65
15	Rondana 16	2	H-2722-W16	40361
16	Pasador Partido de 4x30	2	H-2722-SPIN	0162010
17	Tuerca M16	2	H-2722-NUT	PM-ALT-52
18	Armazón Principal	1	-----	PM-ALT-67
19	Cubierta para Polvo	2	-----	PM-ALT-68
20	Ensamble Completo del Asa	1	H-2722-HANDL	ALL-T-2-14-HCA



# ULINE H-2722

## PATÍN HIDRÁULICO

### TODOTERRENO

800-295-5510  
uline.mx

#### DIAGRAMA DEL ASA

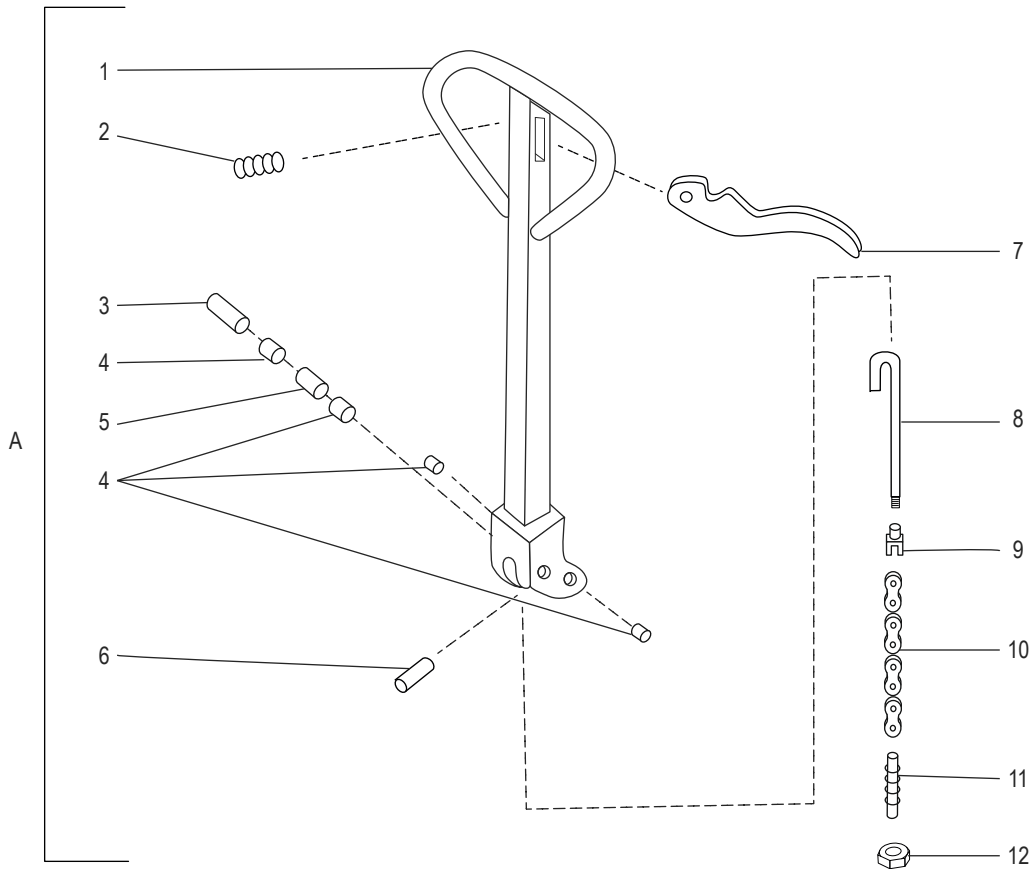

#### LISTA DE PARTES DEL DIAGRAMA DEL ASA

#	DESCRIPCIÓN	CANT.	NO. DE PARTE DE ULINE	NO. DE PARTE DEL FABRICANTE
A	Ensamble del Asa	1	H-2722-HANDL	ALL-T-2-14-HCA
1	Asa	1	-----	PM-ALT-1
2	Resorte	1	-----	PM-ALT-2
3	Pasador del Rodillo	1	-----	PM-ALT-3
4	Buje 1615	4	-----	PM-ALT-4
5	Rodillo	1	-----	PM-ALT-5
6	Pasador con Resorte de 3x28	1	H-2722-40535	40535
7	Palanca	1	-----	PM-ALT-30
8	Varilla de Liberación	1	-----	PM-ALT-31
9	Unión de la Cadena	1	H-2722-ALT32	PM-ALT-32
10	Cadena	1	H-2722-ALT33	PM-ALT-33
11	Perno de Anclaje	1	-----	PM-ALT-34
12	Tuerca en V M6	1	H-2722-VNUT	PM-ALT-35

# ULINE H-2722

## PATÍN HIDRÁULICO

### TODOTERRENO

800-295-5510  
uline.mx

#### DIAGRAMA DE LA BOMBA

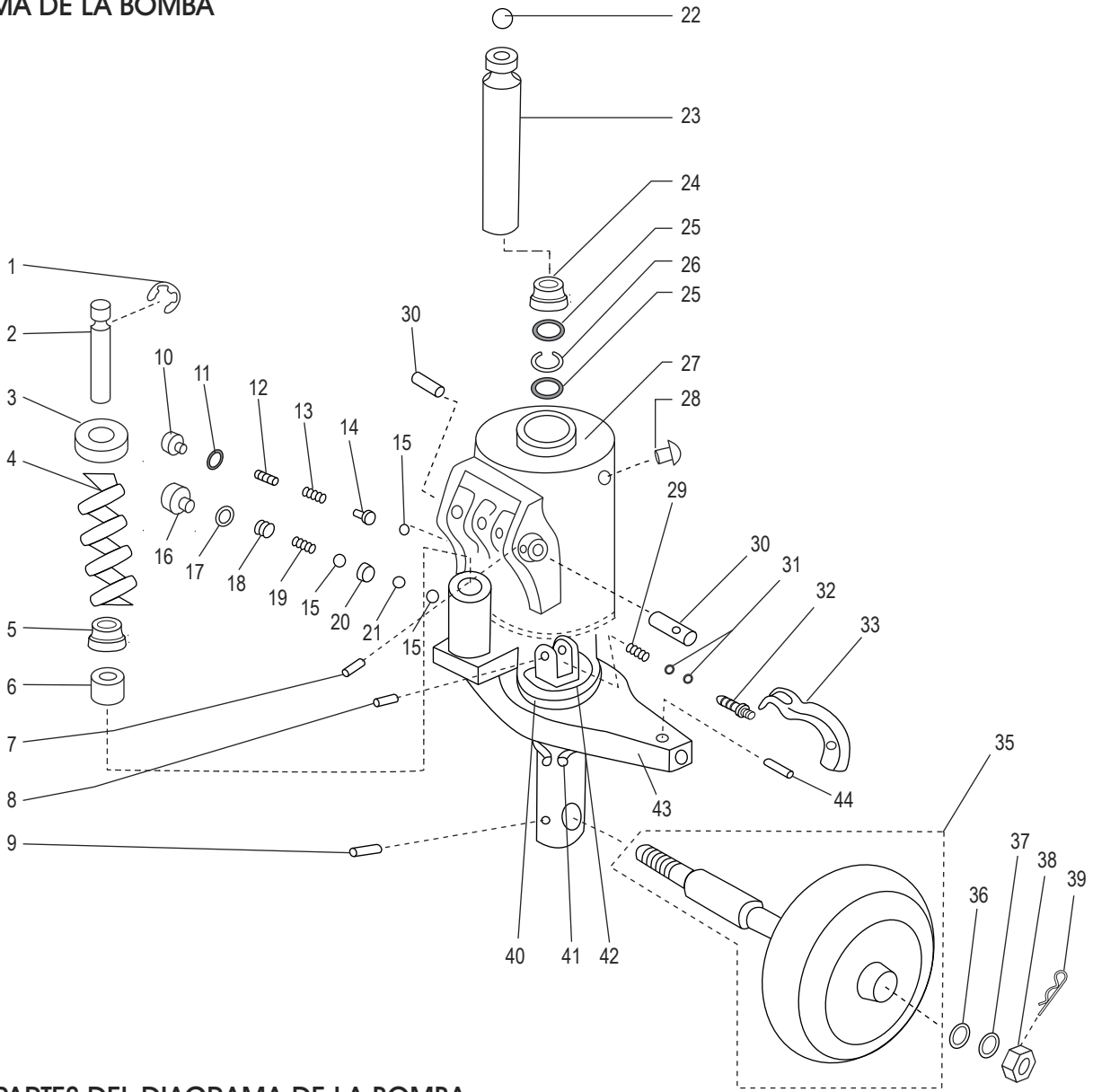

#### LISTA DE PARTES DEL DIAGRAMA DE LA BOMBA

#	DESCRIPCIÓN	CANT.	NO. DE PARTE DE ULINE	NO. DE PARTE DEL FABRICANTE
1	Anillo en E 15	1	H-2722-ERING	PM-ALT-9
2	Pistón del Émbolo	1	-----	PM-ALT-10
3	Tapa del Resorte	1	H-2722-CAP	PM-ALT-11
4	Resorte	1	-----	PM-ALT-12
5	Sello Antipolvo*	1	-----	PM-ALT-13
6	Anillo en U de 18x24x8	1	-----	PM-ALT-14
7	Pasador con Resorte de 3x28	1	H-2722-40535	40535
8	Pasador con Resorte de 8x25	1	-----	PM-ALT-16
9	Pasador con Resorte de 8x45	1	-----	PM-ALT-17

CONTINUACIÓN DE LA LISTA DE PARTES DEL DIAGRAMA DE LA BOMBA

#	DESCRIPCIÓN	CANT.	NO. DE PARTE DE ULINE	NO. DE PARTE DEL FABRICANTE
10	Conector de Alivio	1	-----	PM-ALT-18
11	Anillo Tórico de 11.2x2.4	1	-----	PM-ALT-19
12	Tornillo de Ajuste de Presión	1	-----	PM-ALT-20
13	Resorte	1	-----	PM-ALT-21
14	Base del Resorte	1	-----	PM-ALT-22
15	Bola de Acero 6	3	-----	PM-ALT-23
16	Conector de Liberación	1	-----	PM-ALT-24
17	Rondana	1	-----	PM-ALT-25
18	Resorte	1	-----	PM-ALT-26
19	Resorte	1	-----	PM-ALT-27
20	Válvula	1	-----	PM-ALT-28
21	Bola de Acero 9	1	-----	PM-ALT-29
22	Bola de Acero 14	1	H-2722-SB14	PM-ALT-36
23	Pistón	1	-----	PM-ALT-37
24	Sello Antipolvo*	1	-----	PM-ALT-38
25	Anillo Tórico de 29.85x3.5*	2	-----	PM-ALT-39
26	Anillo de Refuerzo*	1	-----	PM-ALT-40
27	Ensamble de la Cubierta de la Bomba	1	-----	PM-ALT-41
28	Tapón de Aceite	1	H-2722-P28Q	PM-ALT-42
29	Resorte	1	-----	PM-ALT-43
30	Pasador del Asa	2	H-2722-HNDLE	PM-ALT-8
31	Anillo Tórico de 4.8x1.9	2	H-2722-31	PM-ALT-46
32	Boquilla de Liberación	1	-----	PM-ALT-47
33	Leva	1	-----	PM-ALT-48
35	<b>Kit de Llantá Trasera</b> Incluye: • (2) Llantás • (1) Eje	1	H-2722-BWK	74-007-962
36	Sello del Cojinete	2	-----	PM-ALT-72
37	Rondana 16	2	-----	PM-ALT-51
38	Tuerca M16	2	H-2722-NUT	PM-ALT-52
39	Pasador Partido de 4x30	2	-----	PM-ALT-53
40	Cojinete 51109-Z	1	H-2722-ALT70	PM-ALT-70
41	Anillo de Presión 44	1	H-2722-SRING	PM-ALT-66
42	Base del Cojinete	1	-----	PM-ALT-69
43	Mesa	1	-----	PM-ALT-71
44	Pasador con Resorte	2	-----	-----

**ULINE H-2722**  
**PATÍN HIDRÁULICO**  
**TODOTERRENO**

800-295-5510  
 uline.mx

CONTINUACIÓN DE LA LISTA DE PARTES DEL DIAGRAMA DE LA BOMBA

#	DESCRIPCIÓN	CANT.	NO. DE PARTE DE ULINE	NO. DE PARTE DEL FABRICANTE
	*Kit de Sellos (No se Muestra) Incluye: • (1) Sello Limpiador Grande • (1) Sello para Recipiente en U Grande • (1) Sello Limpiador Chico • (1) Sello para Recipiente en U Chico • (1) Anillo Tórico de 35.5 x 3 • (1) Anillo Tórico de 17 x 2.6 • (1) Sello para Aceite de 10.5 x 2.6 • (2) Anillos Tóricos de 8.44 x 1.8	1	H-2722-KIT	-----
	Ensamble de la Bomba (No se muestra)	1	H-2722-PUMP	PM-ALT-PCA

**ULINE H-2722**  
**TRANSPALETTE**  
**TOUT-TERRAIN**

1 800 295-5510  
uline.ca



SCHÉMA DE LA STRUCTURE



## LISTE DES PIÈCES DU SCHÉMA DE LA STRUCTURE

#	DESCRIPTION	QTÉ	RÉF. ULINE	RÉF. DU FABRICANT
1	Arbre	1	-----	PM-ALT-54
2	Plaque d'installation	1	H-2722-PLATE	PM-ALT-55
3	Arbre	2	H-2722-SHAFT	PM-ALT-56
4	Goupille	2	-----	PM-ALT-44
5	Bague, 1620	2	-----	PM-ALT-45
6	Fourche	2	-----	PM-ALT-57
7	Vis, M6 x35	1	-----	PM-ALT-58
8	Rouleau-guide	4	-----	PM-ALT-59
9	Bague, 0808	4	-----	PM-ALT-60
10	Axe de rouleau-guide	4	-----	PM-ALT-61
11	Roulement, 6206-Z	4	-----	PM-ALT-62
12	Capuchon d'essieu de roulement	4	-----	PM-ALT-63
13	Rondelle	4	H-2722-WASH	PM-ALT-64
14	Roue avant	2	H-2722-WHEEL	PM-ALT-65
15	Rondelle 16	2	H-2722-W16	40361
16	Goupille fendue, 4 x 30	2	H-2722-SPIN	0162010
17	Écrou M16	2	H-2722-NUT	PM-ALT-52
18	Cadre principal	1	-----	PM-ALT-67
19	Couvercle antipoussière	2	-----	PM-ALT-68
20	Ensemble de la poignée	1	H-2722-HANDL	ALL-T-2-14-HCA

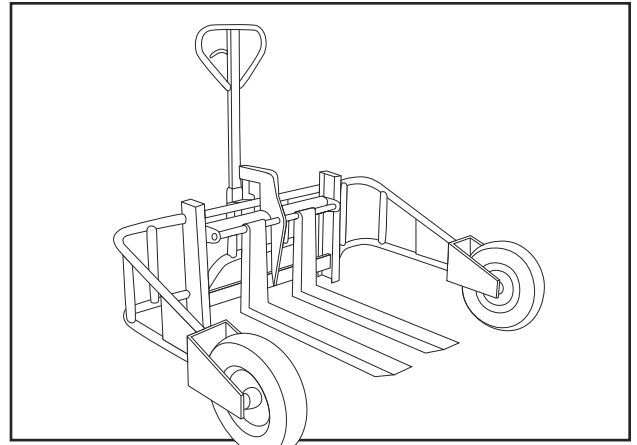
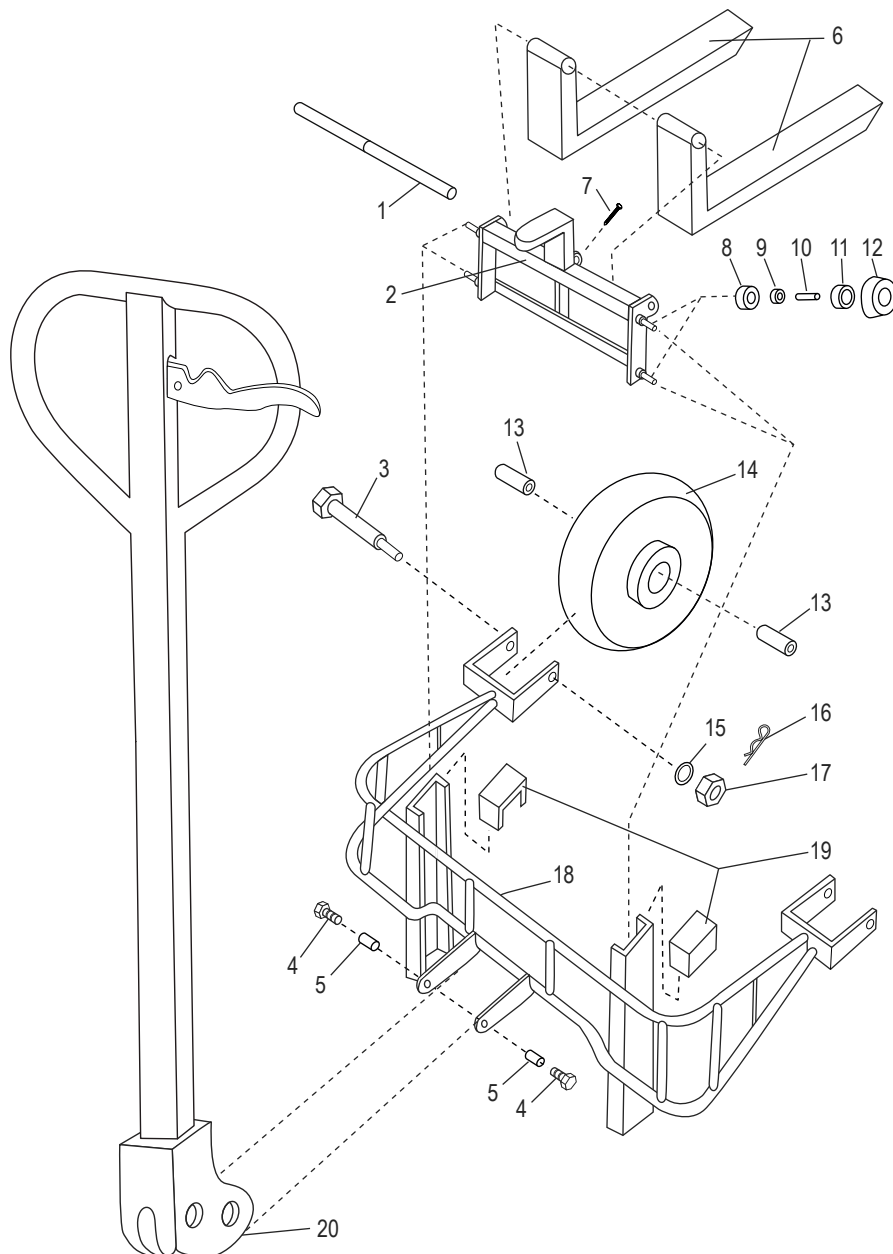
**TRANSPALETTE  
TOUT-TERRAIN**

## SCHÉMA DE LA POIGNÉE

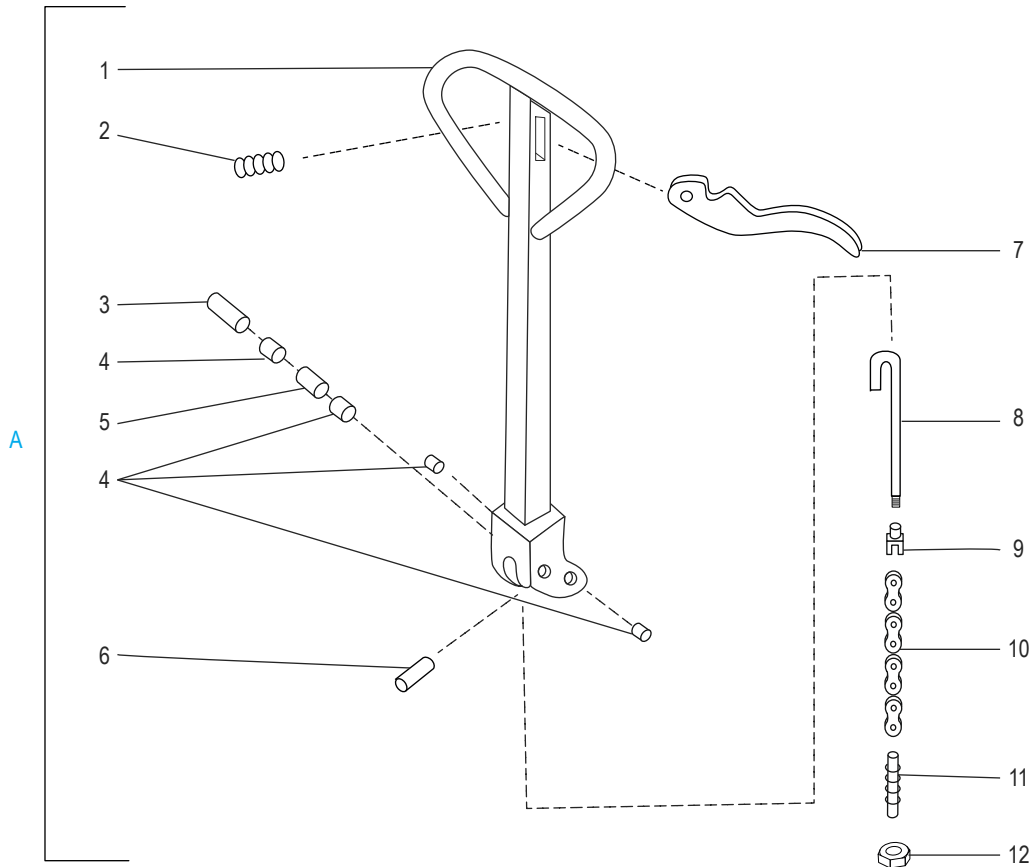

## LISTE DES PIÈCES DU SCHÉMA DE LA POIGNÉE

#	DESCRIPTION	QTÉ	RÉF. ULINE	RÉF. DU FABRICANT
A	Ensemble de la poignée	1	H-2722-HANDL	ALL-T-2-14-HCA
1	Poignée	1	-----	PM-ALT-1
2	Ressort	1	-----	PM-ALT-2
3	Goupille de rouleau	1	-----	PM-ALT-3
4	Bague, 1615	4	-----	PM-ALT-4
5	Rouleau	1	-----	PM-ALT-5
6	Cheville ressort, 3 x 28	1	H-2722-40535	40535
7	Levier	1	-----	PM-ALT-30
8	Tringle de déclenchement	1	-----	PM-ALT-31
9	Joint de chaîne	1	H-2722-ALT32	PM-ALT-32
10	Chaîne	1	H-2722-ALT33	PM-ALT-33
11	Boulon d'ancrage	1	-----	PM-ALT-34
12	Écrou en V M6	1	H-2722-VNUT	PM-ALT-35

# ULINE H-2722

## TRANSPALETTE TOUT-TERRAIN

1 800 295-5510  
uline.ca

### SCHÉMA DE LA POMPE

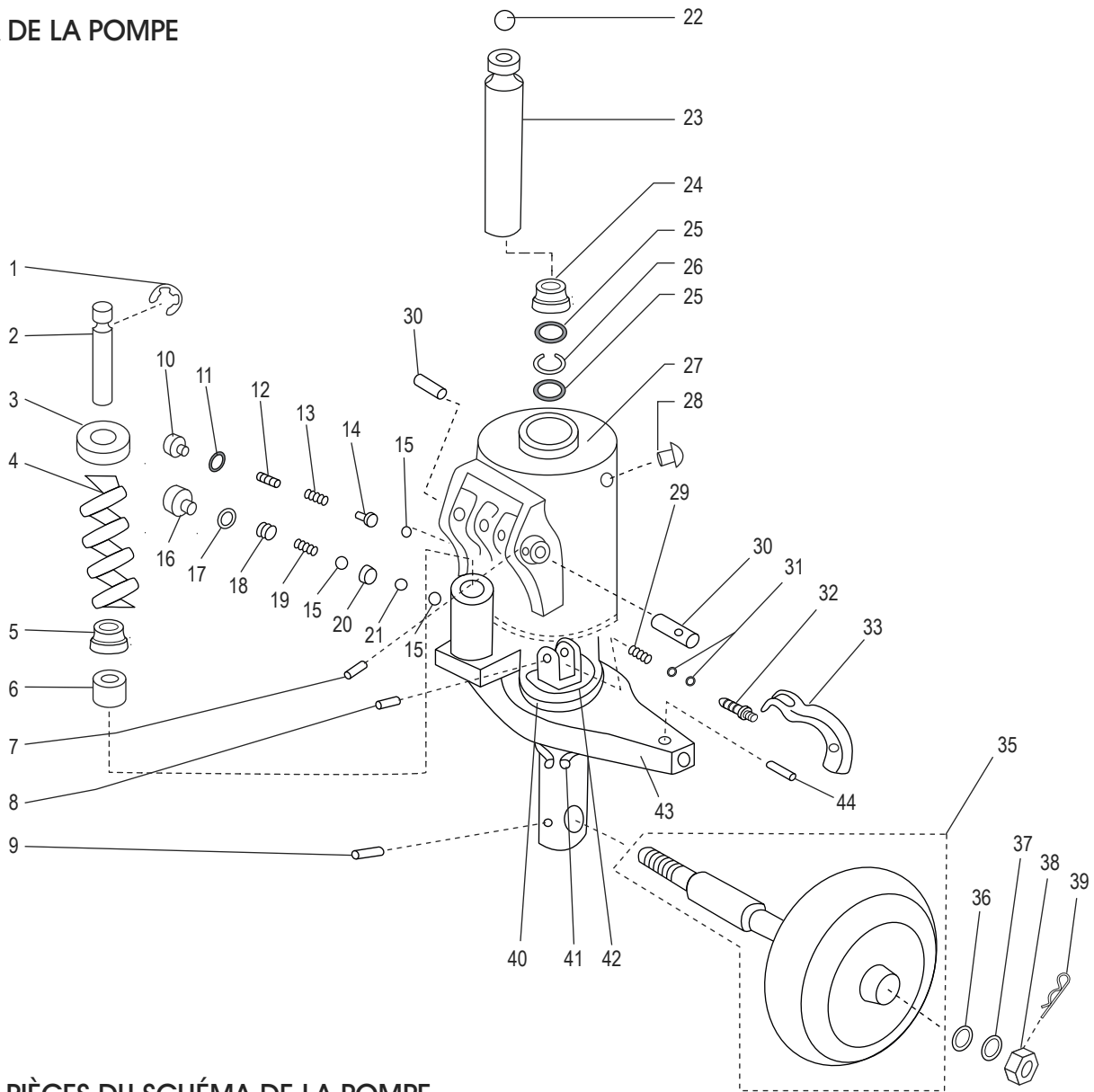

### Liste des pièces du schéma de la pompe

#	DESCRIPTION	QTÉ	RÉF. ULINE	RÉF. DU FABRICANT
1	Anneau en E 15	1	H-2722-ERING	PM-ALT-7
2	Piston plongeur	1	-----	PM-ALT-10
3	Coiffe de ressort	1	H-2722-CAP	PM-ALT-11
4	Ressort	1	-----	PM-ALT-12
5	Joint antipoussière*	1	-----	PM-ALT-13
6	Anneau en U, 18 x 24 x 8	1	-----	PM-ALT-14
7	Cheville ressort, 3 x 28	1	H-2722-40535	40535
8	Cheville ressort, 8 x 25	1	-----	PM-ALT-16
9	Cheville ressort, 8 x 45	1	-----	PM-ALT-17



## LISTE DES PIÈCES DU SCHÉMA DE LA POMPE SUITE

#	DESCRIPTION	QTÉ	RÉF. ULINE	RÉF. DU FABRICANT
10	Bouchon de surpression	1	-----	PM-ALT-18
11	Joint torique, 11,2 x 2,4	1	-----	PM-ALT-19
12	Vis de réglage de la pression	1	-----	PM-ALT-20
13	Ressort	1	-----	PM-ALT-21
14	Base de ressort	1	-----	PM-ALT-22
15	Bille d'acier 6	3	-----	PM-ALT-23
16	Bouchon de déclenchement	1	-----	PM-ALT-24
17	Rondelle	1	-----	PM-ALT-25
18	Ressort	1	-----	PM-ALT-26
19	Ressort	1	-----	PM-ALT-27
20	Soupape	1	-----	PM-ALT-28
21	Bille d'acier 9	1	-----	PM-ALT-29
22	Bille d'acier 14	1	H-2722-SB14	PM-ALT-36
23	Piston de course	1	-----	PM-ALT-37
24	Joint antipoussière*	1	-----	PM-ALT-38
25	Joint torique, 29,85 x 3,5*	2	-----	PM-ALT-39
26	Bague d'appui*	1	-----	PM-ALT-40
27	Boîtier de pompe	1	-----	PM-ALT-41
28	Bouchon d'huile	1	H-2722-P28Q	PM-ALT-42
29	Ressort	1	-----	PM-ALT-43
30	Cheville de poignée	2	H-2722-HNDLE	PM-ALT-8
31	Joint torique, 4,8 x 1,9	2	H-2722-31	PM-ALT-46
32	Buse de dégagement	1	-----	PM-ALT-47
33	Came	1	-----	PM-ALT-48
35	<b>Ensemble de la roue arrière</b> Comprend : • Roue (2) • Arbre (1)	1	H-2722-BWK	74-007-962
36	Bague d'étanchéité de roulement	2	-----	PM-ALT-72
37	Rondelle 16	2	-----	PM-ALT-51
38	Écrou M16	2	H-2722-NUT	PM-ALT-52
39	Goupille fendue, 4 x 30	2	-----	PM-ALT-53
40	Roulement, 51109-Z	1	H-2722-ALT70	PM-ALT-70
41	Anneau de retenue 44	1	H-2722-SRING	PM-ALT-66
42	Base de roulement	1	-----	PM-ALT-69
43	Table	1	-----	PM-ALT-71
44	Cheville ressort	2	-----	-----

LISTE DES PIÈCES DU SCHÉMA DE LA POMPE SUITE

#	DESCRIPTION	QTÉ	RÉF. ULINE	RÉF. DU FABRICANT
	*Ensemble de joint (non illustré) Comprend : <ul style="list-style-type: none"> <li>• Grand joint racleur (1)</li> <li>• Grand joint en coupelle (1)</li> <li>• Petit joint racleur (1)</li> <li>• Petit joint en coupelle (1)</li> <li>• Joint torique 35,5 x 3 (1)</li> <li>• Joint torique 17 x 2,6 (1)</li> <li>• Joint étanche à l'huile 10,5 x 2,6 (1)</li> <li>• Joint torique 8,44 x 1,8 (2)</li> </ul>	1	H-2722-KIT	-----
	Ensemble de la pompe (non illustré)	1	H-2722-PUMP	PM-ALT-PCA