

ULINE H-3762, H-3763

QUICK-LIFT PALLET TRUCK

1-800-295-5510
uline.com

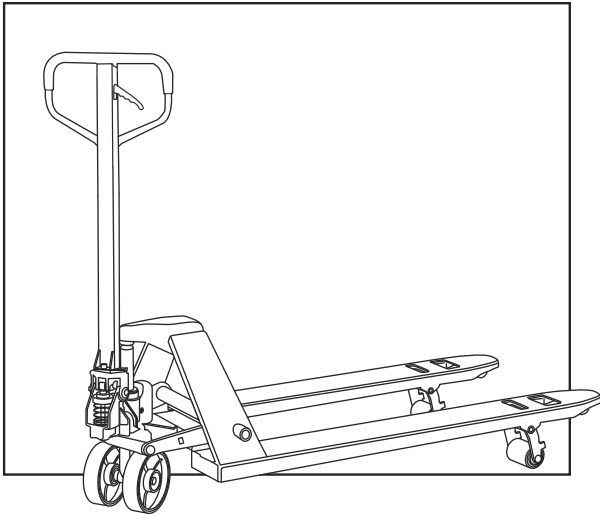

FRAME DIAGRAM

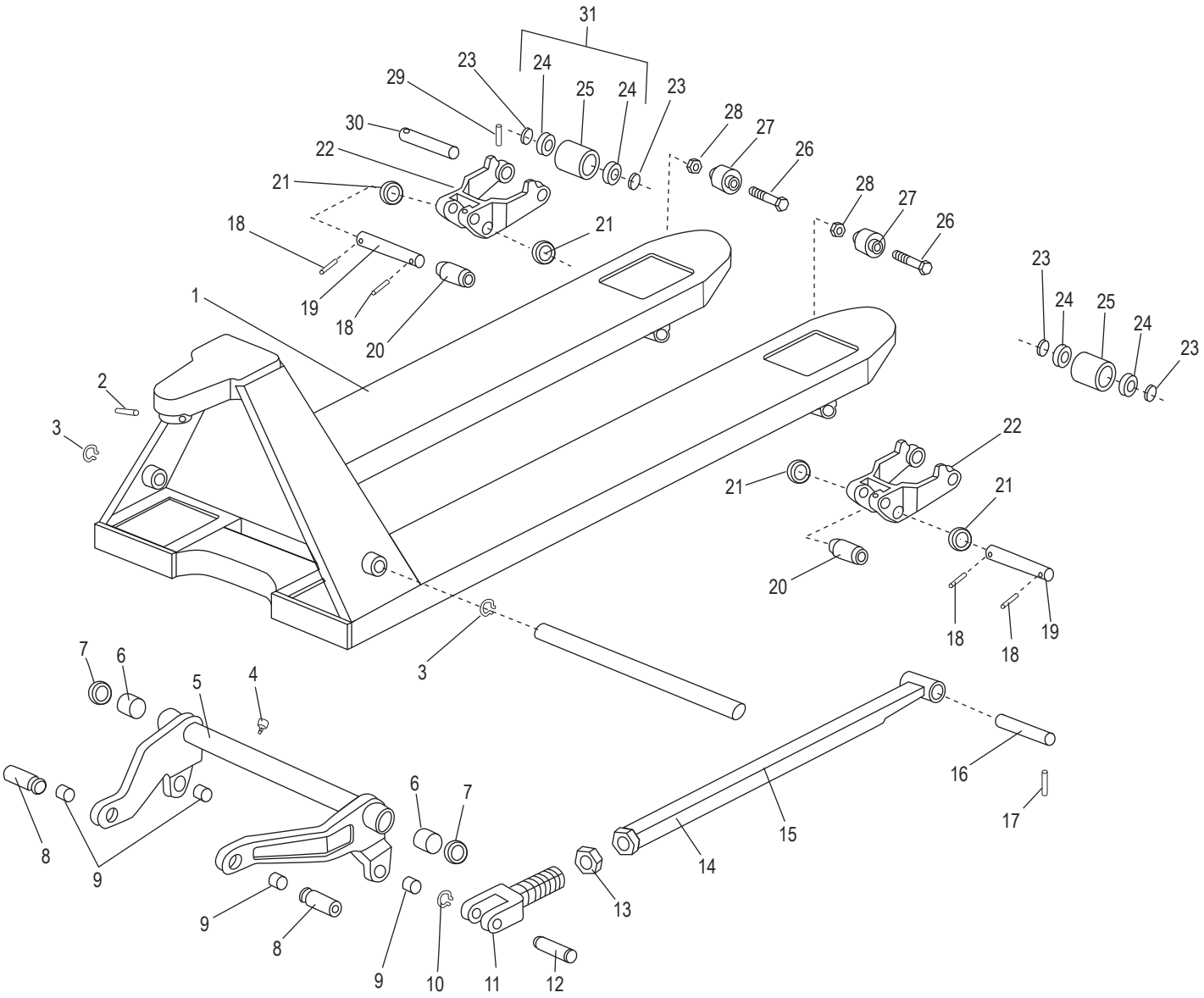

**QUICK-LIFT
PALLET TRUCK**

FRAME DIAGRAM PARTS LIST CONTINUED

#	DESCRIPTION	QTY.	ULINE PART NO.	MFG. PART NO.
1	Fork Frame	1	-----	201-RAL5015
2	Bolt	1	H-3045-202G	202G
3	Retaining Ring	2	H-2900-213	213
4	Grease Cup	1	H-2186-237	237
5	Rock - Arm	1	H-4121-RKARM	203
6	Bushing	2	H-2185-206S	204
7	Washer	2	H-2185-236S	236S
8	Shaft	2	H-2708-205	205
9	Bushing	4	H-2708-AC206	206
10	Retaining Ring	2	H-2708-AC208	208
11	Joint	2	H-2708-AC209	AC-209
12	Pin	2	H-2708-PIN	210
13	Nut	2	H-2708-AC211	AC-211
14	Pushing Rod	2	H-2708-21248	AC-212-48"FORK
15	Shaft	1	H-2708-214	214
16	Shaft	2	H-2900-216	216
17	Elastic Pin	2	H-2900-219	219
18	Elastic Pin	4	H-2186-220ZS	220ZS
19	Shaft	2	H-2900-19	221
20	Extending Roller	2	H-2186-218	218
21	Intermediate Roller	4	H-2186-217ZS	217ZS
22	Frame of Fork (Load) Wheel	2	H-2900-222	222
23	Washer	4	H-2708-AC225	AC-225
24	Bearing	4	H-2708-AC226	AC-226
25	Fork (Load) Wheel	2	H-2708-AC234	AC-234#POLY
26	Bolt	2	H-2708-AC231	AC-231
27	Entry (Roller) Wheel	2	H-2708-AC232	AC-232
28	Locking Nut	2	H-2708-AC233	AC-233
29	Spring Pin	2	H-2708-AC230	AC-230
30	Shaft for Fork (Load) Wheel	2	H-2708-AC235	AC-235#
31	Fork (Load) Wheel Kit Includes: • Fork (Load) Wheel (1) • Bearing (2)	2	H-5599	226 234#POLY

**QUICK-LIFT
PALLET TRUCK**

HANDLE DIAGRAM

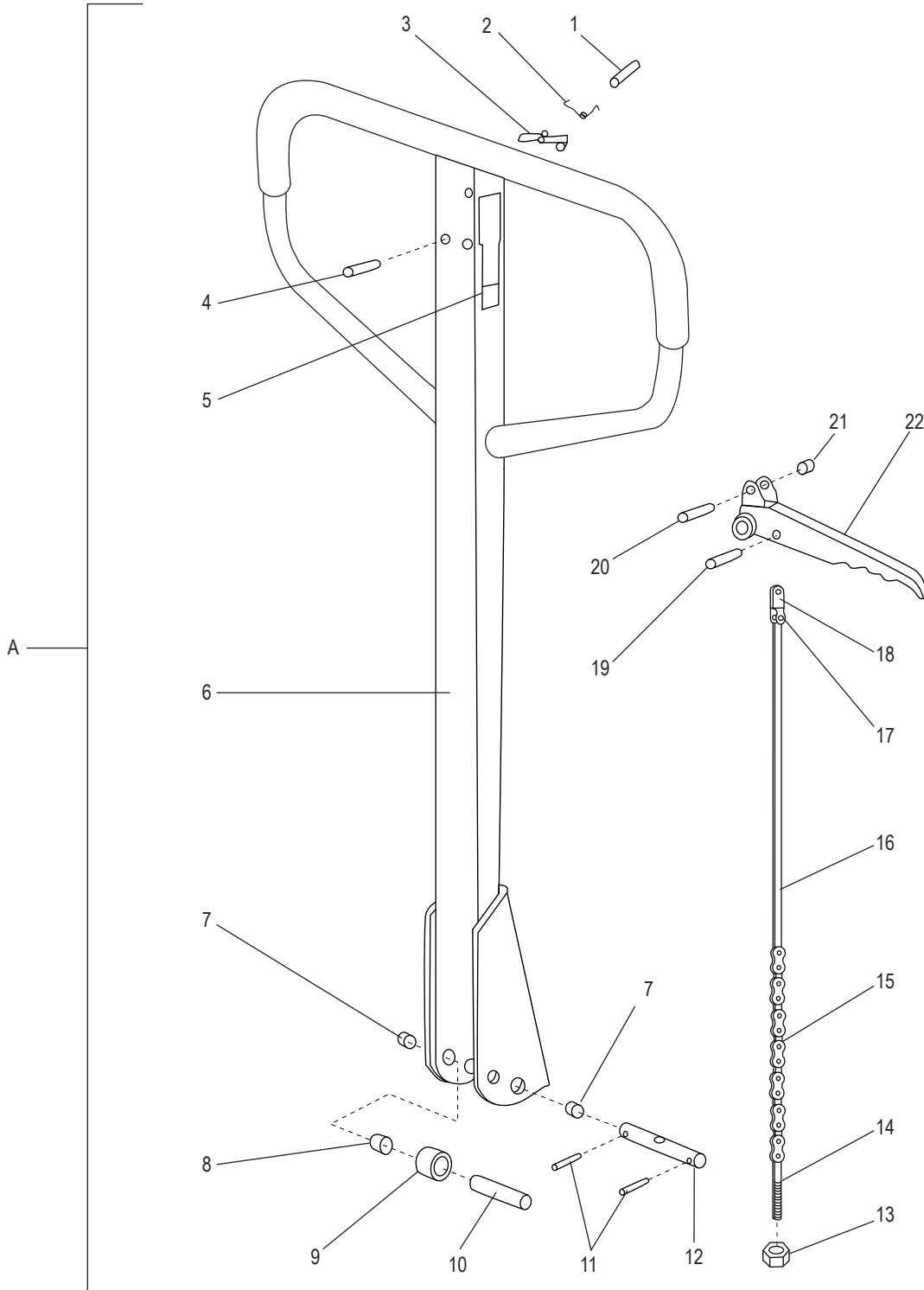

**QUICK-LIFT
PALLET TRUCK**

HANDLE DIAGRAM PARTS LIST

#	DESCRIPTION	QTY.	ULINE PART NO.	MFG. PART NO.
A	Handle Assembly	1	H-3811	ACQL330HANDLEA
1	Elastic Pin	1	H-2900-115	115
2	Spring	1	H-3763-114	114
3	Blade Spring	1	H-2900-113	113
4	Elastic Pin	1	H-2708-112	112
5	Stop Rubber	1	H-2186-111	111
6	Draw Bar	1	H-2708-110	110
7	Bushing	2	H-2708-AC107	AC-107
8	Bushing	1	H-2708-109A	AC-109A
9	Pressure Roller	1	H-2708-AC109	AC-109
10	Roller Pin	1	H-2708-AC108	AC-108
11	Elastic Pin	2	H-2708-AC106	AC-106
12	Axle with Hole	1	H-2708-AC105	AC-105
13	Adjusting Nut	1	H-2708-104	104
14	Adjusting Bolt	1	H-2186-103	103
15	Chain	1	H-2708-102	102
16	Release Rod	1	H-2708-AC101	101
17	Pin	1	H-2708-AC122	122
18	Pull Board	1	H-2708-AC121	121
19	Elastic Pin	1	H-2708-AC116	116
20	Elastic Pin	1	H-2708-AC119	119
21	Roller	1	H-2708-AC118	118
22	Control Handle	1	H-2708-AC117	117

**QUICK-LIFT
PALLET TRUCK**

PUMP DIAGRAM

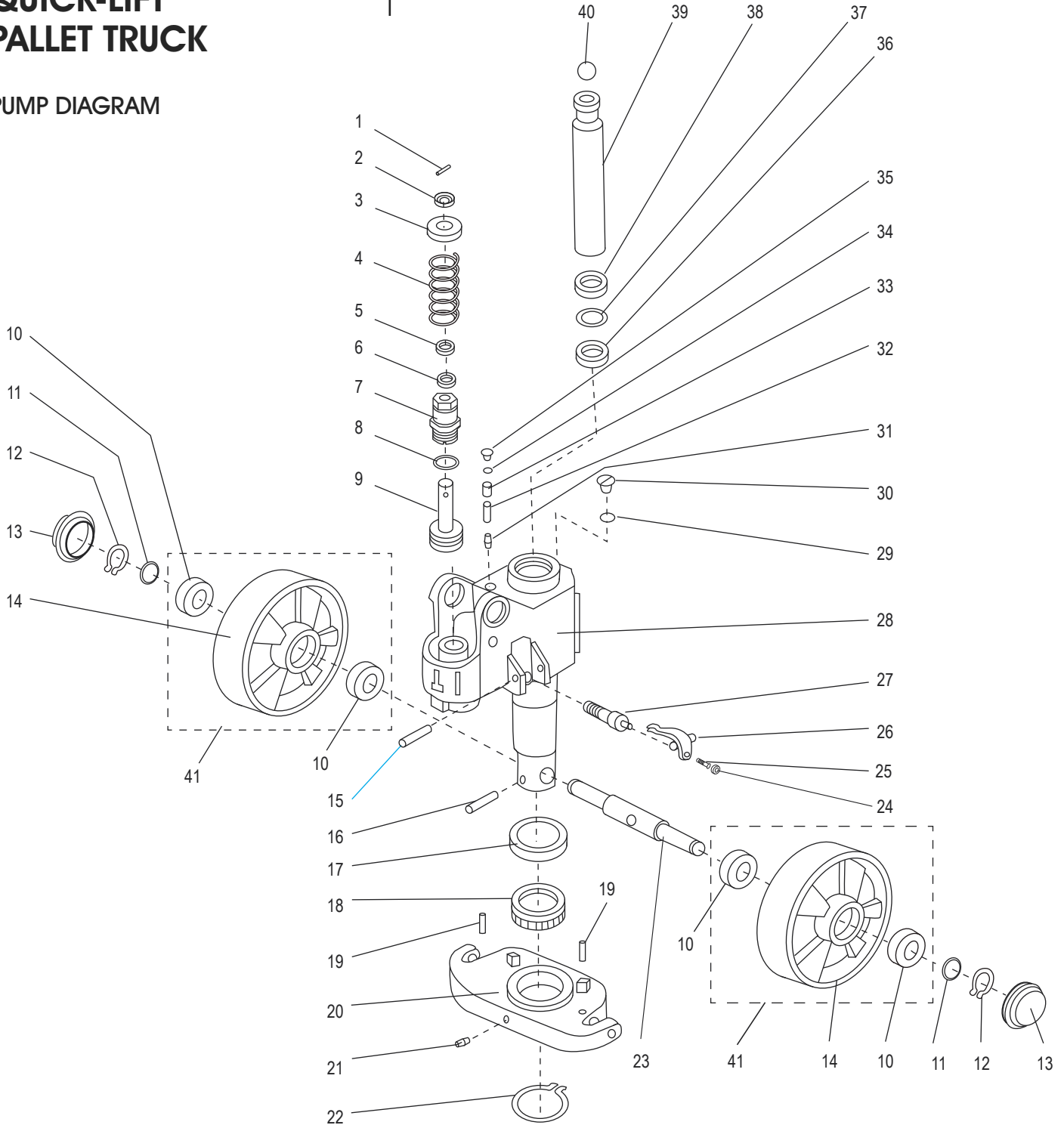

PUMP DIAGRAM PARTS LIST

#	DESCRIPTION	QTY.	ULINE PART NO.	MFG. PART NO.
B	Pump Assembly (Not Shown)	1	H-3812	ACQL330PUMPASB
1	Pin	1	H-5237	335F
2	Cap of Pin	1	H-6083	336F
3	Spring Cap	1	H-3763-301F	301F

**QUICK-LIFT
PALLET TRUCK****PUMP DIAGRAM PARTS LIST CONTINUED**

#	DESCRIPTION	QTY.	ULINE PART NO.	MFG. PART NO.
4	Spring	1	H-3763-302F	302F
5	Dust Ring	1	H-2185-DR	304
6	Seal	1	H-3763-305	305
7	Pump Cylinder	1	H-3763-338F	338F
8	O-Ring	1	H-3762-337F	337F
9	Pump Piston for Quick Lifting	1	H-3763-303F	303F
10	Bearing	4	H-2708-AC309	AC-309
11	Washer	2	H-2708-AC308	AC-308
12	Spring Washer	2	H-2708-AC307	AC-307
13	Dust Cover	2	H-2708-AC306	AC-306
14	Big (Steering) Wheel	2	H-2708-AC310	AC-310POLY
15	Elastic Pin	1	H-2900-320	320
16	Elastic Pin	1	H-2900-311	311
17	Cover of Bearing	1	H-2186-337	337
18	Bearing	1	H-2186-315	315
19	Elastic Pin	2	H-2900-312	312
20	Thrust Plate	1	H-2186-313	313
21	Grease Cup	1	H-2900-335	335
22	Retaining Ring	1	H-2186-314	314
23	Shaft of Big (Steering) Wheel	1	H-2708-AC316	316
24	Nut	1	H-2708-317	317
25	Screw	1	H-2708-318	318
26	Lever Plate	1	H-2900-LEVER	319
27	Valve Cartridge	1	H-2708-AC321	321
28	Pump for Quick Lifting	1	H-3763-322F	322F
29	Seal Washer	1	H-2900-323	323
30	Screw Plug	1	H-2900-324	324
31	Spindle of Safety Valve	1	H-2900-334	334
32	Spring	1	H-2900-333	333
33	Bolt	1	H-2900-332	332
34	O-Ring	1	H-2900-331	331
35	Screw Plug	1	H-2900-330	330
36	Seal	1	H-3762-36	325
37	O-Ring	1	H-3762-37	326
38	Dust Ring	1	H-3762-38	327
39	Piston Rod	1	H-2900-328	328
40	Steel Ball	1	H-2900-329	329
41	Pallet Truck Steering Wheel Kit Includes: • Bearing (2) • Big (Steering) Wheel (1)	2	H-5384	-----

ULINE H-3762, H-3763

PATÍN HIDRÁULICO DE LEVANTAMIENTO RÁPIDO

800-295-5510
uline.mx



DIAGRAMA DEL ARMAZÓN



ULINE H-3762, H-3763
**PATÍN HIDRÁULICO DE
 LEVANTAMIENTO RÁPIDO**

800-295-5510
 uline.mx

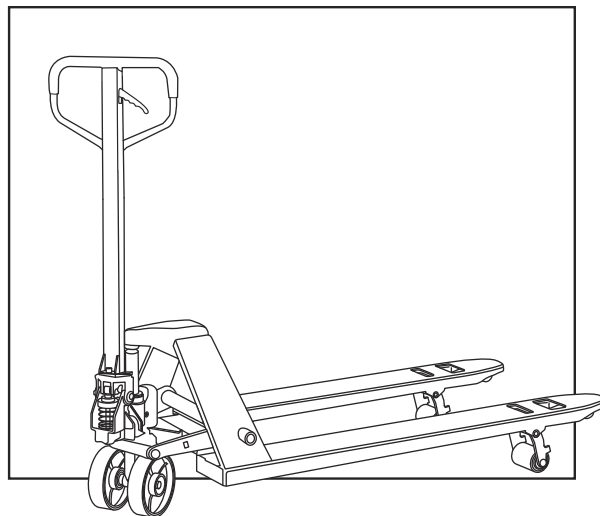
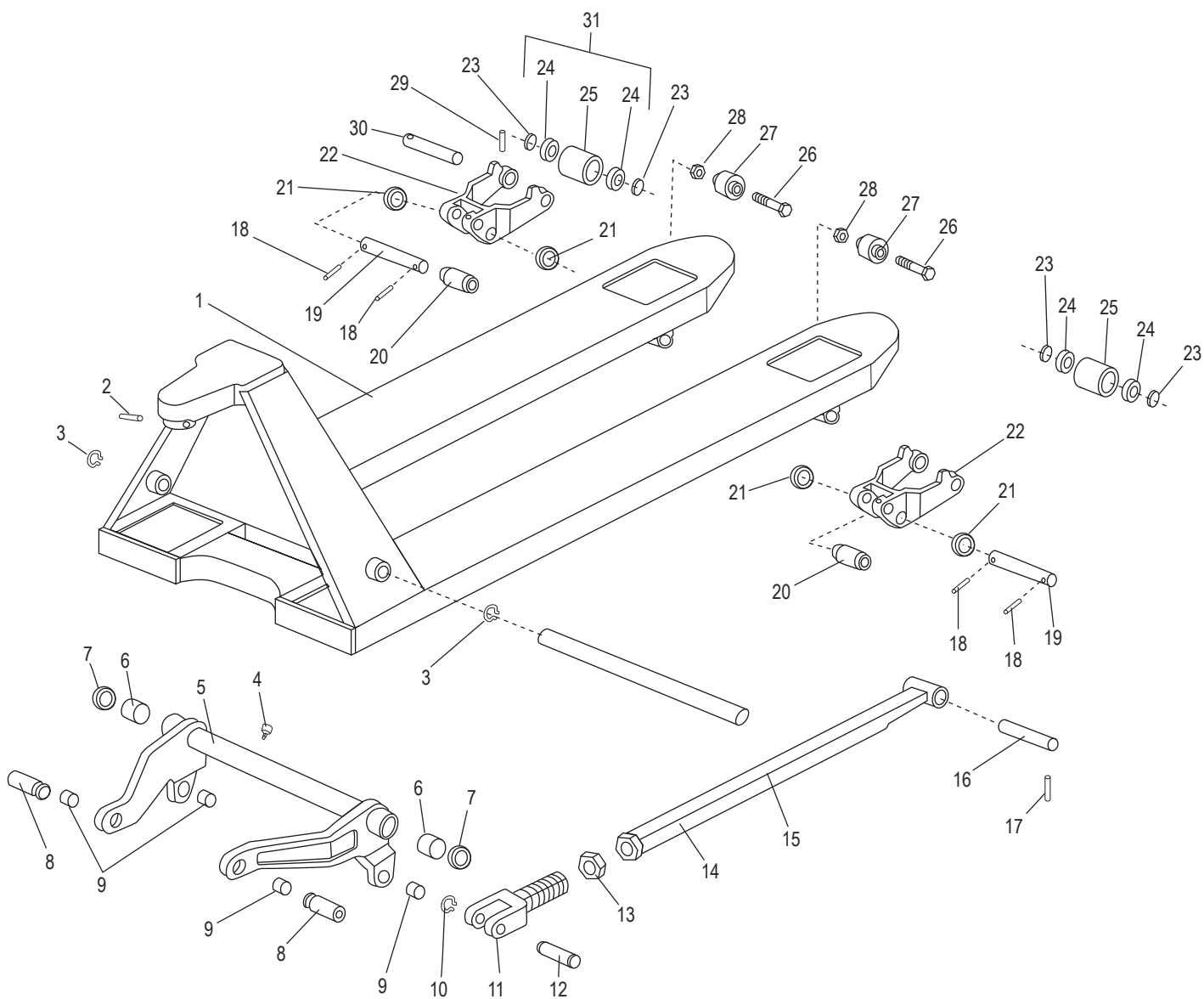
CONTINUACIÓN DE LISTA DE PARTES DEL DIAGRAMA DEL ARMAZÓN

#	DESCRIPCIÓN	CANT.	NO. DE PARTE DE ULINE	NO. DE PARTE DEL FABRICANTE
1	Armazón de la Horquilla	1	-----	201-RAL5015
2	Perno	1	H-3045-202G	202G
3	Aro de Retención	2	H-2900-213	213
4	Recipiente para Grasa	1	H-2186-237	237
5	Brazo del Balancín	1	H-4121-RKARM	203
6	Buje	2	H-2185-206S	204
7	Rondana	2	H-2185-236S	236
8	Eje	2	H-2708-205	205
9	Buje	4	H-2708-AC206	206
10	Aro de Retención	2	H-2708-AC208	208
11	Unión	2	H-2708-AC209	AC-209
12	Pasador	2	H-2708-PIN	210
13	Tuerca	2	H-2708-AC211	AC-211
14	Varilla de Empuje	2	H-2708-21248	AC-212-48"FORK
15	Eje	1	H-2708-214	214
16	Eje	2	H-2900-216	216
17	Pasador Elástico	2	H-2900-219	219
18	Pasador Elástico	4	H-2186-220ZS	220ZS
19	Eje	2	H-2900-19	221
20	Rodillo Extensor	2	H-2186-218	218
21	Rodillo Intermedio	4	H-2186-217ZS	217ZS
22	Armazón de la Lanta de Horquilla (Carga)	2	H-2900-222	222
23	Rondana	4	H-2708-AC225	AC-225
24	Cojinete	4	H-2708-AC226	AC-226
25	Lanta de Horquilla (Carga)	2	H-2708-AC234	AC-234#POLY
26	Perno	2	H-2708-AC231	AC-231
27	Lanta de Acceso (Rodillo)	2	H-2708-AC232	AC-232
28	Contratuerca	2	H-2708-AC233	AC-233
29	Pasador con Resorte	2	H-2708-AC230	AC-230
30	Eje de la Lanta de Horquilla (Carga)	2	H-2708-AC235	AC-235#
31	Kit de Repuesto de la Lanta de Horquilla Incluye: • Lanta de Carga • Cojinete de la Lanta de Carga	2	H-5599	226 234#POLY

ULINE H-3762, H-3763
**PATÍN HIDRÁULICO DE
LEVANTAMIENTO RÁPIDO**

800-295-5510
uline.mx

DIAGRAMA DEL ASA

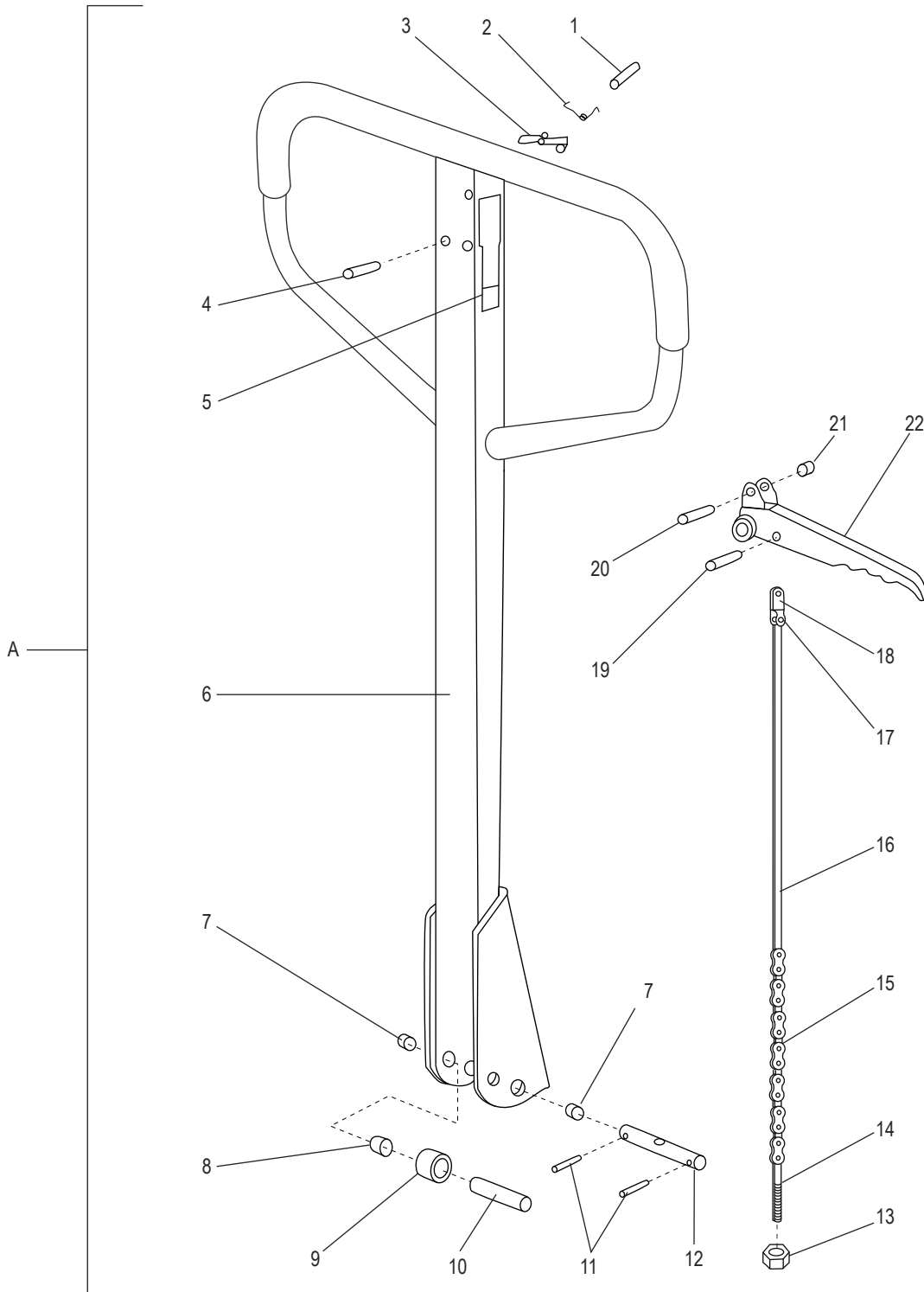

ULINE H-3762, H-3763
**PATÍN HIDRÁULICO DE
 LEVANTAMIENTO RÁPIDO**

800-295-5510
 uline.mx

LISTA DE PARTES DEL DIAGRAMA DEL ASA

#	DESCRIPCIÓN	CANT.	NO. DE PARTE DE ULINE	NO. DE PARTE DEL FABRICANTE
A	Ensamble del Asa	1	H-3811	ACQL330HANDLEA
1	Pasador Elástico	1	H-2900-115	115
2	Resorte	1	H-3763-114	114
3	Resorte con Hoja	1	H-2900-113	113
4	Pasador Elástico	1	H-2708-112	112
5	Tope de Goma	1	H-2186-111	111
6	Barra de Empuje	1	H-2708-110	110
7	Buje	2	H-2708-AC107	AC-107
8	Buje	1	H-2708-109A	AC-109A
9	Rodillo de Presión	1	H-2708-AC109	AC-109
10	Pasador del Rodillo	1	H-2708-AC108	AC-108
11	Pasador Elástico	2	H-2708-AC106	AC-106
12	Eje con Orificio	1	H-2708-AC105	AC-105
13	Tuerca de Ajuste	1	H-2708-104	104
14	Perno de Ajuste	1	H-2186-103	103
15	Cadena	1	H-2708-102	102
16	Varilla de Liberación	1	H-2708-AC101	101
17	Pasador	1	H-2708-AC122	122
18	Tablero de Empuje	1	H-2708-AC121	121
19	Pasador Elástico	1	H-2708-AC116	116
20	Pasador Elástico	1	H-2708-AC119	119
21	Rodillo	1	H-2708-AC118	118
22	Asa de Control	1	H-2708-AC117	117

DIAGRAMA DE LA BOMBA

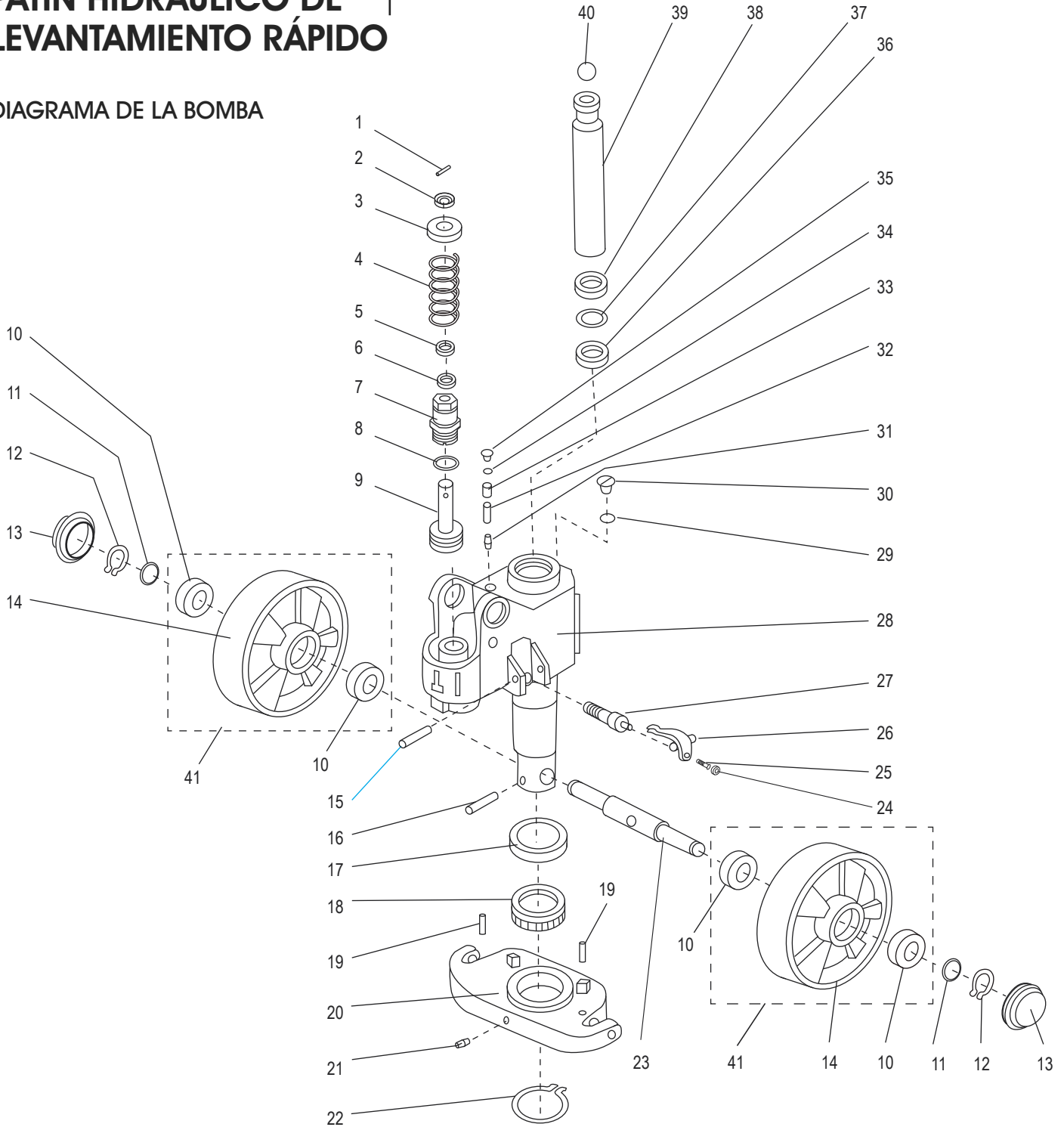

LISTA DE PARTES DEL DIAGRAMA DE LA BOMBA

#	DESCRIPCIÓN	CANT.	NO. DE PARTE DE ULINE	NO. DE PARTE DEL FABRICANTE
B	Ensamble de la Bomba (No se muestra)	1	H-3812	ACQL330PUMPASB
1	Pasador	1	H-5237	335F
2	Tapa del Pasador	1	H-6083	336F
3	Tapa del Resorte	1	H-3763-301F	301F

**PATÍN HIDRÁULICO DE
LEVANTAMIENTO RÁPIDO**

CONTINUACIÓN DE LISTA DE PARTES DEL DIAGRAMA DE LA BOMBA

#	DESCRIPCIÓN	CANT.	NO. DE PARTE DE ULINE	NO. DE PARTE DEL FABRICANTE
4	Resorte	1	H-3763-302F	302F
5	Anillo a Prueba de Polvo	1	H-2185-DR	304
6	Sello	1	H-3763-305	305
7	Cilindro de la Bomba	1	H-3763-338F	338F
8	Anillo-O	1	H-3762-337F	337F
9	Pistón de la Bomba para Elevación Rápida	1	H-3763-303F	303F
10	Cojinete	4	H-2708-AC309	AC-309
11	Rondana	2	H-2708-AC308	AC-308
12	Rondana con Resorte	2	H-2708-AC307	AC-307
13	Cubierta para Polvo	2	H-2708-AC306	AC-306
14	Llanta Grande (de Dirección)	2	H-2708-AC310	AC-310POLY
15	Pasador Elástico	1	H-2900-320	320
16	Pasador Elástico	1	H-2900-311	311
17	Cubierta del Cojinete	1	H-2186-337	337
18	Cojinete	1	H-2186-315	315
19	Pasador Elástico	2	H-2900-312	312
20	Placa de Empuje	1	H-2186-313	313
21	Recipiente para Grasa	1	H-2900-335	335
22	Aro de Retención	1	H-2186-314	314
23	Eje de la Llanta Grande (de Dirección)	1	H-2708-AC316	316
24	Tuerca	1	H-2708-317	317
25	Tornillo	1	H-2708-318	318
26	Placa de la Palanca	1	H-3763-319	319
27	Cartucho de la Válvula	1	H-2708-AC321	321
28	Bomba para Elevación Rápida	1	H-3763-322F	322F
29	Rondana de Sellado	1	H-2900-323	323
30	Conector del Tornillo	1	H-2900-324	324
31	Eje de la Válvula de Seguridad	1	H-2900-334	334
32	Resorte	1	H-2900-333	333
33	Perno	1	H-2900-332	332
34	Anillo-O	1	H-2900-331	331
35	Conector del Tornillo	1	H-2900-330	330
36	Sello	1	H-3762-36	325
37	Anillo-O	1	H-3762-37	326
38	Anillo a Prueba de Polvo	1	H-3762-38	327
39	Varilla de Pistón	1	H-2900-328	328
40	Bola de Acero	1	H-2900-329	329
41	Kit de la Llanta de Dirección del Patín Hidráulico Incluye: • 2 Cojinetes • 1 Llanta Grande (de Dirección)	2	H-5384	-----

ULINE H-3762, H-3763
**TRANSPALETTE
À LEVAGE RAPIDE**

1 800 295-5510
uline.ca



SCHÉMA DE LA STRUCTURE



**TRANSPALETTE
À LEVAGE RAPIDE**

LISTE DES PIÈCES DU SCHÉMA DE LA STRUCTURE

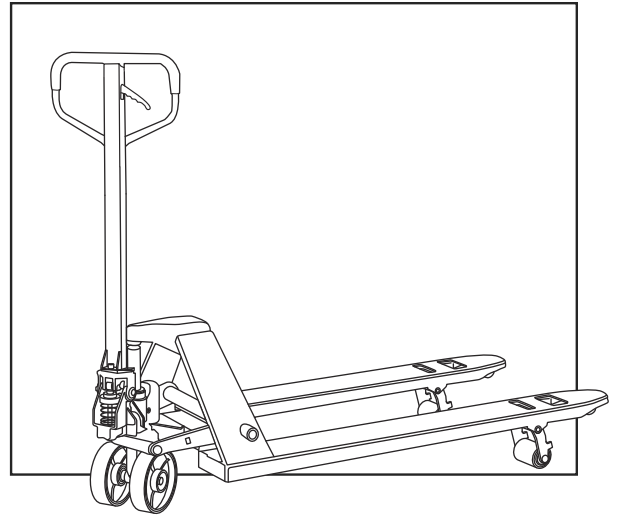
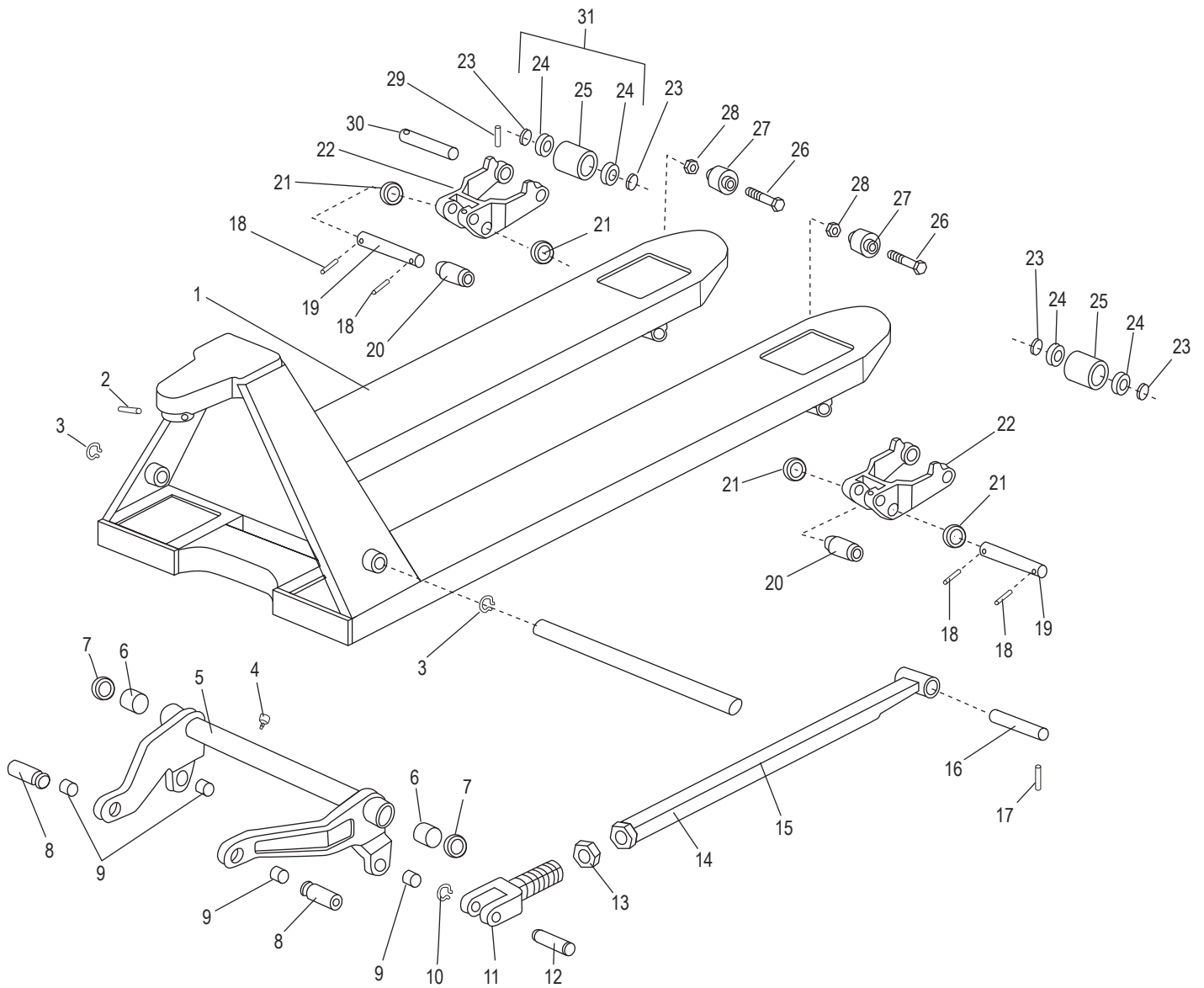
#	DESCRIPTION	QTÉ	RÉF. ULINE	RÉF. DU FABRICANT
1	Cadre de fourche	1	-----	201-RAL5015
2	Boulon	1	H-3045-202G	202G
3	Bague de retenue	2	H-2900-213	213
4	Godet graisseur	1	H-2186-237	237
5	Bras de bascule	1	H-4121-RKARM	203
6	Bague	2	H-2185-206S	204
7	Rondelle	2	H-2185-236S	236
8	Arbre	2	H-2708-205	205
9	Bague	4	H-2708-AC206	206
10	Bague de retenue	2	H-2708-AC208	208
11	Joint	2	H-2708-AC209	AC-209
12	Goupille	2	H-2708-PIN	210
13	Écrou	2	H-2708-AC211	AC-211
14	Tige de poussée	2	H-2708-21248	AC-212-48"FORK
15	Arbre	1	H-2708-214	214
16	Arbre	2	H-2900-216	216
17	Goupille élastique	2	H-2900-219	219
18	Goupille élastique	4	H-2186-220ZS	220ZS
19	Arbre	2	H-2900-19	221
20	Rouleau d'allongement	2	H-2186-218	218
21	Rouleau intermédiaire	4	H-2186-217ZS	217ZS
22	Armature de roue (porteuse) de fourche	2	H-2900-222	222
23	Rondelle	4	H-2708-AC225	AC-225
24	Palier	4	H-2708-AC226	AC-226
25	Roue (porteuse) de fourche	2	H-2708-AC234	AC-234#POLY
26	Boulon	2	H-2708-AC231	AC-231
27	Roue (rouleau) d'entrée	2	H-2708-AC232	AC-232
28	Écrou de blocage	2	H-2708-AC233	AC-233
29	Cheville ressort	2	H-2708-AC230	AC-230
30	Arbre de roue (porteuse) de fourche	2	H-2708-AC235	AC-235#
31	Ensemble pour roue (porteuse) de fourche Comprend : • Roue (porteuse) de fourche (1) • Palier (2)	2	H-5599	226 234#POLY

TRANSPALETTE À LEVAGE RAPIDE

SCHÉMA DE LA POIGNÉE

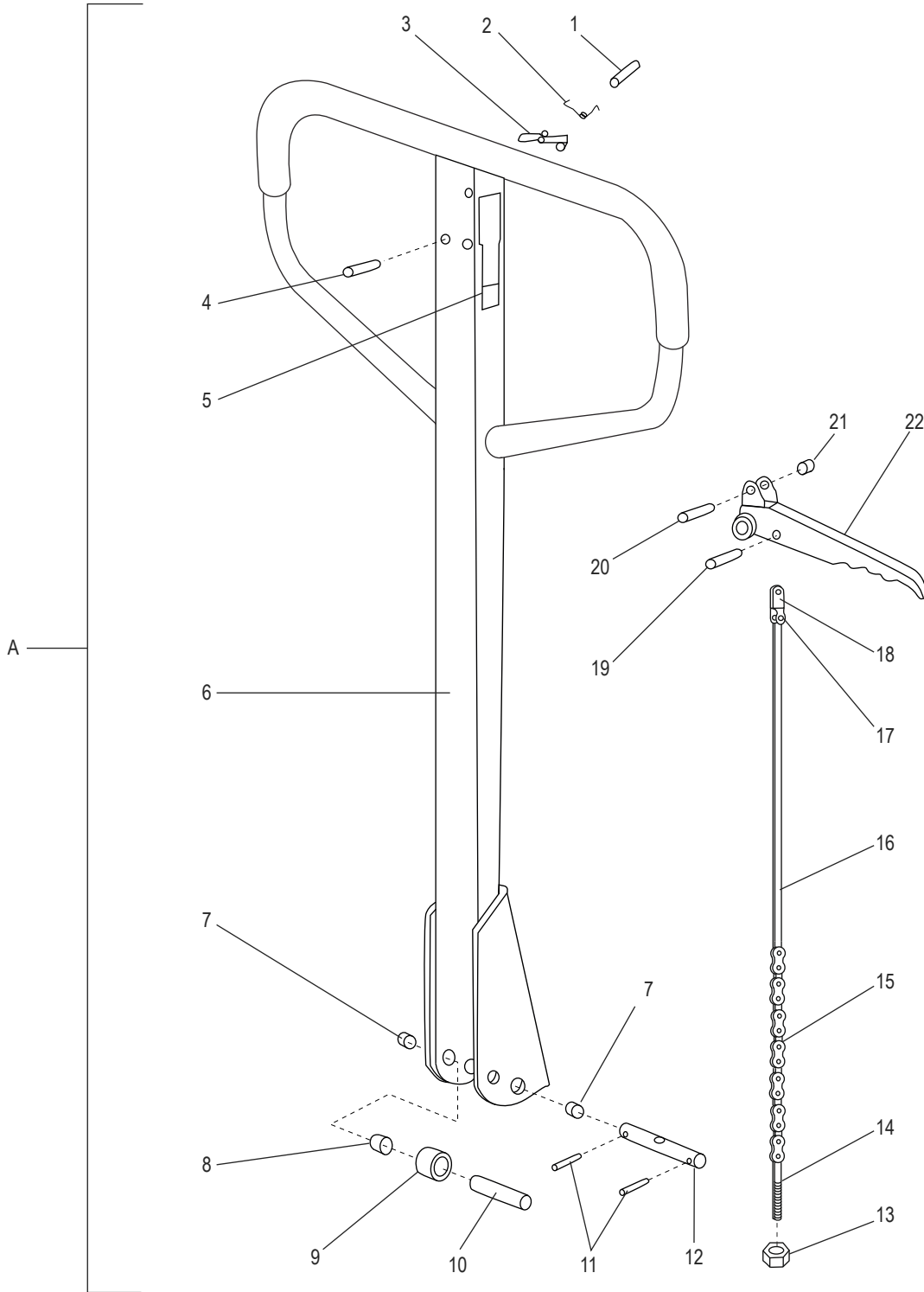

**TRANSPALETTE
À LEVAGE RAPIDE**

LISTE DES PIÈCES DU SCHÉMA DE LA POIGNÉE

#	DESCRIPTION	QTÉ	RÉF. ULINE	RÉF. DU FABRICANT
A	Ensemble de la poignée	1	H-3811	ACQL330HANDLEA
1	Goupille élastique	1	H-29000-115	115
2	Ressort	1	H-3763-114	114
3	Ressort à lame	1	H-2900-113	113
4	Goupille élastique	1	H-2708-112	112
5	Arrêt en caoutchouc	1	H-2186-111	111
6	Barre de levage	1	H-2708-110	110
7	Bague	2	H-2708-AC107	AC-107
8	Bague	1	H-2708-109A	AC-109A
9	Rouleau de pression	1	H-2708-AC109	AC-109
10	Goupille de rouleau	1	H-2708-AC108	AC-108
11	Goupille élastique	2	H-2708-AC106	AC-106
12	Essieu avec trou	1	H-2708-AC105	AC-105
13	Écrou de réglage	1	H-2708-104	104
14	Boulon de réglage	1	H-2708-103	103
15	Chaîne	1	H-2708-102	102
16	Tringle de déclenchement	1	H-2708-AC101	101
17	Goupille	1	H-2708-AC122	122
18	Barre de traction	1	H-2708-AC121	121
19	Goupille élastique	1	H-2708-AC116	116
20	Goupille élastique	1	H-2708-AC119	119
21	Rouleau	1	H-2708-AC118	118
22	Poignée de commande	1	H-2708-AC117	117

**TRANSPALETTE
À LEVAGE RAPIDE**

SCHEMA DE LA POMPE

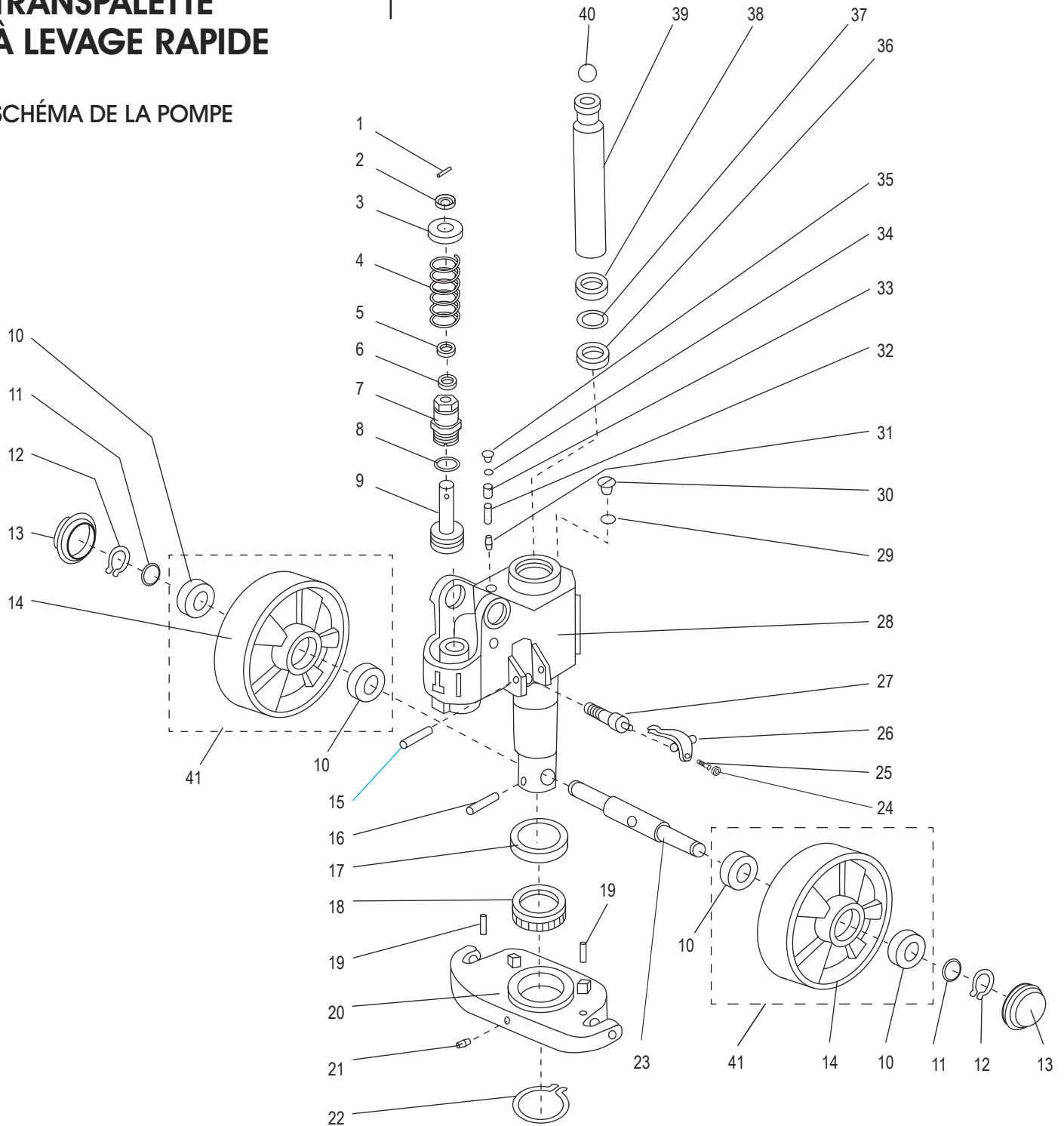

Liste des pièces du schéma de la pompe

#	DESCRIPTION	QTÉ	RÉF. ULINE	RÉF. DU FABRICANT
B	Ensemble de la pompe (non illustré)	1	H-3812	ACQL330PUMPASB
1	Goupille	1	H-5237	335F
2	Capuchon de goupille	1	H-6083	336F
3	Coiffe de ressort	1	H-3763-301F	301F

**TRANSPALETTE
À LEVAGE RAPIDE**

LISTE DES PIÈCES DU SCHÉMA DE LA POMPE SUITE

#	DESCRIPTION	QTÉ	RÉF. ULINE	RÉF. DU FABRICANT
4	Ressort	1	H-3763-302F	302F
5	Anneau de glissement	1	H-2185-DR	304
6	Bague d'étanchéité	1	H-3763-305	305
7	Cylindre de pompe	1	H-3763-338F	338F
8	Joint torique	1	H-3762-337F	337F
9	Piston de pompe pour levage rapide	1	H-3763-303F	303F
10	Palier	4	H-2708-AC309	AC-309
11	Rondelle	2	H-2708-AC308	AC-308
12	Rondelle à ressort	2	H-2708-AC307	AC-307
13	Couvercle antipoussière	2	H-2708-AC306	AC-306
14	Grande roue (directrice)	2	H-2708-AC310	AC-310POLY
15	Goupille élastique	1	H-2900-320	320
16	Goupille élastique	1	H-2900-311	311
17	Couvercle de palier	1	H-2186-337	337
18	Palier	1	H-2186-315	315
19	Goupille élastique	2	H-2900-312	312
20	Plaque de poussée	1	H-2186-313	313
21	Godet graisseur	1	H-2900-335	335
22	Bague de retenue	1	H-2186-314	314
23	Arbre de grande roue (directrice)	1	H-2708-AC316	316
24	Écrou	1	H-2708-317	317
25	Vis	1	H-2708-318	318
26	Plaque de levier	1	H-3763-319	319
27	Cartouche de soupape	1	H-2708-AC321	321
28	Pompe pour levage rapide	1	H-3763-322F	322F
29	Rondelle d'étanchéité	1	H-2900-323	323
30	Vis d'obturation	1	H-2900-324	324
31	Arbre de soupape de sécurité	1	H-2900-334	334
32	Ressort	1	H-2900-333	333
33	Boulon	1	H-2900-332	332
34	Joint torique	1	H-2900-331	331
35	Vis d'obturation	1	H-2900-330	330
36	Bague d'étanchéité	1	H-3762-36	325
37	Joint torique	1	H-3762-37	326
38	Anneau de glissement	1	H-3762-38	327
39	Tige de piston	1	H-2900-328	328
40	Bille d'acier	1	H-2900-329	329
41	Ensemble de roue directrice pour transpalette Comprend : • Palier (2) • Grande roue (directrice) (1)	2	H-5384	-----