

ULINE H-5443 TILTING LIFT TABLE

1-800-295-5510
uline.com

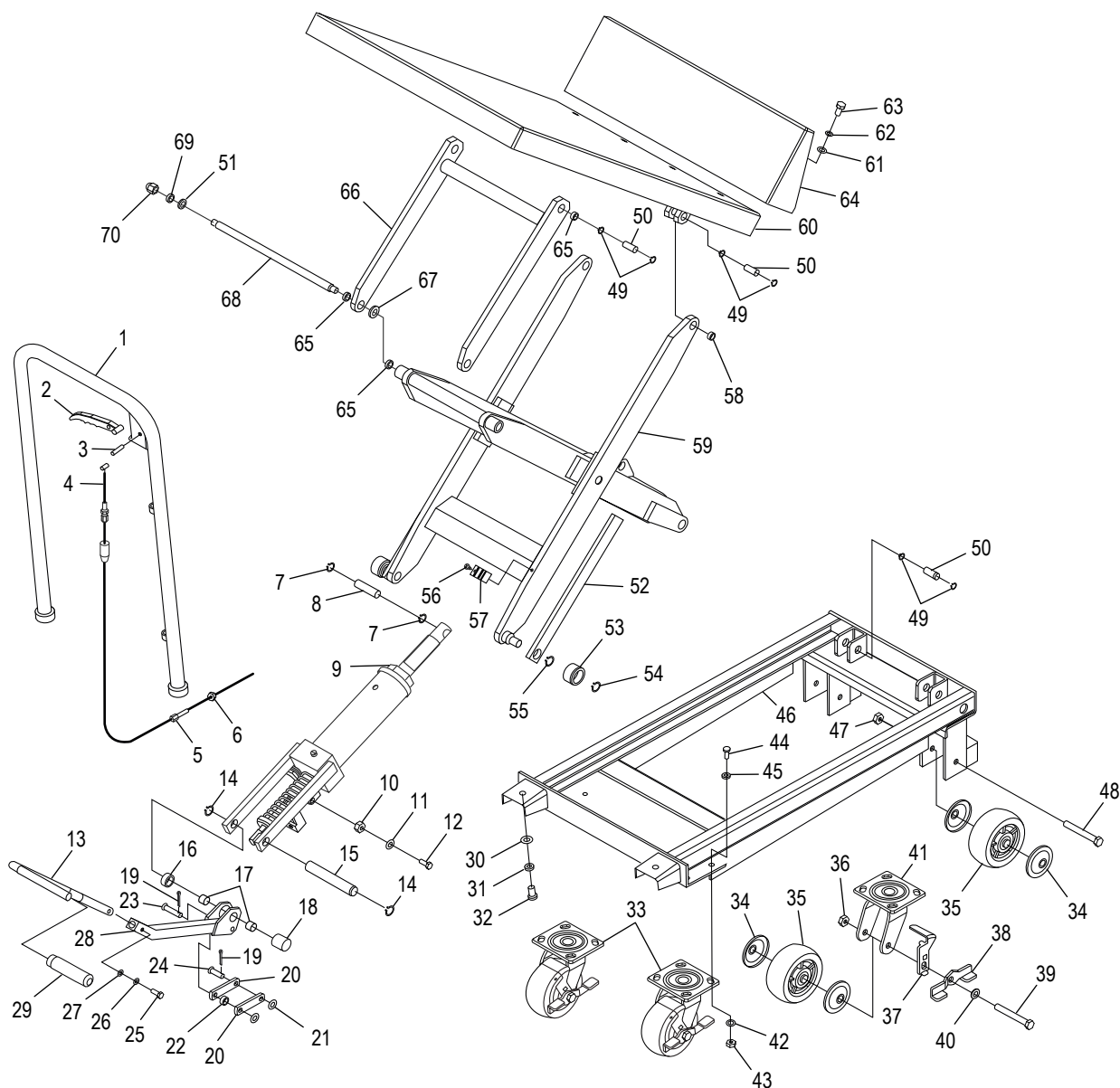
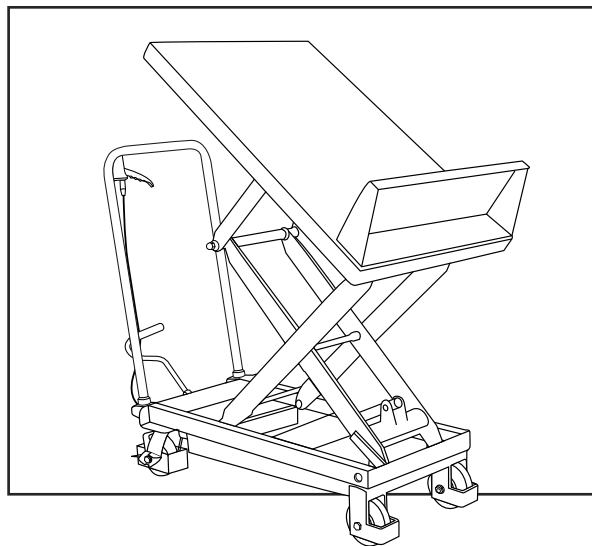

ULINE H-5443
TILTING LIFT TABLE

1-800-295-5510
 uline.com

#	DESCRIPTION	QTY.	ULINE PART NO.	MFG. PART NO.
1	Handle	1	-----	X1
2	Control Bar	1	H-5443-CBARQ	X2
3	Spring Pin	1	-----	X3
4	Soft Wire Shaft	1	-----	X4
5	Adjusting Screw	1	-----	X5
6	Nut	1	-----	X6
7	Circlip for Shaft	2	-----	X7
8	Pin Shaft	1	-----	X8
9	Pump	1	H-5443-9	X9
10	Nut	1	-----	X10
11	Washer	1	-----	X11
12	Clamping Screw	1	-----	X12
13	Foot Lever	1	-----	X13
14	Circlip for Shaft	2	-----	X14
15	Pin Shaft	1	-----	X15
16	Short Bushing	1	-----	X16
17	Sleeve	2	-----	X17
18	Long Bushing	1	-----	X18
19	Cotter Pin	2	-----	X19
20	Connect Plate	2	-----	X20
21	Washer	2	-----	X21
22	Bushing	1	-----	X22
23	Pin Shaft	1	-----	X23
24	Pin Shaft	1	-----	X24
25	Screw	1	-----	X25
26	Spring Washer	1	-----	X26
27	Flat Washer	1	-----	X27
28	Foot Control Frame	1	-----	X28
29	Rubber Cover	1	-----	X29
30	Flat Washer	2	-----	X30
31	Spring Washer	2	-----	X31
32	Screw	2	-----	X32
33	Caster	2	-----	X33
34	Wheel Cover	8	-----	X34
35	Wheel	4	-----	X35
36	Nut	4	-----	X36
37	Brake Disc	2	-----	X37
38	Brake Foot Plate	2	-----	X38
39	Bolt	2	-----	X39
40	Washer	2	-----	X40

ULINE H-5443
TILTING LIFT TABLE

1-800-295-5510
 uline.com

#	DESCRIPTION	QTY.	ULINE PART NO.	MFG. PART NO.
41	Caster Frame	2	-----	X41
42	Washer	8	-----	X42
43	Nut	8	-----	X43
44	Screw	8	-----	X44
45	Washer	8	-----	X45
46	Frame	1	-----	X46
47	Nut	2	-----	X47
48	Bolt	2	-----	X48
49	Circlip for Shaft	12	-----	X49
50	Pin Shaft	6	-----	X50
51	Spacer	2	-----	X51
52	Blocking Rod	2	-----	X52
53	Roller	2	-----	X53
54	Circlip for Shaft	2	-----	X54
55	Circlip for Shaft	2	-----	X55
56	Screw	2	-----	X56
57	Lock Catch	2	-----	X57
58	Sleeve	2	-----	X58
59	Scissor Part	1	-----	X59
60	Table	1	-----	X60
61	Washer	4	-----	X61
62	Spring Washer	4	-----	X62
63	Bolt	4	-----	X63
64	Back	1	-----	X64
65	Sleeve	2	-----	X65
66	Upper Wishbone	1	-----	X66
67	Spacer	2	-----	X67
68	Shaft	1	-----	X68
69	Spring Washer	2	-----	X69
70	Nut	2	-----	X70

ULINE H-5443
**MESA DE ELEVACIÓN
INCLINABLE**

800-295-5510
uline.mx

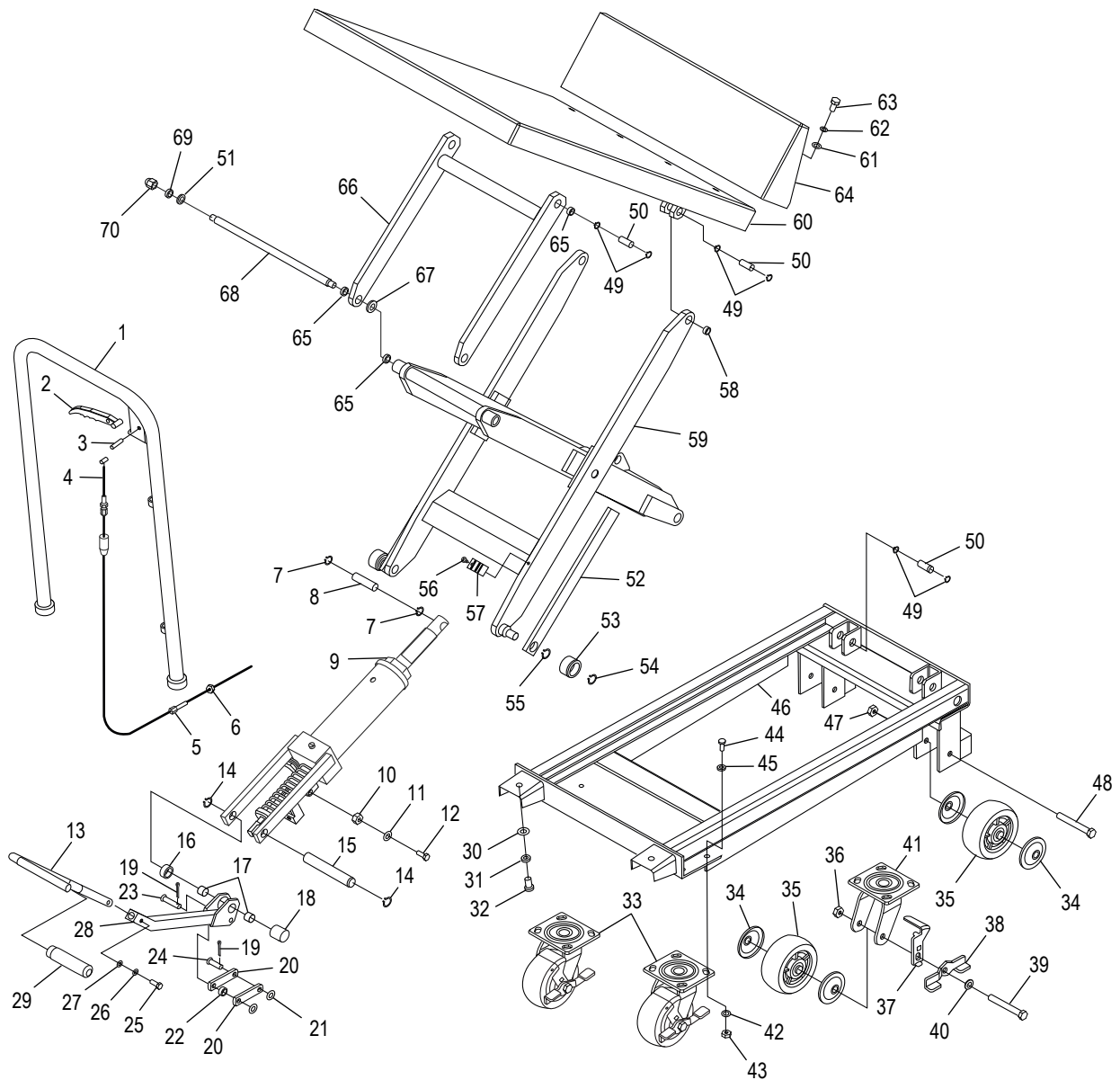
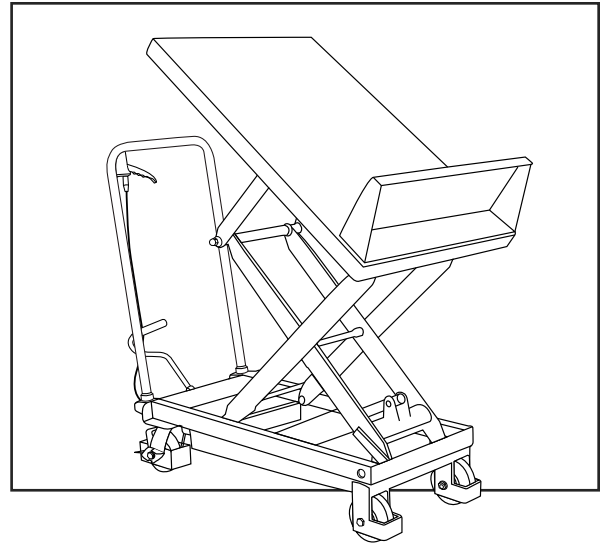

#	DESCRIPCIÓN	CANT.	NO. DE PARTE ULINE	NO. DE PARTE DEL FABRICANTE
1	Asa	1	-----	X1
2	Barra de Control	1	H-5443-CBARQ	X2
3	Perno de Resorte	1	-----	X3
4	Eje de Alambre Suave	1	-----	X4
5	Tornillo de Ajuste	1	-----	X5
6	Tuerca	1	-----	X6
7	Anillo de Retención para Eje	2	-----	X7
8	Eje de Pasador	1	-----	X8
9	Bomba	1	H-5443-9	X9
10	Tuerca	1	-----	X10
11	Rondana	1	-----	X11
12	Tornillo Abrazadera	1	-----	X12
13	Palanca de Pie	1	-----	X13
14	Anillo de Retención para Eje	2	-----	X14
15	Eje de Pasador	1	-----	X15
16	Casquillo Corto	1	-----	X16
17	Manga	2	-----	X17
18	Casquillo Largo	1	-----	X18
19	Pasador de Chaveta	2	-----	X19
20	Placa de Conexión	2	-----	X20
21	Rondana	2	-----	X21
22	Casquillo	1	-----	X22
23	Eje de Pasador	1	-----	X23
24	Eje de Pasador	1	-----	X24
25	Tornillo	1	-----	X25
26	Rondana con Resorte	1	-----	X26
27	Rondana Plana	1	-----	X27
28	Armazón del Control de Pie	1	-----	X28
29	Cubierta de Caucho	1	-----	X29
30	Rondana Plana	2	-----	X30
31	Rondana con Resorte	2	-----	X31
32	Tornillo	2	-----	X32
33	Rueda	2	-----	X33
34	Cubierta para Llanta	8	-----	X34
35	Llanta	4	-----	X35
36	Tuerca	4	-----	X36
37	Disco de Freno	2	-----	X37
38	Placa de Freno para Pata	2	-----	X38
39	Perno	2	-----	X39
40	Rondana	2	-----	X40

#	DESCRIPCIÓN	CANT.	NO. DE PARTE ULINE	NO. DE PARTE DEL FABRICANTE
41	Armazón para Rueda	2	-----	X41
42	Rondana	8	-----	X42
43	Tuerca	8	-----	X43
44	Tornillo	8	-----	X44
45	Rondana	8	-----	X45
46	Marco	1	-----	X46
47	Tuerca	2	-----	X47
48	Perno	2	-----	X48
49	Anillo de Retención para Eje	12	-----	X49
50	Eje de Pasador	6	-----	X50
51	Separador	2	-----	X51
52	Barra de Bloqueo	2	-----	X52
53	Rodillo	2	-----	X53
54	Anillo de Retención para Eje	2	-----	X54
55	Anillo de Retención para Eje	2	-----	X55
56	Tornillo	2	-----	X56
57	Gatillo de Cierre	2	-----	X57
58	Manga	2	-----	X58
59	Parte de Tijera	1	-----	X59
60	Mesa	1	-----	X60
61	Rondana	4	-----	X61
62	Rondana con Resorte	4	-----	X62
63	Perno	4	-----	X63
64	Respaldo	1	-----	X64
65	Manga	2	-----	X65
66	Horquilla Superior	1	-----	X66
67	Separador	2	-----	X67
68	Eje	1	-----	X68
69	Rondana con Resorte	2	-----	X69
70	Tuerca	2	-----	X70

ULINE H-5443
TABLE ÉLEVATRICE
INCLINABLE

1-800-295-5510
uline.ca

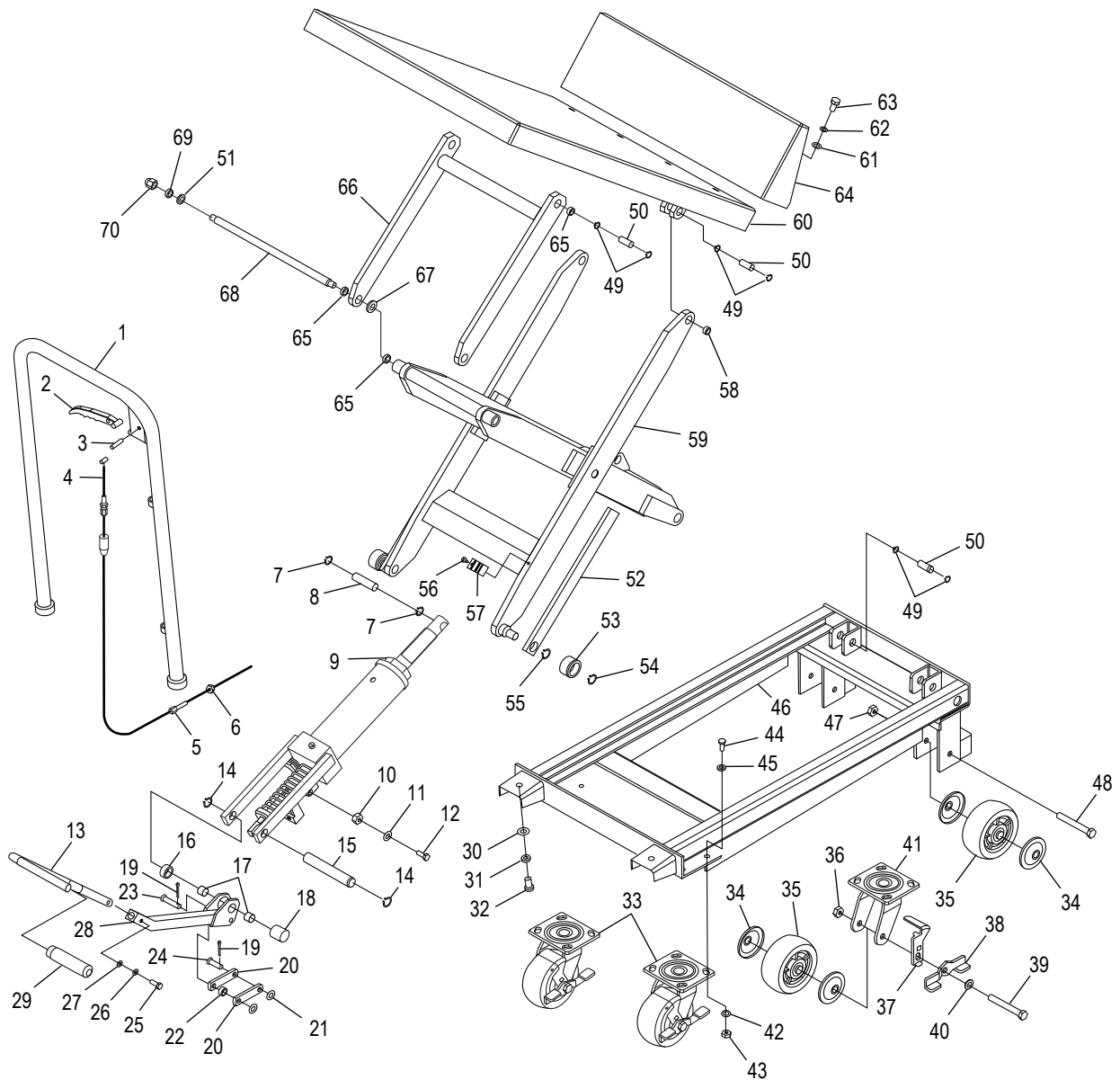
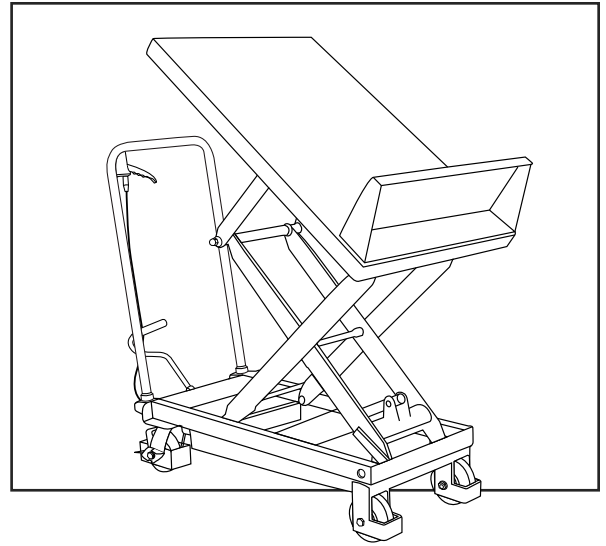

ULINE H-5443
TABLE ÉLÉVATRICE
INCLINABLE

1-800-295-5510
 uline.ca

#	DESCRIPTION	QTÉ	RÉF. ULINE	RÉF. DU FABRICANT
1	Poignée	1	-----	X1
2	Levier de commande	1	H-5443-CBARQ	X2
3	Goupille	1	-----	X3
4	Tige métallique souple	1	-----	X4
5	Vis de réglage	1	-----	X5
6	Écrou	1	-----	X6
7	Anneau de retenue pour tige	2	-----	X7
8	Goupille	1	-----	X8
9	Pompe	1	H-5443-9	X9
10	Écrou	1	-----	X10
11	Rondelle	1	-----	X11
12	Vis de serrage	1	-----	X12
13	Pédale	1	-----	X13
14	Anneau de retenue pour tige	2	-----	X14
15	Goupille	1	-----	X15
16	Petite bague	1	-----	X16
17	Manche	2	-----	X17
18	Longue bague	1	-----	X18
19	Goupille fendue	2	-----	X19
20	Connect Plate	2	-----	X20
21	Rondelle	2	-----	X21
22	Bague	1	-----	X22
23	Goupille	1	-----	X23
24	Goupille	1	-----	X24
25	Vis	1	-----	X25
26	Rondelle de ressort	1	-----	X26
27	Rondelle plate	1	-----	X27
28	Cadre de commande au pied	1	-----	X28
29	Couvercle de caoutchouc	1	-----	X29
30	Rondelle plate	2	-----	X30
31	Rondelle de ressort	2	-----	X31
32	Vis	2	-----	X32
33	Roulette	2	-----	X33
34	Enjoliveur	8	-----	X34
35	Roue	4	-----	X35
36	Écrou	4	-----	X36
37	Disque de frein	2	-----	X37
38	Plaque de frein à pied	2	-----	X38
39	Boulon	2	-----	X39
40	Rondelle	2	-----	X40

ULINE H-5443
TABLE ÉLÉVATRICE
INCLINABLE

1-800-295-5510
 uline.ca

#	DESCRIPTION	QTÉ	RÉF. ULINE	RÉF. DU FABRICANT
41	Cadre de roulette	2	-----	X41
42	Rondelle	8	-----	X42
43	Écrou	8	-----	X43
44	Vis	8	-----	X44
45	Rondelle	8	-----	X45
46	Cadre	1	-----	X46
47	Écrou	2	-----	X47
48	Boulon	2	-----	X48
49	Anneau de retenue pour tige	12	-----	X49
50	Goupille	6	-----	X50
51	Entretoise	2	-----	X51
52	Tige de blocage	2	-----	X52
53	Rouleau	2	-----	X53
54	Anneau de retenue pour tige	2	-----	X54
55	Anneau de retenue pour tige	2	-----	X55
56	Vis	2	-----	X56
57	Loquet de verrouillage	2	-----	X57
58	Manche	2	-----	X58
59	Ciseaux	1	-----	X59
60	Table	1	-----	X60
61	Rondelle	4	-----	X61
62	Rondelle de ressort	4	-----	X62
63	Boulon	4	-----	X63
64	Panneau arrière	1	-----	X64
65	Manche	2	-----	X65
66	Bras triangulaire supérieur	1	-----	X66
67	Entretoise	2	-----	X67
68	Arbre	1	-----	X68
69	Rondelle de ressort	2	-----	X69
70	Écrou	2	-----	X70