

ULINE H-6843

DELUXE WORKSTATION – 48 x 30"

1-800-295-5510
 uline.com

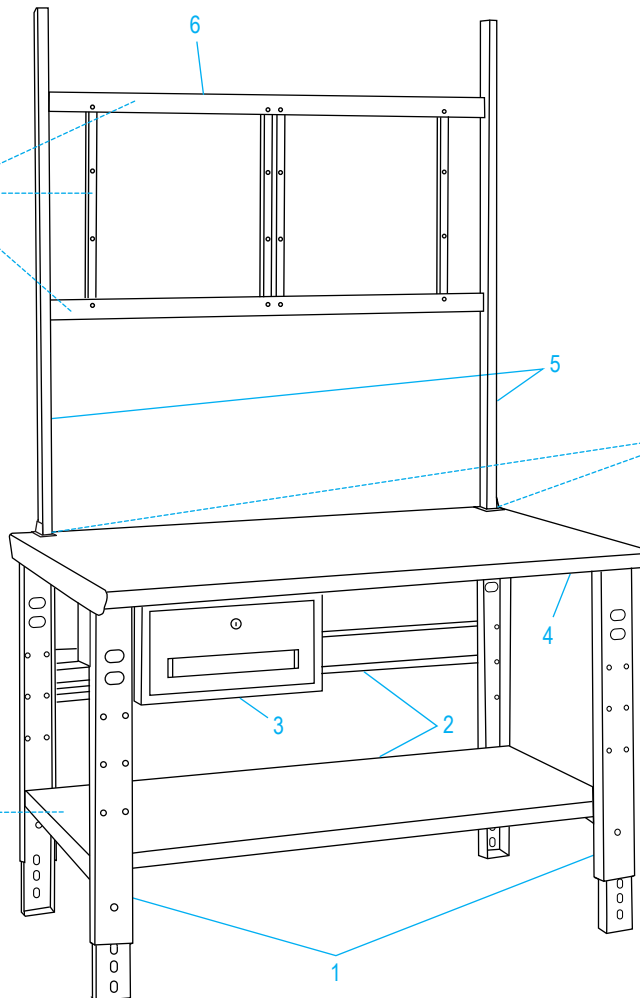
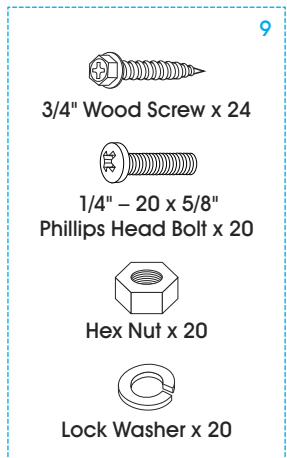
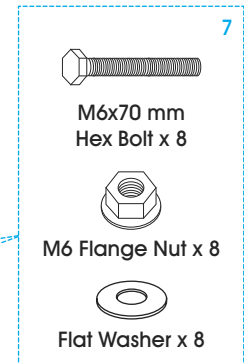
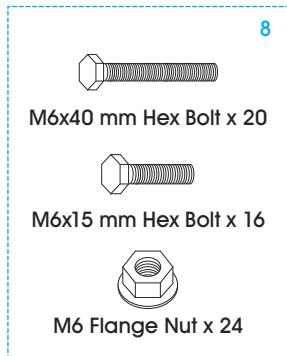
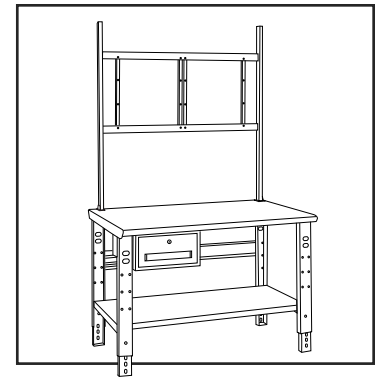

INCLUDED WITH STARTER TABLE

#	DESCRIPTION	QTY.	ULINE PART NO.	MFG. PART NO.
1	Packing Table Legs	2	H-1128LEG	AL-3230-2
2	Full Shelf and Stringer	1	H-6845	FS-3048/WBS-48
3	Packing Table Drawer	1	H-1550	WBD-1L
4	Wood Packing Table Top	1	H-1128-TOP	-----
4	Laminate Packing Table Top	1	H-1128-LTOP	-----
4	Maple Packing Table Top	1	H-1128-MTOP	-----
5	Upright	2	H-5777	H-5777
6	Panel Mounting Kit	1	H-6850	H-6850

REPLACEMENT HARDWARE

#	DESCRIPTION	QTY.	ULINE PART NO.	MFG. PART NO.
7	Hardware Kit – Upright	1	H-5778	H-5778
8	Hardware Kit – Panel Mounting	1	H-5776	H-5776
9	Hardware Kit – Table	1	H-1222-HRDWR	HWULWB96

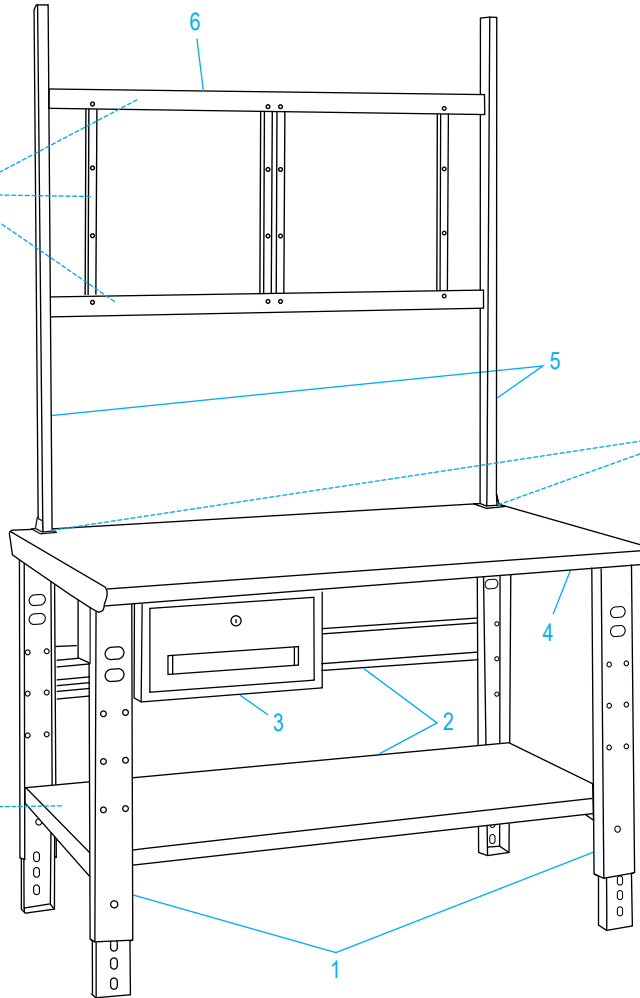
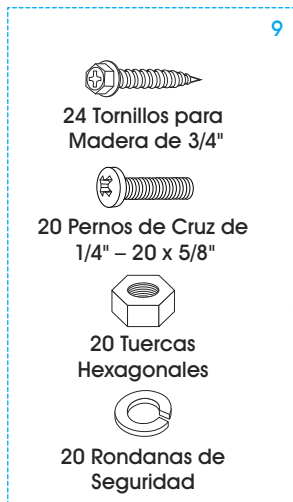
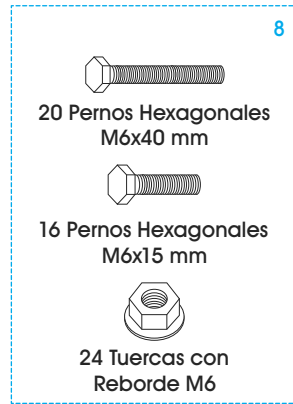
ULINE H-6843**ESTACIÓN DE TRABAJO
DE ALTA CALIDAD –
48 x 30"**800-295-5510
uline.mx**SE INCLUYEN CON LA MESA BÁSICA**

#	DESCRIPCIÓN	CANT.	NO. DE PARTE DE ULINE	NO. DE PARTE DEL FABRICANTE
1	Patas de la Mesa de Trabajo	2	H-1128LEG	AL-3230-2
2	Repisa Completa y Larguero	1	H-6845	FS-3048/WBS-48
3	Cajón de la Mesa de Trabajo	1	H-1550	WBD-1L
4	Cubierta de Madera	1	H-1128-TOP	-----
4	Cubierta de Plástico Laminado	1	H-1128-LTOP	-----
4	Cubierta de Arce	1	H-1128-MTOP	-----
5	Poste	2	H-5777	H-5777
6	Kit de Instalación del Panel	1	H-6850	H-6850

TORNILLERÍA DE REPUESTO

#	DESCRIPCIÓN	CANT.	NO. DE PARTE DE ULINE	NO. DE PARTE DEL FABRICANTE
7	Kit de Tornillería – Vertical	1	H-5778	H-5778
8	Kit de Tornillería – Instalación del Panel	1	H-5776	H-5776
9	Kit de Tornillería – Mesa	1	H-1222-HRDWR	HWULWB96

ULINE H-6843

POSTE DE TRAVAIL DE LUXE – 48 x 30 PO

1-800-295-5510
uline.ca

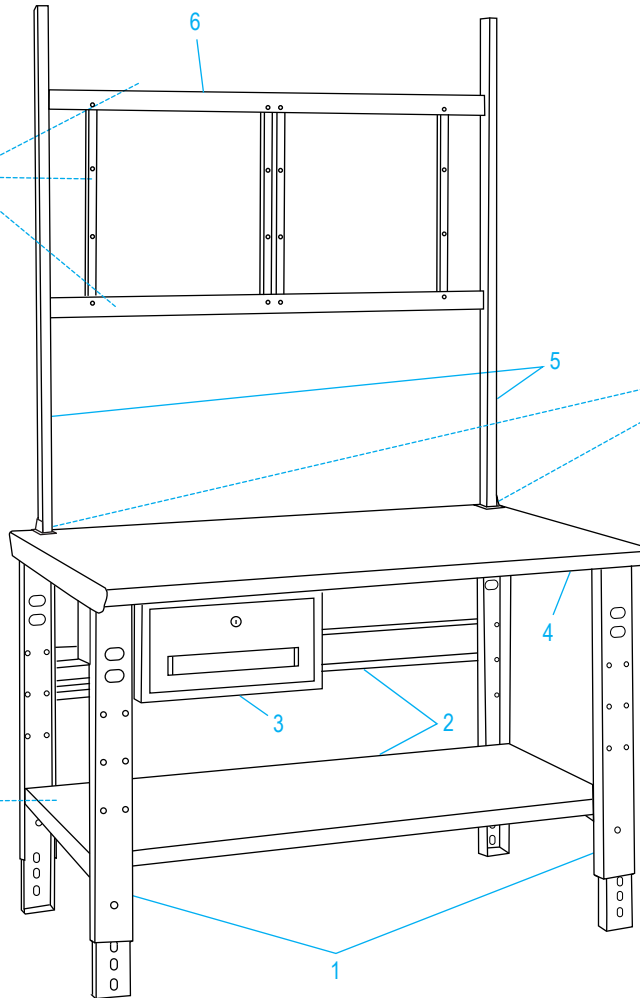
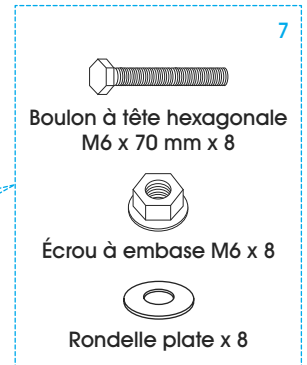
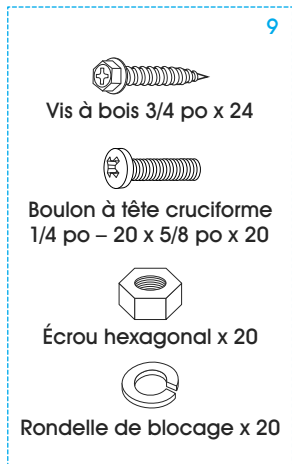
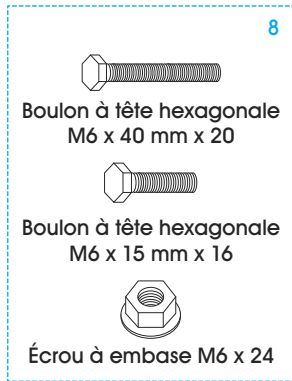

INCLUS AVEC LA TABLE DE BASE

#	DESCRIPTION	QTÉ	RÉF. ULINE	RÉF. DU FABRICANT
1	Pieds de table d'emballage	2	H-1128LEG	AL-3230-2
2	Tablette intégrale et longeron	1	H-6845	FS-3048/WBS-48
3	Tiroir de table d'emballage	1	H-1550	WBD-1L
4	Surface en bois pour table d'emballage	1	H-1128-TOP	-----
4	Surface stratifiée pour table d'emballage	1	H-1128-LTOP	-----
4	Surface en érable pour table d'emballage	1	H-1128-MTOP	-----
5	Montant	2	H-5777	H-5777
6	Matériel d'installation pour panneau	1	H-6850	H-6850

MATÉRIEL DE RECHANGE

#	DESCRIPTION	QTÉ	RÉF. ULINE	RÉF. DU FABRICANT
7	Ensemble de matériel : Montant	1	H-5778	H-5778
8	Ensemble de matériel : Installation pour panneau	1	H-5776	H-5776
9	Ensemble de matériel : Table	1	H-1222-HRDWR	HWLWB96