

ULINE H-10734 CUTLEREASE UTENSIL DISPENSER

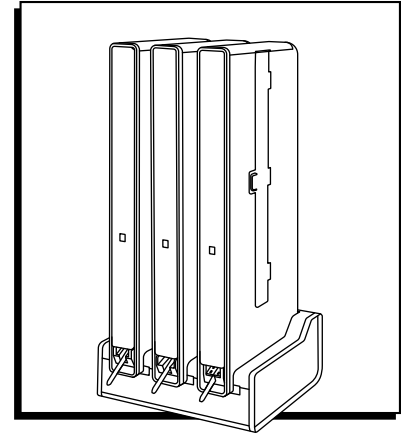

1-800-295-5510
uline.com

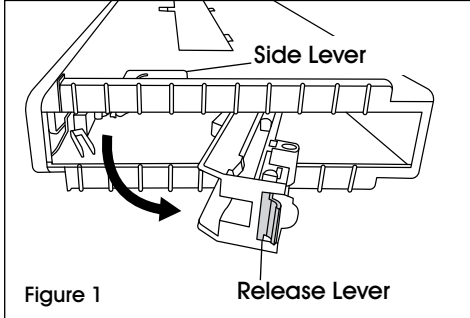



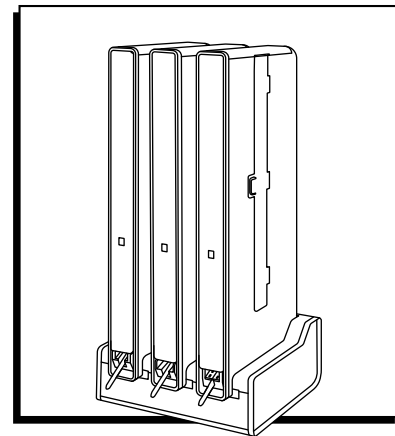

TROUBLESHOOTING

OPERATING ISSUE	CAUSES	RECOMMENDATIONS
<p>The unit is jammed and won't dispense utensils.</p> <p>The primer lever is stuck or appears to be missing.</p>	<p>The unit was loaded incorrectly.</p> <p>The dispenser was primed more than once.</p> <p>The dispenser or tower was turned horizontally.</p> <p>The slide track is not snapped into position.</p> <p>Primer lever was moved forward out of position during shipping.</p>	<ol style="list-style-type: none">Slide tower fully out of base. NOTE: DO NOT place tower on its side or tip upside down.Push release lever to open cutlery slide track on underside of tower. (See Figure 1) <p>Figure 1</p>Clear any cutlery inside.Snap slide track back into position until an audible click is heard. NOTE: Dispenser will not work if not clicked into position.Prime the dispenser by pulling the side lever forward only once.Load tower back onto its base.

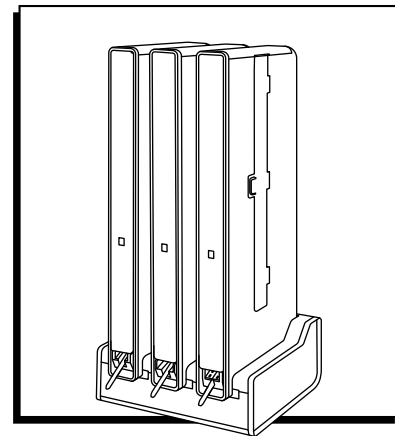
**SOLUCIÓN DE PROBLEMAS**

PROBLEMA DE FUNCIONAMIENTO	CAUSAS	RECOMENDACIONES
<p>La unidad se atascó y no despacha cubiertos.</p> <p>La palanca principal se atoró o parece que falta.</p>	<p>La unidad se cargó de forma incorrecta.</p> <p>El despachador se cargó más de una vez.</p> <p>El despachador o torre se colocó horizontalmente.</p> <p>El riel deslizante no se encajó en su lugar.</p> <p>La palanca principal se movió de lugar durante el envío.</p>	<ol style="list-style-type: none"> 1. Saque completamente la torre de la base. <p> NOTA: NO coloque la torre de costado o al revés.</p> <ol style="list-style-type: none"> 2. Empuje la palanca de liberación para abrir el riel deslizante para cubiertos en la parte inferior de la torre. (Vea Diagrama 1) <div data-bbox="998 1060 1469 1375" style="border: 1px solid black; padding: 5px;"> <p>Diagrama 1 Palanca de Liberación</p> </div> <ol style="list-style-type: none"> 3. Retire cualquier cubierto que quede adentro. 4. Encaje el riel deslizante en su lugar, deberá escucharse un clic. <p> NOTA: El despachador no funcionará si no hace clic en su lugar.</p> <ol style="list-style-type: none"> 5. Prepare el despachador jalando la palanca lateral hacia adelante una vez. 6. Coloque la torre de nuevo en su base.

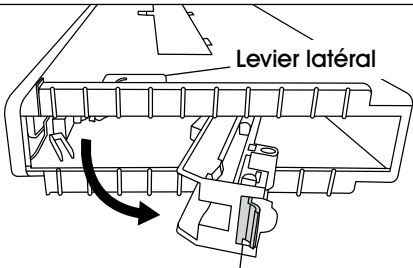
**DÉPANNAGE**

PROBLÈME	CAUSES	RECOMMANDATIONS
<p>Le distributeur est obstrué et ne distribue pas les ustensiles.</p> <p>Le levier d'amorçage est bloqué ou semble absent.</p>	<p>Le distributeur a été mal chargé.</p> <p>Le distributeur a été amorcé plus d'une fois.</p> <p>Le distributeur ou la tour a été placé(e) à l'horizontale.</p> <p>Le rail de coulissement n'est pas enclenché.</p> <p>Le levier d'amorçage a été déplacé vers l'avant pendant l'expédition.</p>	<ol style="list-style-type: none"> Faites glisser la tour complètement hors de la base. <p> REMARQUE : NE placez PAS la tour sur le côté et NE la renversez PAS.</p> <ol style="list-style-type: none"> Poussez le levier de déverrouillage pour ouvrir le rail de coulissement des ustensiles sur la face inférieure de la tour. (Voir Figure 1) <div data-bbox="998 1052 1466 1371" style="border: 1px solid black; padding: 5px;">  <p>Figure 1 Levier de déverrouillage</p> </div> <ol style="list-style-type: none"> Dégagez les ustensiles qui se trouvent à l'intérieur. Remettez le rail de coulissement en place jusqu'à ce qu'un déclic se fasse entendre. <p> REMARQUE : Le distributeur ne fonctionnera pas s'il n'est pas enclenché.</p> <ol style="list-style-type: none"> Amorcez le distributeur en tirant le levier latéral vers l'avant une seule fois. Remplacez la tour sur sa base.